



POLITECNICO DI TORINO  
Repository ISTITUZIONALE

Accurate coaxial standard verification by multiport vector network analyzer

*Original*

Accurate coaxial standard verification by multiport vector network analyzer / A. Ferrero; F. Sanpietro; U.Pisani. - STAMPA. - 3(1994), pp. 1365-1368. ((Intervento presentato al convegno IEEE MTT-S International Microwave Symposium tenutosi a San Diego, CA (USA) nel 23-27 May 1994.

*Availability:*

This version is available at: 11583/2497906 since:

*Publisher:*

IEEE

*Published*

DOI:10.1109/MWSYM.1994.335296

*Terms of use:*

openAccess

This article is made available under terms and conditions as specified in the corresponding bibliographic description in the repository

*Publisher copyright*

(Article begins on next page)

ACCURATE COAXIAL STANDARD VERIFICATION  
BY MULTI-PORT VECTOR NETWORK ANALYZER

Andrea Ferrero, Ferdinando Sanpietro and Umberto Pisani

Dipartimento di Elettronica  
Politecnico di Torino, Torino, Italy

ABSTRACT

We propose a new general formulation for calibrating a Multiport Network Analyzer (NWA), which requires at least only one fully known two port standard and one partially known load (i.e. a sliding load). In principle, since only one fully known two port component is required, the multiport NWA should reach an accuracy higher than an ordinary two-port NWA whose calibration relies on more than one standard. Experimental results confirm the high accuracy of the multiport ( $n \geq 3$ ) NWA, through the verification of commercially available two port standards.

INTRODUCTION

Several authors have already dealt with the problem of multiport ( $n \geq 3$ ) network analyzer calibration by extending usual algorithms, developed for 2-port systems to  $n$ -port test-sets [1, 2, 3]. Recently the authors and others introduced a new solution for a true multiport test set hardware and a calibration technique which uses commercially available one or two port standards [4]. The chosen error model, presented in [4], does not take into account the leakage error but corrects for the switching network error. An iterative procedure for the standard connections was used but the potential redundancy offered by an  $n$ -port system was not considered.

A detailed study of the multiport system redundancy leads to a novel calibration theory which requires only one fully known two port standard and one partially known load to perform the overall  $n$ -port calibration.

The formulation is based on a single general equation which links the standard or the DUT scattering parameters and their corresponding measurements to a suitable set of error coefficients. To solve the calibration problem any combinations of standards can be used so as to give enough linear independent equations ( $4n-1$ ) of the general type introduced here.

This feature allows the user to fit in an optimal way the actual characteristics of the test-set, such as the connector type or the device port geometry.

In particular, the unique fully known *standard* can be a thru, i.e. a simple connection between two test ports, while the partially known one can be a sliding load. Thus no air-line, match or short circuit standard components are required to calibrate the  $n$ -port NWA.

In principle the reduced number of standards should increase the overall accuracy of the multiport test set to respect to 2-port systems. To verify this assumption, the three-port test-set shown in figure 1 was calibrated by this new procedure, and was used to verify high precision coaxial two port standards, since 3-port standards are not commercially available.

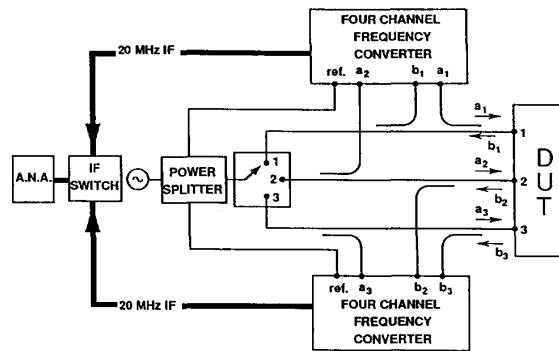

Fig. 1. Block diagram of a three-port S-parameter test-set

CALIBRATION PROCEDURE

As developed in [4], an actual multiport NWA can be seen as an error-free NWA which measures the raw scattering matrix  $S_m$  and a set of  $n$  2-port networks, i.e. the error boxes, which tie the ideal NWA with the DUT as shown in figure 2 [4].

Each error box is defined by a pseudo-scattering matrix  $E_i$ , where  $i = 1, \dots, n$ :

$$E_i = \begin{bmatrix} e_i^{00} & e_i^{01} \\ e_i^{10} & e_i^{11} \end{bmatrix} \quad (1)$$

In a multiport system the error coefficients are collected in four diagonal matrices:

$$\begin{aligned} \bullet \Gamma_{00} &= \text{diag}(e_1^{00}, \dots, e_i^{00}, \dots, e_n^{00}) \\ \bullet \Gamma_{01} &= \text{diag}(e_1^{01}, \dots, e_i^{01}, \dots, e_n^{01}) \\ \bullet \Gamma_{10} &= \text{diag}(e_1^{10}, \dots, e_i^{10}, \dots, e_n^{10}) \\ \bullet \Gamma_{11} &= \text{diag}(e_1^{11}, \dots, e_i^{11}, \dots, e_n^{11}) \end{aligned} \quad (2)$$

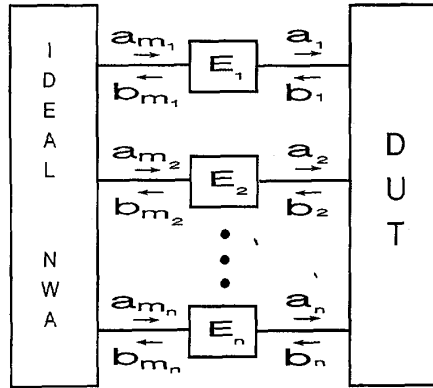

Fig. 2. Generalized model of a multiport test set

After some matrix algebra, which is developed in full detail in [4], one gets:

$$S_m = \Gamma_{00} + \Gamma_{01} [I - S\Gamma_{11}]^{-1} S\Gamma_{10} \quad (3)$$

where  $I$  is the  $n$ -dimensional unit matrix and  $S$  is the scattering matrix of the multiport DUT.

The new development is based on the introduction of the following matrices:

$$\Delta = \Gamma_{00}\Gamma_{11} - \Gamma_{01}\Gamma_{10} \quad (4)$$

and

$$K = e_1^{o1}(\Gamma_{01})^{-1} \quad (5)$$

Further algebraic treatment on equation 3 leads to:

$$K\Gamma_{00} + SK\Gamma_{11}S_m - SK\Delta - KS_m = 0 \quad (6)$$

The de-embedding equation according to this notation becomes:

$$S = K(S_m - \Gamma_{00})(\Gamma_{11}S_m - \Delta)^{-1}K^{-1} \quad (7)$$

The aim of calibration procedures is to compute  $K$ ,  $\Gamma_{00}$ ,  $\Gamma_{11}$  and  $\Delta$  from a proper set of standard measurements.

Equation (6), can be also seen as  $n^2$  scalar equations of the form:

$$\delta_{ij}k_i e_i^{o0} + \sum_{q=1}^n S_{iq}k_q e_q^{o1} S_{mqj} - S_{ij}k_j \Delta_j - k_i S_{mij} = 0 \quad (8)$$

$(i, j = 1, \dots, n)$

where  $\delta_{ij}$  is the Kronecker symbol ( $\delta_{ij} = 1$  if  $i = j$  else  $\delta_{ij} = 0$ ) and  $k_i = K_{ii} = e_1^{o1}/e_i^{o1}$  ( $i = 1, \dots, n$ ). Note that  $k_1 \stackrel{\text{def}}{=} 1$ .

Equation (8) is a general relationship which links error coefficients, standard or DUT  $S_{ij}$  parameters and their corresponding measurements  $S_{mij}$ . This equation can be applied to each standard measurement, apart from the number of ports and their connections.

Since equation 8 is linear in a proper set of error coefficients, the solution of the calibration problem relies on a set of  $4n - 1$  independent equations such as the set (8).

The unknowns can be rearranged in a vector  $u$  as follows:

- $u_i = k_i e_i^{o0}$  ( $i = 1, \dots, n$ )
- $u_i = k_{i-n} e_{i-n}^{o1}$  ( $i = n + 1, \dots, 2n$ )
- $u_i = k_{i-2n} \Delta_{i-2n}$  ( $i = 2n + 1, \dots, 3n$ )
- $u_i = k_{i-3n+1}$  ( $i = 3n + 1, \dots, 4n - 1$ )

A set of  $4n - 1$  linear independent equations is a set of simultaneous equations of the form:

$$Nu = g \quad (9)$$

which defines the whole calibration problem.

Vector  $g$  contains only elements connected to the measurements (i.e.  $S_{mij}$ ) or zeros, while the elements of matrix  $N$  contains also information related the standard  $S_{ij}$  parameters. There are several ways to build matrix  $N$ , once we use all fully known standards.

With fully known standards,  $N$  is fully defined and the solution of (9) is straightforward:

$$u = N^{-1}g \quad (10)$$

This new approach lets the user combining whichever standard connection procedure he prefers in order to match the connector requirements of the DUT.

In three-port case the following simple standard connections provides enough independent equations to calibrate the system:

1. sliding load at port 1
2. thru between port 1 and 2
3. thru between port 1 and 3
4. thru between port 2 and 3

An usual sliding load procedure applied to port 1 gives the directivity term  $E_D$  of the reflectometer at port 1 [5], thus the first equation of the linear system (9) becomes:

$$e_1^{o0} = E_D \quad (11)$$

The thru connections provide 12 equations but only 10 of them are linearly independent as shown from a QR matrix decomposition on the submatrix of  $N$  built from the twelve equations of the thru.

## EXPERIMENTAL RESULTS

Since three port standards are not available, the 3-port test set was verified by an accurate validation of coaxial APC7 one or two port standards.

Since each two port device can be connected in several ways to the multiport NWA every figure reports two traces which identify the whole spread of measurements obtained for the same DUT connected in all the 3 possible ways.

A comparison on a 20cm airline measured by this new technique and by a commercial 2-port NWA calibrated with a TRL algorithm is shown in figure 3. The slightly different plots for  $S_{11}$  could be ascribed to the small differences on the reference impedance of the TRL line versus the sliding load line.

Figure 4 shows the transmission S-parameters of a 30dB standard attenuator measured between port 1 and 3.

## CONCLUSION

A multiport network analyzer was used to verify coaxial standard components. The high accuracy given to the system by this new calibration procedure discloses a new application of multiport system to metrologic, and for high accuracy measurement of multiport devices.

## References

- [1] R.A.Speciale, *A Generalization of the TSD Network Analyzer Calibration Procedure, Covering n-Port Scattering-Parameter Measurements, Affected by Leakage Errors*, IEEE Trans. on Microwave Theory and Techniques, Vol. MTT-25, N.12, Dec. 1977, pp.1100-1115.
- [2] J.C.Tippet, R.A.Speciale, *A Rigorous Technique for Measuring the Scattering Matrix of a Multiport Device with a 2-Port Network Analyzer*, IEEE Trans. on Microwave Theory and Techniques, Vol. MTT-30, N.5, May 1982, pp. 661-665.
- [3] M. Schoon, *A Semi-Automatic 3-port Network Analyzer*, IEEE Trans. on Microwave Theory and Techniques, Vol. MTT-41, N.6/7, June/July 1993, pp. 974-978.
- [4] A. Ferrero, U. Pisani, K. J. Kerwin, *A new implementation of a multiport automatic network analyzer*, IEEE Trans. on Microwave Theory and Techniques, vol. MTT-40, November 1992, pp. 2078-2085
- [5] HP 8510B Reference Manual, Santa Rosa Ca, 1985
- [6] Engen G.F. and Hoer C.A.: *Thru-reflect-line: An Improved Technique for Calibrating the Dual Six-port Automatic Network Analyzer*, IEEE Trans. on Microwave Theory and Techniques, Vol. MTT-27, N.12, Dec. 1979, pp.987-993.

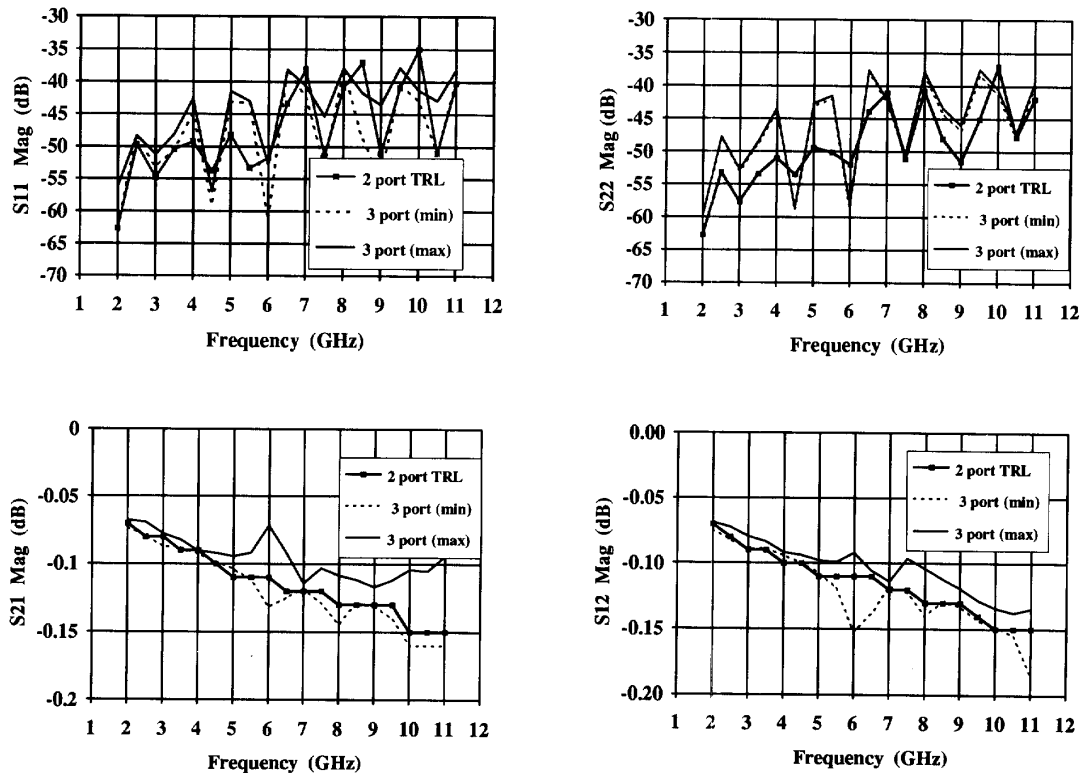

Fig. 3a. 20cm Coaxial Airline S-parameters  
(20.35cm Nominal Electrical Length)

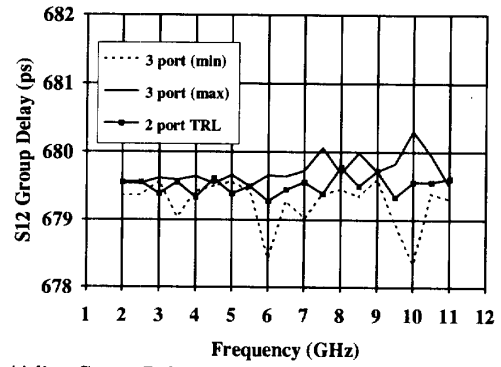
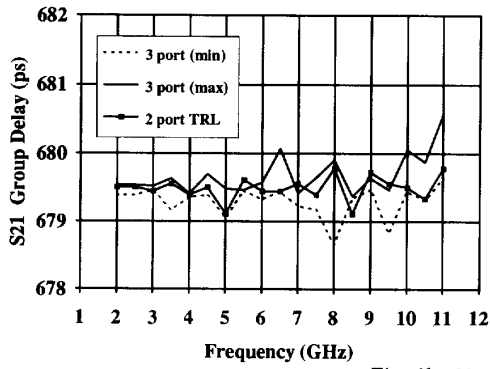

Fig. 3b. 20cm Coaxial Airline Group Delay  
(20.35cm Nominal Electrical Length)

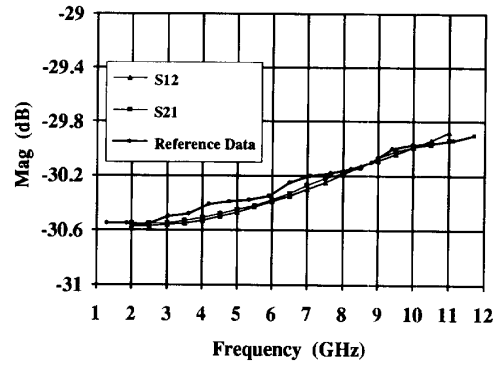

Fig. 4 30dB Attenuator Transmission S-parameters