

Tilting vehicle and control system thereof

Original

Tilting vehicle and control system thereof / Carabelli, S., Macchi, P.. - (2009).

Availability:

This version is available at: 11583/2497244 since:

Publisher:

Published

DOI:

Terms of use:

This article is made available under terms and conditions as specified in the corresponding bibliographic description in the repository

Publisher copyright

(Article begins on next page)



- (51) **International Patent Classification:**
B62K 5/04 (2006.01) *B62K 5/08* (2006.01)
- (21) **International Application Number:**
PCT/IT2009/000520
- (22) **International Filing Date:**
18 November 2009 (18.11.2009)
- (25) **Filing Language:** English
- (26) **Publication Language:** English
- (71) **Applicant (for all designated States except US):** **THREE TILTING WHEELS S.r.L.** [IT/IT]; Via Pier Carlo Boggio, 61, Torino (IT).
- (72) **Inventors; and**
- (75) **Inventors/Applicants (for US only):** **CARABELLI Stefano** [IT/IT]; c/o Three Tilting Wheels S.r.L., Via Pier Carlo Boggio, 61, 10138 Torino (IT). **MACCHI Pietro** [IT/IT]; c/o Three Tilting Wheels S.r.L., Via Pier Carlo Boggio, 61, 10138 Torino (IT).
- (74) **Agent:** **JORIO Paolo**; c/o Studio Torta S.r.L., Via Viotti, 9, 10121 Torino (IT).
- (81) **Designated States (unless otherwise indicated, for every kind of national protection available):** AE, AG, AL, AM, AO, AT, AU, AZ, BA, BB, BG, BH, BR, BW, BY, BZ, CA, CH, CL, CN, CO, CR, CU, CZ, DE, DK, DM, DO, DZ, EC, EE, EG, ES, FI, GB, GD, GE, GH, GM, GT, HN, HR, HU, ID, IL, IN, IS, JP, KE, KG, KM, KN, KP, KR, KZ, LA, LC, LK, LR, LS, LT, LU, LY, MA, MD, ME, MG, MK, MN, MW, MX, MY, MZ, NA, NG, NI, NO, NZ, OM, PE, PG, PH, PL, PT, RO, RS, RU, SC, SD, SE, SG, SK, SL, SM, ST, SV, SY, TJ, TM, TN, TR, TT, TZ, UA, UG, US, UZ, VC, VN, ZA, ZM, ZW.
- (84) **Designated States (unless otherwise indicated, for every kind of regional protection available):** ARIPO (BW, GH, GM, KE, LS, MW, MZ, NA, SD, SL, SZ, TZ, UG, ZM, ZW), Eurasian (AM, AZ, BY, KG, KZ, MD, RU, TJ, TM), European (AT, BE, BG, CH, CY, CZ, DE, DK, EE, ES, FI, FR, GB, GR, HR, HU, IE, IS, IT, LT, LU, LV, MC, MK, MT, NL, NO, PL, PT, RO, SE, SI, SK, SM, TR), OAPI (BF, BJ, CF, CG, CI, CM, GA, GN, GQ, GW, ML, MR, NE, SN, TD, TG).
- Published:**
— with international search report (Art. 21(3))

(54) **Title:** TILTING VEHICLE AND CONTROL SYSTEM THEREOF

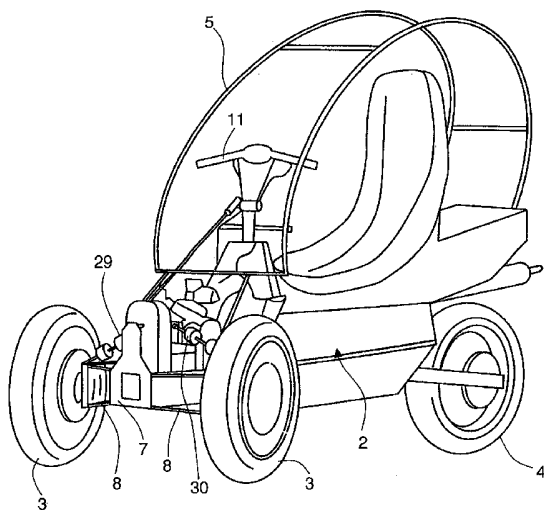

Fig. 1

(57) **Abstract:** A vehicle comprises at least one steering wheel (3),» at least two other wheels (3, 4),- control means (11) suitable for being operated by a driver to steer the steering wheel (3), a frame (2) supported by said wheels (3, 4) and tiltable with respect to the ground when the vehicle steers and first actuating means (23) to control the tilting position of said frame(2). In particular, vehicle (1) comprises a decoupling device (14) to decouple the angular position of control means (11) to the angular position of steering wheel (3) and a control unit (25) configured to activate first actuating means (23) when control means (11) are operated by the driver before said steering wheel (3) substantially changes its angular position at least when said vehicle turns running above a given speed threshold.

TILTING VEHICLE AND CONTROL SYSTEM THEREOF

TECHNICAL FIELD

The present invention relates to a tilting
5 vehicle comprising more than two wheels at least one
of which is a tilting wheel, in particular a three-
wheeled vehicle, and to a control system thereof.

BACKGROUND ART

A tilting vehicle with more than two wheels
10 generally comprises a frame attached to the wheels in
a tilting manner with respect to the ground so that
the frame tilts during steering, actuating means
connected to the frame and a tilting control unit
connected to the actuating means to control the
15 angular position of the frame.

Recently, compact tilting vehicles with more
than two wheels were developed aiming at reducing
pollution and traffic in big cities.

Controlling of the angular position of the frame
20 and of the tilting wheels is an important issue
relating to tilting vehicles.

Tilting vehicles are known where the tilting
control unit uses a lateral acceleration sensing
algorithm. In a lateral acceleration sensing

algorithm (generally known in the scientific literature as "Direct Tilt Control, DTC"), a sensor measures the lateral acceleration of the frame during steering, the control unit elaborates sensor's output and drives the actuators to modify the angular position of the frame such that the weight and the centrifugal force are in rotational equilibrium about the tilting axis.

In this case, actuators are powered after the wheels substantially steer and an inertial load is generated during steering. This has the drawback that actuators requires the power to counterbalance the full steering inertial load. Another drawback is that steering inertial load is positively related to speed and may reach high values. Therefore wheels must have a relatively high lateral distance in order to avoid rollover and ensure stability in any driving condition.

DISCLOSURE OF INVENTION

The scope of the present invention is to provide a tilting vehicle free from the aforementioned drawbacks.

A further scope of the present invention is to provide a control method for a tilting vehicle.

The scope of the present invention is achieved by a vehicle according to claim 1 and a control method according to claim 14.

BRIEF DESCRIPTION OF THE DRAWINGS

5 For a better understanding of the present invention, said vehicle and said method are further described also with reference to the attached figures, wherein:

- Figure 1 is a perspective view of a vehicle
10 according to the present invention with straight steering wheels and non-tilted frame;

- Figure 2 is an enlarged perspective view of a front portion of figure 1;

- Figure 3 is an enlarged longitudinal cross
15 section of a component of the steering unit of the vehicle of figure 1; and

- Figure 4 is a block diagram of a control method implemented to control the vehicle of figure
1.

20 BEST MODE FOR CARRYING OUT THE INVENTION

In Figure 1, designated as a whole by 1 is a tilting vehicle comprising a tilting frame 2, two front wheels 3 and a single rear wheel 4, wheels 3 and 4 being connected to frame 2. Frame 2 is a

completely rigid frame supporting the components of the vehicle, e.g. internal combustion engine, seat of the driver, and can be configured with an upper portion 5 protecting the driver in the frontal, rear and upward direction.

Vehicle 1 further comprises an internal combustion engine driving rear wheel 4 and, preferably, electric motors housed in front wheels 3, i.e. front wheels 3 are electric motor wheels.

10 Front wheels 3 are connected to a front portion 7 of frame 2 by means of suspension wishbone arms 8 hinged to a hub-carrier supporting the rotating hub connected to front wheel 3 and to front portion 7. Wishbone arms 8 are connected to front portion 7 so
15 that front wheels 3 and frame 2 tilt in a coordinated way, in particular by the same angle, when vehicle 1 is bending along a turn. Furthermore, connection of wishbone arms 8 is such that front wheels 3 can move independently from one another to absorb a relief or
20 a depression of a street.

Advantageously, each front wheel 3 is connected to front portion 7 by an upper and a lower wishbone 8 and all wishbones 8 have the same length. Lower and upper wishbone 8 are parallel to one another in any

working condition. For example, wishbones 8, front portion 7 and front wheels 3 are connected as described in patent application EP1798081.

In figure 2 a steering unit 10 of vehicle 1 is shown.

Steering unit 10 comprises a rotatable handlebar 11 directly operated by the driver and a device 12 configured to transmit the angular position of handlebar 11 to front wheels 3. Advantageously, device 12 comprises a rotatable steering column 13 connected to front wheels 3 in a manner that is known in the art and will not be described further, a torsionally resilient joint 14 to couple in a torsionally resilient manner handlebar 11 to wheels 3 and a steering actuator 15 (schematically shown in figure 1) providing the largest amount of torque to steer wheels 3. In particular steering column 13 comprises a first portion 13' connected between handlebar 11 and resilient joint 14, and a second portion 13'' connected between joint 14 and front wheels 3.

According to a preferred embodiment of the present invention, resilient joint 14 is configured to have two stop position so that handlebar 11 and

steering column portion 13'' may relatively rotate within a predefined interval. Once the maximum relative angular position is reached in either rotational directions, handlebar 11 and steering column 13 become connected in a rotationally rigid way so that if handlebar 11 is further rotated by a certain amount, steering column portion 13'' is driven in rotation by the same amount.

For example, resilient joint 14 comprises a torsion bar 16 connected between steering column portions 13' and 13'', a sleeve 17 rigidly connected to steering column portion 13' and two fixed pins 18 radially extending from steering column portion 13'' towards torsion bar 16. Each pin has an end portion engaging a respective circumferential slot 19 (only one slot is illustrated in figure 3) defined by sleeve 17. Furthermore, each slot 19 is circumferentially delimited by two abutments 20.

The angular interval wherein handlebar 11 and steering column portion 13'' can relatively rotate is defined by the circumferential dimension of slot 19. When pins 18 contact either abutment 20, handlebar 11 is rigidly connected to steering column portion 13''.

According to the present invention, resilient

joint 14 also comprises a first and a second angular sensor 21 and 22 to detect the relative angular position of steering column portions 13' and 13''. According to a preferred embodiment, output of sensors 21 and 22 can be combined to the stiffness of torsion bar 16 in order to evaluate the torque that the user applies to handlebar 11. However, unlike standard electric powered servo steering system, in the present invention the measure of steering wheel torque is not directly and immediately transformed into torque at the steerbox that rotates front wheels 3.

Vehicle 1 further comprises a tilting control unit that controls the tilting position of frame 2 with respect to the street surface. Such tilting control unit comprises actuating means 23 holding frame 2 in a preferred tilting position, a plurality of sensors 24 detecting dynamic parameters of vehicle 1 and an electronic control unit 25 elaborating the outputs of sensors 24 and of sensors 21, 22 to control steering actuator 15 and actuating means 21 through a signal S that will be better described later on.

Advantageously, actuating means 21 comprises a

rotating motor 26, in particular an electric motor, a reduction gear 27 connected to the output of motor 26 by a transmission, e.g. a belt transmission, a crank arm 28 connected to a first output shaft of gear 27 and rising transversally, e.g. perpendicularly in a rest position, with respect to wishbone arms 8, and a brake B, e.g. a disk brake, to block motor 26, gear 27 and ram 28 in a preferred position. Disk brake B is controlled by electronic control unit as well.

10 Actuating means 21 and frame 2 are connected as follows.

Front portion 7 of frame 2 has a substantially parallelepiped shape each corner of which is hinged to a respective wishbone 8. Front portion 7 is 15 rigidly connected to the housing of motor 26 and of gear 27.

Crank arm 28 is connected to both right and left upper wishbones 8 by means of a respective shock absorber 29 and 30 set at opposite sides with respect 20 to crank arm 28.

During steering at a cruise speed, e.g. higher than 25km/h, the user rotates handlebar 11 and sensors 21, 22 detect a change in the relative angular position between steering column portions

13', 13''. According to the present invention, torsion bar 16 is designed to have a low stiffness such that a rotation of the handlebar 11 having pin 18 not contacting abutments 20 does not substantially
5 steer front wheels 3 per se, i.e. front wheels 3 substantially steer either because of tilting and/or because of the activation of steering actuator 15 and do not substantially steer when handlebar is rotated and pin 18 is not contacting abutments 20.

10 At least at a high speed, immediately after handlebar 11 is rotated, front wheels 3 do not substantially rotate to follow the road bend according to the input given by handlebar 11 as in standard powered steering systems. On the contrary,
15 electronic control unit 25 activates motor 26 to initiate tilting of frame 2 and front wheels 3 towards the centre of the bend.

After tilting of frame 2, ECU 25 may activate actuator 15 and wheels 3 further steer by the proper
20 angle preferably calculated on the basis of the torque applied by the user to handlebar 11 in order to give to the driver the same feeling as with a torsionally rigid device 12, i.e. torsion bar 16 is a part of a torque sensor.

Therefore, according to the present invention, ECU 25 activates tilting of frame 2 and of wheels 3, 4, when the user rotates handlebar 11. The tilting of front wheels 3 produces per se a turning of vehicle 1. In order to provide the proper turning of vehicle 1 in view of the speed and the radius of curvature of the road bend, ECU 25 may activate steering actuator 15 to further steer front wheels 3. In particular, steering by tilting front wheels 3 together with frame 2 is very efficient when vehicle 1 runs at a high speed, e.g. above 25km/h. More in general, ECU 25 implements a control method by which at low speed, i.e. below 25 km/h, wheels 3 steer because steering actuator 15 is actuated and frame 2 is maintained substantially perpendicular with respect to the ground surface. In such working condition it can be said that torsional stiffness of device 12 between handlebar 11 and front wheel 3 is maximum, ideally infinite, i.e. handlebar 11 and front wheels 3 are torsionally connected in a rigid way. Torsional stiffness between handlebar 11 and front wheels 3 is given by the combined effect of torsion bar 16 and steering actuator 15 and is variable. In particular, when a large torsion angle of handlebar 11 is

detected by ECU 25 and the torsional stiffness of device 12 is set to be low, steering actuator 15 is activated so to give a small steering angle to front wheels 3. On the contrary, when torsional stiffness of device 12 is ideally infinite, ECU 25 activates steering actuator 15 so that handlebar 11 and portion 13'' rotates by the same angle.

Preferably, ECU 25 activates steering actuator 15 depending on the speed of vehicle 1 measured by sensor 24. In particular, torsional stiffness of device 12 decreases when speed of vehicle 1 increases. Decrease of torsional stiffness may follow many different paths, e.g. continuous and monotone paths. When speed of vehicle 1 is low, the turning effect deriving from the tilting of front wheel 3 becomes less and less effective and turning takes place by steering front wheels 3 through steering actuator 15, as previously described.

For example, above the threshold set at 25 km/h, ECU 25 controls both steering actuator 15 and actuating means 23. In particular, stiffness of device 12 decreases so that when the driver turns handlebar 11 actuating means 23 are activated so that frame 2 and front wheels 3 tilt. Optionally, there is

a time delay between activation of steering actuator 15 after the activation of actuating means 23. Such delay increases when the speed increases, till steering 15 is not anymore activated and vehicle 1 steers only by tilting of front wheels 3 and frame 2. Such delay may combine with torsional stiffness change described above in the control method implemented by ECU 25.

When also actuator 15 is activated, ECU 25 continues to control the angular position of frame 2 in order to counterbalance the inertial load due to lateral acceleration of frame 2 itself and minimize the resulting overall force applied to the center of gravity of the frame. In particular, when sensor 24 also comprises a lateral accelerator, ECU 25 is configured to set the lateral acceleration at a level that is perceivable by the driver, so that

When vehicle 1 comes around the road bend, the torque on handlebar 11 reverses and ECU 25 activates actuating means 21 to tilt and 'rise' frame 2. Actuator 15 is activated to steer front wheels 3 only after actuating means 21 is powered.

Figure 4 shows in a greater detail how tilting control unit of vehicle 1, resilient joint 14 and

steering actuator 15 are connected.

Main input to the system are road profile 30 torque 31 on handlebar 11 and external forces acting on the frame, e.g. wind 32.

5 Furthermore, frame 2 is equipped with sensors 24 measuring longitudinal speed, right wishbone angle, left wishbone angle, crank 28 angle, lateral acceleration.

The output of sensors 24 are elaborated by a
10 state observer to obtain the estimated values over time of parameters such as estimated lateral acceleration 34, and estimated roll angle 35. Other parameters are: estimated crank angle 28, estimated right wishbone angle, estimated left wishbone angle,
15 estimated longitudinal speed, estimated steering column portion 13' angle, estimated steering column portion 13'' angle and estimated steering column deformation 36, defined as difference between estimated steering column portion 13', 13'' angles.

20 All the above parameters are then elaborated by a supervisor 37 that is programmed with the control algorithm for frame 2.

In particular, ECU implements a feedback control 38 for tilt torque, a feedforward control 39 for tilt

torque and a reference torque control for steering actuator 15 of front wheels 3.

In greater detail, feedback control 38 has a first input defined by estimated lateral acceleration 5 34 and a second input, defined by desired lateral acceleration 40 set by supervisor 37.

Estimated and lateral acceleration 34, 37 are processed by a subtraction node 41 and the resulting error signal is multiplied by a variable gain 42 10 controlled by supervisor 37.

The resulting gained error signal is processed by prefilter 43 and subtracted to estimated roll angle 35 in node 44. The resulting error signal is an input for an addition node 45.

15 Feedforward control 39 comprises estimated steering column deformation 36 and a gain 46 controlled by supervisor 37. The resulting gained signal is processed in addition node 45 to generate control signal S for actuating means 21.

20 Signal S is also split downstream to node 45 and processed by a variable gain 47 controlled by supervisor 37 to generate signal 48 enabling brake B.

Therefore, control signal S has a mixed structure defined by both a feedforward component and

a feedback component.

As mentioned before, ECU 25 also controls steering actuator 15. In particular, estimated steering column deformation 36 is split before entering in supervisor 37 and processed in a subtraction node 49 with desired steering column deformation 50 set by supervisor 37.

The resulting error signal is processed by a variable gain 51 to obtain control signal 52 for steering actuator 15.

The advantages of vehicle 1 according to the present invention are the following.

Frame 2 and front wheels 3 tilt to provide in combination a turning effect and a decrease in lateral acceleration. In particular, the center of gravity of frame 2 and all of the components attached thereto moves towards the center of curvature of the bend and generate a momentum opposite to that generated by centrifugal inertial force resulting in a reduced overall momentum applied to the frame. Therefore, reaction between the ground and front wheels 3 due to such overall momentum is reduced and either the track of the wheels 3 can be reduced or the maximum speed of the vehicle running the bend can

increase without impacting on stability.

Such principle is applied to a vehicle having three wheels and two front steering wheels and the effect is particularly appreciated in that the lateral dimension of the vehicle may be decreased to achieve a stability that is superior to that of two wheeled vehicles with a minimum increase in lateral dimension, in order to be more agile in traffic compared to four wheeled vehicles. All the above advantages are achievable because handlebar 11 is connected to

Lastly, it is clear that modifications and variations may be made to the vehicle described herein without departing from the scope of protection of the present invention, as defined in the appended claims.

Spring 14 can be totally absent so that front wheels 3 steer by wire.

Alternatively, torsional stiffness control of device 12 can be avoided to simplify ECU 25 and a comparable functioning can be obtained by the sole variation of time delay of actuation of steering actuator 15 after actuating means 23.

CLAIMS

1. Vehicle comprising at least one tiltable steering wheel (3), at least two other wheels (3, 4), control means (11) suitable for being operated by a driver to steer said steering wheel (3), a frame (2) supported by said wheels (3, 4) and tiltable together with said at least one steering wheel (3) with respect to the ground when the vehicle turns and first actuating means (23) to control the tilting position of said frame (2) and of said at least one steering wheel (3), characterized by comprising a decoupling device (14) to decouple said control means (11) from said steering wheel (3), a control unit (25) configured so that said first actuating means (23) tilt said frame (2) and said at least one tiltable steering wheel (3) when said control means (11) are operated by the driver, second actuating means (15) connected to said control unit (25) to control the steering angle of said steering wheel (3) and a speed sensor (24) connected to said control unit (25) to measure the speed of the vehicle, and in that said control unit (25) is configured to activate said second actuating means (15) depending on the speed measured by said speed sensor (24).

2. Vehicle according to claim 1, characterized in that said decoupling device (14) has a variable torsional stiffness controlled by said control unit (25).

5 3. Vehicle according to claim 2, characterized in that said control unit (25) is configured to decrease the torsional stiffness of said decoupling device (14) when the speed of the vehicle increases.

10 4. Vehicle according to any of the preceding claims, characterized in that said control unit (25) is configured to activate said second actuating means (15) with a time delay with respect to said first actuating means (23).

15 5. Vehicle according to claim 4, characterized in that said control unit (25) is configured to increase said time delay as the speed of the vehicle increases.

20 6. Vehicle according to any of the preceding claims, characterized by comprising a second steering wheel (3), in that said first and second steering wheels are front wheels, and in that said steering wheels are connected to said frame (2) to tilt in a coordinated way with said frame (2).

7. Vehicle according to claim 6, characterized

by having no more than three wheels, one of which is a non-steering wheel tilting with said frame (2).

8. Vehicle according to any of the preceding claims, characterized in that said decoupling device
5 (14) comprises stop means (18, 19, 20) configured to define a maximum decoupling angle between said control means (11) and said steering wheel (3).

9. Vehicle according to claim 8, characterized in that said decoupling device (14) comprises a
10 torsional spring (16) interposed between said control means (11) and said steering wheel (3).

10. Vehicle according to claim 9, characterized in that said control unit (25) is configured to detect the torque applied to said control means (11) by the
15 driver.

11. Vehicle according to any of the preceding claims, characterized in that said control unit (25) comprises a feedforward control (39) to control said first actuating means (23).

20 12. Vehicle according to claim 11, characterized in that said control unit (25) comprises a feedback control (38) combined with said feedforward control (39) to control said first actuating means (23).

13. Vehicle according to any of the preceding

claims, characterized by comprising a lateral
accelerator (24) fixed to said frame (2) and
connected to said control unit (25), said control
unit (25) being configured so that said frame (2) is
5 tilted after said control means (11) are operated so
that the output of said lateral accelerator is not
zero in order to give to the user a feeling of
centrifugal force.

14. Control method for a vehicle comprising at
10 least one steering wheel (3), at least two other
wheels (3, 4), control means (11) suitable for being
directly operated by a driver to steer said steering
wheel (3), a frame (2) supported by said wheels (3,
4) and tiltable with respect to the ground when the
15 vehicle steers, first actuating means (23) to control
the angular position of said frame (2), a decoupling
device (14) decoupling the angular position of said
control means (11) to the angular position of said
steering wheel (3), second actuating means (15)
20 connected to said control unit (25) to control the
steering angle of said steering wheel (3) and a speed
sensor (24) connected to said control unit (25) to
measure the speed of the vehicle, said method
comprising the phase of enabling said actuating means

(23) when said control means (11) are operated by the driver and the phase of activating said second actuating means (15) depending on the speed measured by said speed sensor (24).

5 15. Control method according to claim 14, characterized by comprising the phase of varying the torsional stiffness of said decoupling device (14).

 16. Control method according to claim 15, characterized in that the phase of activating said
10 second actuating means (15) is such that said control unit (25) decreases the rotational stiffness of said decoupling device (14) when the speed of the vehicle increases.

 17. Control method according to any of claims 14
15 to 16, characterized in that said phase of activating said second actuating means (15) is such that said control unit (25) activates said second actuating means (15) at a given time delay with respect to said phase of activating said first actuating means (23).

20 18. Control method according to claim 17, characterized in that said phase of activating said second actuating means (15) is such that said time delay increases with the speed of the vehicle.

 19. Control method according to any of claims 14

to 18, characterized in that said vehicle comprises a lateral accelerator (24) fixed to said frame (2) and by comprising the phase of tilting said frame (2) when said control means (11) are operated so that the
5 output of said lateral accelerator is not zero in order to give to the user a feeling of centrifugal force.

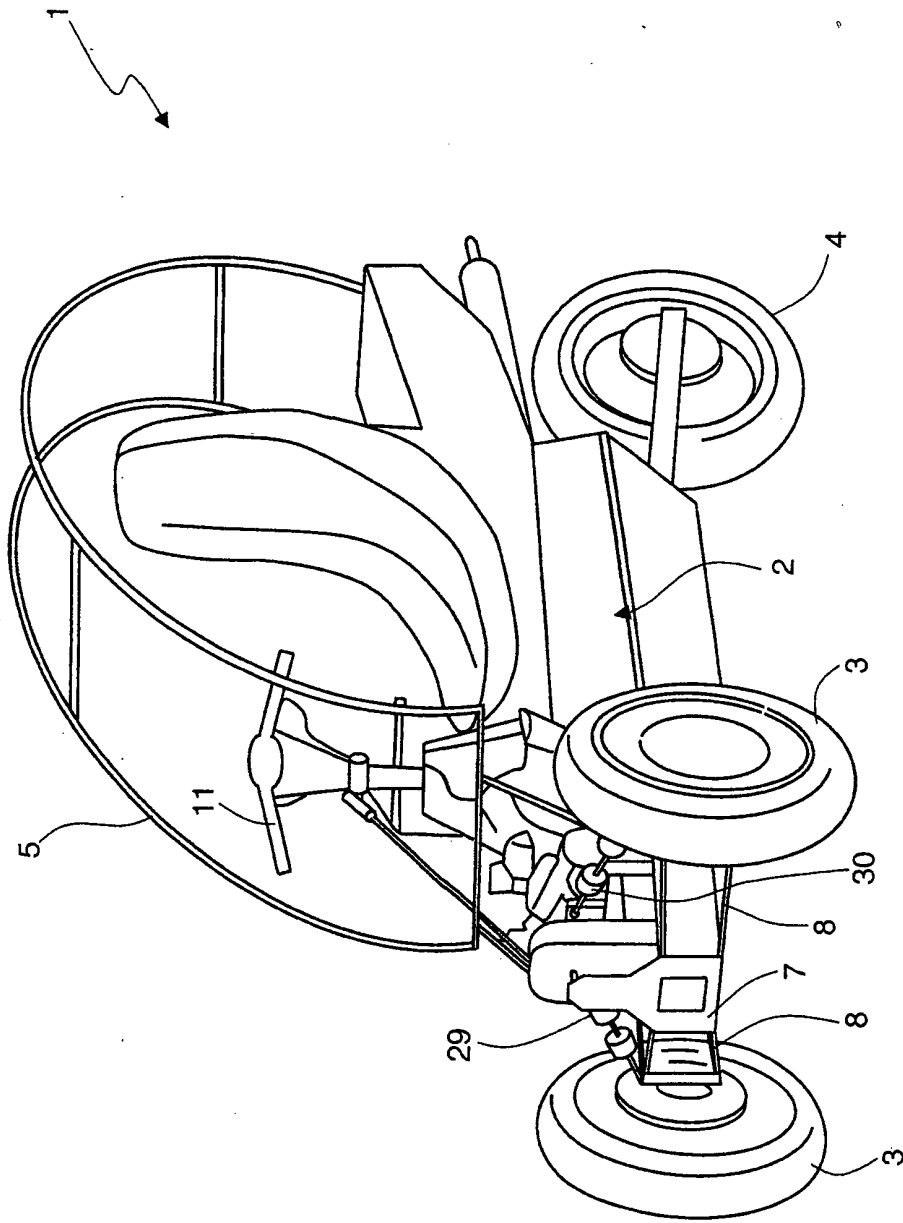

Fig.1

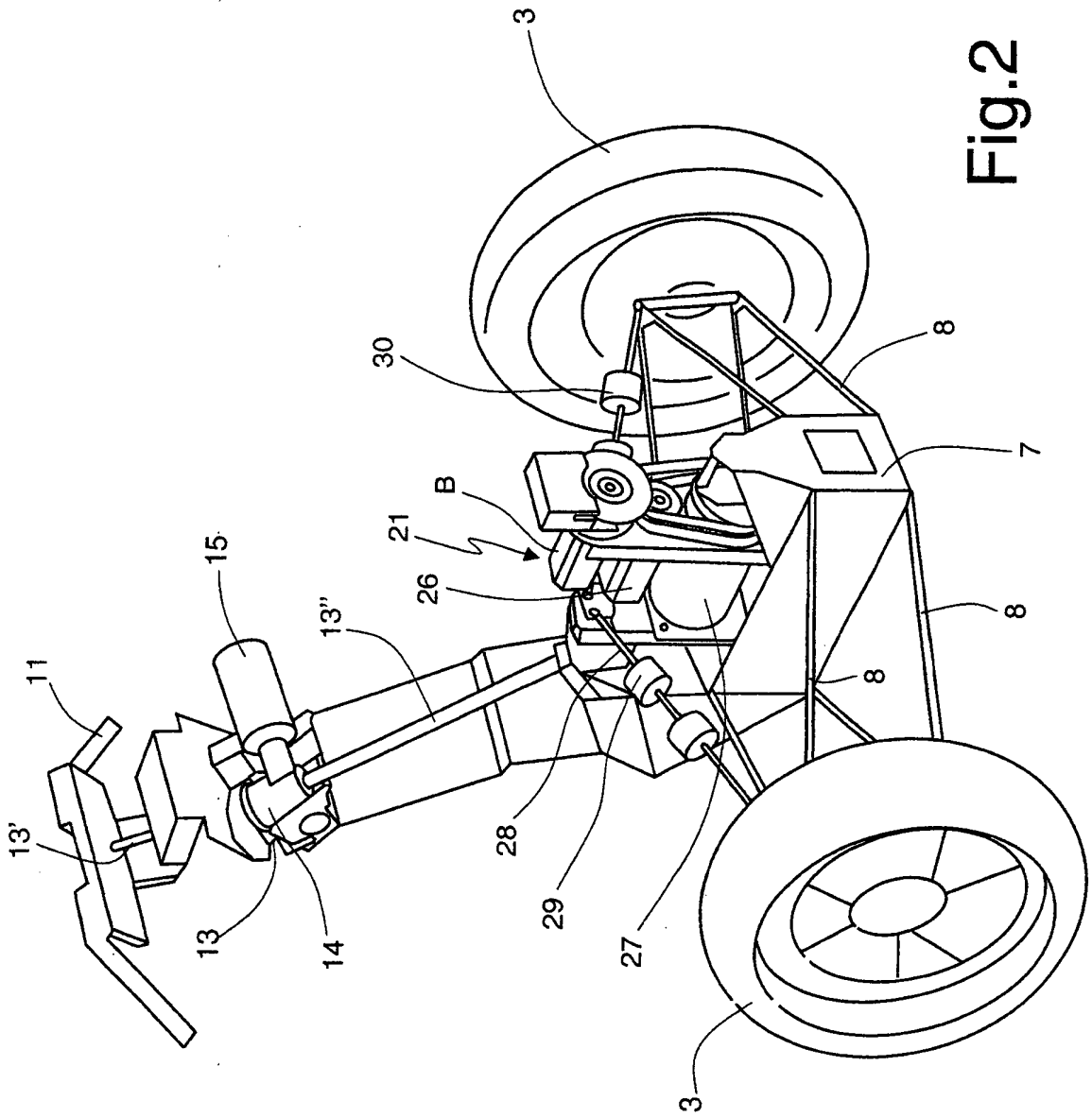

Fig.2

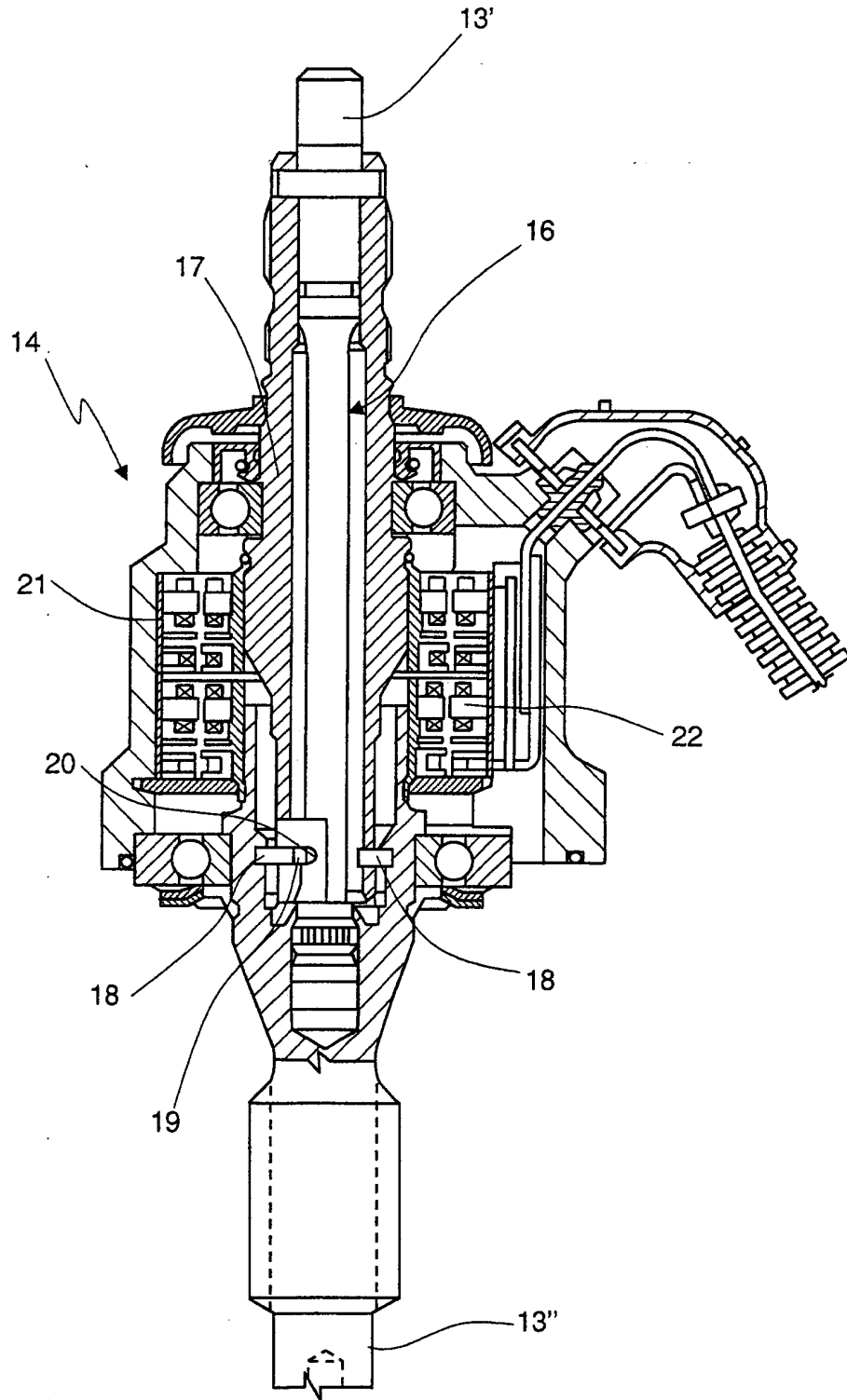

Fig.3

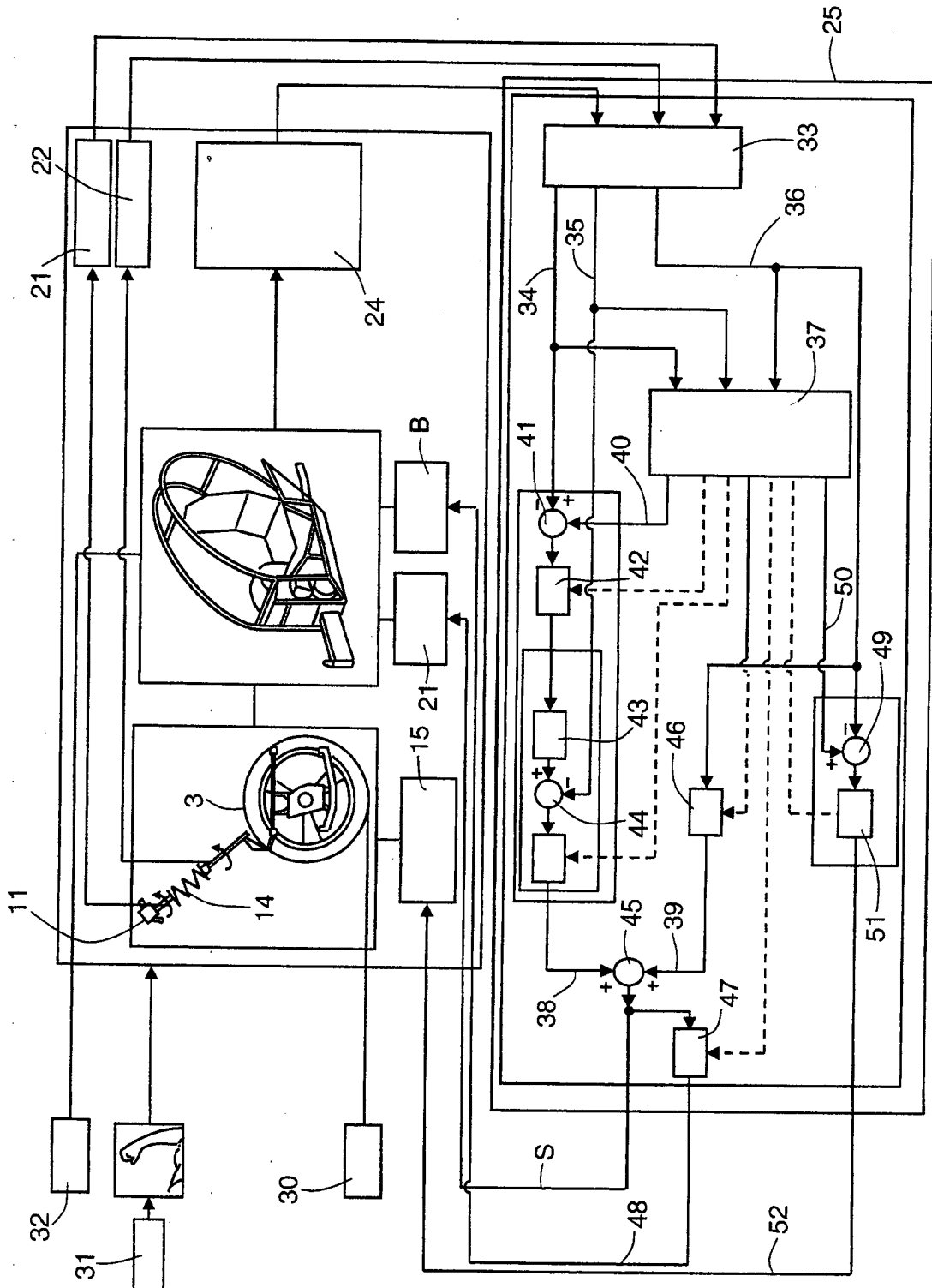

Fig. 4

INTERNATIONAL SEARCH REPORT

International application No
PCT/IT2009/000520

A. CLASSIFICATION OF SUBJECT MATTER
 INV. B62K5/04 B62K5/08
 ADD.
 According to International Patent Classification (IPC) or to both national classification and IPC

B. FIELDS SEARCHED
 Minimum documentation searched (classification system followed by classification symbols)
 B62K B62H

Documentation searched other than minimum documentation to the extent that such documents are included in the fields searched

Electronic data base consulted during the international search (name of data base and, where practical, search terms used)
 EPO-Internal, WPI Data

C. DOCUMENTS CONSIDERED TO BE RELEVANT

Category*	Citation of document, with indication, where appropriate, of the relevant passages	Relevant to claim No.
Y	WO 99/14099 A1 (BRINKS WESTMAAS BV [NL]; DEN BRINK CHRISTOPHER RALPH VA [NL]; KROONEN) 25 March 1999 (1999-03-25) claims; figures	1,6,7, 11-14,19
Y	WO 2004/074076 A2 (NIEDRIG FRANKLIN FERDINAND [CH]) 2 September 2004 (2004-09-02) claim 1; figures	1,6,7, 11-14,19
Y	WO 2006/130007 A2 (BRINKS WESTMAAS BV [NL]; VAN-DEN BRINK CHRISTOPHER RALP [NL]) 7 December 2006 (2006-12-07) claims; figures	6,7
A	WO 02/44008 A2 (SHOTTER NICHOLAS RICHARD [GB]) 6 June 2002 (2002-06-06) claims; figures	1

Further documents are listed in the continuation of Box C. See patent family annex.

* Special categories of cited documents :

A document defining the general state of the art which is not considered to be of particular relevance	*T* later document published after the international filing date or priority date and not in conflict with the application but cited to understand the principle or theory underlying the invention
E earlier document but published on or after the international filing date	*X* document of particular relevance; the claimed invention cannot be considered novel or cannot be considered to involve an inventive step when the document is taken alone
L document which may throw doubts on priority claim(s) or which is cited to establish the publication date of another citation or other special reason (as specified)	*Y* document of particular relevance; the claimed invention cannot be considered to involve an inventive step when the document is combined with one or more other such documents, such combination being obvious to a person skilled in the art.
O document referring to an oral disclosure, use, exhibition or other means	*8* document member of the same patent family
P document published prior to the international filing date but later than the priority date claimed	

Date of the actual completion of the international search 27 July 2010	Date of mailing of the international search report 03/08/2010
---	--

Name and mailing address of the ISA European Patent Office, P.B. 5818 Patentlaan 2 NL - 2280 HV Rijswijk Tel. (+31-70) 340-2040, Fax: (+31-70) 340-3016	Authorized officer Grunfeld, Michael
---	---

INTERNATIONAL SEARCH REPORT

Information on patent family members

International application No

PCT/IT2009/000520

Patent document cited in search report	Publication date	Patent family member(s)	Publication date	
WO 9914099	A1	25-03-1999	AU 732524 B2	26-04-2001
			AU 9189398 A	05-04-1999
			BR 9812312 A	12-09-2000
			CA 2302684 A1	25-03-1999
			CN 1269758 A	11-10-2000
			DE 69813258 D1	15-05-2003
			DE 69813258 T2	29-01-2004
			EP 1015292 A1	05-07-2000
			ES 2195386 T3	01-12-2003
			JP 3272347 B2	08-04-2002
			JP 2001516673 T	02-10-2001
			NL 1007045 C2	25-03-1999
			NL 1007045 A1	17-03-1999
			PL 339346 A1	18-12-2000
			PT 1015292 E	29-08-2003
			RU 2205122 C2	27-05-2003
US 6328125 B1	11-12-2001			
WO 2004074076	A2	02-09-2004	AT 401236 T	15-08-2008
			CN 1750964 A	22-03-2006
			DK 1597137 T3	03-11-2008
			EP 1597137 A2	23-11-2005
			JP 2006517882 T	03-08-2006
			US 2006169009 A1	03-08-2006
WO 2006130007	A2	07-12-2006	AU 2006253151 A1	07-12-2006
			CA 2610615 A1	07-12-2006
			CN 101203414 A	18-06-2008
			EP 1885593 A2	13-02-2008
			JP 2008545577 T	18-12-2008
			US 2009312908 A1	17-12-2009
WO 0244008	A2	06-06-2002	AU 1619502 A	11-06-2002
			EP 1339599 A2	03-09-2003
			EP 2196386 A2	16-06-2010