

Noninvasive Solution for Electrochemical Impedance Spectroscopy on Metallic Works of Art

Original

Noninvasive Solution for Electrochemical Impedance Spectroscopy on Metallic Works of Art / Corbellini, Simone; Parvis, Marco; Grassini, Sabrina. - In: IEEE TRANSACTIONS ON INSTRUMENTATION AND MEASUREMENT. - ISSN 0018-9456. - STAMPA. - 61:5(2012), pp. 1193-1200. [10.1109/TIM.2011.2175816]

Availability:

This version is available at: 11583/2496664 since:

Publisher:

Institute of Electrical and Electronic Engineers, Inc.

Published

DOI:10.1109/TIM.2011.2175816

Terms of use:

This article is made available under terms and conditions as specified in the corresponding bibliographic description in the repository

Publisher copyright

(Article begins on next page)

Non-invasive solution for Electrochemical Impedance Spectroscopy on metallic works of art

Simone Corbellini, Marco Parvis, *Fellow, IEEE*, Sabrina Grassini

Abstract— *Metallic works of art of cultural relevance are continuously subjected to corrosion as the environment becomes increasingly polluted. A fast and simple method to in-situ assess the conservation conditions is therefore required. This paper describes the development and performance of dry and gel-based electrodes which can be used to assess the surface conservation state without the need to move the artifacts and which do not cause any damage to them. The electrodes can be used with a portable electrochemical impedance spectroscopy system, without employing electrochemical cells. The proposed solution does not provide all the information one can obtain using an electrochemical cell, but however it can discriminate between protective coatings. It can be used to assess the protective capability of corrosion products layers and natural patinas and it can therefore enable a non-invasive routine surface assessment to be conducted that could be extremely useful for people working in the field of conservation of Cultural Heritage.*

Index Terms— *Coatings, Impedance measurements, Plasma Sputtering, Cultural Heritage, corrosion*

I. INTRODUCTION

Metallic artifacts suffer from corrosion phenomena due to their interaction with the surrounding environment. The severity of the phenomenon depends on several different aspects, such as the presence of electrolytes and gaseous pollutants, which in some cases may lead to great damage even over a short period of time. Different coatings can be employed to protect objects and increase their life, but the coatings themselves also suffer from degradation and they can make the corrosion phenomena worse unless they are continuously monitored and/or replaced. The decision of whether to employ a protective coating and its choice are therefore critical issues.

The conservation state of a surface and the coating protective capabilities can obviously be assessed by means of advanced analytical techniques, such as Atomic Force Microscopy (AFM), Scanning Electron Microscopy (SEM), X-ray Diffraction (XRD), Raman Infrared Spectroscopy (RIRS) Fourier Transform Infrared Spectroscopy (FTIR) and Electrochemical Impedance Spectroscopy (EIS) [1], [2], [3].

Most of these techniques are destructive and difficult to use as they require cutting off a sample of material and taking it to a laboratory. EIS, from this point of view, is particularly attractive since, in principle, it can be used in situ and, potentially, also on precious artifacts.

EIS consists of the measurement of the amplitude and phase of the surface impedance of a metallic object at

different frequencies, usually in 1 mHz to 100 kHz range, in order to highlight the barrier properties of the surface layer. The measurement is usually performed by means of an electrochemical cell, by stimulating the sample with a small alternating voltage, of 10 mV to 100 mV [4]. EIS consequently provides a small perturbation to the corroding system and a reasonable fast response.

Specific portable devices have been developed to allow researchers to perform EIS measurements in situ [5], [6], [7]. However some problems that can prevent the use of this technique on cultural works of art still remains mainly due to the electrolytic solution that is employed for the EIS, which can increase the corrosion rate and irreversibly damage the artefact surface. This problem can be reduced by performing the measurements using mineralized water, which although free of corrosive ions can penetrate the small pores that are present in the layer of corrosion products and/or in the protective coating. However the problem of employing and fixing an electrochemical cell to a work of art still remains.

This paper describes two approaches, which avoid the use of electrochemical cells and overcome the previously mentioned problems though at the expense of a reduced investigation capability. These solutions which are based on soft rubber electrodes and on conductive gels prevent one from obtaining all the data available from an electrochemical cell, but do allow enough information to be obtained to assess the conservation state of the artefact.

Both these approaches should allow one to perform impedance measurements without affecting the coating surface and they can therefore also be used on precious objects. The soft electrodes remain in contact with the surface even in the presence of small irregularities and this permits meaningful measurements to be obtained also on very thin layers, such as the coating deposited via Plasma Enhanced Chemical Vapour Deposition (PECVD), where electrode distances of few tens of nanometers can alter the results to a great extent [8], [9].

However, soft rubber electrodes are not able to penetrate coating pores or defects, therefore their measurements are only representative of the outer coating profile; a conductive gel, on the contrary, is able to penetrate some micropores and highlight the presence of coating defects.

Although the proposed approaches are not able to provide information on the ionic charge transfer phenomena they can be considered very useful to highlight dangerous conservation conditions and to assess the protective capability of different coatings applied directly to a real artefact.

S. Corbellini and M. Parvis are with the Dipartimento di Elettronica, S. Grassini is with the Dipartimento di Scienza dei Materiali e Ingegneria Chimica, Politecnico di Torino, corso Duca degli Abruzzi, 24 - 10129 Torino (Italy); phone: +39 011 5644114, fax: +39 011 5644217, e-mail: marco.parvis@polito.it

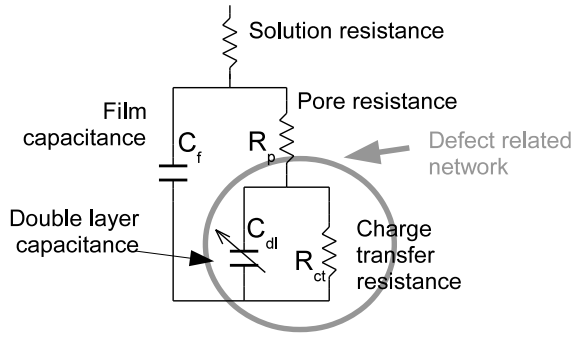

Fig. 1. Simplified equivalent circuit model of a metal/coating/electrolyte system. The model is composed of two sections: on the right, the network which describes the surface defects i.e. the behavior connected to the presence of pores in the coating present on the surface. On the left, the capacitor which takes into account the protective behavior of the coating.

II. ELECTRODE DESIGN AND CHARACTERIZATION

A. EIS principle and electrochemical cells

The capability of EIS to assess the surface properties is related to the capability of different frequencies to highlight different phenomena. Metallic surfaces are physical objects that are extremely difficult to describe. They can be considered as multilayer structures affected by diffusion phenomena connected to the micropores and to the ionic charge transfer phenomena. Equivalent simplified electric models based on the use of lumped elements are usually employed to obtain some understanding of the phenomena [10], [11]. Fig. 1 shows, as an example, a simplified model, which can be used in the case of a single prevalent layer. The model is composed of two sections: on the right, the network that describes the surface defects i.e. the behavior connected to the presence of pores in the corrosion layer. On the left, the film capacitance C_f , which takes the protective behavior of the layer into account: in the case of a good coating, this is the only component which is present, as the pore resistance R_p , is extremely high. In this case, the behavior is that of a capacitor, and the impedance tends to extremely high values for low frequencies. The absence of a path for the DC current rules out the possibility of corrosion, and this explains the protection capabilities of the coating.

The network used by the authors to describe the electrical behavior related to the charge transfer [12], i.e. to the critical part for the corrosion phenomenon, is composed of the charge transfer resistance R_{ct} that is the resistance connected to the electrochemical reaction which occurs at the coating/substrate interface, and the double layer capacitance C_{dl} , which takes the diffusion phenomena into account. The diffusion phenomena, which constitutes an intrinsically distributed process are described by a Constant Phase Element (CPE), which models an impedance with a phase with a constant value of between -90° and 0° , i.e. with behavior midway between a capacitor and a resistor.

In the EIS measurement, the model parameters are iden-

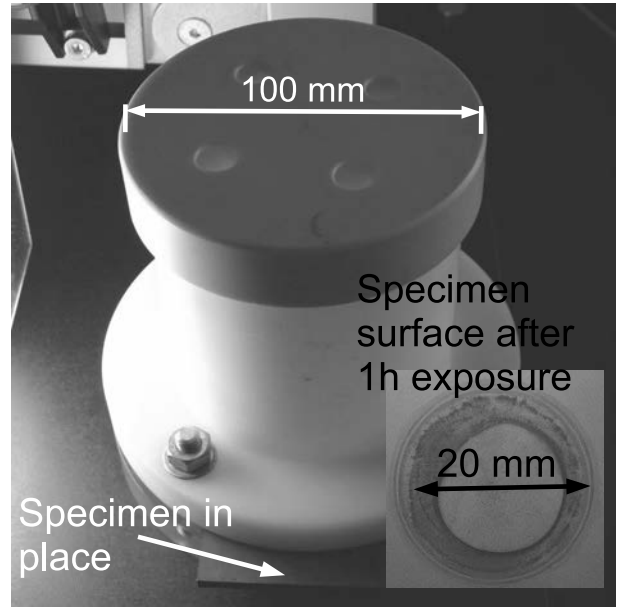

Fig. 2. Electrochemical cell employed in the lab to identify models like the one shown in Fig. 1. The inset shows the specimen surface, which is clearly damaged after 1 h exposure.

tified by fitting the model to the measured impedance.

In order to identify the diffusion components correctly, the measurements have to be extended to very low frequency values i.e. as low as 0.01 Hz or even 0.001 Hz. This is necessary to allow the solution to diffuse in the micropores, thus can be very slow process and results in long measurement sessions, which can last more than one hour. An electrochemical cell, similar to the one shown in Fig. 2, is used in conventional EIS tests where a specimen is clamped and exposed to an electrolytic solution. Unfortunately the exposure of a sample to the solution, even for just a couple of hours, can dramatically damage the surface, as shown, as an example, in the inset in Fig. 2 where the corrosion of an iron sample after one hour of immersion in the aggressive solution can be observed.

In order to avoid damaging the surface, the electrolytic solution should be replaced with dry electrodes, but this of course would make it impossible to investigate the behavior of the micropores. As an alternative, the electrochemical solution could be substituted with a low aggressive conductive gel. Any possible solution, naturally, has to face another important problem connected to the surface roughness of the works of art: protective coatings and any surface corrosion layers do not tend to grow uniformly, therefore a flat surface cannot be expected. An electrochemical cell does not suffer from this problem, since the solution is capable of following the surface, but other non-liquid electrodes are affected by this inconvenience.

The authors therefore decided to develop two electrodes, one that avoids the use of any solution and the other based on a low-mobility solution trapped in a gel. Both electrodes are flexible and can follow some of the surface irregularities.

B. Dry electrodes

Dry electrodes can be prepared either by employing conductive polymers, or by coating polymeric substrates with a conductive layer. The first solution is attractive, but most conductive polymers have a high resistivity. This can cause problems when the impedance to be measured is low i.e., at high frequencies, if C_f is high, and at any frequency if R_p has a low value. The authors decided to follow the latter approach by depositing a conductive layer through DC plasma sputtering. A gold target (purity 99.99%) was used, in conjunction with argon, at a pressure of 5 Pa as the discharge gas. The depositions were carried out using a current of 120 mA for a duration of 800 s to obtain a nominal thickness of the gold layer of about 200 nm.

The dry electrode requires the selection of a base material which must be soft enough to follow the sample irregularities without leaving open spaces. Unfortunately, really soft materials can only be created by generating a foam structure, which tends to have a non-uniform surface with consequent risk of the electrode surface roughness reducing the effective contact area i.e. the area of the electrode which is actually in contact with the specimen[13]. Two kinds of materials were tested: a rubber material, which shows a compact surface and a Young modulus of about 3 MPa, and a low density closed-cell polyurethane with a Young modulus of about 0.3 MPa. This second material shows important deformations which should warrant good conformability, but it has a surface roughness, which could reduce the effective contact area.

The first electrode was prepared starting from a stiff 3.5 mm thick rubber sheet, while the other electrode was prepared starting from a closed-cell polyurethane sheet with an uncompressed thickness of 5 mm. Both materials were cut in 1 cm square and cleaned with isopropanol. After the deposition of the gold film on one of the surfaces, a silver-filled epoxy resin was used to create a conductive path on side of the rubber, up to the opposite face. In this way, it was not necessary to repeat the sputtering to completely cover the electrodes, thus reducing gold consumption.

Fig. 3 shows an example of the two dry electrode types. It is easy to see the different aspects of the electrode surfaces and the silver lateral conductive paths.

Once the electrodes had been prepared, tests were performed to assess their behavior, as a function of the load pressure, which both changes the mechanical dimension and the effective contact area [13]. To this aim, tests were performed by using a diamond-like carbon (DLC) coated disk [14] of known coating thickness and dielectric constant. The measurements were performed with a cell on which it is possible to adjust the load pressure in the range of 10 kPa, corresponding to an almost undeformed electrode, to 180 kPa, corresponding to a very deformed electrode [13].

Fig. 4 shows the results obtained with the two electrodes loaded with increasing pressure. The measured equivalent area is 40% to 90% of the apparent area depending on the applied pressure. The repeatability of the equivalent area,

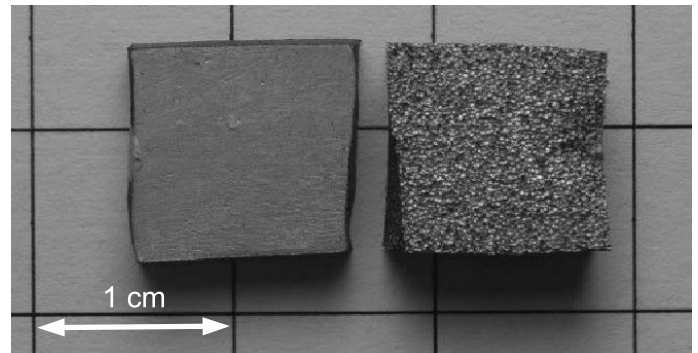

Fig. 3. Picture of the two dry electrodes types. On the left, the stiffer rubber electrode; on the right, the softer closed-cell polyurethane electrode, which has a much more irregular surface.

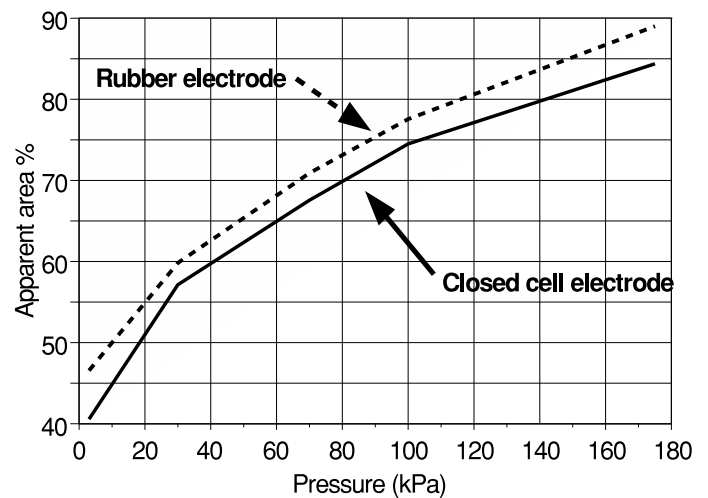

Fig. 4. Estimated effective contact area as a function of the applied pressure in the case of a flat object.

which is mainly due to the rubber relaxation phenomena [13], is of about 5%. One should note that the estimated values depend not only on the electrode material, but also on the surface flatness of the object and can, therefore, only be used in the case of flat surfaces; lower values are expected in the case of rough surfaces.

C. Gel-based electrodes

Commercially available disposable surface electrodes, usually employed for ECG measurements were used in this study (*Kendall Tyco ARBO*). These electrodes, which are cheap and easily available, are composed by an Ag/AgCl electrode surrounded by a conductive gel, whose resistivity is about 100 Ωm . The gel is surrounded by an adhesive material (Fig. 5) which is used to fix the electrodes. The electrodes have a total diameter of about 25 mm, a gel diameter of about 10 mm and an Ag/AgCl disc with a diameter of about 10 mm.

The cross section image (right part in fig. 5) shows that the gel under the tip is about 600 μm thick, while it is much thicker in the remaining part. Although this is irrel-

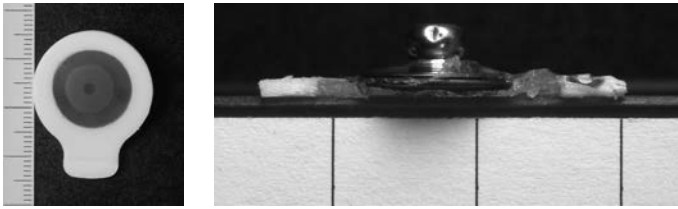

Fig. 5. Pictures of the ECG gel electrodes. On the left, view from the bottom; on the right, a lateral cross-section image, in which the gel area and the silver tip can be seen.

evant for conventional ECG use, it causes problems in the EIS applications, since it becomes difficult to compute the electrode equivalent area: if the resistivity of the coating below the electrode is low, the current tends to concentrate just below the electrode tip, due to the high gel resistivity; on the contrary, if the coating has a higher resistivity than the gel, the current lines also tend to flow in the gel.

This actually changes the equivalent surface, as a function of the coating resistivity, and requires a correction. The necessary correction can be estimated by modeling the electric field under the tip through a finite element analysis (FEA).

To this aim, the authors modeled the tip and simulated the field using a free commercial software [15]. The simulated field, in the case of low and high coating resistivity, is shown in fig 6. The top image refers to a case with low coating resistivity: the current extends only marginally outside the tip; the bottom image instead refers to a high resistivity coating: in this case, the current lines extend over almost all the entire gel area.

By integrating the current field it is possible to estimate the equivalent area as a function of the coating resistivity. Fig. 7 shows the simulation results. The correction factor ranges from 1.4 to about 2.6, as the resistivity of the coating layer varies from 1 Ωm to $10^7 \Omega\text{m}$

Fig. 8 shows the correction factor as a function of the measured resistance and can be used to correct the results during use of the electrode. The plot shows a minimum measured resistance of about 600 Ω , which corresponds to the gel resistance. This means that the gel electrode cannot be used to measure very low resistance values, even though this is not a drawback in real conditions, since the expected impedance values are much higher than this value. The equivalent area becomes almost constant when the measured resistance is greater than 100 k Ω i.e when all the gel area is uniformly interested by the current field.

III. EXPERIMENTAL RESULTS

A. EIS system

In order to test the electrode performance in comparison with the standard electrochemical cell, tests were performed on both highly protective coatings and on natural corrosion layers. All tests were performed using a portable instrument developed by the authors [6], which has an amplitude uncertainty of 1.5% to 4%, depending on the

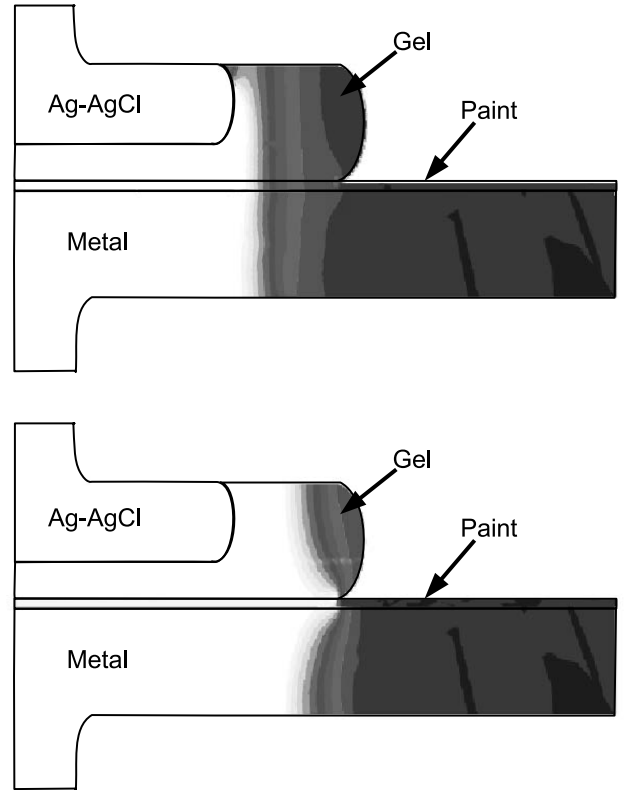

Fig. 6. ECG current field distribution in the case of low (top image) and high (bottom image) coating resistivity. The field is shown in gray levels with white as the highest value and dark grey the zero value. In the case of a low resistivity coating, the current extends only marginally outside the tip diameter; in the case of a high resistivity coating, the current lines extend over almost the entire gel area.

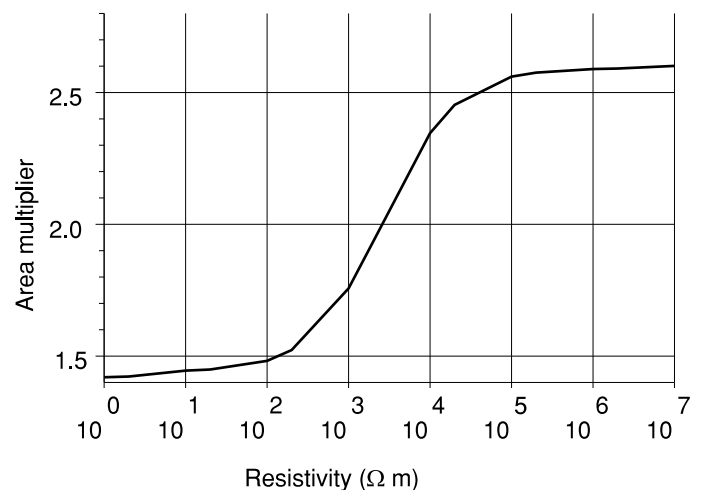

Fig. 7. Results of the FEA simulation: area multiplier correction factor as a function of the coating resistivity.

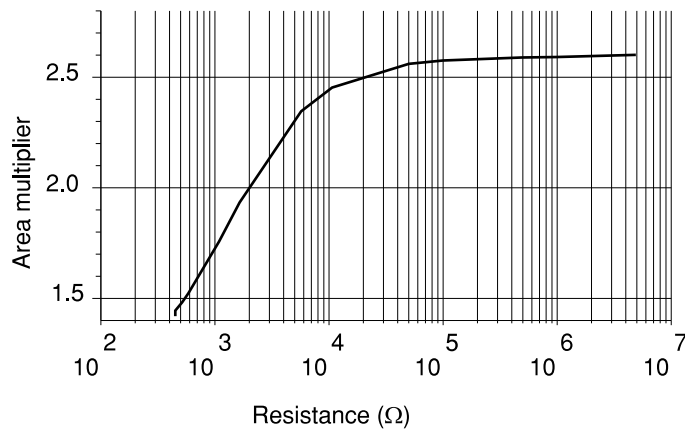

Fig. 8. Area correction factor as a function of the measured resistance. The gel resistance of about 600Ω prevents the gel electrode from being used for very low resistance values.

impedance value and a phase uncertainty of 1° to 3° . The EIS system is capable of doing measurements for frequencies in the range of 10 mHz to 40 kHz and is capable of compensating the free corrosion potential.

B. Electrode performance on highly protective coatings

In order to test the electrode performance for highly protective coatings, tests were performed using a specimen composed of a 2 mm thick iron sheet painted with a highly protective layer that should appear as a pure capacitor during the impedance measurement. A $70 \mu\text{m}$ thick polyurethane coating cured in an oven after deposition to increase the cross-linking degree and obtain a compact layer was adopted. The coating is expected to have a relative dielectric constant in the range of 4 to 6 and resistivity in excess of $10^{10} \Omega\text{m}$.

Fig. 9 shows the impedance measured by means of the electrochemical cell, with the two dry electrode types and with the gel-based electrode. The dry electrodes were pressed onto the specimen by using an electrode holder which applies a pressure of about 100 kPa, while no pressure was applied to the gel electrode after its positioning. The traces for the dry and gel electrodes have been corrected for the effective area and all the traces have been scaled to an area corresponding to 1 cm^2 . The results confirm the highly protective behavior of the coating, which can be described as the film capacitance (C_f) in parallel with a very high, not measurable ($> 100 \text{ G}\Omega$) R_p resistance. Also the effect of the solution resistance R_s , which is of the order of 600Ω for the ECG electrode, as measured in the previous section and lower for the electrochemical cell, is not visible in the plots. Table I shows the film capacitance that can be estimate by fitting the impedance spectra with the equivalent circuit in fig.1. The closed-cell electrode, the gel-based electrode and the electrochemical cell give rather similar results, while the rubber electrode overestimates the film capacitance, probably because of rubber relaxation phenomena [13].

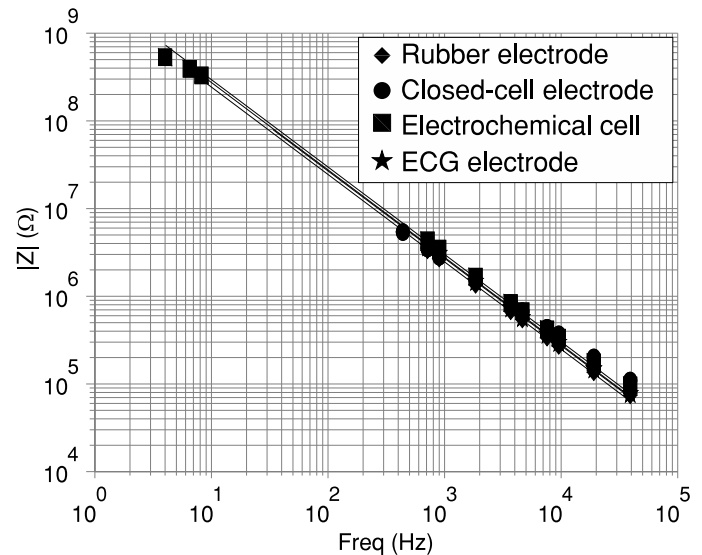

Fig. 9. Impedance recorded on the iron sheet coated with a highly protective coating. The EIS measurements were performed employing the dry and gel electrodes and with a convensional electrochemical cell filled with mineral water.

TABLE I
FILM CAPACITANCE VALUES ESTIMATED BY FITTING THE DATA OF FIG. 9

	Rubber	Closed-cell	ECG	Electroch. Cell
C_f (pF)	65	58	55	54

The results confirm that both the gel-based and the closed-cell electrodes can be used in place of the conventional electrochemical cell in the case of highly protective coatings. The rubber electrode instead, due to the rubber stiffness, is problematic.

C. Electrode performance on a corroded iron sample

Other laboratory tests were performed on a completely different sample, composed of a badly corroded specimen. The specimen, shown at bottom of fig 10, is an ARMCO iron disk (50 mm in diameter) exposed to the outdoor atmosphere for 10 years and coated with a several micrometers thick corrosion product layer. This sample was selected as an extreme example to see whether the low aggressive electrodes are able to provide useful data in these conditions. Measuring samples of this type may require special attention due the their possible surface fragility. In the case of the dry electrodes, special attention must be paid to avoid tangential forces when positioning the electrodes and to avoid excessive compression forces. The authors did not encountered problems by limiting the pressure to about 100 kPa as described in the previous section. In the case of the gel electrode, problems may arise when the electrode is removed due to its adhesive, which may detach part of the surface. The pre-conditioning described in the next paragraph greatly reduce this problem.

A stabilization time of one hour was used in the case of

the ECG electrode and electrochemical cell before taking the measurements to allow the free corrosion potential to set.

Fig. 10 shows the results obtained using the closed-cell, the gel-based electrodes and the electrochemical cell. As expected, the closed-cell electrode is not able to follow the surface roughness and an abnormal behavior can be observed, while the gel-based electrode reacts to the presence of pores although it shows a much higher impedance than the electrochemical cell, which has been used as a reference value. The difference is obviously due to the difficulty the polymeric gel has in penetrating inside the porous corrosion product layer which, as already mentioned, is remarkably thick.

An easy way of diminishing this problem it to pre-condition the sample surface by wetting it with mineralized water. The water penetrates the pores overcoming the reduced gel mobility. Since the pore depth is limited compared with the gel thickness, even low conductivity mineral water that does not expose the sample to corrosion hazards can be used. The pre-conditioning also reduces the adhesive force; this is usually not a problem, since the electrode are not subjected to noticeably stresses, and helps avoiding problems when the electrode itself is removed. In addition, the limited amount of water allows it to dry in a few minutes on exposure to air, therefore the pre-conditioning can be considered safe in most cases. The trace obtained one hour after the gel electrode had been positioned on the pre-conditioned area shows that the gel electrode behaves like the electrochemical cell, at least for frequencies as low as 10 Hz. It is therefore possible to hypothesize that the traces can be used successfully to estimate most of the coating properties. The pre-conditioning cannot obviously be used to extend the gel-based measurement capabilities to very low frequencies, where the behavior is connected to the characteristics of the micropores and to the ionic charge transfer phenomena. However this kind of information is mostly required when dealing with not coated surfaces in order to study the early beginning of the corrosion process.

D. In situ measurements

On the basis of the results obtained in the laboratory, the low-invasive electrodes were then used in situ in a measuring campaign on the iron chains of the Amiens Cathedral in the north of France.

The Cathedral dates back to the fourteen century and its roof is sustained by iron chains installed over different periods after the Cathedral has been built. The chains, which were not protected in any way according to common practice at the time of construction, are inside the Cathedral and thus not directly exposed to rain, but are subjected to the so-called wet-dry corrosion cycle [16]. Due to the thermal inertia of the iron, when warm and humid air comes in contact with the still cold chains, condensation may occur on the chains and then is followed by a drying when the temperature of the chains increases. This cycle, repeated for hundreds of years, may lead either to the formation of a thick protective layer or to chain cor-

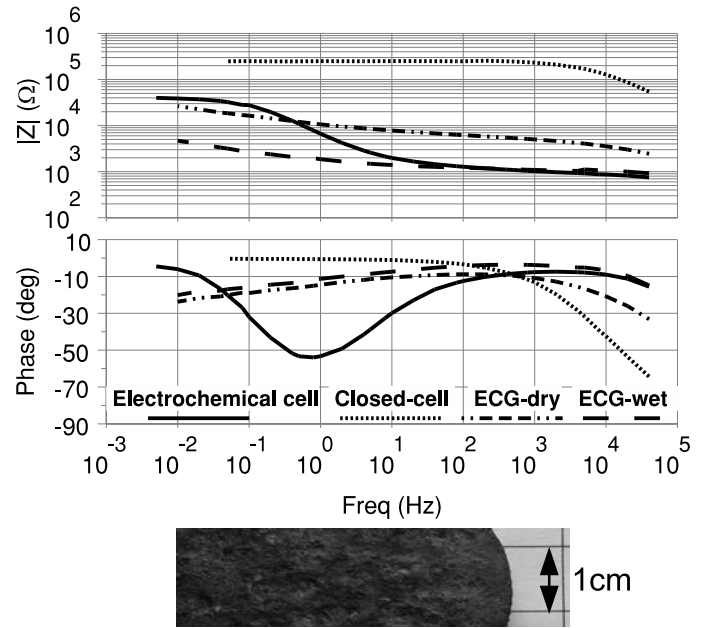

Fig. 10. Impedance of the corroded specimen obtained using the different techniques. All the traces have been corrected for the estimated electrode area and scaled to an equivalent surface of 1 cm². Two traces are shown for the gel electrode. One ECG measurement has been taken simply attaching the electrode to the surface (ECG-dry), the other after a pre-conditioning of the surface by wetting the area with mineral water (ECG-wet). A picture of the specimen, which is a heavily corroded iron disc with surface irregularities of about 0.5 mm, can be seen at bottom.

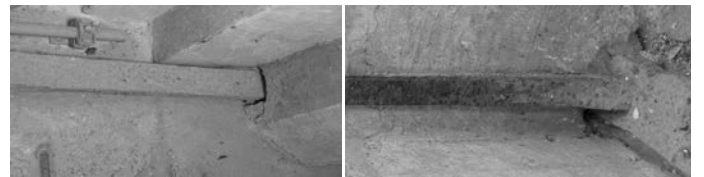

Fig. 11. Pictures of two iron chains from the Amiens Cathedral in France. The left chain appears well preserved while the right chain shows corrosion in evolution. Both chains are in their original state, as installed in the fourteen century, without any protective coating. The distribution of the corroded chains does not follow a specific scheme.

rosion. The corrosion layer, which is constituted by iron oxides and oxy-idroxides, such as goethite, lepidocrocite, maghemite, and akaganeite, organized in a very complex structure, may remain stable for long periods, but may also become unstable if something in the environment changes, and loose its protective properties. There is great concern about the possibility of sudden corrosion due to the air pollution, which would damage the chains. Random spots of dangerous corrosion processes have in fact already been observed (see figs. 11 and 12) apparently without any specific reason.

Some microsamplings of the chains were performed to establish the composition of the corrosion layer, but despite the deep chemical and microstructural analysis, several questions about the corrosion mechanisms and the

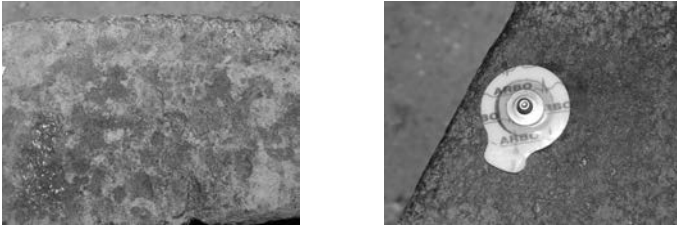

Fig. 12. Details of two chain surfaces, on the left a well preserved chain; on the right, an example of chain affected by corrosion. The picture on the left shows a gel-based electrode in place. The positioning of the electrode is easy even in the presence of the space constraints connected to the chain installation.

presence of electrochemically active species remained unresolved. Furthermore it was not possible to sample all the artifacts or to plan repetitive samplings of the chains.

An in situ EIS was considered an interesting alternative. However, the use of an electrochemical cell on the chains was almost impossible even though ad-hoc cells were designed for the different chains due to the space constraints connected to position of the chain.

Gel-based electrodes instead appeared an easy and convenient alternative. A measuring campaign was therefore set up with the aim of trying to predict any possible dangerous corrosion phenomena.

The tests highlighted the presence of two different kinds of behavior, which are clearly described by the traces in Fig. 13 and 14.

Fig. 13 refers to chains 46-east and 51-west, which appear to be well preserved iron chains. The impedance at low frequency is well above 100 k Ω , with a nearly resistive phase, which is connected to low values of the double layer capacitance. These high impedance values [4] suggest the coating is quite compact, capable of isolating the iron underneath, and of protecting it from corrosion.

Fig. 14 instead refers to chains 18-north and 30-south. The impedance at low frequency is well below 100 k Ω , with a marked phase reduction in the 10 Hz – 100 Hz frequency range, which is connected to the double layer capacitance. These low impedance values, coupled with the phase trend, suggest the coating is porous, incapable of isolating the iron underneath, and thus exposing it to corrosion. Most of the chains with this type of impedance behavior appear corroded, however some of the low-impedance chains appear apparently well preserved.

The reported traces refer to chains which were subjected to sampling and chemical and morphological characterization using a Scanning Electron Microscope equipped with an Energy Dispersive X-Ray Spectrometer (SEM-EDS). Good electrochemical behavior and high stability of the corrosion products layer were observed on the iron chains on which the SEM-EDS analyses showed the presence of phosphorus, which prevents corrosion; on the contrary, low impedance values highlighted a high corrosion rate where the SEM-EDS analysis showed the absence of phosphorus in the alloy.

The obtained results confirm that the gel-electrodes can

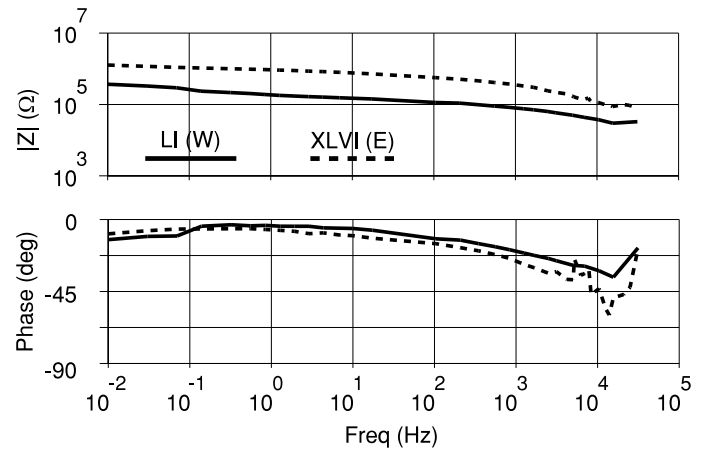

Fig. 13. Bode plots recorded for chains 46-east and 51-west. All the traces are scaled to an equivalent area of 1 cm². The impedance at low frequency is well above 100 k Ω with a nearly resistive phase, which is connected to low values of the diffusion capacitance. These high impedance values suggest the coating is quite compact, capable of isolating the iron underneath and of protecting it from the corrosion. The Roman numbers next to the traces refer to the chain catalog number. Irregularities appear on the traces at high frequency due to the electromagnetic interference with the church anti-pigeon electric fence.

be used successfully to discriminate between protective corrosion layers of different extent, and to highlight the presence of risky areas due to porous layers, before evident corrosion occurs.

IV. CONCLUSIONS

Dry and gel-based electrodes, coupled with a portable EIS system, can be an interesting solution to assess the status of protective coatings and corrosion layers on metallic artifacts. Both electrode types can be used on rough surfaces and can be used in situ where conventional electrochemical cells cannot be employed.

Dry electrodes do not damage the surface, but do not provide any information on diffusion phenomena. They can be used mainly to assess highly protective coatings, but can also lead to an underestimation of the risks if the coating has micro-pores.

Commercially available ECG gel-type electrodes are a cost-effective, minimally invasive solution. They provide partial, though usually sufficient information on the diffusion, provided that a pre-conditioning involving wetting the surface with mineral water 1 h before the measurement is adopted.

This moistening is required as ECG gel is designed for the skin and has low ion mobility. Tailored gel electrodes, which are more suitable for the specific application, with high-mobility, low-aggressive gel and low-aggressive adhesives are being designed, and these might permit to remove then necessity of the pre-moistening phase.

The described electrodes have been used in situ in the Amiens Cathedral, France. A non invasive monitoring of the internal iron chains has been conducted and apparently well preserved chains, which are in danger of possible cor-

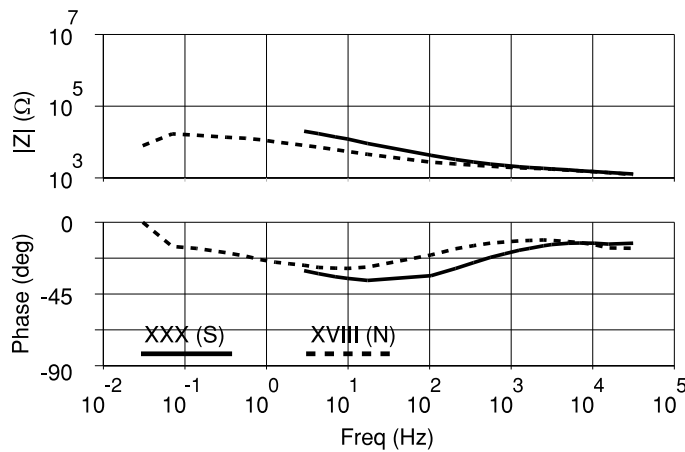

Fig. 14. Bode plots recorded for chains 18-north and 30-south. All the traces are scaled to an equivalent area of 1 cm^2 . The impedance at low frequency is well below $100 \text{ k}\Omega$ with a marked phase reduction in the $10 \text{ Hz} - 100 \text{ Hz}$ frequency range, which is connected to the diffusion capacitance. These low impedance values, coupled with the phase trend, suggest the coating is porous, incapable of isolating the iron underneath and exposing it to corrosion. The Roman numbers next to the traces refer to the chain catalog number.

rosion due to the porous nature of their corrosion layers, have been identified. The proposed solution based on the gel electrodes cannot be used either to determine the corrosion layer thickness, its porosity, or its composition, but it can be extremely useful to isolate critical problems, which may be studied by using other, more sophisticated and/or invasive, approaches.

V. ACKNOWLEDGEMENTS

The author would like to thank Dr. Philippe Dillmann of CEA/CNRS Saclay, France, for the helpful discussions and his contribution to the Amien measuring campaign.

REFERENCES

- [1] R. W. Clarke, S.M. Blackshaw, *Conservation of iron, Maritime Monographs and Reports*, Maritime Monographs and Reports, National Maritime Museum, n. 53, 1982.
- [2] G.M. Ingo, et al., "Large scale investigation of chemical composition, structure and corrosion mechanism of bronze archaeological artefacts from Mediterranean basin", *Applied Physics A*, n. 83, pp. 513-543, 2006.
- [3] E. Angelini, A. Batmaz, A. Cilingiroglu, S. Grassini, G.M. Ingo, C. Riccucci, "Tailored analytical strategies for the investigation of metallic artefacts from the Ayanis Fortress in Turke", *Surface and Interface Analysis*, n. 42, pp. 675-679, 2010
- [4] Gamry Instruments, *Electrochemical Impedance Spectroscopy Theory: A Primer* available at: http://www.gamry.com/App_Notes/EIS_Primer/EIS_Primer.htm
- [5] A. Carullo et al., "Low-Cost Electrochemical Impedance Spectroscopy System for Corrosion Monitoring of Metallic Antiquities and Works of Art", *IEEE Trans. Instrum. Meas.*, vol. 49 no. 2, pp. 371-375, 2000.
- [6] E. Angelini et al., "Handheld-impedance-measurement system with seven-decade capability and potentiostatic function", *IEEE Trans. Instrum. Meas.*, vol. 55 no. 2, pp. 436-441, 2006.
- [7] E. Angelini, et al "Potentialities of XRD and EIS portable instruments for the characterisation of ancient artefacts", *Applied Physics A, Materials science & Processing*, vol. 55, pp. 643-649, 2006.
- [8] A. Carullo, S. Grassini, M. Parvis, "Measurement Procedures

for the Electrical Characterization of Oxide Thin Films" *IEEE Trans. Instrum. Meas.*, vol. 58, no 5, pp. 1398-1404, 2009

- [9] F. Fracassi et al., "Application of plasma deposited organosilicon thin films for the corrosion protection of metals" *Surface & Coating Technology*, Vol. 174-175, pp. 107-111, 2003..
- [10] F. Mansfeld, "Use of electrochemical impedance spectroscopy for the study of corrosion protection by polymer coatings", *J. Appl. Electrochem.*, vol. 25, no. 3, pp. 187-202, 1995.
- [11] P. L. Bonora, F. Deflorian, L. Fedrizzi, "Electrochemical impedance spectroscopy as a tool for investigating underpaint corrosion", *Electrochimica Acta*, vol. 41 no. 7-8, pp. 1073-1082, 1996.
- [12] M. E. Orazem, B. Tribollet *Electrochemical impedance spectroscopy* Wiley-Interscience, 2008
- [13] S. Corbellini, S. Grassini, M. Parvis, "Development and characterization of flexible electrodes for protective painting monitoring", International Instrumentation and Measurement Technology Conference Proceedings, I2MTC 2011, Hangzhou, pp. 1530-1535, 2011.
- [14] P.W. May et al., "Field emission from chemical vapor deposited diamond and diamond-like carbon films: Investigations of surface damage and conduction mechanisms", *Journal of Applied Physics*, vol. 84 no. 3, pp. 1618-1625, 1998.
- [15] Ansoft, *Simulation software for high-performance electronic design* available at www.ansoft.com/products.cfm
- [16] J. Monnier, et al. "A corrosion study of the ferrous medieval reinforcement of the Amiens Cathedral. Phase characterisation and localisation by various microprobes techniques." *Corrosion Science*, vol. 52, no. 3, pp. 695-710, 2010.



ities.

Simone Corbellini was born in Italy in 1977. He received his M.S. degree in Electronic Engineering in 2002 from the Politecnico di Torino, Italy, and his Ph.D. degree in metrology in 2006 from Politecnico di Torino, Italy. His main fields of interest are digital signal processing, distributed measurement systems, and intelligent microcontroller-based instrumentation. At present, he is working on the development of low-power wireless sensor networks for environmental, biomedical and chemical quantities.



the cultural heritage.

Sabrina Grassini was born in Italy in 1972. She received her M.S. degree in Chemistry in 1999 from the Università di Torino, Italy, and her Ph.D. degree in metallurgical engineering in 2004 from Politecnico di Torino, Italy. Currently she is an assistant professor in Chemistry with the Dipartimento di Scienza dei Materiali e Ingegneria Chimica, Politecnico di Torino. Her researcher areas include plasma chemistry and coating deposition, corrosion and protection of metallic materials, and conservation of



the cultural heritage.

Marco Parvis was born in Italy in 1958. He received his MS degree in electrical engineering in 1982 from the Politecnico di Torino, Italy, and a Ph.D. degree in Metrology in 1987. He is now full professor of Electronic Measurements at the Politecnico di Torino. He is Past Dean of the Second Faculty of Engineering of the Politecnico di Torino and Fellow Member and chair of the TC 25 Medical Measurement of the IEEE Society on Instrumentation and Measurement. His main fields of interest are: intelligent instrumentation, application of signal processing to measurement, biomedical and chemical measurements. He is author of more than one hundred publications.