



POLITECNICO DI TORINO
Repository ISTITUZIONALE

Comparison of Different Modulation Formats for 1-Gb/s SI-POF Transmission Systems

Original

Comparison of Different Modulation Formats for 1-Gb/s SI-POF Transmission Systems / Zeolla D. ; Nespola A. ; Gaudino R. . - In: IEEE PHOTONICS TECHNOLOGY LETTERS. - ISSN 1041-1135. - STAMPA. - 23:14(2011), pp. 950-952. [10.1109/LPT.2011.2143401]

Availability:

This version is available at: 11583/2491296 since:

Publisher:

IEEE

Published

DOI:10.1109/LPT.2011.2143401

Terms of use:

openAccess

This article is made available under terms and conditions as specified in the corresponding bibliographic description in the repository

Publisher copyright

(Article begins on next page)

Comparison of Different Modulation Formats for 1 Gigabit/s SI-POF Transmission Systems

D. Zeolla, A. Nespola and R. Gaudino, *Senior Member, IEEE*

Abstract— In the framework of the currently ongoing effort to find the best transmission solution for Gigabit Ethernet over Step-Index Polymer Optical Fiber (SI-POF), we give a novel contribution through the comparison of three possible modulation formats: Pulse Amplitude Modulation (PAM)-2, PAM-4 and duobinary, all coupled with electronic equalization at the receiver. We show that on a 50 meters SI-POF link using Resonant Cavity Light Emitting Diode (RC-LED), duobinary gives the best performance, followed by PAM-2 and then by PAM-4. All evaluations were performed by off-line processing experiments.

Index Terms—duobinary, FFE, home networking, quantization, SI-POF transmission systems

I. INTRODUCTION

Large core POF have gained interest as a possible medium for home and industrial networking [1]. In this scenario, the use of SI-POF (IEC A4a.2) and LED or RC-LED transmitters is usually perceived as a plus, since these systems are potentially very low cost. As of today (2011), some Telecom operators in Europe are offering POF kits running at 100Mbit/s for installation inside the house, over a target distance of at least 50 meters. The “next generation” POF systems must thus focus on upgrade to 1 Gigabit/s. Due to the bandwidth limitation of the link [2], it has already been shown that a proper combination of modulation formats and/or electronic equalization is required. Objective of this letter is to present our results regarding the behavior of different modulation formats over the channel of interest, consisting on a RC-LED-based optical transmitter, 50 meters of A4a.2 SI-POF and a large area photodiode. This link will be indicated as the “POF channel” in the following. We focus on three modulations: PAM-2 (i.e., traditional binary On-Off), PAM-4 and duobinary (a special class of partial response coding [3, Ch. 9]), all coupled with adaptive electronic equalization at the receiver. We investigate their performance, demonstrating that duobinary gives the best performance without any significant increase in implementation complexity. We believe that this paper is the first one that investigates the use of duobinary over POF. The analysis of other modulation formats, and in

Manuscript submitted on 2011, February 8th. This work was supported by EU STREP POF-PLUS, FP7, under Grant Agreement No. 224521. All authors are with “Istituto Superiore Mario Boella”, Via P. C. Boggio 61, 10138 Torino, Italy (corresponding author phone: +39-011-2276308, fax: +39-011-2276-299, e-mail: nespola@ismb.it), except R. Gaudino who is with Politecnico di Torino, Dipartimento di Elettronica, Corso Duca degli Abruzzi, 24, 10129 Torino, Italy (e-mail: Gaudino@polito.it)

particular of Orthogonal Frequency Division Multiplexing/Discrete Multi-tone Modulation (OFDM/DMT), can be found in other papers, such as [4].

II. EXPERIMENTAL SYSTEM SETUP

All our experiments are based on the off-line processing. The setup is shown in Figure 1. The line bit-rate is set to 1.1Gbps, according to the Physical Coding Sub-layer (PCS) described in [5], capable of transporting a 1 Gbps net data rate required by Gigabit Ethernet. The mapping of the PCS output bits to the transmitted signal is obvious for PAM-2, while for PAM-4, each couple of consecutive bits is mapped on 4 levels using a Gray labeling. For duobinary, we use the two different schemes shown in Fig. 2. In the first scheme, indicated in the rest of this paper as “DUO-3” (upper part of Fig. 2) we use a standard duobinary approach [3, Ch. 9] where the input logical stream is first pre-encoded by a proper logical circuit, then encoded to three-levels by a structure that is essentially a Finite Impulse Response (FIR) filter with two taps (both equal to +1, thus actually performing a low-pass filtering). The resulting signal sent to the RC-LED driver has the typical duobinary structure with a three level eye diagram. In the second scheme (“DUO-2”) we use only the pre-encoder, thus generating a two level signal. In terms of transmitted eye diagram, DUO-2 is thus identical to PAM-2. When in the operating mode DUO-2, the duobinary encoding function, corresponding to a proper low-pass filter is “implicitly” left to the POF channel, as explained also in [6]. For all four systems (PAM-2, PAM-4, DUO-3 and DUO-2), the signal sent to the RC-LED driver has the same (electrical) peak-to-peak swing $[-V_{peak}, +V_{peak}]$ (then a proper bias voltage is applied to the LED instantaneous current), so that the RC-LED optical instantaneous output power swing is exactly the same for all systems, thus allowing to compare the

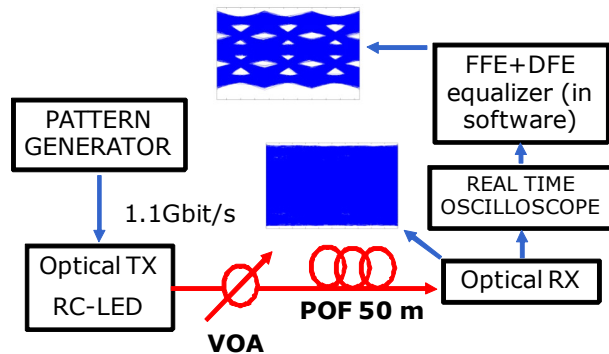

Fig. 1. Experimental setup plus eyediagrams before and after equalization.

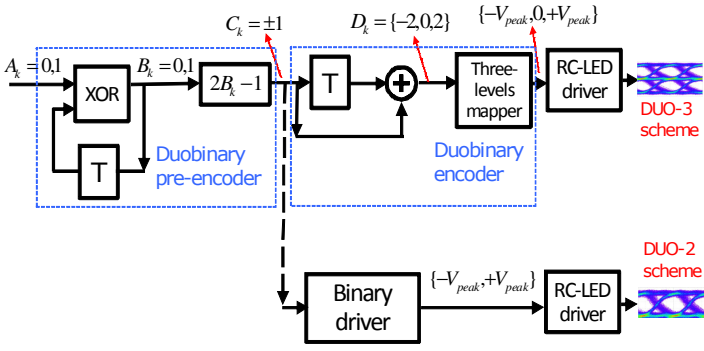

Fig. 2. Block diagrams for the DUO-3 and DUO-2 systems.

relative performance on a fair basis.

Regarding optoelectronics, we use a red RC-LED device from Firecomms driven by an optimized circuit [7] that generates well open optical eye diagrams (see small insets on the right side of Fig. 2) for the reference line rate of 1.1 Gbps. The average launched power into the fiber is -1.5dBm and the nominal central wavelength is equal to 650nm . The fiber utilized has an attenuation of 0.16dB/m , so that the average optical power at the output of the 50 meter POF link is -9.5dBm when the variable optical attenuator (VOA, see Fig. 1) is not used. The opto-electrical conversion is obtained by means of a commercial receiver that integrates a silicon pin photodiode and a transimpedance amplifier (model SPD-2 provided by Graviton Inc. [8]). The resulting signal at the output of the receiver module (shown in the inset of Fig.1) is first filtered by an anti-aliasing filter with a frequency response suitable to the power spectral density of the used modulation format, then collected by a real-time oscilloscope (acting as a Analog to Digital Converter, ADC, running at 5Gsample/s and 8 bits of quantization for the vertical scale) and then off-line processed in Matlab (down-sampling it to 2 samples per symbol, corresponding to 2.2GSample/s , the rate at which all the subsequent digital signal processing is performed). The time window recorded by the oscilloscope corresponds approximately to 250Kbits at 1.1Gbps , thus allowing a precise estimation of the Bit Error Rate (BER) by error counting for values down to 10^{-5} . For lower BER, we resort to a Gaussian approximation based on the mean and variance of the equalized signal at the sampling instant. We verified that this Gaussian approximation is in excellent agreement with the exact error counting technique by comparing the Gaussian results with the BER values obtained by direct error counting for values higher than 10^{-5} , obtaining the graph shown in Fig.3.

III. EXPERIMENTAL RESULTS

We start by analyzing the four modulation formats (PAM-2, PAM-4, DUO-3 and DUO-2) in terms of sensitivity at the output of a 50m link. In all cases, the eye diagrams are completely closed at the output of the POF channel due to the limited bandwidth available, that is in the order of 100MHz (-3dB electrical-to-electrical frequency cut-off). We thus used an adaptive Feed-Forward Equalizer (FFE) whose taps were optimized using a decision-driven Least Mean Square Error (LMSE) algorithm [3, Ch. 11]. We find that 16 fractionally-

spaced taps (corresponding to an equalizer memory equal to 8 bits) are enough to achieve the best possible performance for all situations. A detailed investigation on the optimization of the number of taps for our channel can be found in [10]. Fig. 3 shows the results in terms of received optical power vs. BER when we used a Field Programmable Gate Array (FPGA) as traffic generator, and we collected the received signals with a real-time oscilloscope with 8 bits of quantization for the vertical scale. Due to POF connectors and VOA intrinsic tolerances, we have an uncertainty on the measure of power around 0.2dB . The PAM-4 system performs worst than the others, while PAM-2 and DUO-3 have almost similar performances, with an increase of power margin, at 10^{-4} (level

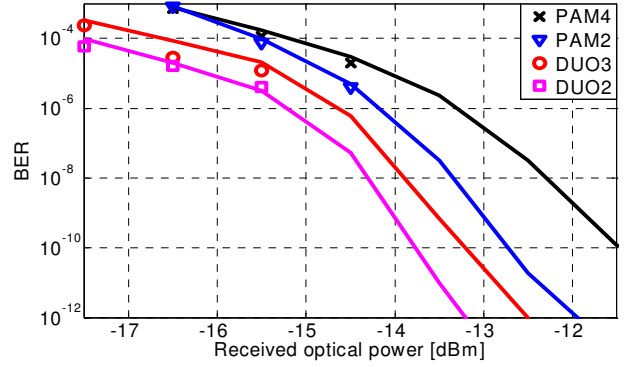

Fig. 3. BER vs. received optical power for PAM-2, PAM-4, DUO-3 and DUO-2. The receiver equalizer is based on a feed-forward structure with 16 taps for all cases. Solid lines represent Gaussian approximation, while markers show the error counting. The approximation is confirmed by error counting for BER values higher than 10^{-5} .

of interest for Forward Error Correction, FEC), of around 1dB of DUO-3 over PAM-2. The difference between theoretical results in [3, Ch. 5] and experimental ones (regarding PAM-2 and PAM-4) indicates that there are imperfections like nonlinearity and residual ISI in the experiment. The best performing format is DUO-2, with an additional increase of 1dB over DUO-3 (thus showing 2dB higher power margin at 10^{-4} than PAM-2). This is a very interesting result, since the complexity of DUO-2 is identical to PAM-2, including the fact that a Digital to Analog Converter (DAC) is not required at the transmitter side, since only a two level signal is transmitted. We checked also other transmitters and receivers with different sensitivities and different available bandwidths, and the resulting BER curves have the same relative performance among the four modulation formats as shown in Fig. 3. The obtained results are in line with the theoretical investigation carried out in [4] for what concerns PAM-2 and PAM-4, where it is shown that PAM-2 and a Decision Feedback Equalizer (DFE) is advantageous with respect to PAM-4 (and also to OFDM/DMT) till to a very strong bandwidth limitation, that is not reached in our system. Moreover, PAM-4 may have an additional penalty due to the (small, but non negligible) nonlinearity in the RC-LED driver. The advantage of duobinary formats over PAM-2 can be interpreted by remembering [3, Ch.9] that duobinary has a significant smaller bandwidth requirement. In our system, this allows the receiver equalizer to have a smaller emphasis on higher frequency components, and thus a smaller noise enhancement. Finally,

the better performance of DUO-2 compared to DUO-3 are likely due to the aforementioned nonlinearity in the RC-LED driver, and to the fact that in a peak-power limited system, such as the one under consideration, the DUO-2 signal (i.e., a pure binary signal) has the best possible crest factor parameter (see [4]).

We thus further investigate the performance in terms of the

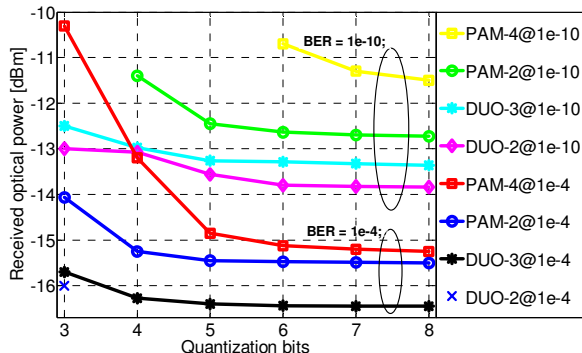

Fig. 4. Performance of the different modulation formats vs. the quantization bits in the receiver A/D converter in terms of required optical power for BER=10⁻⁴ and 10⁻¹⁰.

required number of quantization bits in the ADC, that is required for all system to counteract inter-symbol interference, showing the results in Fig 4. We see that PAM-4 requires at least 5 quantization bits to achieve its optimal performance, while for PAM-2 and even more for the DUO-3 and DUO-2 modulation formats the requirements on the ADC quantization bit are less stringent. In fact in these cases, even when using only 4 quantization bits, the power penalty is lower than 1dB compared to the use of 8 quantization bits (which was the situation used in Fig. 3). Considering that PAM-4 and DUO-3 have a higher transmitter complexity (since they both require the generation of a multilevel signal) and since this added complexity is not balanced by better transmission performance as shown in Fig. 3 and 4, we focalize our attention on PAM-2 and DUO-2. Both modulation formats have a very similar complexity at the Digital Signal Processing (DSP) level and require only binary signals at the transmitter side. We thus repeated the measurements on PAM-2 and DUO-2 introducing three variations with respect to the system used for Fig. 3 and 4:

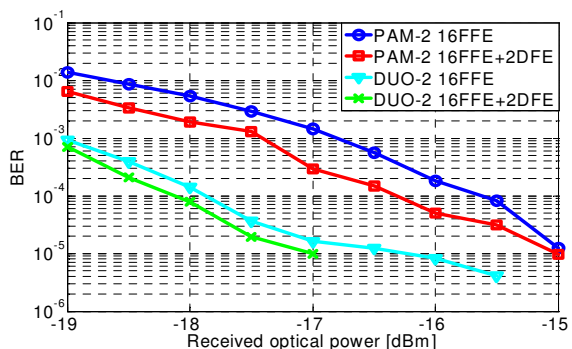

Fig. 5. BER vs. received optical power for DUO-2 and PAM-2 with feed-forward equalization and with decision-feedback equalization.

- we use a pattern generator at the transmitter, before the RC-LED, so that the binary signal applied to the RC-LED driver is almost ideal (very fast rising and falling

times), a condition that can be obtained by using a limiting amplifier in the LED driver;

- we focus on high BER (higher than 10⁻⁵), around the level of interest when FEC is used, so that direct error counting can be used;
- for both modulation formats, we also used a slightly more complex equalizer by adding also a feedback section with two taps.

The results are shown in Fig. 5: DUO-2 confirms its performance improvement over PAM-2 (even when a more complex DFE is used for PAM-2). We can see in fact from Fig. 5 that, when the same feed-forward equalizer is used, the increment of power margin of DUO-2 with respect to PAM-2 at 10⁻⁴ is around 2.3dB. Considering instead PAM-2 plus DFE, the increment of power margin at 10⁻⁴ is anyway more than 1.5dB in favor of DUO-2. The use of two taps of feedback with DUO-2 [9, Ch. 3] gives another little performance improvement with respect to the same modulation format using feed-forward only, evaluable in the order of 0.3dB, and in the order of 1.9dB comparing the same equalizer (feed-forward plus feedback) for PAM-2 and DUO-2.

IV. COMMENTS AND CONCLUSIONS

The experimental results shown in this paper demonstrated that duobinary coding is an attractive solution to increase the optical power margin in our SI-POF transmission system. In particular, we demonstrated that DUO-2 gives a 2.3dB advantage at BER=10⁻⁴ over PAM-2 for the same equalizer structure, with no relevant increase in hardware complexity.

REFERENCES

- [1] O. Ziemann, J. Krauser, P. Zamzow, and W. Daum, *POF Handbook: Optical Short Range Transmission Systems*, 2nd ed. New York: Springer, 2008.
- [2] A. Nespola, S. Abrate, R. Gaudino, C. Zerna, B. Offenbeck, and N. Weber, "High-speed communications over polymer optical fibers for in-building cabling and home networking," *IEEE Photon. J.*, vol. 2, no. 3, pp. 347-358, Jun. 2010.
- [3] J. G. Proakis "Digital Communications", McGraw-Hill, Fifth edition, 2008.
- [4] Randel, S., Breyer, F., Lee, S.C.J., Walewski, J.W., "Advanced Modulation Schemes for Short-Range Optical Communications," *IEEE Journal of Selected Topics in Quantum Electronics*, vol.16, no.5, pp.1280-1289, Sept.-Oct. 2010.
- [5] A. Nespola *et al.*, "A new physical layer capable of record gigabit transmission over 1mm step-index polymer optical fiber," *J. Lightw. Technol.*, vol. 28, no. 20, pp. 2944-2950, Oct. 2010.
- [6] Yoneyama M., Yonegaga K, Kisaka Y and Miyamoto Y., "Differential Precoder IC Modules for 20 and 40-Gbit/s Optical Duobinary Transmission Systems," *IEEE Transactions on Microwave Theory and Techniques*, vol. 47, no. 12, pp. 2263-2270, Dec. 1999.
- [7] B. Offenbeck, C. Zerna, N. Weber, A. Nespola, R. Gaudino, J. Lambkin, "Results of Gigabit/s transmission using RC-LEDs and new driving techniques", 18th International Conference on Plastic Optical Fibres, Sydney, 9-11 September 2009.
- [8] Graviton Optoelectronic Catalog and Specification, see <http://www.graviton.co.jp>
- [9] J. Cioffi "Digital Communications", book available online: see <http://users.ece.utexas.edu/~jandrews/ee381k2/reader.html>
- [10] D. Zeolla, A. Antonino, G. Bosco, R. Gaudino, "DFE vs. MLSE Electronic Equalization for Gigabit/s SI-POF Transmission Systems", accepted for publications on *IEEE Photonic Technology Letters*