

Risonatore cilindrico a microonde

*Original*

Risonatore cilindrico a microonde / DE MARCHI, Andrea. - (2009).

*Availability:*

This version is available at: 11583/2375102 since:

*Publisher:*

*Published*

DOI:

*Terms of use:*

This article is made available under terms and conditions as specified in the corresponding bibliographic description in the repository

*Publisher copyright*

(Article begins on next page)

Domanda di Brevetto Internazionale

N°: PCT/IB2009/054311

depositata il: 02 Ottobre 2009

a nome: POLITECNICO DI TORINO

Stati designati: ALBANIA - ALGERIA - ANGOLA - ANTIGUA E BARBUDA - ARMENIA - AUSTRALIA - AUSTRIA - AZERBAIJAN - BAHRAIN - BARBADOS - BELIZE - BIELORUSSIA - BOSNIA/ERZEGOVINA - BOTSWANA - BRASILE - BULGARIA - CANADA - CILE - CINA - COLOMBIA - COSTA RICA - CROAZIA - CUBA - DANIMARCA - DOMINICA - ECUADOR - EGITTO - EL SALVADOR - EMIRATI ARABI - ESTONIA - FED. RUSSA - FILIPPINE - FINLANDIA - GAMBIA - GEORGIA - GERMANIA - GHANA - GIAPPONE - GRAN BRETAGNA - GRENADA - GUATEMALA - HONDURAS - INDIA - INDONESIA - ISLANDA - ISOLE COMORE - ISRAELE - KAZAKSTAN - KENYA - KIRGHISIA - LAOS - LESOTHO - LIBERIA - LIBIA - LITUANIA - LUSSEMBURGO - MADAGASCAR - MALAWI - MALAYSIA - MAROCCO - MESSICO - MONGOLIA - MONTENEGRO - MOZAMBICO - NAMIBIA - NICARAGUA - NIGERIA - NORVEGIA - NUOVA ZELANDA - OMAN - PAPUA NUOVA GUINEA - PERU' - POLONIA - PORTOGALLO - REP. CECA - REP. DEM. DI COREA - REP. DI COREA - REP. DOMINICANA - REP. DI MACEDONIA - REP. DI MOLDAVIA - ROMANIA - SAINT KITTS AND NEVIS - SAINT LUCIA - SAINT VINCENT E GRENADINES - SAN MARINO - SÃO TOMÉ E PRÍNCIPE - SEYCHELLES - SERBIA - SIERRA LEONE - SINGAPORE - SIRIA - SLOVACCHIA - SPAGNA - SRI LANKA - SUD AFRICA - SUDAN - SVEZIA - SVIZZERA/LIECHTENSTEIN - TAJIKISTAN - TANZANIA - TRINIDAD E TOBAGO - TUNISIA - TURCHIA - TURKMENISTAN - UCRAINA - UGANDA - UNGHERIA - U.S.A. - UZBEKISTAN - VIETNAM - ZAMBIA - ZIMBABWE

- BREVETTO EUROPEO (comprendente: Austria, Belgio, Bulgaria, Cipro, Croazia, Danimarca, Estonia, Finlandia, Francia, Germania, Gran Bretagna, Grecia, Irlanda, Islanda, Italia, Lettonia, Lituania, Lussemburgo, Macedonia, Malta, Norvegia, Paesi Bassi, Polonia, Portogallo, Principato di Monaco, Rep. Ceca, Romania, San Marino, Slovacchia, Slovenia, Spagna, Svezia, Svizzera/Liechtenstein, Turchia, Ungheria e con estensione dei diritti a: Albania, Bosnia-Erzegovina, Serbia)

- OAPI (comprendente: Benin, Burkina Faso, Cameroon, Repubblica Centrale Africana, Chad, Congo, Costa d'Avorio, Gabon, Guinea, Guinea-Bissau, Guinea Equatoriale, Mali, Mauritania, Niger, Senegal, Togo)

- ARIPO (comprendente: Botswana, Gambia, Ghana, Kenya, Lesotho, Malawi, Mozambico, Namibia, Sierra Leone, Sudan, Swaziland, Tanzania, Uganda, Zambia, Zimbabwe)

- BREVETTO EUROASIATICO (comprendente: Armenia, Azerbaijan, Bielorussia, Fed. Russa, Kazakistan, Kirghisia, Rep. di Moldavia, Tajikistan, Turkmenistan)



### Receipt of Electronic Submission

It is hereby acknowledged that a PCT International Application has been received via the Secure Electronic Submission Software of the IB. Upon receipt, Application Number and a Date of Receipt (Administrative Instructions, Part 7) has been automatically assigned.

Submission Number:	28506		
Application Number:	PCT/IB2009/054311		
Date of Receipt:	02 October 2009		
Receiving Office:	International Bureau of the World Intellectual Property Organization		
Your Reference:	PC937GQ		
Applicant:	POLITECNICO DI TORINO		
Number of Applicants:	2		
Title:	A CYLINDRICAL MICROWAVE RESONATOR		
Documents Submitted:	PC937GQ-appb-P000001.pdf	701721	01 October 2009 14:42:06
	PC937GQ-fees.xml	2299	02 October 2009 09:30:44
	PC937GQ-othd-000002.pdf	156420	01 October 2009 14:45:04
	PC937GQ-vlog.xml	3940	02 October 2009 09:30:44
	PC937GQ-othd-000001.pdf	681613	01 October 2009 14:44:20
	PC937GQ-decl.xml	1617	02 October 2009 09:30:44
	PC937GQ-requ.xml	7638	02 October 2009 09:35:58
	PC937GQ-abst.txt	2	02 October 2009 09:30:44
	PCT101.GML	2925	02 October 2009 10:22:13
	PC937GQ-appb.xml	902	02 October 2009 09:30:44
Signed by:	EMail=pat1torino@jacobacci.com, CN=giuseppe quinterno, OU=www.verisign.com/repository/CPS Incorp. by Ref.,LIAB.LTD(c)99, OU=WIPO Customer CA, O=World Intellectual Property Organization		
Timestamp of Receipt:	02 October 2009 10:21		
Official Digest of Submission:	5B:39:84:DD:CB:67:C6:09:C5:9B:AA:5F:3D:56:72:47:57:EC:AD:14		

/Geneva, RO/IB/

## A cylindrical microwave resonator

The present invention relates in general to microwave resonators, in particular for the manufacture of oscillators.

More specifically the invention relates to a cylindrical microwave resonator, of the type comprising:

a cylindrical tubular member made of metal material, and

closure means likewise made of metal material and associated with the tubular member so as to define in the inside thereof a cylindrical cavity resonating at a predetermined frequency;

and in which said closure means have a thermal elongation coefficient different from that of the tubular member so as to reduce the variation in the resonance frequency of the cavity upon variation of the temperature.

A microwave resonator of this type is described for example in "A Novel Configuration for Microwave Resonator with Zero Temperature-Coefficient", by M. Long, A. S. Gupta, F. L. Walls, Frequency Control Symposium 2007 joint with the 21st European Frequency and Time Forum, IEEE International, May 29-June 1 2007, pages 1020-1022.

A cylindrical microwave resonator of the type described in this document is schematically shown in Figure 1 of the accompanying drawings, where it is denoted overall by 1. This resonator comprises a cylindrical tubular member 2, for example made of molybdenum with a silver-coated inner surface, and a pair of closing caps 3, for example made of silver aluminium. These caps each have a respective cylindrical shank 3a which extends inside a respective end of the tubular member 2 so as to define together therewith a cylindrical cavity 5, having a length  $l$  and diameter  $D$ , resonating at a predetermined frequency. The closing caps 3 are identical to each other and their shanks have a thermal elongation coefficient different from that of the tubular member 2 so as to reduce the variation  $\Delta\nu$  in the resonance frequency  $\nu$  of the cavity 5 upon variation of the temperature  $T$ .

Upon variation of the temperature  $T$  by an amount  $\Delta T$ , the length  $l$  of the cavity 5 varies

correspondingly by an amount  $\Delta l$ , as expressed by the equation:

$$\Delta l/l = \alpha (\Delta T) + \beta (\Delta T)^2 + \gamma (\Delta T)^3 + \dots \quad (1)$$

where  $\alpha$ ,  $\beta$ ,  $\gamma$ , ... are the thermal elongation coefficients of the first order, second order, third order, etc.

A variation in the length  $l$  of the cavity 5, caused by a variation of the temperature  $T$ , in turn causes a variation in the frequency  $\nu$ . With the solution proposed in the abovementioned prior publication it is possible to offset or compensate in part for this variation in the frequency.

However, there is a considerable discrepancy between theory and experimental verification of the solution described in this publication so that the effective improvement in the frequency stability which can be achieved in practice is markedly less than that which is theoretically possible.

One object of the present invention is to propose a cylindrical microwave resonator of the type specified above, which is able to achieve a better frequency stability compared to the known solution described above.

This and other objects are achieved according to the invention with a cylindrical microwave resonator of the type defined initially, characterized in that the abovementioned closure means comprise at least two cap portions made of different metal materials, having respective thermal elongation coefficients of the first and second order and respective axial lengths such as to compensate at least in part for the thermal elongation coefficients of the first and second order of the tubular member.

Further characteristic features and advantages of the invention will become clear from the following detailed description provided purely by way of a non-limiting example, with reference to the accompanying drawings in which:

Figure 1, already described, shows the structure of a cylindrical microwave resonator according to the prior art;

Figure 2 shows the variation in frequency upon variation of the temperature in a

resonator according to the prior art of the type shown in Figure 1;

Figure 3 is a view, partially sectioned axially, of a cylindrical microwave resonator according to the present invention;

Figures 4 and 5 are graphs which show the variation in frequency as a function of the variation of the temperature in a resonator according to the present invention; and

Figures 6 to 8 are partially sectioned views of three further embodiments of resonators according to the invention.

The present invention is based essentially on recognition of the fact that the authors of the aforementioned prior publication have essentially overlooked the effect of the quadratic term in the above equation (1), namely they have assumed  $\beta = \gamma = 0$ . According to this assumption, in the case of a resonator having the structure shown in Figure 1, the relative variation in the frequency upon variation of the temperature is essentially expressed by the following equation:

$$\Delta v/v = k \alpha_D^2 (\Delta T)^2 \quad (2),$$

where k is a constant.

As a result of this assumption, the theory expounded in the aforementioned publication leads one to assume that the progression of the variation in frequency  $\Delta v$  as a function of the variation in temperature  $\Delta T$  has an essentially parabolic progression, as shown by the curved indicated by A in the graph of Figure 2.

In reality, if in the equation (1) the quadratic term is not negligible, the following expression is obtained for the variation in frequency  $\Delta v/v$ :

$$\Delta v/v = k \alpha_D^2 (\Delta T)^2 + (\beta_c - \beta_D) \left( \frac{\alpha_D}{\alpha_c - \alpha_D} - \frac{\beta_D}{\beta_c - \beta_D} \right) (\Delta T)^2 \quad (3)$$

where  $\alpha_C$  and  $\alpha_D$  are the elongation coefficients of the first order of the shanks 3a and caps 3 and of the tubular member 2, respectively, and  $\beta_C$  and  $\beta_D$  are the thermal elongation coefficients of the second order thereof.

An examination of the equation (3) shows how, depending on the materials used, and therefore their thermal elongation coefficients, the variation in the frequency upon

variation of the temperature may be very much greater than that which can be predicted using the equation (2) and may assume, for example, the progression of the parabola - indicated by B in Figure 2 - which is much "narrower" than that indicated by A.

On the other hand, the equation (3) shows that a suitable selection of the materials may result in the zeroing or even a negative value of the second term in this equation. The present invention arises from this observation, namely that it is possible to ensure that the second term in the equation (3) reduces substantially the  $\Delta v/v$  and even zeroes it completely or nearly so.

Based on the aforementioned observation, the invention consists essentially in having recognized that it is possible to "synthesize" or determine the thermal behaviour of the closing caps of the resonator in such a way as to improve substantially the stability of the frequency upon variation of the temperature, compared to the prior art solution described above.

Figure 3 shows a first embodiment of a microwave resonator according to the invention. In this figure parts and elements already described have been assigned again the same reference numbers and/or letters.

In the solution according to Figure 3, the resonator 1 comprises two end caps 3, which are identical to each other, with respective cylindrical shanks 3a which each have a first and a second axial portion c1 e c2, adjacent to one another, made with different metal materials, having respective thermal elongation coefficients of the first order and second order  $\alpha_{c1}$ ,  $\beta_{c1}$  and  $\alpha_{c2}$ ,  $\beta_{c2}$  and respective axial lengths  $l_{c1}/2$  and  $l_{c2}/2$  such as to compensate at least in part for the thermal elongation coefficients of the first and second orders  $\alpha_D$ ,  $\beta_D$  of the tubular member 2.

With reference to Figure 3, the tubular member 2 may be made for example with tungsten, preferably containing a percentage of nickel and iron, for example about 2% by weight of nickel and 1% by weight of iron. Alternatively, the tubular member 2 could be made with molybdenum. In any case it is convenient for the inner surface of the tubular member 2 to

be silver-coated.

The portions c1 of the shanks 3a of the end caps 3 may be conveniently made using an austenitic steel, for example AISI 304, while the portions c2 may be made of copper.

By means of suitable selection of the materials of the portions c1 and c2 and precise definition of their axial lengths it is possible to ensure that the variation  $\Delta v$  as a function of the variation in temperature  $\Delta T$  assumes a progression in the manner of a cubic parabola, for example in accordance with the curve C shown in Figure 4, which corresponds to a condition where the thermal elongation coefficient of the second order  $\beta_D$  of the tubular member 2 has also been substantially compensated for. The improvement in terms of frequency stability is evident compared to the progression of the curve B which, as shown in Figure 2, represents the most "realistic" progression which can be achieved with the solution according to the prior art.

Figure 4 and Figure 5 show - the latter on a smaller scale - the progression of a curve D which can be obtained with compensation of the thermal elongation coefficient of the second order of the tubular member 2 in the case where  $\gamma = 0$  for all the metals used. If, instead, one takes into account the fact that the thermal elongation coefficients of the third order ( $\gamma$ ) are not zero, the curve obtained is that indicated by C in Figure 4.

The dimensions of the resonator according to Figure 3 may be determined substantially as described below.

The dimensions l and D of the cavity 5 are determined in a manner known per se on the basis of the desired resonance frequency.

The equation (3) may then be rewritten as follows:

$$\Delta v/v = 3/2(\lambda_g/\lambda_c)^2 \alpha_D^2 (\Delta T)^2 + (\beta_{cs} - \beta_D) \left( \frac{\alpha_D}{\alpha_{cs} - \alpha_D} - \frac{\beta_D}{\beta_{cs} - \beta_D} \right) (\Delta T)^2 \quad (4)$$

where  $\lambda_g = 2l/3$ ,

$\lambda_c = \pi D/\chi$ , with for example  $\chi = 7.016$  if the TE023 mode resonates in the

cavity, and

$\alpha_{cs}$  is the overall thermal elongation coefficient of the first order for the shanks 3a of the end caps of the resonator, and  $\beta_{cs}$  is the overall thermal elongation coefficient of the second order for said shanks 3a.

In the equation (4)  $\alpha_D$  e  $\beta_D$  are the thermal elongation coefficients of the first and second order of the tubular member 2.

From the equation (4), in order to obtain  $\Delta v = 0$  the following is necessary:

$$\frac{\beta_{cs}}{\alpha_{cs}} < \frac{\beta_D}{\alpha_D}, \text{ with } \beta_{cs} > \beta_D.$$

Once the materials for the tubular member 2 and the caps 3 - for example the materials mentioned above - have been chosen, it is then merely required to determine the coefficients  $\alpha_{c1}$ ,  $\beta_{c1}$  and  $\alpha_{c2}$ ,  $\beta_{c2}$  of the portions c1 and c2 of the end caps as well as the associated lengths  $l_{c1}$  and  $l_{c2}$  in the equation (4).

The values of these lengths may be easily determined on the basis of the following system of equations:

$$3/2(\lambda_g / \lambda_c)^2 \alpha_D^2 + (\beta_{cs} - \beta_D) \left( \frac{\alpha_D}{\alpha_{cs} - \alpha_D} - \frac{\beta_D}{\beta_{cs} - \beta_D} \right) = 0 \quad (5)$$

$$z = z_1 + z_2 = (l_{c1} + l_{c2}) / l \quad (6)$$

$$(1 + z)\alpha_D - z\alpha_{cs} = 0 \quad (7)$$

$$z\alpha_{cs} = z_1\alpha_{c1} + z_2\alpha_{c2} \quad (8)$$

$$z\beta_{cs} = z_1\beta_{c1} + z_2\beta_{c2} \quad (9)$$

The equation (5) shown above expresses the condition for zeroing the variation in frequency upon variation of the temperature, while the following equations express the relations existing between the thermal elongation coefficients and the lengths of the portions c1 and c2 of the end caps of the resonator.

Figures 6 to 8 show alternative embodiments of a resonator according to the present

invention.

In the variant according to Figure 6, the resonator comprises a tubular member 2 which is closed at one end by a cap 3 similar to those described above with reference to Figure 3. The other end of the tubular member 2 is closed by a wall 2a made with a material which has substantially the same thermal elongation as this tubular member. The end wall 2a may be integral with the tubular member or made separately and joined to this tubular member in one of the various ways known per se.

In the case of the solution according to Figure 6, the dimensions are determined substantially in the same way as described above for the variant according to Figure 3, with the lengths  $l_{c1}$  and  $l_{c2}$  which represent the lengths of the portions c1 and c2 of the shank of the cap 3, as shown in Figure 6 itself.

In the variant according to Figure 7, the resonator 1 comprises two end caps 3 and 4, the shanks 3a and 4a of which are each made using a single material. The materials of these shanks, however, have thermal elongation characteristics which are different from one another. The dimensions in this case are determined substantially in the manner described above, where the lengths  $l_{c1}$  and  $l_{c2}$  represent the respective lengths of the two shanks 3a and 4a.

Finally, Figure 8 shows an embodiment in which the resonator 1 has an end cap 3 which is similar to the caps of the version according to Figure 3 or the version according to Figure 6 and therefore is formed with two axial portions c1, c2 made of materials having different thermal elongation characteristics. The resonator 1 according to Figure 8 has a further end cap 4, the shank of which, with a length  $l_{c3}$ , is made with a material having thermal elongation characteristics different from those of the portions c1 and c2 of the cap 3.

With the solution comprising three materials (c1, c2, c3) according to Figure 8 it is possible to compensate also for thermal elongation coefficient of the third order  $\gamma$  of the tubular member 2.

Obviously, without affecting the principle of the invention, the embodiments and the

constructional details may be greatly modified with respect to that described and illustrated purely by way of a non-limiting example, without thereby departing from the scope of the invention as defined in the accompanying claims.

CLAIMS

1. Cylindrical microwave resonator (1), comprising  
a cylindrical tubular member (2) made of metal material, and  
closure means (3; 3, 4), likewise made of metal material, associated with the tubular member (2) so as to define in the inside thereof a cylindrical cavity (5) resonating at a predetermined frequency;  
said closure means (3; 3, 4) having a thermal expansion coefficient different from that of the tubular member (2), so as to reduce the variation in the resonance frequency ( $\nu$ ) of the cavity (5) upon variation of the temperature (T);  
the resonator (1) being characterized in that said closure means (3; 3, 4) comprise at least two cap portions (c1, c2) made of different metal materials, having respective thermal elongation coefficients of the first and the second order ( $\alpha_1, \beta_1; \alpha_2, \beta_2$ ) different from each other, and respective axial lengths ( $l_{c1}, l_{c2}$ ), such as to compensate at least in part for the thermal elongation coefficients of the first and second order ( $\alpha_D, \beta_D$ ) of the tubular member (2).
2. Microwave resonator according to Claim 1, in which the closure members comprise at least one cap (3) having a cylindrical shank (3a) which extends inside one end of the tubular member (2) and has a first and a second axial portion (c1, c2) adjacent to one another, made with different metal materials having respective thermal elongation coefficients of the first and the second order ( $\alpha_1, \beta_1; \alpha_2, \beta_2$ ) different from one another, and respective axial lengths ( $l_{c1}, l_{c2}$ ), such as to compensate at least in part for the thermal elongation coefficients of the first and the second order ( $\alpha_D, \beta_D$ ) of the tubular member (2).
3. Microwave resonator according to Claim 2, in which the closure means comprise two caps (3, 4) as defined above, each having a respective cylindrical shank (3a, 4a) which extends inside a respective end of the tubular member (2).
4. Microwave resonator according to Claim 1, in which the closure means comprise two caps (3, 4; see Figure 7) comprising respective cylindrical shanks (3a, 4a) extending each inside a respective end of the tubular member (2); said shanks (3a, 4a) being made

each with a metal material different from that of the other one, said materials having respective thermal elongation coefficients of the first and the second order ( $\alpha_1, \beta_1; \alpha_2, \beta_2$ ) different from one another, and respective axial lengths ( $l_{c1}, l_{c2}$ ), such as to compensate at least in part for the thermal elongation coefficients of the first and the second order ( $\alpha_D, \beta_D$ ) of the tubular member (2).

5. Microwave resonator according to Claim 1, in which the closure means comprise at least three cap portions ( $c1, c2, c3$ ) having respective thermal elongation coefficients different from one another, and respective axial lengths, such as to compensate at least in part for the thermal elongation coefficients of the first, second and third order of the tubular member (2).

ABSTRACTA cylindrical microwave resonator

The microwave resonator (1) comprises a tubular member (2) made of metal material, and closing caps (3; 3, 4), likewise made of metal material, associated with the tubular member (2) so as to define in the inside thereof a cylindrical cavity (5) resonating at a predetermined frequency.

The closing caps (3; 3, 4) have a thermal expansion coefficient different from that of the tubular member (2) so as to reduce the variation in the resonance frequency ( $\nu$ ) of the cavity (5) upon variation of the temperature (T). These closing caps (3; 3, 4) comprise at least two portions (c1, c2) made of different metal materials, having respective thermal elongation coefficients of the first and second order ( $\alpha_1, \beta_1; \alpha_2, \beta_2$ ) different from one another, and respective axial lengths ( $l_{c1}, l_{c2}$ ), such as to compensate at least in part for the thermal elongation coefficients of the first and second order ( $\alpha_D, \beta_D$ ) of the tubular member (2).

(Figure 3)

**FIG. 1**  
(TECNICA ANTERIORE)

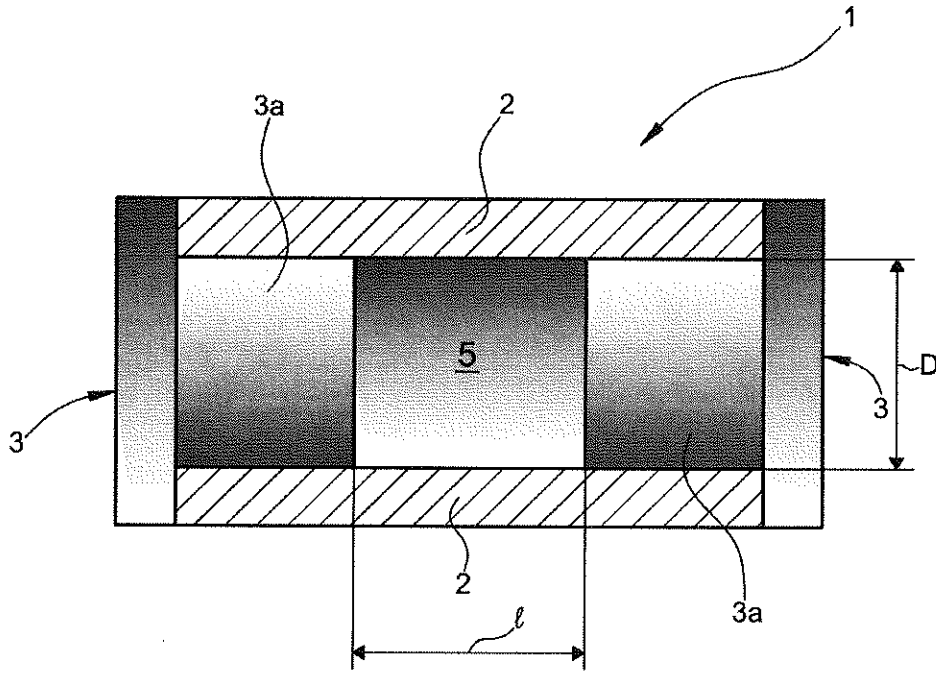

**FIG. 2**  
(TECNICA ANTERIORE)

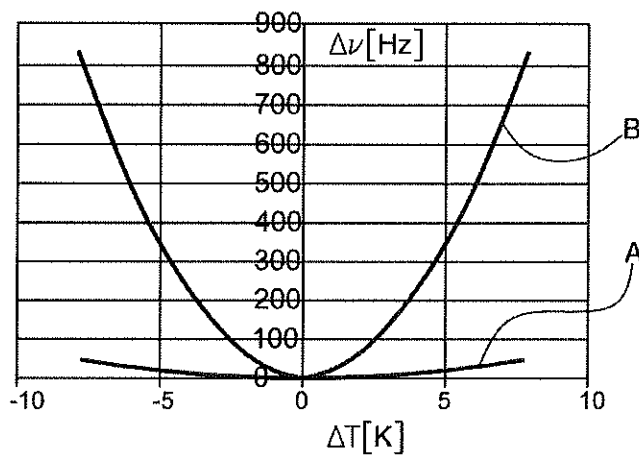

FIG. 3

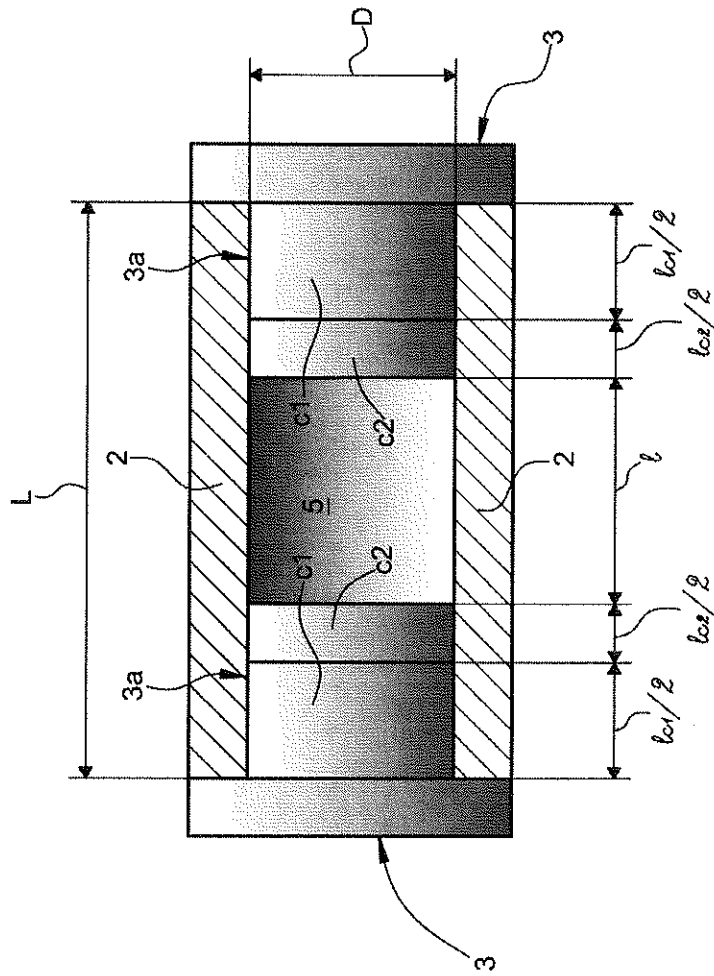

FIG. 4

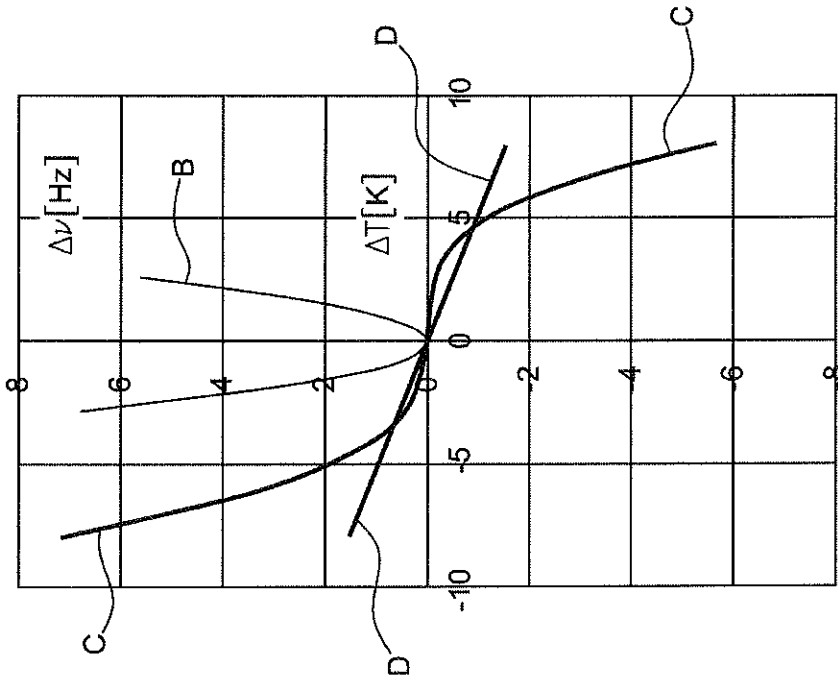

FIG. 5

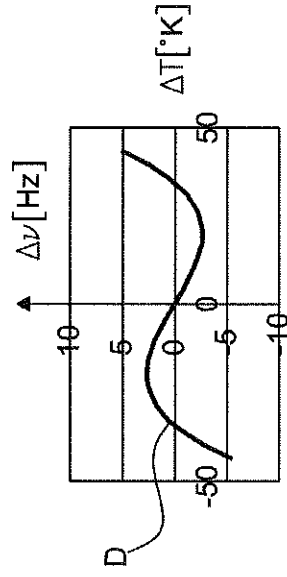

FIG. 6

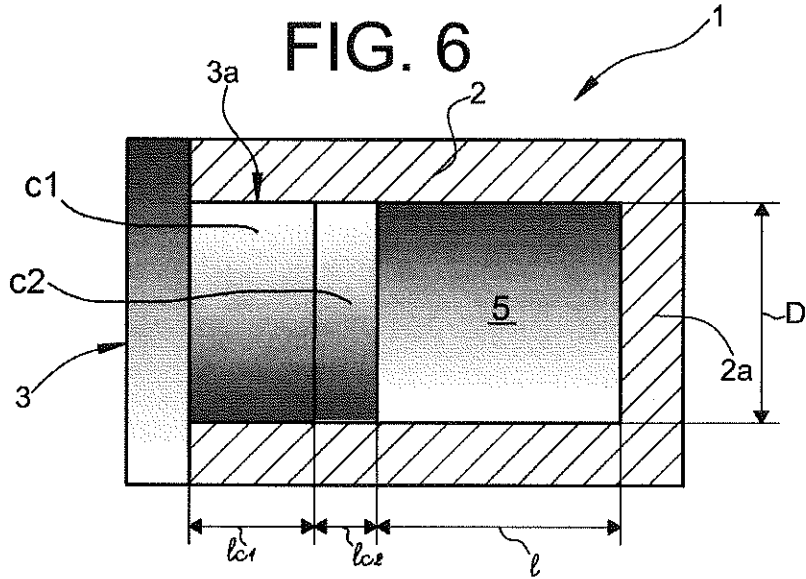

FIG. 7

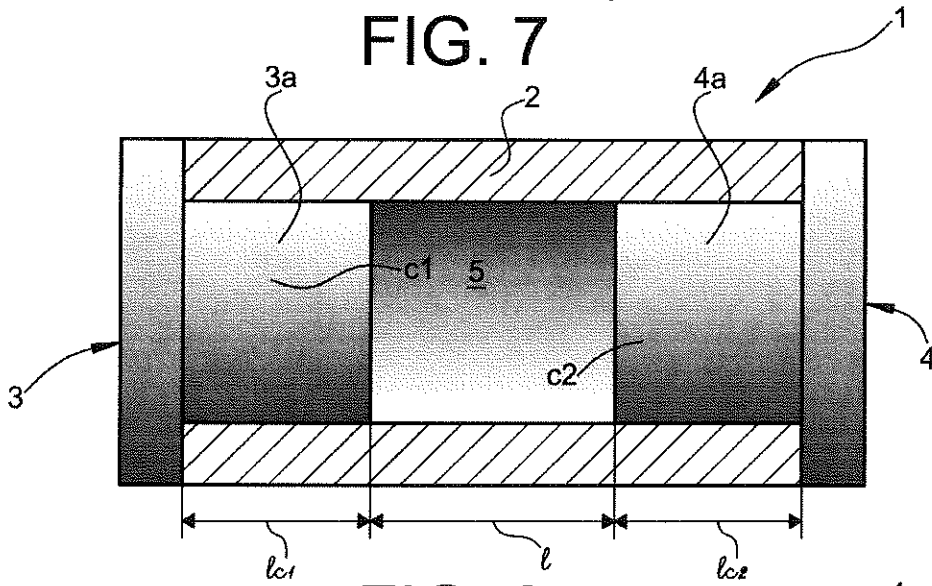

FIG. 8

