

Innovative Piloting Technique for a Semi-Autonomous UAV Lighter-Than-Air Platform Simulator

*Original*

Innovative Piloting Technique for a Semi-Autonomous UAV Lighter-Than-Air Platform Simulator / Battipede, Manuela; Vazzola, Matteo; Tancredi, D.. - ELETTRONICO. - (2009). (Intervento presentato al convegno AIAA Modeling and Simulation Technologies Conference tenutosi a Chicago, Illinois - USA nel August 10-13, 2009) [10.2514/6.2009-6229].

*Availability:*

This version is available at: 11583/2368635 since: 2017-05-26T16:49:44Z

*Publisher:*

AIAA

*Published*

DOI:10.2514/6.2009-6229

*Terms of use:*

This article is made available under terms and conditions as specified in the corresponding bibliographic description in the repository

*Publisher copyright*

(Article begins on next page)

# Innovative Piloting Technique for a Semi-Autonomous UAV Lighter-Than-Air Platform Simulator

M. Battipede\* M. Vazzola†  
*Politecnico di Torino – 10129 Torino, ITALY*

and

D. Tancredi‡  
*West Virginia University - Morgantown, WV 26506/6106, USA*

**UAS design has in these years reached a point in which trends and objectives are well beyond the actual test capabilities. The tendency of the past to build and test has clearly been overridden by new design concepts for many reasons, one of these being the scarce or null possibility of testing safety-critical systems such as UAV systems. This is the context in which the Elettra-Twin-Flyer (ETF) Simulator is constantly upgraded and rearranged to incorporate new features and more advanced capabilities. In this paper it is shown how the piloting modes have been differentiated, to improve the airship autonomy and allow path following operations. Innovative piloting tools have been introduced and a new Human-Machine-Interface has been proposed along.**

## I. Introduction

UAV systems have reached a level of complexity and completeness which makes them strongly competitive with regard to their corresponding piloted versions. However, in order for the UAVs to reach their full potentialities, significant technical issues must be overcome. Among the others, the most challenging aspect concerns command and control. In this context, the American DOD Roadmap<sup>1</sup> for UAVs has envisioned a ten-level scale of autonomy which sets the research trend for the next two decades. According to the American DOD, in fact, progress in technology should allow the UAV to pass from a dull remotely piloted version to a flying supercomputer, with human-like reconfigurable planning and strategic capabilities, which should synergically join other UAVs to form a completely autonomous, mission-oriented swarm. Transition from pilot-in-the-loop to autonomy is somehow a common trend, which is characterizing the UAV's evolution both in the military and civil applications, driven by different needs towards the same goal. The DOD, in fact, has the urgency of introducing persistent intelligence as well as very accurate and timely target-oriented instruments which are generally employed in the most aggressive battle scenarios. Performance and autonomy might seem less stringent requirements for civil applications, where UAVs are mainly employed in surveillance and reconnaissance missions. Nevertheless, even in the most standard non-critical operations a certain degree of autonomy is sought and pursued as a necessary measure to guarantee safety. The airworthiness authorities, in fact, have clearly stated that preliminary condition for UAV certification is the capability of accomplishing critical flight phases autonomously.

Transition from pilot-in-the-loop to autonomy<sup>2</sup> is hence a requisite and it is clear how it will affect the predominance on one technology over the other: the two different approaches to implementing unmanned flight, in fact, today rely predominantly on communication (data link) and microprocessor technology, respectively. If robust communication is a urgency today, the sense-and-avoid capability and the reliability-enhancing health monitoring will be the prerequisites for tomorrow. Technology has to evolve along with the UAV concept and all the other elements of the system must be conceived and adapted to fill the gap towards the ultimate goal of safe and satisfactory autonomous operation. The key to development is to design all subsystems as auxiliary tools and foresee rapid and drastic change

---

\*Assistant Professor, Aeronautical and Space Department, Corso Duca degli Abruzzi 24, AIAA Member

†Ph.D. Student, Aeronautical and Space Department, Corso Duca degli Abruzzi 24

‡Ph.D. Student, Department of Mechanical and Aerospace Engineering, Engineering Sciences Building, Evansdale Drive

of use for each of these elements. The ground station is included in this category, as the pilot itself, along with the Human-Machine-Interface, which still represents an open issue also for piloted aircrafts. They must be all shaped around the aerial segment and incorporate all the basic technologies, which are supposed to be transferred onboard in the next few years.

There is no other subject as UAV design and operation, however, in which the gap between trend and reality is so evident: civil UAVs, in fact, can hardly obtain permissions for short flights in restricted areas and for specific missions. The sceneries envisioned by industries and operators are yet futuristic and nevertheless they will be the state-of-the-art, as soon as airworthiness regulations are issued. Simulation is hence strategic to develop and test all the key elements around the aerial segments, as well as piloting strategies and operational procedures.

This is the context in which the Elettra-Twin-Flyer (ETF) Simulator is constantly updated and upgraded, dismembered and rearranged to incorporate new features and more advanced capabilities. In this paper it is shown how the piloting modes have been differentiated, to improve the airship autonomy and allow path following operations. Innovative piloting tools have been introduced and a new Human-Machine-Interface has been proposed along.

### I. Automatic vs. Autonomous

The main difference between automatic and autonomous aircraft operation lays in the way the task is executed. Automatic flight, in fact, is a well known technology in aeronautics and is actually being employed on civil and military aircrafts since many decades. Automatic operations usually involve flight phases such as landing or cruise of even just parts of them. They are performed by autopilots which are triggered directly by the pilot. The succession of commands is determined and performed without any form of optimization by the machine and still requires human intervention/supervision. Autonomy, on the contrary, is a new concept in aeronautics, even if it has been largely explored in aerospace. To perform autonomous operations, the aircraft exploits the onboard logic to analyze and identify the best solutions and decides the most appropriate sequence of commands to be executed. Autonomous flight clearly rely on a very high degree of optimization, which can be performed uniquely on data collected by the onboard sensors or on a miscellaneous of data which might be stored into the onboard computers, collected by the onboard sensors or sent from the Ground Station. The introduction of automatic operations in aeronautics has been encouraged mainly by safety reasons. It was estimated, for example, that prior to automatic landing systems there was a fatal accident risk of 1 in 106 landings. Other autopilots, such as the condition-hold control systems, are less strategic, but can be seen as means to relieve the pilot from the workload derived from excessive long and dull flight phases

Primary Modes	Levels	Operational Relationship	Computer Autonomy	Pilot Authority	Adaptation	Information on performance
AUTOMATIC		Automatic	Full	Interrupt	Computer monitored by pilot	On/off Failure warnings Performance only if required.
ASSISTED	4	Direct Support	Advised action unless revoked	Revoking action	Computer backed up by pilot	Feedback on action. Alerts and warnings on failure of action.
	3	In Support	Advice, and if authorised, action	Acceptance of advice and authorising action	Pilot backed up by the computer	Feed-forward advice and feedback on action. Alerts and warnings on failure of authorised action.
	2	Advisory	Advice	Acceptance of advice	Pilot assisted by computer	Feed-forward advice
	1	At Call	Advice only if requested.	Full	Pilot, assisted by computer only when requested.	Feed-forward advice, only on request
COMMANDED		Under Command	None	Full	Pilot	None performance is transparent.

Table 1 - Bonner Taylor framework for pilot authorization and task control

In the military aviation expectations are very high: indications have been given in the Roadmap issued by the U.S. Department of Defense which sees, in technological level reached by the electronics great possibility for a decisive increasing of decision power for the UAS within for the next two decades. According to the Roadmap, for example,

the automatic target recognition capability should be at a ripe status by the end of 2010 and the current literature shows that research has almost reached the desired target<sup>3</sup>. An interesting classification<sup>4</sup> of the level of autonomy is given in Table 1 from where it can be clearly noticed how the involvement of pilot in guidance and navigation is reduced as the level of autonomy increases.

It is possible to distinguish various levels of autonomy, starting from the commanded mode where the pilot has full authority on flight operations, going through several levels of semi-autonomous or assisted modes, where the pilot action is restricted to an advisory/support role, arriving to a completely autonomous mode, where the pilot is mainly a supervisor during UAV operations. This mode should also enable multi-UAV operations and lead to the scenario theorized by the Department of Defence for 2025, when the military aviation should be able to employ safely and synergically autonomous swarm of UAVs.

The challenge of enabling technologies is mainly is double: from one side, in fact, there is the big issue of acquiring the capabilities of ‘sense and avoid’. On the other side there is the urgency to provide the UAVs with capabilities of ‘decisions making’ and ‘problems solving’ to handle safely and effectively unforeseen changes in the operational scenario.

The decision making capability is for sure what is more strictly related to the level of system automation. In this context it is interesting to notice that there is a wide spectrum of variants and it is possible to distinguish at least two main categories: management-by-consent and management-by-exception. The difference lays in the way in which the operator is involved in the process. In the first case, the system proposes an action to take, but this is not confirmed until the operator do not give his/her consent. In the second case, the system proposes an action, which is taken without further confirmation, but the operator can have the authority of interrupting/modifying it with explicit instructions. In extreme situations the system could inform his supervisor of the action when it has already been taken and finished, or even not inform the pilot at all. Sometimes the two strategies are applied in parallel: the system could wait a few seconds to give the pilot the option to deny/permit and action and then take it if no definite answer has been given.

The sense and avoid capability is more related to flight control and is the challenge of today towards the line-off-sight automatic fly. Currently UAVs are operated mainly with two modes: manually or semi-autonomously. An example of manual control is the Predator, used by the U.S. Air Force. It is commanded by the ground station manually in all the flight phases, including takeoff and landing. The interface is very similar to the airplane’s. Every pilot has a joystick, a throttle and pedals. Opposite to this is the Global Hawk (also operated by USAF) which is highly automated. Both take-off and landing are automatic whereas mission is planned by the human operator, through the waypoints imposition. The control station looks very different from the Predator’s. The operators have monitors to supervise the flight plan and analyze data coming from the onboard sensors and payload. Mouse and keyboard are used to interact with the HMI for the parameter visualization, as well as for flight and mission planning.

## II. The Elettra Twin Flyer aerial segment

The low-cost multi-purpose multi-mission platform Elettra-Twin-Flyer (ETF) is being developed by the synergy of Nautilus S.p.A and the Politecnico di Torino<sup>5</sup>. It is a very innovative remotely-controlled airship equipped with high precision sensors and telecommunication devices. For its peculiar features, it is particularly suitable for inland, border and maritime surveillance missions and for telecommunication coverage extensions, especially in those areas which are either inaccessible or without conventional airport facilities and where the environmental impact is an essential concern.

ETF is characterized by great maneuverability as well as low wind sensitivity<sup>6</sup>. Flight conditions range from forward, backward and sideward flight to hovering, both in normal and severe wind conditions. To achieve these capabilities the ETF has been conceived with a highly non conventional architecture, where the aerodynamic surfaces have been substituted by thrust-vectoring propellers driven by electrical motors.

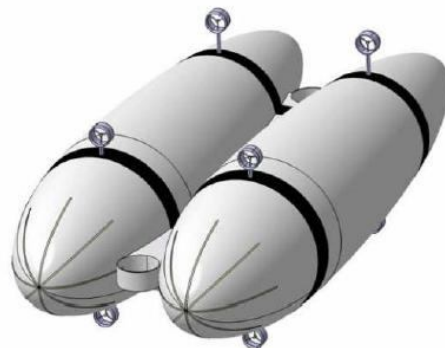

Figure 1 – Non-rigid double-hull configuration

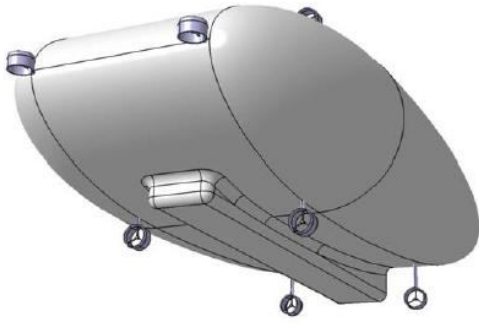

Figure 2 – Rigid soap-shape configuration

Flight tests are in progress on a Flight Demonstrator<sup>7</sup>, which is a reduced-scale reduced-complexity platform, purposely assembled to test the most critical subsystems, such as the command system and the architectural solution. Ground and flight tests are revealing that the architecture can be further optimized. For this reason the whole configuration is being reconsidered and different architectures are now being analysed under manifold points of view. Two examples are shown in Figures 1 and 2, from which it is evident that the command system is one of the main constraints of the project, meaning that whatever the platform shape, control is always guaranteed by trust-vectoring propellers purposely located to generate effective command moments.

Due to the high innovative platform features, Nautilus invested the early stage of the project in the development of a complete and refined Flight Simulator<sup>8-9</sup>, which proved to be essential for supporting the whole design process. In particular, as far as the human-machine interface is concerned, the flight simulator has provided in these years an effective tool for designing and testing hardware and software. From the pilot point of view, in fact, there are a very few differences in flying an unmanned vehicle or a simulator, unless psychological implications are considered, of course. In this context, the extensive activity conducted on the ETF Flight Simulator in the last years has revealed that the piloting strategy can be one of the weakest rings of the control chain. For practical reasons, in fact, piloting has been conceived as a simple imitation of the one implemented for the conventional manned aircraft. For this reason the pilot station has been equipped with a cockpit consisting of a double-throttle device and a three-DOF joystick. As for all the other UAV systems, the pilot inputs are sent to the aircraft, processed and re-allocated by the Control Allocation System<sup>10</sup>, which is embedded in the onboard computer. The control system has then the task of generating the desired commands in terms of propeller rotational speeds and orientations. The resulting piloting strategy is a hybrid between a helicopter and a conventional fixed-wing aircraft, which, at the end, does not please pilots in either category.

### III. The Elettra Twin Flyer Piloting Modes

Currently almost all the manned and unnamed aircraft are flown by mean of a throttle, combined with a stick and pedals. This configuration has always been considered the best compromise between two counteracting requirements:

- simplify the mechanical connections between commands and actuators
- reduce the pilot workload pursuing ergonomics and piloting intuitiveness.

It is becoming quite evident, however, that throttles and stick are restrictive for the EFT airship and the effort of adapting a conventional cockpit to the ETF airship could reveal useless or even counterproductive.

For this reason, a new user interface is being developed to minimize the pilot workload and enhance the ETF airship peculiarities, especially in hovering and near-hovering conditions. A drastic reduction of the pilot workload is also beneficial to increase the global situation awareness and safety, as a consequence. The ETF is also capable of semi-autonomous operations and the new interface must be able to handle high level commands, such as cursor-on-target path following on a GPS-referenced map.

The main component of the new interface is a commercial device, commonly named spacemouse, which is usually employed in the 3D CAD and CAE design and has proven to be particularly effective in reducing the discomforts associated to the handling of three-dimensional objects through a two-dimensional device, such as the monitor.

A single mobile component provides the user with the 6 degrees of freedom: it is hold with one hand and can be moved and rotated along the three axes. Common mice or trackballs work with two degrees of freedom and require auxiliary function keys or buttons. The difference is particularly evident when the control action requires fast and frequent accommodations.

The implementation is quite intuitive: it takes advantage of the spacemouse degrees of freedom, which are conceptually associated with the airship movements and rotations. Moving the spacemouse in the horizontal plane will cause the airship to move in the same plane, vertical displacements implies altitude variations whereas the three rotations control the ETF attitude. The transition between position and speed control is straightforward.

This strategy is being very effective in enhancing the airship peculiarities, maximizing handling and piloting qualities. The intuitiveness of this piloting technique proven to be also very helpful in reducing much of the stress

associated with critical operations, such as takeoff and landing. The synchronized use of two hands to coordinate speed and attitude is no longer necessary. This innovative piloting technique, moreover, can be easily decontextualized and applied to other UAVs, which could be flown even by little specialized pilots.

Elatra-Twin-Flyer can be flown in three different modes. In the first mode the airship is guided manually and commands are sent continuously in form of percentage of the active effective. A Stability Augmentation System guarantees a fairly good maneuverability in the whole flight envelope. In the second mode a Control Augmentation System is coupled with the airship dynamics. Commands are still sent continuously from the ground station, but in form of desired linear and rotational speed values. In the third mode control is fully automated, such that an autopilot maintains flight control using preprogrammed fly-to coordinates. In the following subsections these three modes will be further discussed.

### A. Remotely piloting mode

In the remotely piloting mode, commands are generated by the pilot through an HOTAS system, consisting of two throttles and a three-DOF joystick. The pilot inputs are processed and re-allocated by the Control Allocation System implemented on the on-board Flight Control Computer (FCC), in order to generate the desired commands in terms of propeller rotational speeds and orientations of the four thrust-vectoring propellers. The control strategies within the FCC have been developed for the two possible flight conditions: forward flight and hovering with/without wind. In forward flight, the joystick commands the orientation  $\delta$  of the four thrust-vectoring propellers for the lateral and directional maneuvers, as well as the differential variation of the angular rate of all the six propellers, generating the differential thrusts  $\Delta T_{ax}$  and  $\Delta T_{axVT}$  for the longitudinal maneuvers. The allocation strategy of the longitudinal control, shared between the forward and vertical propellers, has been purposely designed and scheduled to improve both the efficiency and the potentiality of this command, optimizing the airship performance in the whole speed range<sup>2</sup>. The two throttles act on the collective rotational speed of the four thrust-vectoring propellers and the two vertical axis propellers. In particular, the variation  $\Delta n$  of the propeller rotational speed in rounds per minute (RPM) is proportional to the square root of the throttle input  $\delta_{th}$ . This relationship has been imposed to obtain a linear relation between the command action and the generated thrust as the propeller thrust is proportional to the square root of the angular rate, according to the first *Rénard* formula<sup>11</sup>. All the six propellers can work in reverse mode with reduced efficiency. Moreover, the maximum collective thrust commanded by the throttle input  $\delta_{th}$  is only a reduced percentage of the total available thrust, while the remaining available thrust is dedicated to the commanded maneuvers, which are thus always achievable even when the throttle command  $\delta_{th}$  is maximum. The general scheme of the control strategy in forward flight is illustrated in Figure , in which it is highlighted the position of each propeller with the corresponding control action generating positive pitching, rolling and yawing moments, respectively, for longitudinal, lateral and directional maneuvers. The control allocation strategy is implemented on the board computer and is referred to as Control Allocation System<sup>10</sup>

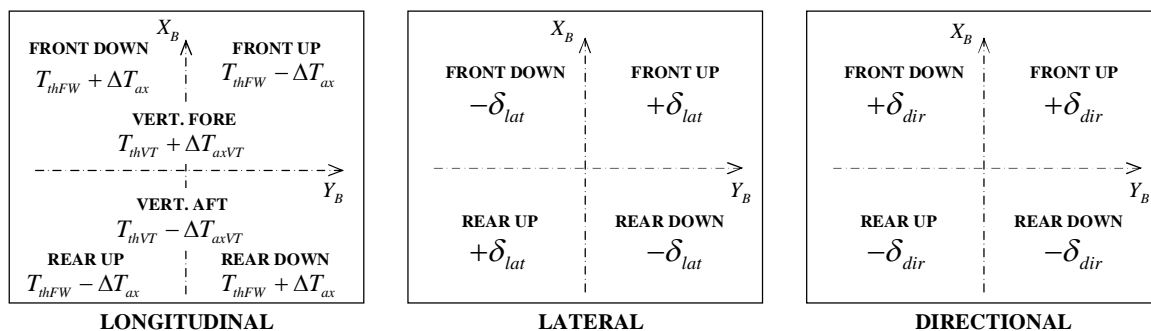

Figure 3 - Control strategy for longitudinal, lateral and directional maneuvers in forward flight

## B. Semi-autonomous mode

In the Semi-autonomous mode the airship is interfaced to a Stability and Control Augmentation system (SCAS) which enable the pilot to command in terms of desired linear and rotational speed values. This is the mode where the spacemouse is particularly effective as the degrees of freedom can be directly associated to the relative speed commands. The SCAS is based on a set of Linear Quadratic Tracker (LQT) controllers correlated with one another through a Gain-Scheduling Interpolation. Since the airship model is inherently non-linear, in fact, different LQTs gains have been selected to cover the flight envelope, with steps on the speed absolute value as low as 1 m/s. The interpolation is then linear in the operational range:

$$V_i < V < V_{i+1}, \quad K(V) = (1 - \lambda)K(V_i) + \lambda K(V_{i+1}) \quad (1.1)$$

Where  $V$  is the speed absolute value,  $K$  is the LQT gain matrix and  $\lambda$  is the interpolation fraction defined by:

$$\lambda = \frac{V - V_i}{V_{i+1} - V_i} \quad (1.2)$$

As the airship is capable of flying in any of the spherical  $360^\circ$  direction, though, a simple gain scheduling on the speed absolute value is not enough as it doesn't contain all the information about the operational point. For this reason the SCAS makes use of a set of five 3-D matrices from which the input trim values can be retrieved as a function of  $V$  and of the slope angle  $\gamma$

$$u = u(V, \gamma) \quad (1.3)$$

where  $u$  can be any of the input vector parameters

$$u \in \mathfrak{R}^5, u = \{\delta_{LON}, \delta_{LAT}, \delta_{DIR}, \tau_{FW}, \tau_{VT}\}' \quad (1.4)$$

Semi-autonomous flight has been considered particularly interesting, for the ETF features, in those flight phases when the airship is hovering in the target proximity. Flight speeds are very low and displacements are reduced to small to medium adjustments.

## C. Autonomous mode

In the autonomous mode the airship is flown through a point-to-target procedure using preprogrammed fly-to coordinates. The pilot uses a very simple and intuitive Human Machine Interface (HMI) to impose a set of waypoints on a 3D map. The choice of these waypoints represent the first step of an iterative procedure which allows the system to select a path, which should be optimized, according to the airship dynamic features and the payload capabilities. It should also respect the constraints given by the ATM control while avoiding the threat areas.

Generally speaking, the path planning algorithms are becoming more and more strategic, as they are central in the development of autonomous platforms<sup>12</sup>. The strategies which can be implemented are manifolds, depending on the UAV features. They are usually based on various cinematic, dynamic and operative constraints, which can slightly change whether the UAV is a fixed-wing or a rotary-wing like aircraft. Typical constraints can be the minimum turning radius or the maximum climb ratio<sup>13-15</sup>. If the waypoints are also intermediate target, for example in a surveillance or monitoring mission, considerations on the payload performance and limitations might be included in the optimal trajectory generation<sup>16</sup>: depending on the payload mobility and inherent intelligence the aircraft might be forced to reduce the forward speed or to pass less or more closely to the given waypoint. Mathematically speaking, the majority of the trajectory generation methods consist of different ways of connecting together pre-determined potential flight segments into an optimal or near-optimal path. These include using a Hybrid A\* algorithm<sup>17</sup>, Voroni polygons<sup>18</sup>, probabilistic maps<sup>19</sup> and other graphical methods<sup>20</sup>. Some researchers are also experimenting with various analytical techniques to solve these path-planning problems, including singular perturbation<sup>21</sup>, genetic algorithms<sup>22</sup> and neighbouring optimal control<sup>23</sup> as well as other optimization techniques, such as the Sequential Quadratic Programming<sup>24</sup> method.

Without loss of generality, the optimal trajectory generation can be formulated as a minimization problem with three categories of constraints, related to the task, the environment and the platform itself. The last set of constraints traduces the fact that the UAV will move in a limited space, that aggressive manoeuvres should be avoided where possible, that the power request cannot exceed the expected performance and that actuators have physical limitations. Typical operative limitations are: an excessive turning radius, a too steep climbing or anomalous and sharp altitude changing. In this context it can be noticed that this kind of constraints are less stringent for the ETF platform, for its great manoeuvre capabilities, which include hovering and climbing angles up to  $90^\circ$ .

To couple the peculiar features of the ETF platform with the payload ones a dedicated HMI has been introduced: as explained in the next section, the pilot has the possibility of imposing different values to limit the airship manoeuvrability according to the payload limitations. If the pilot does not set different constraints the path planning algorithm generates autonomously the optimal solution, which must be ultimately accepted by the pilot according to a management-by-consent philosophy.

Path following is handled by a set of autopilots, based on LQT controllers coupled to the SCAS discussed in the previous session. Figure 4 shows an example for the longitudinal plane. The overall control system is modulated by a second order reference model defined by the transfer function:

$$ETF(s) = \frac{\omega_{n\_ETF}^2}{s^2 + 2 \cdot \xi_{n\_ETF} \cdot \omega_{n\_ETF} \cdot s + \omega_{n\_ETF}^2} \quad (1.5)$$

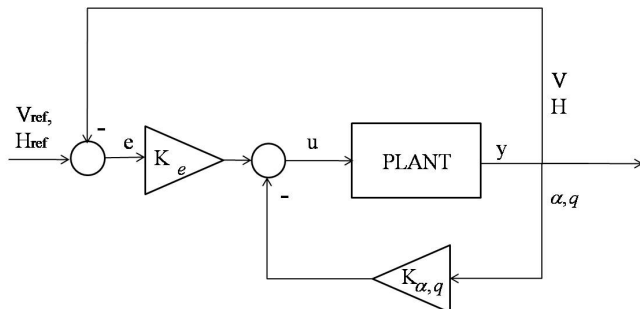

Figure 4 – Path planning control scheme (longitudinal degrees-of-freedom)

where  $\omega_{n\_ETF}$  and  $\xi_{n\_ETF}$  are representative of the ETF dynamic limitations. The time histories of Figure 5 show the performance obtained for longitudinal controller on the full non linear airship model implemented in the ETF Simulator. From the comparison between the desired and actual trajectory it can be evaluated that the tracking error is less than 0.3% on altitude. A bigger tracking error on speed can be justified by noticing that the test explicitly associates increasing request of speed to altitude gains, to stress the airship power capabilities.

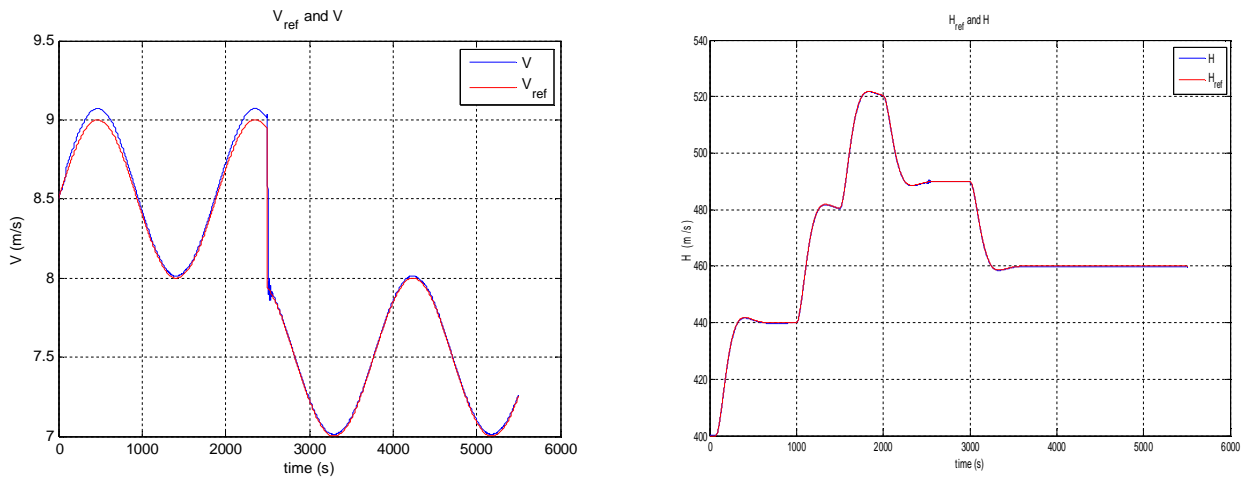

Figure 5 – Tracking errors on the speed and altitude loop

#### IV. The Elettra Twin Flyer HMI

HMI is one of the most critical element is UASs. To design an effective HMI, many aspects must be carefully evaluated. They are mainly related to the way information are displayed, gathered and positioned on the screens. One of the greatest limitations for the majority of the existing HMI, in fact, is that all the sensorial inputs, which are necessary to reach an adequate level of situation awareness, are usually conveyed in the visual channel. The eyes become the only receptors for stimuli which, on manned aircrafts, are usually perceived by the auditory or kinesthetic channel, as forces and accelerations experienced during flight. The vast literature on UAV issues clearly highlights how the sensory isolation is probably the most critical aspect in UAV piloting. Pilots do not have access to a wide range of multi-sensory information related to the environment in which they operate, which could be



otherwise very helpful to improve their situation awareness. It is common, hence, that often the HMI turns out to be inconvenient for the pilot, as it presents a large amount of visual information, among which it is hard to distinguish which data are actually necessary in the specific piloting phase (cognitive saturation). In some cases data, which are closely related to each other, are not gathered conveniently and the operator is forced to rapid eye or head movements, with a great physical and mental effort and a consequent rapid weariness.

Wickens and Holland<sup>25</sup> in 2000 proposed seven principles for the design of HMI in aviation, developed through an attentive study on the psychological process of information acquisition and processing. In 2001 the Global Hawk operators in Australia judged its interface unacceptable under several points of view<sup>26</sup>. Among the others, the major problems were related to the monitor disposition (too far away from each other), the process of target re-allocation (too complicated), fonts and colors (too difficult to read). These features are clearly symptoms of the violation of some of the principles of Wickens and Holland.

It must be considered, moreover, that the HMI is not the only filter between the data and the pilot: the data collected from the onboard sensors, in fact, pass through the data-link before being displayed. Quality and accuracy of the images received from the on board camera, for example, are limited not only by the sensor sensitivity but also, and more critically, by the link bandwidth and baud rate<sup>27</sup>. *Enhanced or synthetic vision systems (SVS)* are particularly useful to overcome these limitations. Studies conducted by Van Erp and Van Breda<sup>28</sup> in 1999 revealed that synthetic or enhanced vision systems (SVS) can increase accuracy and reduce the cognitive effort in performing manually the target-pointing task. Specifically, *enhanced vision* consists in merging (sensor fusion) images collected from multiple sensors, such as radars or infrared cameras, to provide the pilot with a more detailed and accurate scene. *Synthetic vision* is a 3D virtual representation of the environment, enriched with flight information arranged to mimic the head-up display (HUD).

These concepts have been incorporated in the ETF new HMI. The first user interface developed for the Flight Simulator<sup>9</sup> presented key information about flight and were gathered in the Flight Control Panel. It was specifically thought to provide the designers with a tool to design and test the Control Allocation System and perform ground test on the single control chains. For this reason it was specialized for the remotely-piloting mode and did not contain dedicated screens for mission planning. The new HMI has been completely revised in the respect of Wickens' e Hollands' principles and has been reorganized to include a *tactical display* and an *image management display*. They are arranged as to be contained in a single screen, together with a tool bar with button and sliding bars, which enable the pilot to optimize and personalize some of the window features, such as color contrast or sharpness, transparency, parameter ranges and so on. This screen has been positioned centrally and aligned with the pilot eyes. The Flight Control Panel is positioned on the left screen, whereas the right screen contains three virtual views of the airship. They have been arranged in order to have the pilot focused on the rear observer point of view, which has proved to be particularly useful in remotely piloting.

### A. Tactical Display

The *tactical display* reproduces the UAV path, waypoints, targets, threat areas and informs of the presence of other aircrafts, featuring the ATR (Automatic Target Recognition) system. This display is split in two parts, featuring respectively a 3D and a 2D map. The pilot interact with the tactical display during the mission planning phase, when the airship is set to fly autonomously. There are proper input/output fields, where the pilot can set critical parameter values he/she does not want to exceed, such as the minimum turning radius or the maximum climbing angle.

Within the ETF Simulator the maps are generated by integrating the display with the graphics engines of Google Earth and Google Map. The choice of such a versatile,

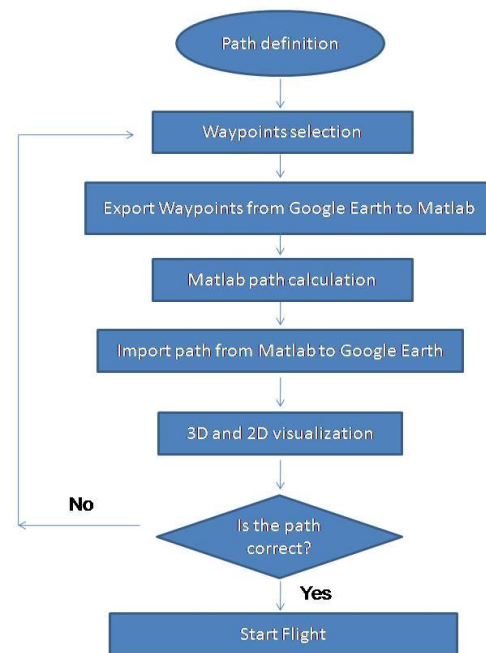

Figure 6 – Path definition procedure

widespread and inexpensive tool has proven to be very effective on the Simulator, as it has enabled cost cuts and a very quick and easy implementation. No advance programming skill, in fact, is necessary to integrate these features within html or applicative windows.

The 3D map features all the Google Earth functionalities, such as the possibility of selecting viewpoints. Data are exported from Google Earth in a format compatible with Matlab/Simulink, where they are processed through the path planning algorithms. Once the path has been calculated, it is displayed on the Google Earth 3D map, where the pilot can ultimately accept it, according to a management-by-consent philosophy. The path thus generated is displayed on both the 3D and the 2D maps together with the GPS positions of the airship and of the Ground Station. The sequence of the operations is sketched in Figure 6.

## B. Image Management Display

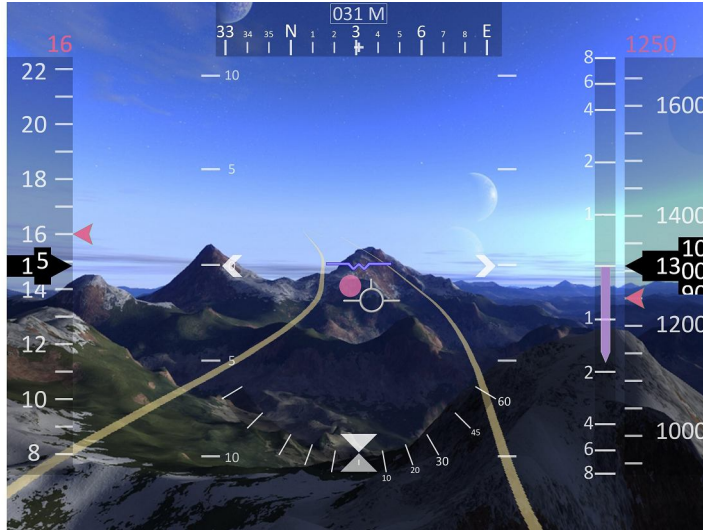

Figure 7 –HUD augmented with Synthetic Vision

The 3D *image management display* shows the images collected by the on-board video cameras and/or by other sensors, enriched with some of the information contained in the tactical display in a HUD augmented with SV (Figure 7). The display contains the classic indicators of altitude, speed, rate of climb, pitch, roll, heading and provide indication of the speed vector (direction of motion). The horizon has been eliminated for graphical reasons. Its function is now performed by the two V-shaped white arrows which points on the pitch scale and by the heading horizontal bar. The pathway has been added in forms of rails<sup>29</sup>. The use of rails (resulting in the absence of sidewalls) rather than a box or a tunnel is intended to indicate that no real hard lateral constraints exist. In case the situation requires the pilot to deviate from the planned path, a new path is calculated in real time (dynamic path). The pink circle in the middle of the path indicates the nominal position which is associated with the values of altitude and speed shown in pink on the sidebars. To minimize the tracking error the pilot has to maintain the white aircraft symbol on the pink circle.

To increase the level of realism and to comply with the regulations<sup>30</sup>, the pitch scale, which has a resolution of 5 *degrees*, has been designed so as to truly represent a width of 5 *degrees*, if observed on a 19 *inches* screen, with a 4:3 aspect ratio at a distance of 40 *cm* from the eyes.

## C. Flight Control Panel

The new features of the Flight Control Panel concern the way in which the speed information are displayed as a result of the commands given through the Spacemouse. An example is shown in Figure 8, where the blue bars show the command intensity, in terms of effectors percentage for the remotely-piloting mode and in terms of desired speeds for the semi-autonomous and autonomous modes. Bars represent translation, whereas the circles are for the rotational degrees-of-freedom.

The Flight Control Panel contains also a compass, which has both the representations *north-up* and *head-up*, in two concentric circles. The pilot can decide to maintain the double representation or can select one of the two, according to his/her own preference. The bottom part of the Flight Control Panel is dedicated to the diagnostics<sup>31</sup> and is thus highly specialized on the ETF on board components.

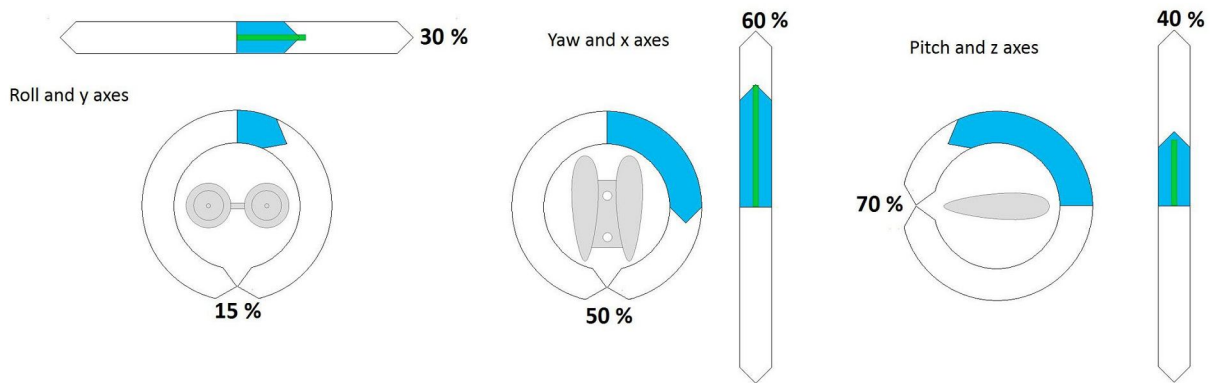

Figure 8 – Speed visualization on the Flight Control Panel

## References

- <sup>1</sup>Office of the Secretary of Defence, “Unmanned Aircraft Systems Roadmap 2005-2030”, Washington DC, August 2005
- <sup>2</sup>Clough, B.T., “Metrics, Schmetrics! How The Heck Do You Determine A UAV’s Autonomy Anyway?”, *Proceedings of the PerMis Workshop*, pp. 1-7, NIST, Gaithersburg, MD, 2002.
- <sup>3</sup>Breckon, T., Barnes, S., Eichner, M., Wahren, K., “Autonomous Real-time Vehicle Detection from a Medium-Level UAV”, *Proceedings of 25<sup>th</sup> UAV Bristol conference*, pp. 29.1-29.9, University of Bristol, Bristol, UK, 2009
- <sup>4</sup>Taylor, Robert M., Brown, Lex ; Dickson, Blair, “From Safety Net to Augmented Cognition: Using Flexible Autonomy Levels for On-Line Cognitive Assistance and Automation”, *Proceedings of RTO HFM Symposium on Spatial Disorientation in Military Vehicles: Causes, Consequences and Cures*, DTIC, Fort Belvoir, VA,
- <sup>5</sup>Inventors: Gili, P.A., Battipede, M., Icardi, U., Ruotolo, R., Vercesi, P., Owner: Nautilus S.p.A. and Politecnico di Torino, “Dual hull airship controlled by thrust vectoring,” N. PCT/EP03/08950, August 2003.
- <sup>6</sup>Battipede, M., Lando, M., Gili, P.A., Vercesi, P., “Peculiar Performance of a New Lighter-Than-Air Platform for Monitoring”, *Proceedings of the AIAA Aviation Technology, Integration and Operation Forum*, AIAA, Reston, VA, 2004.
- <sup>7</sup>Battipede, M., Gili, P.A., Lando, M., “Prototype Assembling of the Nautilus Remotely-Piloted Lighter-Than-Air Platform”, *Proceedings of the AIAA Aviation Technology, Integration and Operation Forum*, AIAA, Reston, VA, 2005.
- <sup>8</sup>Battipede, M., Gili, P.A., Lando, M., Massotti, L., “Flight Simulator for the Control Law Design of an Innovative Remotely-Piloted Airship”, *Proceedings of the AIAA Modeling Simulation and Technologies Conference*, AIAA, Reston, VA, 2004.
- <sup>9</sup>Battipede, M., Gili, P.A., Lando, M., “Ground Station and Flight Simulator for a Remotely-Piloted Non Conventional Airship”, *Proceedings of the AIAA Guidance, Navigation and Control Conference*, AIAA, Reston, VA, 2005.
- <sup>10</sup>Battipede, M., Gili, P.A., Lando, M., “Control Allocation System for an Innovative Remotely-Piloted Airship”, *Proceedings of the AIAA Atmospheric Flight Mechanics Conference*, AIAA, Reston, VA, 2004.
- <sup>11</sup>Lausetti, A., Filippi, F., *Elementi di Meccanica del Volo*, Vol. 1, ed. Levrotto & Bella, Turin, 1955, pp. 61-88.
- <sup>12</sup>Pachter, M., Chandler, P. R., ‘Challenges of Autonomous Control’, *IEEE Control Systems Magazine*, vol. 18, no. 4, pp. 92–97, IEEE press, New York, NY, 1998
- <sup>13</sup>Anderson, E., Beard, R., McLain, T., ‘Real-Time Dynamic Trajectory Smoothing for Unmanned Air Vehicles’, *Control Systems Technology*, pp. 471- 477, IEEE press, New York, NY, 2005
- <sup>14</sup>Yang, G., Kapila, V., ‘Optimal Path Planning for Unmanned Air Vehicles with Kinematic and Tactical Constraints’, *Proceedings of the 41st Decision and Control Conference*, pp. 1301- 1306, IEEE press, New York, NY, 2002
- <sup>15</sup>Ambrosino, G., Ariola, M., Ciniglio, U., Corrado, F., Pironti, A., Virgilio, M., ‘Algorithms for 3D UAV Path Generation and Tracking’, *Proceedings of 45th IEEE Conference in Decision and Control*, pp. 5275-5280, IEEE Press, New York, NY, 2006

- <sup>16</sup>Meirui Sun, Rongming Zhu, Xueguang Yang X., 'UAV Path Generation, Path Following and Gimbal Control' *Proceeding of the conference in Networking, Sensing and Control*, pp. 870-873 IEEE Press, New York, NY, 2008
- <sup>17</sup>Cowling, J, Whidborne, J, Cooke, A., 'Optimal Trajectory planning and LQR Control for a quadrotor UAV', *Proceedings of the international conference control*, IET Journal of Control Theory and Applications, Melville, NY, 2007
- <sup>18</sup>Coleman, D., Wunderlich, J., 'An Optimal and Opportunistic Path Planner (with Obstacle Avoidance) using Voronoi Polygons', *Proceedings of the Advanced Motion Control*, IEEE press, New York, NY, 2008
- <sup>19</sup>Dogan, A., 'Probabilistic Path Planning for UAVs', *Proceedings of Unmanned Unlimited Systems, Technologies and Operations*, IEEE Press, New York, NY, 2003
- <sup>20</sup>Fukuda, T., Hosokai, H., Otsuka, M., 'Path Planning and Control of Pipeline Inspection and Maintenance Robot', *Proceedings of the IECON*, IEEE press, New York, NY, 1988.
- <sup>21</sup>Zhang, D., Xi, H., Yin, N.B., 'Simulation-based optimization of singularly perturbed Markov reward processes with states aggregation', *Proceedings of the conference in Advances in intelligent computing*, Springer, Berlin, D, 2005
- <sup>22</sup>Elshamli, A., Abdullah, H., Areibi, S., 'Genetic Algorithm for Dynamic Path Planning', *Proceedings of the CCECE Conference*, IEEE press, New York, NY, 2004
- <sup>23</sup>Lepetic, M., Klan ar, G., Skrjanc, I., Matko, D. Potoc nik, B., 'Time optimal path planning considering acceleration limits', *Proceedings of the conference in Robotics and Autonomous Systems*, pp. 199-210, Elsevier, London, UK, 2003
- <sup>24</sup>Wei, S., Zefran, M., DeCarlo, R., 'Optimal Control of Robotic Systems with Logical constraints: Application to UAV Path Planning', *Proceedings of the International Conference on Robotics and Automation*, IEEE press, New York, NY, 2008
- <sup>25</sup>Wickens, C. D., Hollands, J., 'Engineering psychology and human performance' (3<sup>rd</sup>ed.). Upper Saddle River, NJ: Prentice Hall, 2000.
- <sup>26</sup>R. Hopcroft, E. Burchat, J. Vince; Australian Government Department of Defence – Defence Science and Technology Organisation; *Unmanned Aerial Vehicles for Maritime Patrol: Human Factors Issues*, DSTO, Melbourne, Australia, 2006
- <sup>27</sup>J. S. McCarley, C. D. Wickens, 'Human Factors concerns in UAV flight', Institute of Aviation, Aviation Human Factors Division, University of Illinois at Urbana-Champaign,
- <sup>28</sup>Van Erp, J.B.F., & Van Breda, L. (1999). 'Human factors issues and advanced interface design in maritime unmanned aerial vehicles: A project overview', *Report TNO TM-99-A004*, Soesterberg, The Netherlands: TNO Human Factors Research Institute.
- <sup>29</sup>Theunissen, E.; Koeners, G.J.M.; Rademaker, R.M.; Jinkins, R.D.; Etherington, T.J, 'Terrain following and terrain avoidance with synthetic vision', *24<sup>th</sup> Digital Avionics Systems Conference*, Oct.-3 Nov. 2005 Page(s): 4.D.2 - 41-11 Vol. 1
- <sup>30</sup>Instrument Flying Handbook: FAA-H-8083-15A (FAA Handbooks series), U.S. Department of Transportation, Federal Aviation Administration, Flight Standards Service, 2007
- <sup>31</sup>M. Battipede, P. Gili, P.Gunetti, 'Validation of the Fault Mitigation Procedures for the Unmanned Elettra-Twin-Flyer Airship', *Proceedings of the AIAA Modeling Simulation and Technologies Conference*, AIAA, Reston, VA, 2007.