



POLITECNICO DI TORINO
Repository ISTITUZIONALE

Big electric scooter: an experience from lab to the road

Original

Big electric scooter: an experience from lab to the road / ARMANDO E.G.; PASTORELLI M; GUGLIELMI P; MARTINO M. - STAMPA. - (2008), pp. 1680-1684. ((Intervento presentato al convegno Industrial Electronics and Applications, 2008. ICIEA 2008. 3rd IEEE Conference on tenutosi a Singapore nel 3-5 June 2008 [10.1109/ICIEA.2008.4582805].

Availability:

This version is available at: 11583/2365647 since:

Publisher:

IEEE

Published

DOI:10.1109/ICIEA.2008.4582805

Terms of use:

openAccess

This article is made available under terms and conditions as specified in the corresponding bibliographic description in the repository

Publisher copyright

IEEE postprint/Author's Accepted Manuscript

©2008 IEEE. Personal use of this material is permitted. Permission from IEEE must be obtained for all other uses, in any current or future media, including reprinting/republishing this material for advertising or promotional purposes, creating new collecting works, for resale or lists, or reuse of any copyrighted component of this work in other works.

(Article begins on next page)

Big Electric Scooter: an experience from Lab to the road

Eric Armando, Paolo Guglielmi, Mariapia Martino, Michele Pastorelli*

Electrical Engineering Department - Politecnico di Torino

Corso Duca degli Abruzzi, 24 - 10129 Torino (Italy)

*Corresponding author: michele.pastorelli@polito.it

Abstract - Electric scooters are suited to mobility in zones with environmental traffic limitations, and particularly for city centers with very poor room for parking.

Aim of this paper is the illustration of the relatively high performance which can be obtained from a purposely designed electric scooter.

The features of the main components of the scooter drive: battery package, supply converter, motor and control are described.

I. INTRODUCTION

Hybrid and Electrical vehicles (HEV and EV, respectively) have become more and more usual in everyday life, but still far, in terms of diffusion, from the forecasted values of the near future.

Hybrid Vehicles are the solution where a significant range is necessary, while EV are suited to urban range, with particular advantages if the daily run can be predicted or if it is periodical (public services, express couriers, limited traffic city centers, car and bike sharing, airport auxiliary services). A typical example of such a vehicle is the electric urban scooter.

A fundamental part of EVs and HEVs is the electrical drive for traction. Concerning the drive, a clear standard has not still been evidenced: in most of recent cases synchronous motor drives are adopted for their better efficiency. The asynchronous motor, often used for simplicity, has lower efficiency and less overload capability, due to rotor losses.

Where the mechanical gear is avoided, to reduce the size of the power converter, it is convenient to choose an electric motor capable to provide constant power over a wide speed range (1:3, 1:4). Among synchronous motors, those able to suit such requirements are Interior Permanent Magnets (IPM) motors. About the power converter, the DC/AC inverter is very often associated to a DC/DC stage for improving the electrical coupling with the battery and, more in general, with the on-board energy supply.

A DC/DC converters on the DC link de-couples the DC/AC inverter and the motor from the battery voltage variation (due to load and state of charge drops), thus reducing the size of the DC/AC stage, as well as the reactive filter towards the battery. The on-board accumulator (typically batteries) still represents the most delicate point in terms of influence on the overall vehicle performance, the progress in this field has been continuous and promising.

Of course, the commercial success of the HEV architecture has mainly pulled those technologies committed to high power-density (e.g. Ni-MH), rather than those for high energy-density (Li-based).

Nevertheless, the most recent Li-ion and Li-polymers cells have very good energy levels, still in progress, and satisfactory power-density.

There are many and stimulating opportunities of research and improvements in the field of electrical drives for traction.

Such opportunities involve several of the aspects of the drive: the motor as well as the power converters, the power interface towards the batteries and the optimal management of the accumulator's state. In particular:

1. the IPM motor must be specifically designed for the application: the overload ratio and the constant power speed range have to be considered. The motor design must also minimize the iron loss at high speed, in order not to compromise the system efficiency at full speed. Actually there is not a design standard widely recognized.
2. The DC/DC conversion stage should be able to interface all the accumulators on-board, to have an optimal exploitation of any single source. Many solutions have been already proposed but still no clear comparison has been given.
3. The battery pack management must fully exploit all the cells, in charging and regeneration modes. At the state of the art no clear solutions exist.

To answer to the above mentioned marks is the key-point to give a standard to the electrical drives for traction.

II. THE BIG ELECTRIC SCOOTER (BES) PROJECT

The optimal range of an urban electric scooter must not be as big as for gasoline scooters: few kWh storage are widely enough, if high capacity battery modules are adopted, this result in a rather light battery pack.

On the opposite, to fulfill the customer expectations in terms of performance and give a quick response over the traffic in town, the installed traction power must be comparable to that of an analogous gasoline scooter. In order to face steep hill climbs, a good stall and low speed torque is necessary.

The project Big Electric Scooter (BES) has been developed in order to design and built an electric scooter to be used in urban environment.

This prototype have been built and tested and it is actually running: the BES is well appreciated and received some rewards in dedicated competitions [9]. BES has being for long time a test bench for students: more than 20 students dedicated their final thesis period on the different parts of this large project. Every part of the driveline has been designed, mounted and tested in the University Labs.

III. SPECIFICATIONS AND REQUIRED PERFORMANCES

The basic idea in BES is the high performances. The scooter has been designed to be competitive with the actual ICE (Internal Combustion Engine) scooter for a City (and not only) driving. Big size with two people on board, maximum speed comparable to ICE scooters, reliable autonomy for city driving and capability to cope with high gradability (to allow parking).

The chosen specifications are reported in Table 1 and the various subsystems (motor, power electronics, battery pack) were designed accordingly.

Concerning autonomy the values reported in Table 1 refer to a continuous run.

TABLE I
CHOSEN SPECIFICATIONS

Total weight (2 people)	~320 kg
Max Speed	90÷100 km/h
Gradability (low speed)	25%
Power	~ 7 kW
Constant-power speed range	3.5
Autonomy @ 50 km/h continuous	>130 km
Autonomy @ 90 km/h continuous	~ 60 km



Fig.1 – Photo of the Big Electric Scooter (BES).

In the urban context, frequent “stop and go” will lead to a different performance, which is affected by the regenerative braking system, too.

The chosen reference autonomy is largely sufficient for an urban and even suburban use, of course, such a performance implies the choice of suitable batteries.

IV. MECHANICAL TRANSMISSION AND CONSTANT-POWER SPEED RANGE

In order to simplify and to improve the efficiency of the mechanical transmission between the motor and the back wheel, a fixed gear ratio is chosen. This choice implies the need of a constant-power speed range for the motor drive, the value of the constant-power speed range depends on the required vehicle performance [2]. This is shown qualitatively in the force vs. vehicle speed plane (Fig. 2).

The maximum required force F_0 depends on the wanted low-speed gradability and acceleration; the force F_m at maximum speed is normally lower than F_0 .

Once the load vs. speed characteristic is given (Fig.2), F_m is directly related to the expected maximum speed. The constant-power speed range r is given by (1), where m is the total mass, g is gravity acceleration and ϵ is the slope angle.

$$r = \frac{v_m}{v_0} = \frac{F_0}{F_m} = \frac{mg \sin \epsilon}{F_m(v_m)} \quad (1)$$

If performances consistent with customer demand for urban use are assumed, i.e. 25% low-speed gradability ($\epsilon=14^\circ$), two-people vehicle ($m=320$ kg), maximum speed up to 90÷100 km/h with an average value for C_x coefficient the power required by the scooter is nearly 7 kW.

The resulting constant-power speed range is near to 1:3.5.

V. MOTOR DESIGN AND CONTROL

The electric motors to be taken into account for the project were restricted to a.c. motors, since the d.c. motor is penalized by many factors, such as reliability, maintenance, low speed and low torque density.

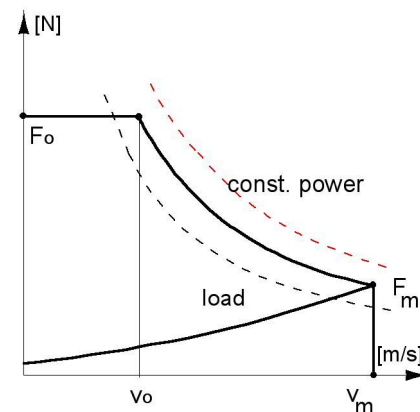

Fig. 2 – Required constant-power speed range.

In [1] a detailed comparison among induction, brushless (surface mounted permanent magnet), synchronous reluctance and PMASR (Permanent Magnet Assisted Synchronous Reluctance) motors is carried out and some a.c. motors performance indexes as torque density (Nm/m^3), required inverter size (kVA_{ref}) and total efficiency (motor and converter) are deeply analyzed.

As final results it is sufficient to say that the induction motor is penalized by the low motor efficiency, while brushless and synchronous reluctance motors require a larger inverter size due to the large constant-power speed range (around 1:3.5).

The best a.c. solution is represented by a Permanent-Magnet Assisted Synchronous Reluctance motor, which is an interior permanent-magnet (IPM) motor that shows a high anisotropy of the magnetic core (Fig. 3).

In this way the required constant power range can be obtained by the reluctance characteristic, while the amount of permanent magnet material is sufficiently low to guarantee the desired flux-weakening range, without an excessive increase of the inverter's size (kVA_{ref}).

Due to the low quantity of magnetic material employed in the motor, the overvoltage related to converter fault and consequent Uncontrolled Generator Operation (UGO) are reduced [6].

In Fig. 3 a cross-section of the motor is shown, where the four-pole, four-flux-barrier-per-pole rotor structure is pointed out. The outer stator diameter is 150 mm, while the core length is 142 mm.

Fig. 4 shows the PMASR motor during assembling, the total motor weight is about 20 kg. The cooling action is left to the incoming air flow, since a steady-state loading at standstill is not expected.

The motor base speed is 3000 rpm while the maximum speed is 10500 rpm. The fixed reduction ratio of the mechanical transmission is 1:10, this is a trade off between the motor size and the maximum motor speed.

The motor is equipped with an incremental encoder as shaft transducer.

The control is a vector control based on a flux observer, at low speed a magnetic model, measured by purposely developed tests is employed, while, at high speed, the voltage integration is adopted, as usual.

The reference values for the motor control are the d-axis flux (magnetic flux in the direction of lower magnet reluctance) and the q-axis current (90° apart from the d-axis, in the direction opposite to the permanent magnet flux).

This choice of reference quantities allows the control of the largest component of the flux and current vectors. Corrected control of the reference vectors is particularly useful at high speed, when they approach to the q axis.

At low speed the motor is controlled with reference commands defined as trade off between the point on the optimal torque over current ratio (max Nm/A) and the maximum motor efficiency.

At high speed, when the motor supply voltage is limited to the bus value, the motor reference command are fixed in order to maximize the motor efficiency, due to the high value of iron losses [7].

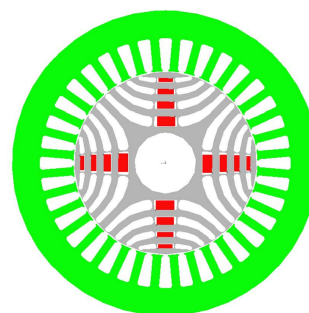

Fig. 3 – Cross section of the motor.



Fig. 4 – Permanent-Magnet Assisted Synchronous Reluctance (PMASR) rotor during motor assembling.

VI. BATTERY PACKAGE

The batteries to be adopted in the BES must show proper electrical and chemical characteristics to satisfy the required performance, moreover to increase the system reliability they must show long lifetime and high degree of safety.

The final choice was the employ of Li-ion batteries, which are gaining popularity over the traditional nickel based rechargeable batteries.

The greatest advantages of Li-ion batteries are the high cell voltage (3:1 compared with nickel technology) and superior energy density (roughly 2:1). Other attractive features are a very low self-discharge rate (about 1:4 compared with nickel technology) and no memory effect.

However Li-ion batteries are much less tolerant of abuse than nickel-based chemistries: overcharging and overdischarging greatly reduces cycle life.

The overcharge voltage is within a few percent of the desired full-charge voltage, requiring accurate voltage monitoring during charge to distinguish between full charge and overcharge [4] [8].

In order to avoid an incorrect use of the batteries, a properly designed battery protection circuit is employed, its main functions are:

- overload and short circuit protection by monitoring of the discharge current;
- monitoring of the battery voltage, in order to avoid overcharging and overdischarging.

According to manufacturer specifications the cell charge must be stopped if voltage exceeds 4.2 V and, additionally, cell discharge must be stopped if cell voltage falls below the 2.7 V limit.

The cell voltage monitoring circuit consists of a precision temperature compensated voltage reference and of a resistor voltage divider to sense cell voltage. The voltage of each cell is continuously compared with the voltage reference in order to measure the cell voltage value; a suitable hysteresis is implemented to prevent oscillations and the measurements are processed by a low pass filter to avoid unwanted voltage alarms during transients.

The output of the voltage monitoring circuit is send, by an array of optocouplers, to the DSP, thus the control can set the parameters according to the cell status. If a cell is detected in the undervoltage status the current from the batteries is reduced and a lower value of the maximum current is set. This procedure reduces the dynamic of the vehicle, but it can increase the autonomy.

The battery protection circuit is directly installed inside the case of the battery package and, even if it is powered continuously, it has a current consumption lower than the self-discharge rate of the battery.

In order to store the maximum amount of energy the cells must be individually equalized during charge operation, this is to reduce the intrinsic cell imbalance due to manufacturing differences.

The cell charge balance is performed by a protected FET (proFET) in parallel to each cell, this solution solves the problem of charge balance by a resistive switching, it has obviously the disadvantages related to the use of dissipative components, but shows the advantage to carry to a relevant simplification of the circuit topology.

The battery protection and charge balance circuit is mounted on a four layers printed circuit board and it is directly connected to the battery terminals by screwed bars, without any connection cable.

Each board controls ten cells and its size (210 * 54 mm) is adapted to the total outer dimensions of ten adjacent cells.

A temperature sensor ensures that the battery pack temperature is limited to 70 °C, in order to prevent damage to the cells.

The BES requirements have been satisfied with 140 cells Li-ion 3.7V 10 Ah and they have been divided into 14 packs, mainly for monitoring and handling.

The complete battery pack of the scooter (140 cells on board) is composed by two independent batteries units, parallel connected through two dc/dc converters to a common dc link. Each battery unit is constituted of 70 cells, series connected to get a nominal battery unit voltage of about 260 V.

In case of fault at one 70 cells battery unit, the vehicle is able to operate, at reduced performance, with one battery unit only.

TABLE II
SINGLE CELL VERSUS BATTERY PACK

Parameter	Cell	Battery Pack (2 units)
Chemistry	LiCoO ₂	LiCoO ₂
Typ. Voltage	3.7 V	260 V+260 V
Minimum Capacity	10 Ah	10 Ah + 10 Ah
Minimum Energy Density	105 Wh/kg	105 Wh/kg
Max Dis./Charge Current	30 A / 20 °C	30 A / 20 °C
Cycle Life (minimum)	500 cycles	500 cycles
Initial Internal Impedance	≤ 6 mΩ	≤ 350 mΩ
Cell Weight	≤ 350 g	≤ 49 kg
Discharge Temperature	-20 ... 60 °C	-20 ... 60 °C



Fig. 5 – Converter for Big Electric Scooter.

VII. CONVERTER STRUCTURE

The basic idea is to employ high voltages and consequently low currents.

The converter structure is included in an air cooled pack (300 * 200 * 20 mm) and composed by:

- power board: 2 H-bridge, 1 tree-phase inverter, 1.5 kW/220V recharging circuitry (PFC included);
- control board: FPGA-based control, DSP supervisory system;
- SMPS and 12V generation for on board services;
- 2 coupling inductors;
- pre-charging circuit and all sensing systems.

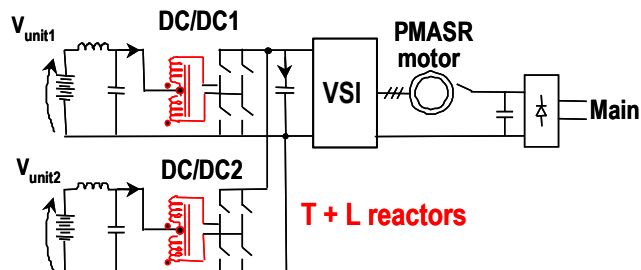

Fig. 6 – Double battery unit, cascaded DC/DC/AC complete conversion structure.

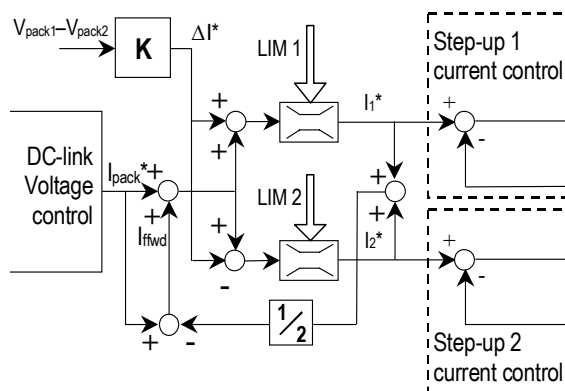

Fig. 7 – Control strategy for the DC-link voltage regulator.

The complete power conversion scheme is reported in Fig. 6, where the two battery units and the related H-Bridge DC/DC converters are shown. The reactive components (transformer and inductor) are integrated in one core [3].

The control of the two step-up converters, paralleled on a common dc-link, basically consist in the current sharing strategy.

The DC-link voltage regulator generates a battery pack reference current (I_{pack}^*), if the two battery units are in identical charging state the value I_{pack}^* is assumed as reference current for both the battery units. Whenever some differences in the battery units occur, different currents (for each battery unit) are set, in order to reduce the voltage mismatch between the two units (the unit with lower voltage needs lower discharge or higher charge current). The proportional compensation is shown in Fig. 7. A further current references conditioning comes from the saturation blocks (LIM 1 and LIM 2 in Fig. 7), given by the cell monitoring. If one of the two units is affected by the “LIM” current limitation, a feed-forward compensation attempts to keep the sum of the two pack current constant. This to limit the vehicle power derating if only one unit is affected by “LIM”.

Since the DC/DC converter has a multiphase structure, if locked timebases and proper PWM phase-shifting between the two H-Bridges are employed, a reduction of the ripple component and an increment of the ripple frequency can be easily achieved, allowing, as a consequence, a reduction of the RMS size of the DC link filter capacitor [5].

The charger is integrated inside the converter structure: during battery charging the rectifier stage is connected to the AC motor through the center-tap (Fig. 6).

The AC motor drive (motor + VSI) then works as a PFC step-up, consisting of three parallel branches (with the motor windings used as inductors), with individual current control, performing a Power Factor Compensated conversion towards the main. The DC-link voltage is set according to the maximum charge voltage of the two packs. Each pack is supplied by the corresponding DC/DC converter, according to the current limitation and the charge balancing concepts.

VIII. MISCELLANEOUS

The on board electric plant has not been modified at all as the braking system and on board instrumentation.

The scooter has been provided with a torque and power control: below 30km/h torque control is active, while beyond this limit power control is performed to give to the driver a good feeling in speed control capability and to copy, from the driver point of view, the behavior of an ICE scooter.

A reverse speed control has been integrated in order to move the scooter in short spaces or during parking.

IX. CONCLUSION

The main features of the Big Electric Scooter (BES) are illustrated and the peculiarities of the most important components are described. The prototype has been designed and built in the University Laboratories and presented at the “Formula TECH” competition sponsored by ATA (Italian Automotive Association). Researchers are still working on the project and improvements are expected in the cooling system and the battery monitoring where from the redesign of some components a better efficiency reduced dimensions are expected.

REFERENCES

- [1] Vagati A., Fratta A., Guglielmi P., Franchi G., Villata F.: “Comparison of AC motor based drives for electric vehicle application”, PCIM 1999, Intelligent Motion, Nurnberg, Germany, June 1999, pp. 173-182.
- [2] Casasso P., Fratta A., Girando G., Guglielmi P., M. Pastorelli M., Vagati A.: “High performance Electric Scooter”, PCIM 2003, Intelligent Motion, Nurnberg, Germany, May 2003, pp. 65-70.
- [3] Guglielmi P., Pellegrino G.M., Griffero G., Nieddu S., Girando G., Vagati A.: “Power conversion concepts for advanced autonomy and reliability electric scooter”, 29th IEEE IES Annual Conference IECON03, 2-6 Nov.2003, Roanoke (VA), USA, pp. 2883-2888.
- [4] Casasso P., Fratta A., Girando G., Guglielmi P., Villata F., Franceschini G., “Feasibility, Test and Novel Design of Battery Packs for EV Scooter”, 29th IEEE IES Annual Conference IECON03, 2-6 Nov. 2003, Roanoke (VA), USA, pp. 1649-1654.
- [5] Fratta A., Casasso P., Griffero G., Guglielmi P., Nieddu S., Pellegrino G.M., “New Design Concepts and Realisation of DC/DC Coupling Reactors for light EVs”, 29th IEEE IES Annual Conference IECON03, 2-6 Nov. 2003, Roanoke (VA), USA, pp. 2877-2882.
- [6] Vagati A., Guglielmi P.: “Design of PM assisted synchronous reluctance (PMASR) motors” in Design, analysis and control of Interior PM synchronous machines, edited by N. Bianchi & T.M. Jahns, CLEUP, (Italy) ISBN 88-7178-898-2, Oct. 2004, pp 6.1-6.35.
- [7] Guglielmi, P.; Pastorelli, M.; Pellegrino, G.; Vagati, A.; Position-sensorless control of permanent-magnet-assisted synchronous reluctance motor, IEEE Transactions on Industry Applications, Volume 40, Issue 2, March-April 2004 Page(s):615 – 622.
- [8] Affanni A., Bellini A., Franceschini G., Guglielmi P., Tassoni C., “Battery choice and management for New Generation Electric Vehicles”. IEEE Transactions on Industrial Electronics, Vol.52, no.5, October 2005, pp 1343 – 1349.
- [9] Armando E., Brusaglino G., Guglielmi P., Martellucci L., Vignetta D.: “Formula Electric and Hybrid Italy: a competitive demonstration on research products from Academic Institutions”, EET-2007 European Ele-Drive Conference, Brussel (Belgium), May 30 – June 1, 2007.

This paper is related to the application 2007L9PZBZ003 of the MUR program PRIN07.