



POLITECNICO DI TORINO
Repository ISTITUZIONALE

Measurement Procedures for the Electrical Characterization of Oxide Thin Films

Original

Measurement Procedures for the Electrical Characterization of Oxide Thin Films / CARULLO A.; GRASSINI S.; PARVIS M.. - In: IEEE TRANSACTIONS ON INSTRUMENTATION AND MEASUREMENT. - ISSN 0018-9456. - STAMPA. - 58:5(2009), pp. 1398-1404. [10.1109/TIM.2008.2009035]

Availability:

This version is available at: 11583/2263467 since:

Publisher:

IEEE / Institute of Electrical and Electronics Engineers Incorporated:445 Hoes Lane:Piscataway, NJ 08854:

Published

DOI:10.1109/TIM.2008.2009035

Terms of use:

openAccess

This article is made available under terms and conditions as specified in the corresponding bibliographic description in the repository

Publisher copyright

(Article begins on next page)

Measurement Procedures for the Electrical Characterization of Oxide Thin Films

Alessio Carullo, Sabrina Grassini, and Marco Parvis, *Fellow, IEEE*

Abstract—This paper describes a measurement system for the electrical characterization of oxide thin films. Such films can be produced using plasma-sputtering processes and permit the realization of a large set of high-performance components, such as capacitors, active devices, sensors, and protective coatings. The electrical properties of the oxide films, which have a thickness of less than 1 μm , are difficult to measure since very high resistances (on the order of gigaohms) and small capacitances (on the order of picofarads) are expected for contact areas smaller than 1 mm^2 . The measurement system and the procedures described in this paper represent an alternative solution to the commercial devices, which usually employ a mercury probe for performing the contact with the specimen under characterization. Furthermore, the proposed system can be used not only to estimate the electrical properties of a single point but to evaluate the uniformity of oxide films on large specimens as well. The experimental results reported refer to valve-metal-based oxide films deposited in a lab-scale capacitively coupled parallel-plate reactor and show the effectiveness of the proposed procedures.

Index Terms—Electric variable measurement, permittivity measurement, plasma applications, thickness measurement, thin films.

I. INTRODUCTION

THE USE of oxide thin films deposited on metallic objects to create either protective coatings or insulating layers to be employed in metal–oxide–metal (MOM) devices is continuously increasing in different industrial fields. Plasma-sprayed oxide coatings (generally, ceramics such as TiO_2 , Al_2O_3 , ZrO_2 , and Cr_2O_3) are mainly used as wear-resistant coatings [1]; oxide thin films deposited in plasma glow discharge, such as SiO_x coatings [2], can be employed to protect metallic substrates against corrosion; and examples of MOM devices that are extremely diffused are discrete capacitors and integrated capacitors for memory devices (dynamic random access memory) [3], [4].

The film-insulating properties mainly depend on the process employed for the deposition of the oxide film, which affects the oxide chemical composition and its morphology and nanostructure. Over the past few years, several techniques have been developed to induce the formation of stable oxide films

on metal substrates, such as electrochemical reactions [1], [5], thermal oxidation [6], plasma-assisted deposition processes, or a combination of these [2], [7]–[10]. In particular, plasma techniques permit good control of the deposition process, thus obtaining thinner and more uniform films, which yield better electric characteristics of the final devices.

During the optimization of the deposition process, the availability of reliable measuring systems would be of great help for easily estimating the oxide electrical properties, but the actual measuring procedures are rather complex, are often slow to perform, and employ toxic materials. In this paper, two new procedures that are safe and allow fast measurements to be obtained at low and medium frequencies are proposed. The experimental results presented refer to the electrical characterization of valve-metal-based oxide films (ZrO_2 , Nb_2O_5 , and Al_2O_3), which are deposited on metallic substrates using plasma-sputtering processes in a lab-scale capacitively coupled parallel-plate reactor [11].

II. MEASUREMENT SYSTEM

Even though several commercial systems designed to characterize the electrical properties of insulation layers at frequencies of up to 1 MHz are available, open problems still remain, requiring new approaches to be developed. In this frequency range, the characterization is typically based on a conventional impedance analysis performed by employing either an LCR meter or an impedance analyzer; the problems are in the fixture, which is required to create a nondestructive contact to the specimen under test. Some solutions employ parallel-plate techniques [12]: The test fixture allows the specimen to be sandwiched between two circular parallel electrodes with diameters in the range of 5–50 mm. In this case, the problems are the electrode parallelism and the air gap between the specimen and the electrode. Both problems can be tackled by using micrometer screws to perform contactless measurement procedures. Such a solution allows relative uncertainties of about 10% in the frequency range of 1 kHz–1 MHz for oxides with permittivities between 5 and 10 but requires large specimens and is declared to be effective only for film thicknesses of above 1 mm, thus preventing its use for thin films.

Other commercial solutions are based on a mercury probe (see an example in [13]), which consists of capillaries with diameters on the order of millimeters that allow the contact with the specimen to be made using mercury. Such a solution is quite flexible and allows different contact configurations to be performed (front–front, front–back, and front–back with guard). It also enables the measurement of the capacitance–voltage

Manuscript received June 25, 2008; revised September 16, 2008. First published December 16, 2008; current version published April 7, 2009. The Associate Editor coordinating the review process for this paper was Dr. Samir Trabelsi.

A. Carullo and M. Parvis are with the Dipartimento di Elettronica, Politecnico di Torino, 10129 Torino, Italy (e-mail: alessio.carullo@polito.it).

S. Grassini is with the Dipartimento di Scienza dei Materiali e Ingegneria Chimica, Politecnico di Torino, 10129 Torino, Italy.

Color versions of one or more of the figures in this paper are available online at <http://ieeexplore.ieee.org>.

Digital Object Identifier 10.1109/TIM.2008.2009035

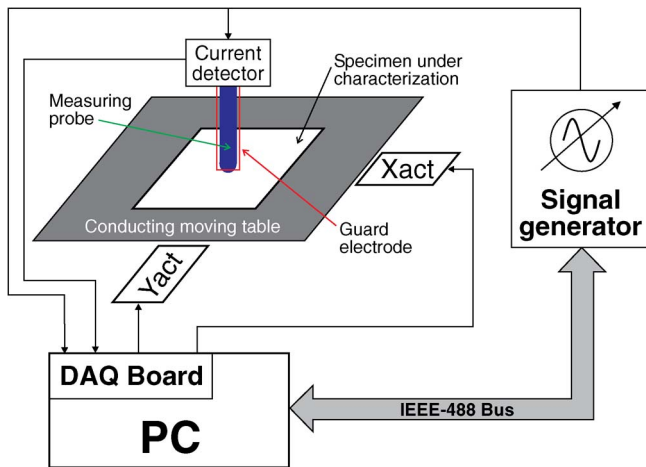

Fig. 1. Block scheme of the proposed measurement system.

or current–voltage parameters of the mercury–oxide–substrate structure and permits the estimation of parameters such as permittivity, resistivity, and dielectric strength; however, the necessity to perform in vacuum measurements and the toxic nature of the mercury make this technique not optimal. Furthermore, the mercury is difficult to manage and suffers from easy contamination: When such a contamination occurs, the mercury behavior dramatically changes, and the contact dimensions become difficult to be assessed.

With the aim to overcome the problems that are related to the commercial solutions, the authors have investigated two alternative approaches based on the following: 1) a metallic layer deposited on the specimen under investigation, which allows an average measurement on a large area to be obtained, and 2) a dry probe, which avoids the use of the mercury and allows easy measurement repetition and localization to be obtained. Both these approaches employ the same measurement system, which is based on a voltmeter device that allows the magnitude and phase of the specimen impedance to be estimated in the frequency range of 0.01 Hz–20 kHz. Fig. 1 shows a block scheme of the arranged measurement system: A programmable signal generator, which is controlled through an IEEE-488 interface, stimulates the specimen under investigation through a measuring probe, whereas a data acquisition (DAQ) board acquires the stimulus voltage signal and the voltage output of a current detector, which allows the current that flows into the specimen to be measured. The employed DAQ board is a 16-bit-resolution device with a maximum sampling frequency of 200 kSa/s. A circular guard electrode is mounted around the measuring probe to control the electric field shape.

A. Metallic-Layer-Based Solution

The first approach tested by the authors consists of depositing a metallic layer on the oxide film using a plasma-sputtering process. Such a metallic layer, which acts as an electrode of the specimen under investigation, allows a MOM structure to be realized. By using this solution, reliable measurements can be obtained since the contact area can be determined with high accuracy and it does not depend on external quantities, such

as contact pressure, and surface damages, such as scratches. In addition, since the electrode size can be changed as required, a large contact area can be realized, enabling medium impedance values to be measured and, thus, minimizing the effects of the parasitic parameters of the measurement system and the noise. As an example, by employing a circular electrode with a diameter on the order of 1 mm deposited onto an oxide film with a thickness on the order of hundreds of nanometers, the insulating resistance at low frequency is on the order of tens of megaohms, whereas the capacitance of the MOM structure is higher than hundreds of picofarads. On the other hand, this approach may take a long time to be implemented since a vacuum process is required and invasive: Apart from a few applications, it can be used only during the optimization phase of the deposition process.

B. Dry-Probe-Based Solution

This approach consists of using a thin moving probe placed in direct contact with the oxide film. The main advantage that such a solution offers is the possibility of carrying out localized measurements on the specimen, thus allowing the dispersion of its electrical properties to be estimated. With the aim to automatically perform such an estimation, the specimen is placed on a conducting table that is connected to two step motors, which allow an xy movement to be obtained. The motors are controlled through the same DAQ board employed for managing the acquisition process (see Fig. 1). Furthermore, this solution does not require any preparation of the specimen and is not invasive. Therefore, it is suitable for applications in the production phase, even though the oxide film can easily be damaged if a high contact pressure is employed or the probe is moved when in contact with the specimen. For this reason, hard materials should be avoided for the measuring probe, which has to be equipped with a force sensor to put it in contact with the specimen in a controlled way. In this paper, a solution based on a golden-plated brass probe has been investigated, which provided interesting results. One should note that the use of a soft material introduces a series of problems due to the probe deformation connected to the contact pressure, so that a careful probe modeling has to be employed, as will be explained later.

A preliminary problem that has been considered during the development of the thin-probe solution is probe dimensioning: Probe diameters of a few millimeters would lead to medium-value impedances, yielding more reliable measurements, but would not allow an accurate estimation of the contact area, due to both the irregularity of the probe surface and the oxide-film roughness. On the other hand, probe diameters of a few micrometers would allow better estimation of the contact area to be obtained but would lead to very high value impedances, whose measurements are significantly affected by noise and parasitic parameters (insulation resistance and stray capacitance) of the measurement system. An intermediate solution has therefore been adopted by employing a probe with a hemispheric tip with a diameter of about 100 μm , as shown on the right side of Fig. 2. An image of the tip obtained using a field emission scanning electron microscopy (FESEM) is shown on the left side of Fig. 2.

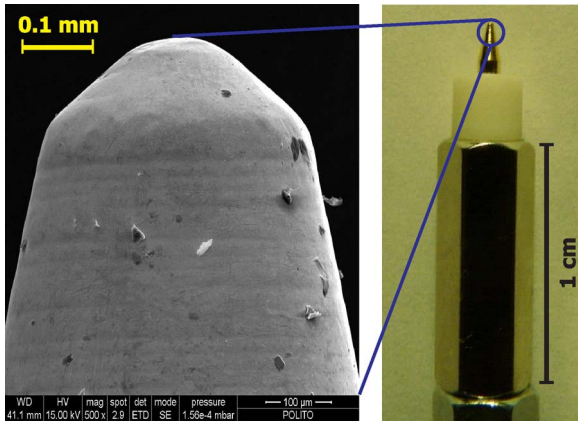

Fig. 2. Employed golden-plated brass probe. (Left) FESEM image of the probe tip.

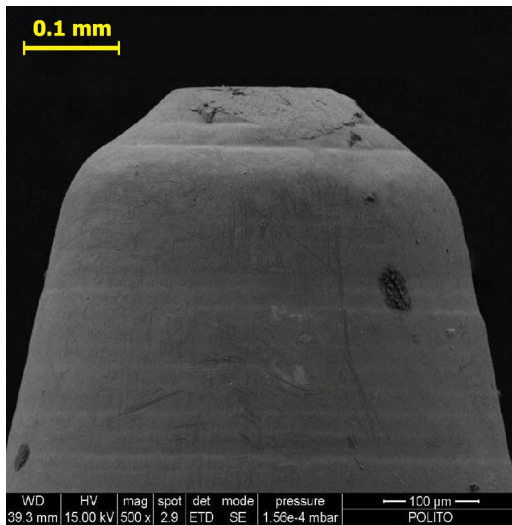

Fig. 3. FESEM image of the brass probe after it has been loaded with a force of 13 N.

With this low diameter, the contact force to which the probe is subjected can easily lead to stresses above the elastic limit and, thus, to permanent probe deformation. This effect can be employed to increase the probe contact area in a controlled way. The authors therefore decided to employ a force on the order of 10 N, whose expected effect is an increase in the diameter to about 150 μm . The use of a force of such a level is also important to ensure that the elastic probe deformation is enough to keep it in contact with the oxide film, regardless of its roughness.

Fig. 3 shows the same brass probe of Fig. 2 after a load of about 13 N has been applied and then removed. The probe is deformed, and the tip diameter is increased to 165 μm . Such a diameter increases to 175 μm when the probe is reloaded with the same force of 13 N due to the elastic deformation; therefore, this is the measuring probe diameter in use.

A further aspect that has to be taken into account to correctly characterize the specimen from a capacitive point of view is the shape of the measuring probe, which leads to a structure that is similar, although not equal, to a parallel-plate capacitor. A finite-element method (FEM) has therefore been implemented

to model the electric field around the probe by employing the MAXWELL software from ANSOFT Corporation [14]. The electric field configuration depends on the probe shape, oxide layer thickness, and, to a lesser extent, oxide permittivity. With the employed probe shape and a diameter of 175 μm , and a film with a thickness of 500 nm and a relative permittivity $\epsilon_r = 5$, the structure is equivalent to that of a parallel-plate capacitor with a capacity that is 3% greater than the estimated capacity. Such a difference would increase up to 40% if the diameter were on the order of 20 μm so that this analysis has to be carried out each time the diameter probe is changed.

III. EXPERIMENTAL PROCEDURE

The experimental procedure performed for estimating the electrical properties of oxide thin films consists of measuring the magnitude and phase of the specimen impedance in frequencies ranging from some hundredths of hertz to tens of kilohertz and then estimating the parameters of the equivalent electric circuit employed as a model of the oxide film, which, in this frequency range, can be assumed to comprise capacitor C_p shunted by resistance R_p . The resistance takes into account the insulation nature of the oxide film, and its estimation requires low-frequency measurements to be performed. The capacitance is related to the relative permittivity of the oxide film, whose estimation requires the contact area and the oxide thickness to be known.

The specimen under characterization is stimulated using a sinusoidal signal at different frequencies. The DAQ board acquires 100 000 samples of both the stimulus and output signals of the current detector. Then, the samples are processed using a modified three-parameter sine-fit algorithm, which estimates the magnitude and phase of the specimen impedance. Eventually, the measurement system systematic errors, mainly due to the transfer function of the shunt resistor and input amplifiers, are corrected.

The sine-fit algorithm on such a large number of samples is required since the specimen under characterization can exhibit a very high impedance, above all when the dry-probe solution is adopted; therefore, the current signal can have a very low amplitude that is similar to or lower than the noise. On the other hand, stimulus signals higher than a few volts cannot be employed due to the risk of breakdown on the oxide film (see the dielectric strength estimation for oxide films deposited using a sputtering process in [11]). Furthermore, with stimulus signals of a few volts, nonlinearity phenomena are expected, depending on the oxide nature.

The estimation of the relative permittivity ϵ_r of the oxide film is eventually performed from the measured capacity C_p , making reference to a parallel-plate capacitor model

$$\epsilon_r = \frac{C_p \cdot t_o}{\epsilon_0 \cdot A} \quad (1)$$

where A is the contact area estimated, as discussed in the previous section; ϵ_0 is the vacuum permittivity; and t_o is the thickness of the oxide film.

The film thickness depends on the deposition conditions and can be estimated by observing the FESEM image of the oxide

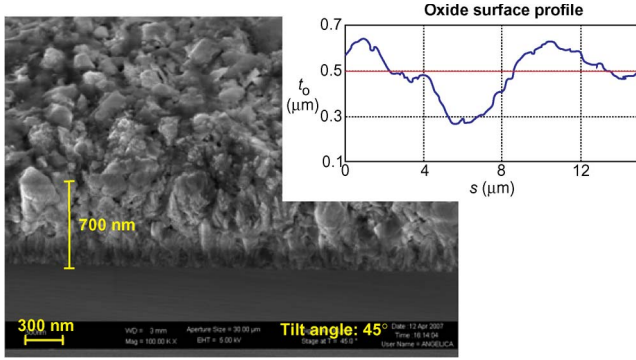

Fig. 4. FESEM image of the oxide cross section.

cross section. Fig. 4 shows an example of the FESEM image obtained with a tilt angle of 45° for a ZrO_2 oxide film. In this example, the average thickness value is about 500 nm, but the image highlights a remarkable roughness of the oxide surface, which makes it difficult to determine the correct value to be used for t_o in (1) in the case of the metallic-layer-based solution. In fact, the sputtering process produces an electrode that follows the oxide profile, making the parallel-plate model only a rough approximation. The problem can be solved by determining the actual roughness and using a FEM to solve the electric field and estimate the capacity. The roughness profile can be determined using an atomic force microscope, whose result for this specimen is shown in the top-right corner of Fig. 4. The trace shows that the thickness spans from about 280 to 650 nm around the average thickness of about 500 nm. With this profile, the FEM leads to a capacity whose value is equivalent to using a t_o value of 480 nm in (1), instead of the average 500-nm value. The FEM analysis needs to be repeated if either the thickness or the roughness properties change.

The correction for the roughness presence is much less important and can usually be neglected if the dry probe is used. In this case, a mechanical analysis shows that the soft nature of the probe allows it to be set to the average value but without entering the profile walls, so that the average thickness value can be used in the parallel-plate model without introducing significant errors.

The described experimental procedure has been employed to characterize different specimens, which have been prepared by plasma sputtering in a capacitively coupled parallel-plate reactor. Wide ranges of experimental process parameters have been tested, such as input power, Ar/O_2 flow ratio, and substrate temperature. Before the deposition, the substrates were submitted to surface pretreatments performed in oxygen-fed plasma to remove surface contamination layers. Then, depositions have been performed with radio frequency power (13.56 MHz) in the range of 150–750 W and substrate temperatures in the range of 25°C – 500°C . After the treatments, some of the specimens were subjected to annealing in air for 5 min at temperatures of 600°C and 900°C .

IV. EXPERIMENTAL RESULTS

The produced oxide films have been characterized from both an electrical and a chemical point of view. The film chemical

TABLE I
EXAMPLE OF THE RESULTS OBTAINED WITH SUBSEQUENT MEASUREMENTS ON THE SAME AREA OF THE SAME SPECIMEN

Test	R_p (G Ω)	C_p (pF)
1	0.95	3.07
2	0.96	3.10
3	0.94	3.09
4	0.95	3.08
5	0.95	3.06
..
Average	0.95	3.08
Standard deviation	0.74%	0.51%

composition and microstructure have been determined using X-ray diffraction (Philips X-Pert powder diffractometer) and FESEM (Supra 40 Zeiss Microscope) to evaluate the influence of the plasma process parameters on the microstructure and morphology of the deposited film. The main results of such a characterization, whose details can be found in [11], highlight that the input power is the parameter that mainly affects the morphology of deposited films. Furthermore, the films are characterized by a regular structure with crystals of less than 100 nm, with the exception of the annealed specimens that have crystals with dimensions of up to 300 nm.

The electrical properties of the oxide films have been obtained by employing the proposed measurement system: The investigated specimens are ZrO_2 , Nb_2O_5 , and Al_2O_3 nanostructured layers obtained under different conditions for the plasma process parameters.

Initially, the repeatability of the measuring system when the dry probe is used has experimentally been estimated, by performing subsequent measurements on the same area of the same specimen and under the same environmental conditions. An example of the results, which are expressed in terms of parameters R_p and C_p of the equivalent electric circuit employed as a model of the oxide film, is reported in Table I. The table also shows the average values of resistance and capacitance, and their relative experimental standard deviations, which are lower than 1%. Similar results have been obtained on other specimen types; thus, this deviation can be considered representative of the measuring system repeatability. The obtained repeatability can be considered satisfactory since it is better than the typical uniformity of the insulator layers deposited on metallic substrates, thus enabling the proposed system to be used for investigating the layer uniformity as well. As an example, tests performed on the different areas of the specimen whose results are shown in Table I led to a standard deviation of about 5% in the estimated parameters, whereas other specimens produced under more aggressive conditions easily lead to standard deviations of higher than 10%. Even though the lower impedances connected to the metallic electrode help in making the noise contributions less important, standard deviations that are only marginally lower have been obtained by repeating the measurements on the same metallic electrode of the same specimen. This behavior can be explained with the robustness of the data-fitting procedure, which also uses the measurements obtained at high frequencies, where the signal-to-noise ratio is high for both the dry probe and the metallic electrode.

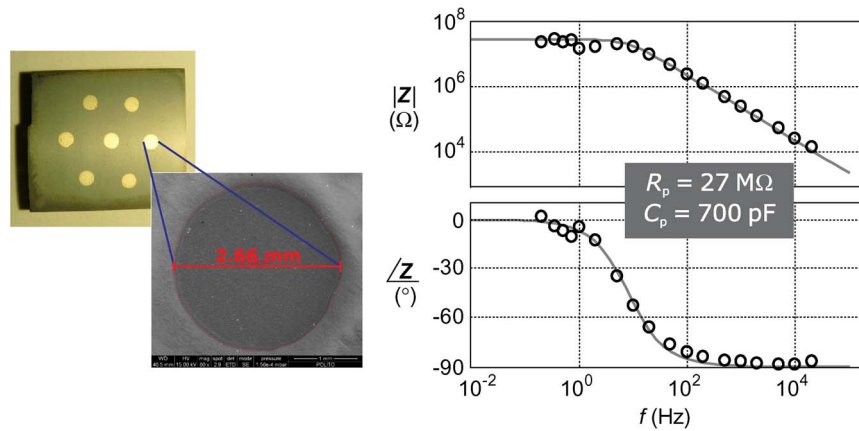

Fig. 5. Electrical characterization of a ZrO_2 oxide film using the metallic-layer solution.

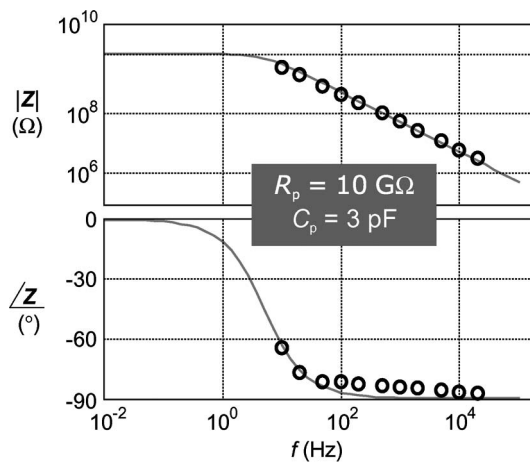

Fig. 6. Electrical properties of the ZrO_2 oxide film obtained by employing the dry-probe solution.

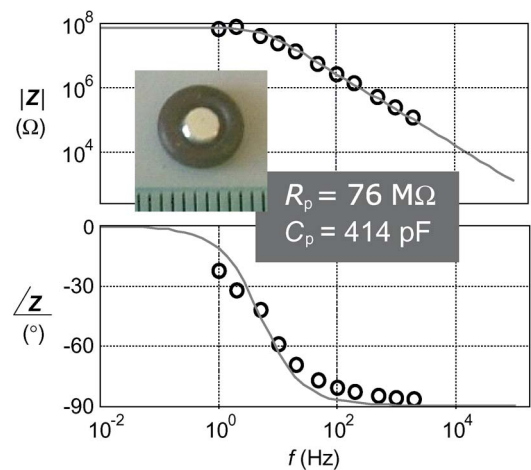

Fig. 7. Electrical properties of the ZrO_2 oxide film obtained by employing a mercury probe.

The measurement system has then been employed to estimate the properties of the ZrO_2 oxide film, whose structure is shown in Fig. 4. The specimen has been prepared with the metallic electrodes, so that both the proposed approaches (metallic layer and dry-probe solutions) have been tested on the same layer; in addition, comparison measurements have been performed by employing a mercury probe on the same specimen.

Fig. 5 shows the specimen under characterization, with seven silver electrodes deposited using a sputtering process. A FESEM image of an electrode is also shown, which allows a contact diameter of about 2.66 mm to be estimated. The uncertainty of such an estimation is mainly related to the measurement repeatability, whose relative value is on the order of a few percentages. The magnitude and phase of the specimen impedance obtained with the metallic electrode are also shown: The circles represent the measurements obtained at different frequencies, whereas the lines represent the plots of the magnitude and phase of the impedance of the identified oxide-film model. In this example, a resistance R_p of 27 $\text{M}\Omega$ and a capacity C_p of 700 pF have been obtained. The relative permittivity estimated using (1) is equal to 6.8.

Fig. 6 shows the results obtained by using the dry-probe solution: In this case, the parameters of the equivalent electrical circuit have been estimated in 10 $\text{G}\Omega$ for the resistance and 3.05 pF

for the capacity. The higher impedance values with respect to the metallic-layer solution leads to lower signal-to-noise ratios: For this reason, the results at frequencies lower than a few hertz have not been employed for the estimation of the specimen impedance since they are meaningless. The relative permittivity obtained using (1) with an oxide thickness of 500 nm and an equivalent contact diameter of 178 μm has been estimated to be equal to 6.9, which is in good agreement with that obtained with the metallic-layer solution. A preliminary uncertainty analysis that takes into account the main contributions, which are those of random nature, leads to a relative standard uncertainty for the estimated permittivity of about 3%. Such an uncertainty refers to measurements performed on a single specimen point; therefore, it comprises the measuring system repeatability but does not take the specimen uniformity into account.

A series of tests have also been performed for comparison by employing a mercury probe but without working in the vacuum. In this case (see results in Fig. 7), the estimated parameters are 76 $\text{M}\Omega$ for the resistance and 414 pF for the capacity, which, with an oxide thickness of 500 nm and a contact diameter of 2.4 mm, leads to a relative permittivity of 5.2. The disagreement with the previous results can easily be explained with the high surface tension of the mercury. The Hg drop is not able

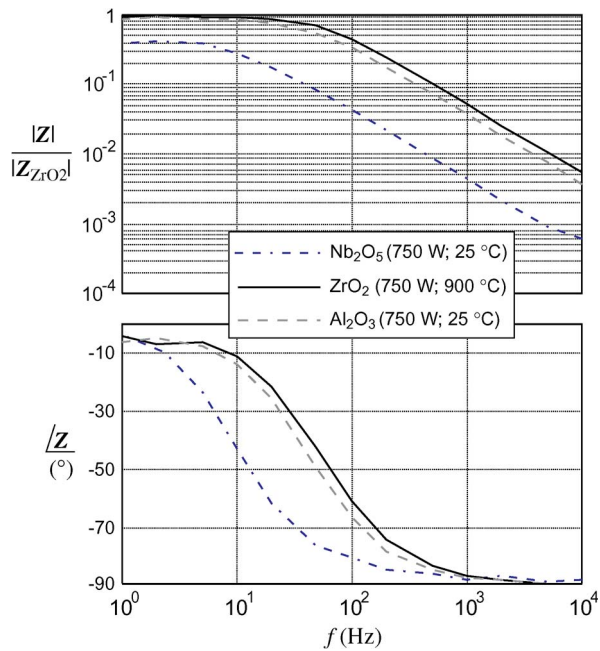

Fig. 8. Electrical impedance versus frequency measured with the dry-probe setup for three different types of specimens.

to follow the oxide profile; consequently, the presence of air between the drop and the oxide itself leads to an underestimated permittivity value.

Eventually, the proposed system has been used to compare the properties of three different types of specimens. The results, which are expressed in terms of electrical impedance, are summarized in Fig. 8. The best insulation properties are obtained with a ZrO_2 film deposited with a radio-frequency (RF) power of 750 W and subjected to an annealing process at 900 °C, whereas an Nb_2O_5 film deposited by employing the same RF power presents a lower insulation: Resistance R_p is about 40% of that obtained with the ZrO_2 film.

V. CONCLUSION

In this paper, two solutions have been described for the measurement of the electrical properties of oxide thin films that overcome the problems connected to the employment of commercial solutions, such as the electrode-parallel technique and the mercury probe. The obtained results have shown that the new techniques allow an easy characterization of the oxide properties to be obtained. However, the application of the dry-probe solution, which seems to be more suitable for the production phase, requires careful control of the contact pressure to reliably estimate the contact area and avoid damage to the oxide film.

Tests performed on specimens produced by the authors, with valve-metal oxide layers deposited using a plasma-sputtering process, have shown the capability of the proposed measurement system to characterize oxide films with very high insulation properties. The low-frequency resistance of the oxide film and its relative permittivity can be estimated with a relative standard uncertainty on the order of a few percentages. A further advantage that the dry-probe solution offers is the

possibility of not only estimating the electrical properties of a single point but also evaluating the uniformity and repeatability of the oxide layer on large specimens.

REFERENCES

- [1] E. P. Song *et al.*, "Correlation of microstructure with hardness and wear resistance of stainless steel blend coatings fabricated by atmospheric plasma spraying," *Mater. Sci. Eng. A*, vol. 429, no. 1/2, pp. 189–195, Aug. 15, 2006.
- [2] E. Angelini *et al.*, "PECVD organosilicon thin films for corrosion protection of metals," in *Trends in Electrochemistry and Corrosion at the Beginning of the 21st Century*, J. M. Costa, E. Brillas, and P.-L. Cabot, Eds. Madrid, Spain: Col-lecci3 Publicacions UB, 2004, pp. 979–999.
- [3] *Basic Tantalum Capacitor Technology—Technical Information*, AVX Ltd., Tantalum Div., Paignton, U.K., 1995. [Online]. Available: <http://www.avxcorp.com>
- [4] *Surface Mount Type Aluminum Electrolytic Capacitor—Technical Guide*, Matsushita, Kadoma, Japan, 2000.
- [5] K. Ohta *et al.*, "Quadruply self-aligned stacked high-capacitance RAM using Ta_2O_5 high-density VLSI dynamic memory," *IEEE Trans. Electron Devices*, vol. ED-29, no. 3, pp. 368–376, Mar. 1982.
- [6] G. S. Oehrlein, "Oxidation temperature dependence of the dc electrical conduction characteristics and dielectric strength of thin Ta_2O_5 films of silicon," *J. Appl. Phys.*, vol. 59, no. 5, pp. 1587–1595, Mar. 1986.
- [7] Y. Nishioka *et al.*, "Ultra-thin Ta_2O_5 dielectric film for high-speed bipolar memories," *IEEE Trans. Electron Devices*, vol. ED-34, no. 9, pp. 1957–1962, Sep. 1987.
- [8] M. E. Elta *et al.*, "Tantalum oxide capacitors for GaAs monolithic integrated circuits," *IEEE Electron Device Lett.*, vol. EDL-3, no. 5, pp. 127–129, May 1982.
- [9] S. G. Byeon and Y. Tzeng, "High-performance tantalum oxide capacitors fabricated by a novel reoxidation scheme," *IEEE Trans. Electron Devices*, vol. 37, no. 4, pp. 972–979, Apr. 1990.
- [10] L. Lowell, "Manufacturing and reliability improvements in metal-oxide-metal capacitors—MOMCAPs," in *Proc. IEEE/SEMI Advanced Semicond. Manuf. Conf.*, Apr. 1998, pp. 181–186.
- [11] A. Carullo, S. Corbellini, S. Grassini, and M. Parvis, "Development and analysis of procedures for the measurement of electrical properties of thin insulator layers," in *Proc. IEEE Int. Instrum. Meas. Technol. Conf.*, Vancouver, BC, Canada, May 12–15, 2008, pp. 557–562.
- [12] *Solutions for Measuring Permittivity and Permeability With LCR Meters and Impedance Analyzers*, Agilent Technol., Santa Clara, CA, 2001. Agilent Technol. Application Note 1369-1. [Online]. Available: <http://cp.literature.agilent.com/litweb/pdf/5980-2862EN.pdf>
- [13] *Mercury Probes*, Mater. Develop. Corp., Chatsworth, CA, 1999. [Online]. Available: <http://www.mdc4cv.com/mercuryprobe.htm>
- [14] *Simulation Software for High-Performance Electronic Design*, Ansoft Corp., Pittsburgh, PA, 2007. [Online]. Available: www.ansoft.com/products.cfm



Alessio Carullo was born in Italy in 1966. He received the M.S. degree in electronic engineering from Politecnico di Torino, Torino, Italy, in 1992 and the Ph.D. degree in electronic instrumentation from the Università di Brescia, Brescia, Italy, in 1997.

He is currently an Assistant Professor of electronic measurements with the Dipartimento di Elettronica, Politecnico di Torino, where he is responsible for SIT Calibration Center 139 and works on the development of intelligent instrumentation and the validation of automatic calibration systems.



Sabrina Grassini was born in Italy in 1972. She received the M.S. degree in chemistry from the Università di Torino, Torino, Italy, in 1999 and the Ph.D. degree in metallurgical engineering from Politecnico di Torino in 2004.

She is currently an Assistant Professor of chemistry with the Dipartimento di Scienza dei Materiali e Ingegneria Chimica, Politecnico di Torino. Her research interests include plasma chemistry and coating deposition, corrosion and protection of metallic materials, and the conservation of cultural heritage.



Marco Parvis (F'08) was born in Italy in 1958. He received the M.S. degree in electrical engineering from the Politecnico di Torino, Torino, Italy, in 1982 and the Ph.D. (Italian Doctorate) degree in metrology from the Politecnico di Torino in 1987.

He is currently with the Politecnico di Torino, where he is a Full Professor of electronic measurements with the Dipartimento di Elettronica and is also the Dean of the Second Faculty of Engineering for the term 2008–2011.

Prof. Parvis is a Fellow Member and the Chair of the TC 25 Medical Measurement of the IEEE Society on Instrumentation and Measurement.