

Large N.G. explosion and fire involving several buried utility networks

Original

Large N.G. explosion and fire involving several buried utility networks / Piccinini, N., Tommasini, R., Pons, E.. - In: PROCESS SAFETY AND ENVIRONMENTAL PROTECTION. - ISSN 0957-5820. - STAMPA. - 87:2(2009), pp. 73-80. [10.1016/j.psep.2008.02.007]

Availability:

This version is available at: 11583/2260555 since: 2024-08-21T10:30:52Z

Publisher:

Elsevier

Published

DOI:10.1016/j.psep.2008.02.007

Terms of use:

This article is made available under terms and conditions as specified in the corresponding bibliographic description in the repository

Publisher copyright

Elsevier postprint/Author's Accepted Manuscript

© 2009. This manuscript version is made available under the CC-BY-NC-ND 4.0 license
<http://creativecommons.org/licenses/by-nc-nd/4.0/>. The final authenticated version is available online at:
<http://dx.doi.org/10.1016/j.psep.2008.02.007>

(Article begins on next page)

Large N.G. explosion and fire involving several buried utility networks

N. Piccinini⁽¹⁾, R. Tommasini⁽²⁾, E. Pons⁽²⁾

⁽¹⁾ Dipartimento di Scienza dei materiali e Ingegneria Chimica

⁽²⁾ Dipartimento di Ingegneria Elettrica
Politecnico di Torino

Abstract

This paper describes an accident (explosion and natural gas fire) that occurred in Turin (Italy), in which power distribution cables, tramway network feeding cables and a gas pipe were involved.

The described accident is particularly interesting because it occurred in the town centre and lasted several hours, producing a very high risk for the population. Fortunately, nobody was injured, but 120 people were evacuated for 24 hours. The sequence of events is described, the involved facilities are examined and the physical processes which led to the different top events are discussed. Actually, starting from a modest event (600 V electric cable loss of insulation), which most likely lasted for months, the aforementioned accident was reached in a crescendo of domino effects. This sequence has been represented by an ISD in which the failure of the different protection systems is highlighted. These protection systems were mostly based upon the strict respect of procedures both in the installation and in the following maintenance of the different utilities. These aspects have been also briefly devised in the light of Italian and foreign regulations concerning the problem of the coexistence of buried utilities.

Keywords

Natural Gas; Explosion and Fire; buried utility networks; accident analysis.

Correspondence to:

Prof. N. Piccinini, SAfeR – Centro Studi su Sicurezza, Affidabilità e Rischi, Dipartimento di scienza dei Materiali e Ingegneria Chimica, Politecnico di Torino, C.so Duca degli Abruzzi, 24, 10129 Torino, Italy. E-mail: norberto.piccinini@polito.it.

Dr. R. Tommasini, Dipartimento di Ingegneria Elettrica, Politecnico di Torino, C.so Duca degli Abruzzi, 24, 10129 Torino, Italy. E-mail: riccardo.tommasini@polito.it

1. Introduction

In towns, where population densities are high, gas, water and electric power distribution utility networks coexist and are often buried close together. Moreover, most urban utility networks are quite old and breakdowns are not unusual. Maintenance operations, which require removing the paving and digging trenches, constitute extraordinary stresses on the networks that are not involved in the maintenance itself, but located nearby.

Because of the previously mentioned reasons, faults frequently occur and are likely to spread to the closest networks. Natural gas and electric power utilities are particularly critical for the safety of the population in the case of a fault. Two interesting cases are reported in the references (Casal *et al.*, 1995) and (National Transportation Safety Board, 2001a).

This paper describes an accident that occurred in Turin (Italy), in which power distribution cables, tramway network feeding cables and a gas pipe were involved.

The described accident is particularly interesting because it occurred in the town centre, at the crossroads between two crowded streets, lasted several hours (nearly 14 hours from when the first reports were made to the power distribution company until the fire was quenched) and produced a very high risk for the population. Fortunately no one was injured, but the effects could have been much worse.

The relevance of the age of the distribution networks and the consequence of maintenance operations on the development of faults emerges from an analysis of the accident here reported.

The domino effect, which from a small electric fault led to the natural gas explosion and fire, is also interesting.

2. The accident

On March 5, 2006 an explosion occurred and a natural gas fire started in a street in the center of Turin. Fortunately, no one was injured, however the damage to the installations was severe and 120 people living in the nearest buildings were evacuated for 24 hours.

At 13:48 of 5/3/06, a telephone call informed the fire brigade that a blackout had occurred and a small fire had begun in the basement of a building. The fire brigade arrived at the scene and found that there had been a short-circuit on a low voltage line. They also found a natural gas leak at the crossroads nearby.

More or less at the same time (13:58), the electrical company was informed of a blackout in the same building; the workers found that a circuit breaker had opened the low voltage line because of a fault.

Because of the persistent strong smell of gas, the electric company, following the directions of the fire brigade, switched off all the electric lines in the area. The buildings around the crossroads were evacuated (almost 120 people).

At 14:30, the gas company began working to find and stop the gas leak. At 19:00, the explosive atmosphere accumulated in the underground facilities ignited and exploded blowing out some manhole covers; a fire started.

Only at 3:30 the following day was the gas pipe interrupted and the fire put out.

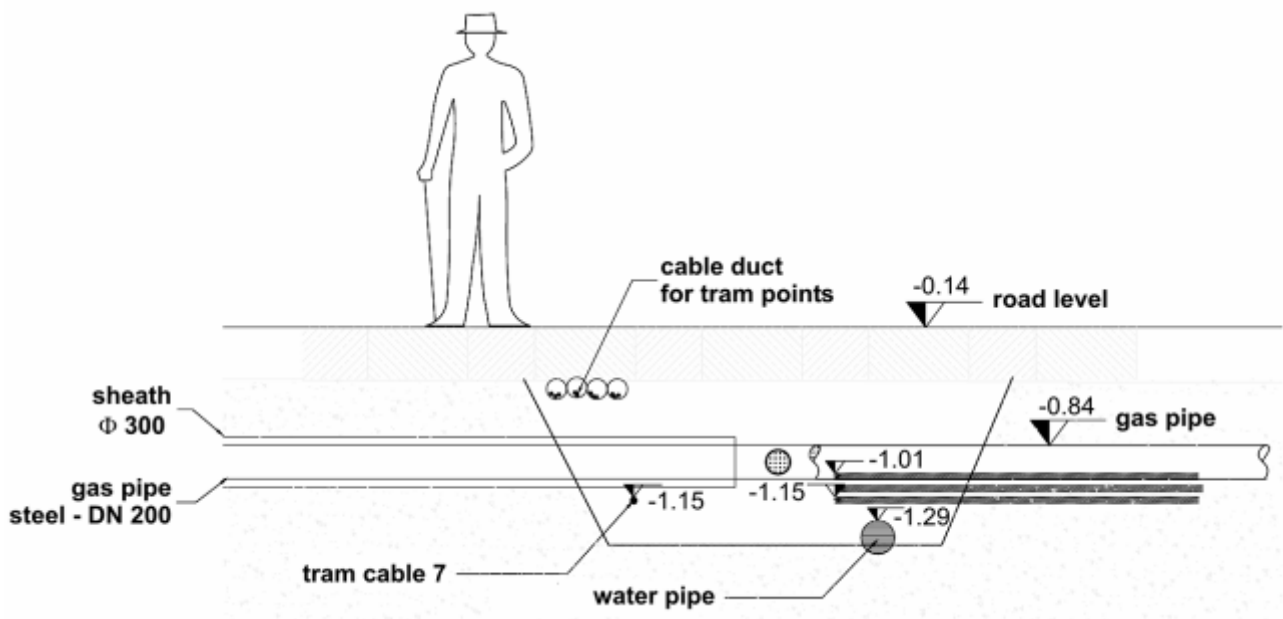

Fig. 1 – Depth survey

3. Description of the utilities

There were many buried utilities below the road where the accident took place; from the ground surface and going downwards (for a detailed depth survey see Fig. 1) there were: traffic lights, tram points, public lighting, power distribution and tram network power cables, gas pipes and water pipes. The layout of the lower installations is described in Fig. 3.

After the accident, the situation was left until the month of June, when a trench was opened to conduct the final repairs and, while working, it was possible to examine the utilities.

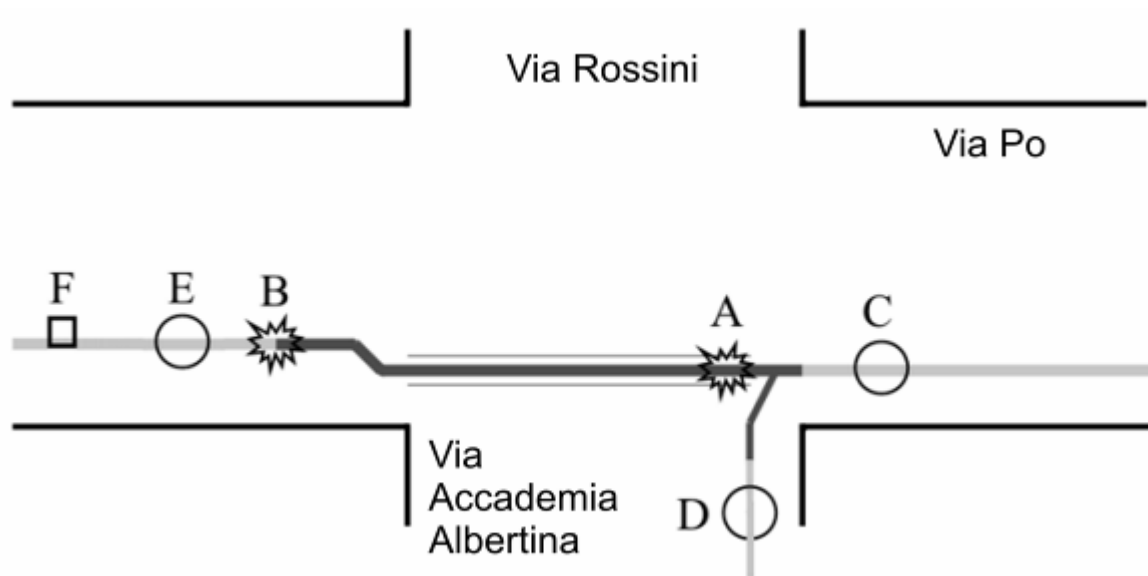

Fig. 2 – Gas pipe damage

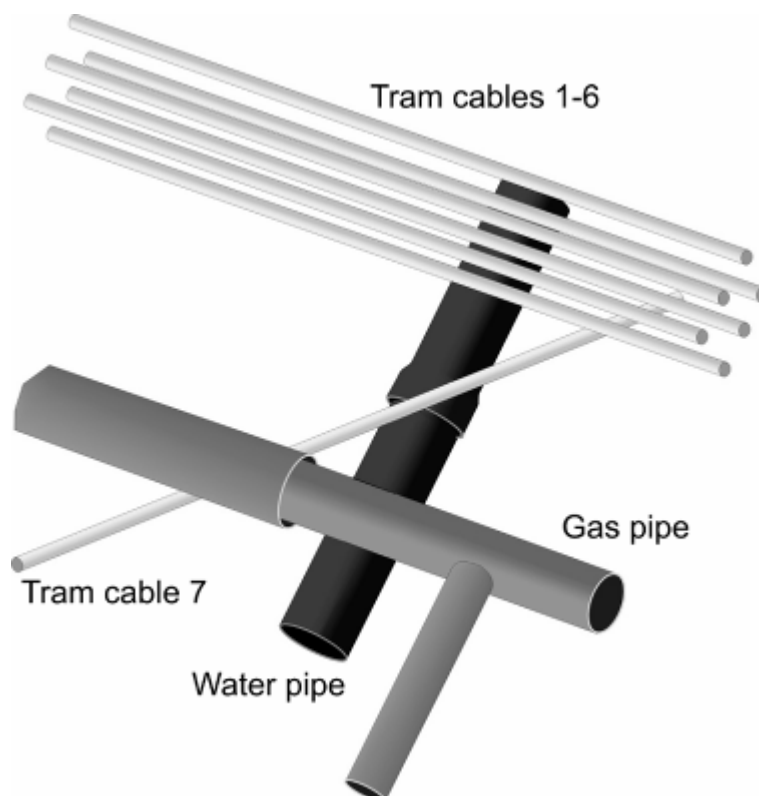

Fig. 3 – Lower buried facilities

Two damaged points, marked “A” and “B” in Fig. 2, were found along the gas pipe:

- damage point “B” was found at the junction between the steel pipe used to cross the road and the older cast iron pipe (see Fig. 4 and Fig. 5);
- damage point “A” was found where tram cable n.7 crossed the steel gas pipe (see Fig. 6).

While digging the trench where damage “A” occurred (see Fig. 8), it was found that tram cables 1-6 were fused together with the soil, and formed a vitrified mass (n. 6 in Fig. 8).

The fused cable ends were also visible (n. 3 in Fig. 8).

The following can be seen in the same picture:

- the gas pipe (n. 1, 2);
- the gas pipe sheath (n. 4);
- the damaged point “A” (n.5).

Gas pipe

The damaged gas pipe (a steel pipe, DN 200) is part of the low pressure distribution network, which is a close-mesh network, and it is therefore not possible to interrupt the gas flow to a damaged section by operating valves. In the case of gas leak, the gas company has to section the damaged pipe on both sides of the fault by boring the pipe itself and inserting rubber balloons, that are then inflated (these operations were carried out in the points marked with the letters “C”, “D” and “E” in Fig. 2). For these reasons, a great deal of time was required to stop the gas leak.



Fig. 4 – Gas pipe damage “B”



Fig. 5 – Gas pipe damage “B”



Fig. 6 – Gas pipe damage “A”



Fig. 7 – Water pipe damage

Tram cables

Electric cables 1-7 belong to the power distribution system of the tram network. They are fed at 600 V DC from a MV/LV substation through a double secondary transformer and an AC/DC converter and are connected to the overhead wiring to supply power to the vehicles. These cables are protected against overcurrents by extra-rapid circuit breakers that are set to trip for currents above 3000÷5000 A. Such high setting currents are required by modern tram vehicles but, unfortunately, in the case of a ground fault far from the substation, the fault current is often smaller than the setting of the circuit breaker and is

therefore interpreted as a normal operation current (Tommasini *et al.*, 2006). This certainly happened the day of the accident and the fault was then allowed to continue for a long time, producing a large amount of heat and extensive damage to the other facilities.

Cables 1-6 were made with EPR insulation and PVC sheath, with a cross-section of 1000 mm² and were protected by a PVC pipe. Cable 7 was an armoured cable, with a paper-oil insulation, a lead sheath, a PVC jacket, jute and bitumen and an outer mechanical shield of galvanized steel tape; its cross-section was 500 mm² and it was protected by a gres pipe.

The gres protection, however, was not found in the zone in which cable 7 crossed the gas and water pipes. It had probably been broken or removed during previous maintenance works.

The damaged terminals of the cables are shown in Fig. 9 and Fig. 10.



Fig. 8 - Trench

Power distribution system

The traffic lights and public lighting cables damaged at the site of the accident were fed by the power distribution network. The neutral conductors are never disconnected in this network and constitute a meshed grid. This explains how an overvoltage may have reached the electrical installations in the building near the crossroads. These installations were fed by a different line, which was not involved in the accident.

The short-circuit occurred in an old and probably already weakened line, at the same time as the main events. This was not coincidental, but due to an overvoltage transfer from the damaged tram cables to the weakened line by the neutral conductors.

Water pipe

The water pipe, which crossed the other facilities at a greater depth, was made of cast iron and was damaged by an electric arc on a joint, where cable 7 crossed it (see Fig. 7). This pipe was not totally perforated, probably thanks to the cooling effect provided by the water flowing inside.



Fig. 9 – Cable 7



Fig. 10 – Cable 1

4. Analysis of the accident

Main accident

No trace of the gres pipe which protected tram cable n. 7 was found near the gas pipe. This was probably damaged and removed during previous works (perhaps when the old cast iron gas pipe was substituted by the steel pipe in 1980). Moreover, the space between the gas pipe, the water pipe and the tram cables 1-6 was not sufficient to allow the gres pipe to cross (see Fig. 1 for details).

For the above mentioned reasons, tram cable n. 7 crossed the gas pipe and the water pipe without any protection and was almost in contact with them.

During the inspections after the accident, a water leak was found, at about 100 m from the crossroads where the accident happened; the water leak was caused by an old damaged lead pipe in the manhole marked with the letter "F" in Fig. 2. The street is slightly sloping, and the water therefore flowed through the PVC pipes of cables 1-6 and reached the accident area, where the terrain was flooded. This water flow accelerated the damage of cable 7, which started to leak current to the ground, through the gas and water pipes. In a vicious circle, the fault current produced heat, the heat accelerated the cable damage and the fault current increased.

The fault current was not detected by the circuit breakers and was allowed to last for a long time. The ground fault current is actually lower than the circuit breakers setting at the site of the fault.

The heat produced by the fault current and by the electric arcs damaged the gas and water pipes, fused the soil and also extended the fault damage to cables 1-6.

Moreover, the current flowing through the gas pipe also caused damage (due to corrosion and/or arcing) to the junction between the cast iron pipe and the steel pipe.

The damages to the gas and water pipes where GTT cable 7 was crossing are certainly not due to corrosion but to the high current flow because it was directed from the cable into the pipes. The path followed by the fault current is shown in Fig. 11, where:

A is the cast iron gas pipe;

B is the steel gas pipe;

C is GTT cable n. 7;

D is the gas pipe damage (letter A in Fig. 2);

E is the junction washer;

F is the gas pipe damage (letter B in Fig. 2);

G is the junction between the cast iron and the steel gas pipe;

H is the junction metal ring.

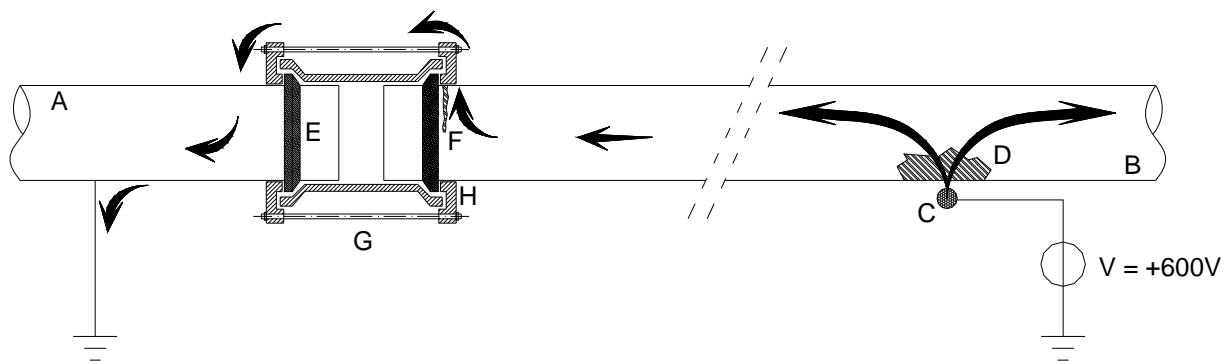

Fig. 11 – Path followed by the electric current

Underground temperature

An analysis of the cables, pipes and vitrified soil made it possible to determine the temperature reached below the road during the event. The melting point of copper is 1084°C, while the melting point of cast iron depends on its composition, but is around 1200°C; during the accident the electric cables melted but the pipes did not: the temperature reached in the natural crucible which formed under the road was therefore in the range of between 1100 and 1200 °C. At this temperature, the vitreous mass was

sufficiently fluid to be a good electric conductor (glass viscosity and resistivity in fact decrease with similar exponential laws with increasing temperature).

Short circuits in the building nearby

The short circuits were only a minor consequence of the previously described main events. The discharge between the electric line and its bearings was certainly due to an overvoltage; this discharge caused the circuit breaker to open the line and the small fire break out in the basement.

The line feeding the building, however, was not buried very close to the accident location. As previously mentioned, the neutral conductors in the power distribution system are never disconnected and the overvoltage was therefore transferred to the line by either the traffic lights or public lighting cables neutral conductors.

Nevertheless, a 600 V overvoltage is not sufficient to produce a discharge in a low voltage cable. The cable insulation was probably already weakened where the discharge occurred and this explains why the short circuits happened on one cable only (which also was quite old).

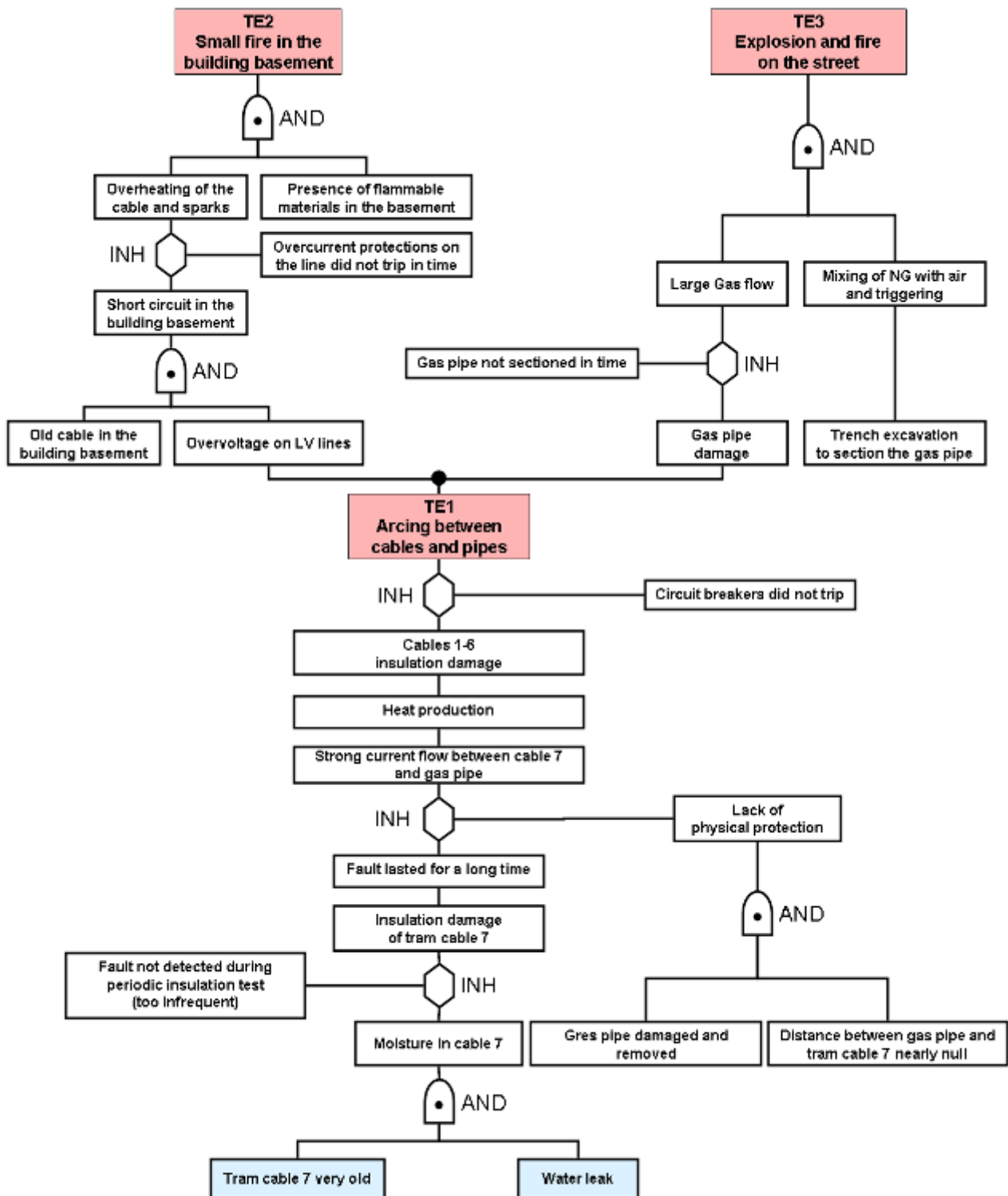

Fig. 12 – ISD presenting the domino effects and the failure of the protection systems

Domino effect

It is interesting to notice the domino effect which, from a small electric fault and despite the many protection levels, led to the natural gas explosion and fire. Actually, starting from a

modest event (600 V electric cable loss of insulation), which most likely lasted for months, the aforementioned accident was reached in a crescendo of domino effects. This sequence has been represented by an Incidental Sequences Diagram (ISD) (Fig. 12) in which the failure of the different protection systems is highlighted (Piccinini and Ciarambino, 1997). These protection systems were mostly based upon the strict respect of procedures both in the installation and in the following maintenance of the different utilities. In general the development of an accident or any undesired event (Top Event) can be ascribed to a process malfunction AND to the failure of both the automatic and manual protection systems; these may be due to different initiating events OR human errors of different kind. The representation of Fig. 12, which is called Incidental Sequences Diagram (ISD), is a causes/consequences logical graph similar to the better known Fault Tree representation. The construction of these graphs proceeds downwards with small logic steps from the Top Events to the Initiating Events, while their reading, or their numerical solution, proceeds in the opposite way: upward from the Primary Events towards the Top Event.

In the described approach, besides the AND logic gates, also the INH (Inhibit) gate has been used. This gate is specifically dedicated to draw attention to the protection systems: the input event of the inhibit gate becomes a more severe output if the protection system is already out of order when called to intervene and therefore does not block the phenomenon evolution (Demichela *et al.*, 2004).

5. Regulations regarding buried utilities clearance distances

The previously described accident was particularly severe because the fault that affected the electric cables also involved the gas pipe, and this happened because of the short distance and lack of protection between the two buried utilities.

A review of international and Italian regulations regarding spacing between buried electric cables and gas pipes is given in this section. This problem has recently been examined in other papers (Azcarraga and Garcia-Colon, 2004), (Parker and Ward, 2003).

In Italy, natural gas pipelines are subjected to the Ministerial Decree 24/11/84 (Ministry of Home Affairs, 1984). This law sets some general requirements about burial depths and distances from tram lines.

For pipelines with a pressure of up to 0,5 bar (the standard urban gas distribution networks are below this pressure value), this decree does not require minimum distances from other buried pipes or cables. The only requirement is that the distance should be sufficient to allow maintenance to both buried utilities.

Together with this decree, UNI-CIG¹ and CEI¹ standards are also applicable to this subject; they have legal bearing thanks to law 1083 of 1971 and law 186 of 1968.

CEI Standard 11-17 gives instructions on the protection of cables against stray currents and on the coexistence of power cables with other cables, buried metallic pipes or tanks, gas pipelines, railways, tram networks, etc. (CEI, 2006). This standard, however, does not apply to cables that are part of electric traction systems. The requirements of this standard are:

- for crossings between cables and pipes, the crossing itself should not be over or below unwelded pipe joints; power cables should not have splices closer than 1 m from the crossing point. The minimum distance should be 50 cm, but may be reduced to 30 cm if one of the facilities has a non metallic protection;
- parallel pipes and cables should be buried at the maximum possible horizontal distance, which should not be less than 30 cm. A smaller horizontal distance is

¹ See the Acronyms section

admitted only if the vertical distance is greater than 50 cm or non metallic protections are used;

- where cables cross railways, tramways, etc. they should be protected by robust pipes or tunnels, at a depth of no less than 1 m.

European Standard CEI EN 50122-2, which deals with protection against stray currents caused by DC traction systems, establishes that pipes and cables should be buried at a minimum distance of 1 m from traction systems (CEI, 1999).

A new set of Standards, CEI UNI 70029 and CEI UNI 70030 (according to the Italian Directive of 3 March 1999) , sets the basic requirements for the installation of buried facilities in new or completely renewed urban areas (CEI-UNI, 1998a), (CEI-UNI, 1998b), (Ministry of Public Works, 1999).

Italian Standard UNI 9165 does not specify a minimum distance for pipelines with a maximum operating pressure of up to 0,5 bar (in accordance with D.M. 24/11/84). A minimum distance of 1 m is only set for polyethylene pipes and for the separation from tramways (minimum horizontal distance 0,5 m and minimum vertical distance in the case of crossings of 1 m; 0,5 m if in a protection sheath)(UNI, 2004).

European Standard EN 12007-1 establishes that the pipeline operator should work to a set of minimum clearance distances for both parallel and crossing plants and sets guidelines for protective measures which should be taken in the case where lower clearance distances are required (CEN, 2000).

Some regulations regarding spacing between buried gas pipes and electrical services in force abroad are listed in Table 1.

Table 1 – Regulations regarding spacing between buried gas pipes and electrical services in force abroad

Country	Document	Requirements	Ref.
Australia	AS/NZS 5601	Separation of 100 mm if the electrical conduit or cable is mechanically protected; otherwise 300 mm	(Office of the Chief Electrical Inspector, 2003) and (Standards Australia, 2004)
USA Washington	Puget Sound Energy	12" (30 cm)	(Puget Sound Energy, 2006)
USA	Washington Gas Light Company	12" (30 cm)	(National Transportation Safety Board, 2001b)
USA Colorado	San Miguel Power Association	36" (91 cm)	(San Miguel Power Association, 2006)
Canada	SaskPower	60 cm	(SaskPower, 2004)

6. Discussion

The accident was caused by the fact that many cables and pipes were buried at a limited distance from each other, without any proper protection. With reference to Fig. 12, the electric fault, involving tram cable n. 7, a water pipe and a gas pipe occurred because:

- the gres protection pipe was not present where the power cable crossed the two pipes;
- the distance between the two pipes and the cable was nearly null;
- the tram cable was quite old (installed in 1956).

The gres protection pipe was missing because it had probably been damaged during previous works. The problem of damage to buried utilities during maintenance works not involving the utilities themselves is rather common; although standards and guidelines

exist that provide operative rules, they do not seem to be respected (Work Safe BC, 2005), (UNI, 1996).

Electric cables have a life of approximately 40 years; moreover, paper-oil insulated cables suffer from the “draining effect”, in particular with high and strongly changing loads (Pultrum *et al.*, 1998). Tram cable n. 7 was 50 years old when the accident occurred and tram networks typically have high and strongly changing loads. The substitution of electric cables after a certain number of years is not a common practice: only insulation tests are performed periodically (cable 7 was tested in June 2004).

The electric fault was not detected by the cable protections; this situation is common because, in traction systems, at the fault location the ground fault current is often lower than the setting of the circuit breakers. With the old circuit breaker models, the only settings were current values; in the new substations that feed the tram network, new circuit breakers are being installed, with more sophisticated relays. These relays also allow current derivative analysis to be made to distinguish between a fault and a normal operation current.

Actually, starting from a modest event (600 V electric cable loss of insulation), which most likely lasted for months, the accident was reached in a crescendo of domino effects. This sequence has been represented by an ISD in which the failure of the different protection systems is highlighted. These protection systems were mostly based upon the strict respect of procedures both in the installation and in the following maintenance of the different utilities.

Conclusions

The importance of the age of the distribution networks and the consequence of maintenance operations in the developing of faults emerged from the analysis of the accident here reported.

A periodical check of the cables insulation is probably not sufficient, and after a certain number of years (mean life) they should be substituted.

Accidents like the one described in this paper are not unusual; moreover, occurring in towns, where population densities are high, they produce a very high risk to the population. For this reason, a certain standardization of the rules regarding clearance distances between different buried utilities, and in particular between gas pipes and electric power cables, is desirable. In particular in Italy the introduction of a minimum clearance distance also for gas pipes with operating pressure up to 0,5 bar would be useful.

Fortunately, modern relays are being installed in Turin to improve fault detection in the tramway feeding network; this kind of relay should be installed in all traction systems.

Acknowledgements

The authors would like to thank C. Barbera (VVF), A. Marsigli and G. Dimilta (AES), T. Barbarino and Di Iulio (GTT) and M. Machetta (AEM) for their support in the accident analysis during the repairs to the utilities.

Acronyms

AC Alternated Current

AEM Azienda Energetica Metropolitana (Turin Power Distribution Company)

AES Azienda Energia e Servizi (Turin Gas Company)

AS Australian Standard

CEI Comitato Elettrotecnico Italiano (Italian Electrotechnical Committee)

CIG	Comitato Italiano Gas (Italian Gas Committee)
DC	Direct Current
DM	Decreto Ministeriale (Ministry Decree)
DN	Nominal Diameter
EN	European Norm
EPR	Ethylene Propylene Rubber
FT	Fault Tree
GTT	Gruppo Torinese Trasporti (Turin Tramway Network Company)
ISD	Incidental Sequences Diagram
LV	Low Voltage
MV	Medium Voltage
NG	Natural Gas
NZS	New Zealand Standard
PVC	Polyvinyl Chloride
TE	Top Event
UNI	Ente Nazionale Italiano di Unificazione (Italian National Unification Organization)
VVF	Vigili del Fuoco (Fire Brigade)

References

- Azcarraga, C.G. and Garcia-Colon, V.R., 2004, Assessing adequate spacing between directly buried automatic electrical and polyethylene gas distribution networks, *IEEE Power Engineering. LESCOPE-04. 2004 Conference on Large Engineering systems*: 151-155;
- Casal, J., Cisterò, J. and Tort, J.M., 1995, Some risks of energy distribution. Analysis of an explosion involving electrical and gas networks, *Loss prevention and Safety promotion in the process industries, Elsevier Science*, vol. I: 565-575;

- CEI, 1999, European Standard CEI EN 50122-2, "*Railway applications – Fixed installations – Part 2: Protective provisions against the effects of stray currents caused by d.c. traction systems*";
- CEI, 2006, Italian Standard CEI 11-17, "*Generation, transmission and public distribution systems of electric power – Cable lines*";
- CEI-UNI, 1998a, Italian Standard CEI UNI 70029, "*Underground multifunctioning tunnels and ducts for the coexistence of different networks – Design, construction, management and use – General and safety criteria*";
- CEI-UNI, 1998b, Italian Standard CEI UNI 70030, "*Buried technological installations – General criteria for laying*";
- CEN, 2000, European Standard EN 12007-1, "*Gas Supply systems – Pipelines for maximum operating pressure up to and including 16 bar – Part 1: General functional recommendations*";
- Demichela, M., Piccinini, N., Ciarambino, I. and Contini, S., 2004, How to avoid the generation of logic loops in the construction of fault trees, *Reliability Engineering & System Safety, Elsevier Science*, vol. 84, n 2: 197-207;
- Ministro dei Lavori Pubblici, 1999, Direttiva 3 Marzo 1999, "Razionale sistemazione nel sottosuolo degli impianti tecnologici", *G.U. n. 58 del 11-3-1999*, Italy;
- Ministro dell'Interno, 1984, DM 24/11/84 "Norme di sicurezza antincendio per il trasporto, la distribuzione, l'accumulo e l'utilizzazione del gas naturale con densità non superiore a 0,8", *G.U. 15 gennaio 1985, n. 12*, Italy;
- National Transportation Safety Board, 2001a, *Pipeline accident report: natural gas explosion and fire in south Riding, Virginia, July 7, 1998*, Washington D.C.;
- National Transportation Safety Board, 2001b, *Safety recommendation*, Washington D.C.
- Office of the Chief Electrical Inspector, 2003, *LEI Newsletter*, January/February, Australia;

Parker, T.J. and Ward, D.J., 2003, Insuring adequate spacing between underground distribution conductors in conduit and gas lines, *IEEE transactions on power delivery*, vol. 18, no.1:291-294;

Piccinini, N. and Ciarambino, I., 1997, Operability analysis devoted to the development of logic trees, *Reliability Engineering & System Safety, Elsevier Science*, vol. 55, n. 3: 227-241;

Puget Sound Energy, 2006, *Installation requirements for underground services*, Washington, USA;

Pultrum, E., Boone, W. and Steennis, E.F., 1998, Dutch distribution cable performance, *IEE Colloquium on "MV paper cables: asset or liability?"* Capenhurst, April 21;

San Miguel Power Association, 2006, *Construction handbook*, Colorado, USA;

SaskPower, 2004, *Electric Service Requirements*, Canada;

Standards Australia, 2004, AS 5601: Gas installations, Australia;

Tommasini, R., Rovera, N. and Pons, E., 2006, Sicurezza nei sistemi di alimentazione della rete tranviaria torinese, *Atti del convegno nazionale AEIT*;

UNI, 1996, Italian Standard UNI 10576, "Gas pipelines protection during underground works";

UNI, 2004, Italian Standard UNI 9165, "Gas Distribution Networks – Pipeworks with maximum operating pressure up to 5 bar – Design, construction, testing, operation, maintenance and rehabilitation";

Work Safe BC, 2005, *Prevention of damage to buried facilities in British Columbia*, Canada;