

Down-Sampled Impulse Response Least-Squares Channel Estimation for LTE OFDMA

Original

Down-Sampled Impulse Response Least-Squares Channel Estimation for LTE OFDMA / Ancora, A; Bona, Calogero; Slock, D. T. M.. - 3:(2007), pp. 293-296. (Intervento presentato al convegno Acoustics, Speech and Signal Processing, 2007. ICASSP 2007. tenutosi a Honolulu nel 15-20 April 2007).

Availability:

This version is available at: 11583/1954552 since:

Publisher:

IEEE

Published

DOI:

Terms of use:

This article is made available under terms and conditions as specified in the corresponding bibliographic description in the repository

Publisher copyright

(Article begins on next page)

DOWN-SAMPLED IMPULSE RESPONSE LEAST-SQUARES CHANNEL ESTIMATION FOR LTE OFDMA

Andrea Ancora, Calogero Bona

NXP Semiconductors
Business Line Cellular Systems
505, route des Lucioles
06560 Sophia Antipolis, France
{andrea.ancora, calogero.bona}@nxp.com

Dirk T.M. Slock

EURECOM Institute
Mobile Communications Dept.
2229, route des Crêtes
06904 Sophia Antipolis, France
dirk.slock@eurecom.fr

ABSTRACT

We consider Least-Squares (LS) downlink channel estimation for LTE OFDMA receivers. The 3GPP Long Term Evolution (LTE) project aims at continuing the competitiveness of the 3GPP standard reached with HSPA. OFDMA was chosen as multiple-access scheme for the downlink and 10 MHz bandwidth is the minimum capability for User Equipments (UE). In such a context, an ill conditioning problem of the classical LS approach was found due to the un-excitation of a large portion of available sub-carriers of the LTE OFDMA symbol (due to the guard band). Two methods are investigated and compared to solve this problem: the first solution is regularization and the second one is down-sampling of the channel impulse response. The latter solution proves to perform better and allows some computational savings.

Index Terms— OFDMA, channel estimation, least-squares, LTE, guard band

1. INTRODUCTION AND BACKGROUND

The Third Generation Partnership Program (3GPP) members started in December 2004 a feasibility study on the enhancement of the Universal Terrestrial Radio Access (UTRA) in the aim of continuing the long time frame competitiveness, i.e. for the next 10 years and beyond, of the 3G technologies already reached with HSPA (High Speed Packet Access). This project was called Evolved-UTRAN or Long Term Evolution.

OFDMA was chosen as multiple-access scheme for the downlink [1]. The discrete-time OFDMA transceiver model is represented in Figure 1. The N complex constellation symbols a_i are modulated on the N orthogonal sub-carriers spaced out by Δf_c (15 kHz) by mean of the Inverse Discrete Fourier Transform (IDFT) resulting in an N long sequence corresponding to the time-domain representation of the transmitted OFDMA symbol. In order to avoid Inter Symbol Interference (ISI) the last CP transmitted symbols are copied and appended to exploit the circular property of the Discrete Fourier

Transform (DFT). The length CP is assumed to be longer than the channel delay spread. In LTE two cyclic prefixes are considered: a short one of duration $4.7 \mu s$ and a long one of $16.7 \mu s$; in the following only the short cyclic prefix length is considered. The sequence obtained is serialized leading to the $s(k)$ sequence and transmitted over the discrete time channel with a sampling rate T_s equal to the inverse of the sampling frequency $N\Delta f_c$. At the receiver side, the $r(k)$ sequence, resulting from the sum of the transmitted signal passed through the channel and the complex circular additive white gaussian noise $w(k)$ with distribution $\mathcal{N}_C(0, \sigma_w^2)$, is collected. Then, the cyclic prefix samples are discarded and the remaining N samples are processed by the DFT to retrieve the complex constellation symbols transmitted over the orthogonal sub-channels. This scheme is trivially scalable increasing the size of the IDFT/DFT blocks and keeping the sub-carrier spacing constant. In Table 1, the transmission scheme parameters of the LTE system are shown. With a DFT size ranging from 128 to 2048, the total downlink bandwidth is scaled from 1.25 MHz to 20 MHz. In the following, without loss of generality of the results provided, we will refer to a 10 MHz bandwidth system.

As shown in Figure 2, the LTE sub-frame is composed of 7 OFDMA symbols and, according to table 1, in each OFDMA symbol only $N_m - 1$ sub-carriers over N are modulated (the sub-carrier corresponding to DC of the baseband signal is not modulated) when the remaining sub-carriers on the edges are left unmodulated as a guard band.

Two pilots sequences embedded in the LTE frame are interleaved with the data samples in the first and the fifth symbols of the sub-frame. These pilots, uniformly spaced out by 5 samples, are intended for channel estimation.

The time domain received signal can be represented in a matrix form as:

$$\mathbf{r} = \mathbf{F}^H \mathbf{A} \mathbf{F}_L \mathbf{h} + \mathbf{w} \quad (1)$$

- \mathbf{h} is the $L \times 1$ vector corresponding to the FIR representation of the channel in the time domain;

- \mathbf{F}_L is the $N \times L$ Fourier matrix that gives the frequency domain representation over N sub-carriers of the channel of length L ;
- \mathbf{A} is the $N \times N$ diagonal matrix containing, in the positions corresponding to the modulated sub-carriers (N_m over N), the transmitted symbols (comprising both data and pilot) in the frequency domain, assumed to be transmitted with the same energy;
- \mathbf{F}^H is the $N \times N$ inverse Fourier matrix giving the time domain representation of the received signal;
- \mathbf{w} is the $N \times 1$ vector corresponding to the complex circular additive white gaussian noise distributed as $\mathcal{N}_C(0, \sigma_w^2 \mathbf{I}_N)$.

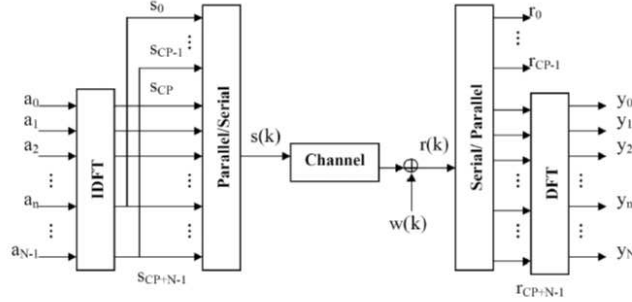

Fig. 1. LTE OFDMA transceiver.

2. LEAST SQUARE CHANNEL ESTIMATION

From eq. (1), the received signal in the time domain can be equivalently written as:

$$\mathbf{r} = \mathbf{S}\mathbf{h} + \mathbf{w} \quad (2)$$

where

$$\mathbf{S} = \mathbf{F}^H \mathbf{A} \mathbf{F}_L \quad (3)$$

and the diagonal matrix \mathbf{A} containing the complex symbols modulated over the sub-channels can be expressed as:

$$\mathbf{A} = \mathbf{A}_d + \mathbf{A}_p \quad (4)$$

where \mathbf{A}_d and \mathbf{A}_p are again two $N \times N$ diagonal matrices containing non-zero elements in the positions of the transmitted data and of the transmitted pilot symbols respectively. \mathbf{w} is the $N \times 1$ vector representing the circular complex additive white Gaussian noise with distribution $\mathcal{N}_C(0, \sigma_w^2 \mathbf{I}_N)$.

As the transmitted data are unknown, we consider an approximation of the matrix \mathbf{S} where only the pilot symbols are taken into account:

$$\mathbf{S} \approx \mathbf{F}^H \mathbf{A}_p \mathbf{F}_L \quad (5)$$

The channel \mathbf{h} can be estimated by means of the Least Squares (LS) criterion [2], whose expression is given by:

$$\hat{\mathbf{h}} = (\mathbf{S}^H \mathbf{S})^{-1} \mathbf{S}^H \mathbf{r} \quad (6)$$

where the channel is considered as a deterministic parameter and no knowledge on its statistics and on the noise is needed.

Substituting (5) into (6), a simplified formulation of the LS estimator is obtained:

$$\hat{\mathbf{h}} \approx (\mathbf{F}_L^H \mathbf{A}_p^H \mathbf{A}_p \mathbf{F}_L)^{-1} \mathbf{F}_L^H \mathbf{A}_p^H \mathbf{F}^H \mathbf{r} \quad (7)$$

The LS estimator is computationally simple as the whole matrix

$$(\mathbf{F}_L^H \mathbf{A}_p^H \mathbf{A}_p \mathbf{F}_L)^{-1} \mathbf{F}_L^H \quad (8)$$

is constant. In practice, the matrix inversion can be computed off-line and used regardless of the varying channel statistics.

A serious problem that is encountered in the straight application of the LS estimator is that the inversion of the $L \times L$ matrix turns out to be ill conditioned.

We consider two solutions to this problem.

2.1. Regularized LS channel estimation

The first solution is to regularize the eigenvalues of the matrix to be inverted by adding a small constant term to the diagonal. Modifying (6) accordingly, we obtain the *regularized LS channel estimation* expression:

$$\hat{\mathbf{h}}_{\text{reg}} = (\alpha \mathbf{I} + \mathbf{F}_L^H \mathbf{A}_p^H \mathbf{A}_p \mathbf{F}_L)^{-1} \mathbf{F}_L^H \mathbf{A}_p^H \mathbf{F}^H \mathbf{r} \quad (9)$$

where α has to be chosen such that the resulting eigenvalues are all defined and the matrix $(\alpha \mathbf{I} + \mathbf{F}_L^H \mathbf{A}_p^H \mathbf{A}_p \mathbf{F}_L)^{-1}$ is the least perturbed.

2.2. Down-sampled impulse response LS channel estimation

The second solution is found realizing that the ill-conditioning problem comes from the un-excitation of a large portion of the band due the LTE OFDM symbol structure. Considering for example the case of a symbol size N equal to 1024 from Table 1, the number of modulated sub-carriers is only 600. Hence, while the sampling frequency is 15.36 MHz ($N \Delta f_c$), the excited (used) band-width is only 9 MHz ($N_m \Delta f_c$).

If the channel can be sounded only in the excited band, the *numerical bandwidth* (the ratio between the occupied bandwidth and the sampling frequency) can be increased to a somewhat slight smaller value than 1. This can be done, for example, by decreasing the sampling frequency by a factor of 2/3 which still ensures the absence of aliasing as the resulting sampling frequency is 10.24 MHz. Practically, the channel \mathbf{h} is not estimated in all the L taps but only in 2 out of 3 taps (obtaining the average downsampling factor 2/3) and setting to 0 the discarded ones:

Frame duration [ms]	0.5					
Sub-carr. spacing [kHz]	15					
Transm. BW [MHz]	1.25	2.5	5	10	15	20
Sampling freq. [MHz]	1.92	3.84	7.68	15.36	23.04	30.72
FFT size	128	256	512	1024	1536	2048
Occupied sub-carr.	76	151	301	601	901	1201

Table 1. LTE OFDMA parameters.

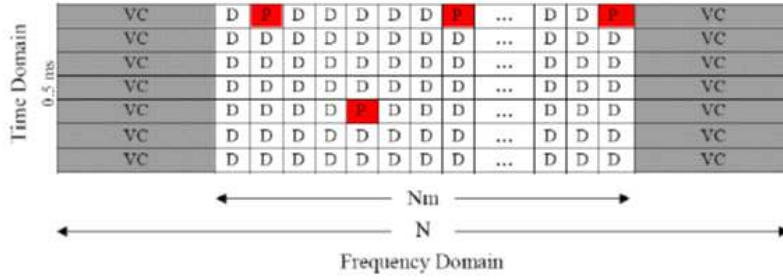

Fig. 2. LTE OFDMA frame structure.

$$\bar{\mathbf{h}} = (h_0 \ h_1 \ 0 \ h_3 \ h_4 \ 0 \ \dots \ h_{L-1})^T \quad (10)$$

As the OFDMA channel equalization is performed in the frequency domain, it does not matter to have an exact time domain representation of the channel at the actual sampling frequency. What is only important is the channel transfer function in the band of interest:

$$\mathbf{H} = \mathbf{F}_L \bar{\mathbf{h}} = \begin{bmatrix} 1 & 1 & 1 & 1 & 1 \\ 1 & w^1 & w^2 & \dots & w^{(L-1)} \\ 1 & w^2 & w^3 & \dots & w^{2(L-1)} \\ 1 & w^3 & w^6 & \dots & w^{3(L-1)} \\ 1 & w^4 & w^8 & \dots & w^{4(L-1)} \\ 1 & w^5 & w^{10} & \dots & w^{5(L-1)} \\ \vdots & \vdots & \vdots & \vdots & \vdots \\ 1 & w^{N-1} & w^{2(N-1)} & \dots & w^{(L-1)(N-1)} \end{bmatrix} \begin{bmatrix} h_0 \\ h_1 \\ 0 \\ h_3 \\ h_4 \\ 0 \\ \vdots \\ h_{L-1} \end{bmatrix} \quad (11)$$

$$\mathbf{H} = \mathbf{F}_L^{DS} \mathbf{h}^{DS} = \begin{bmatrix} 1 & 1 & 1 & 1 & 1 \\ 1 & w^1 & w^3 & \dots & w^{(L-1)} \\ 1 & w^2 & w^6 & \dots & w^{2(L-1)} \\ 1 & w^3 & w^9 & \dots & w^{3(L-1)} \\ 1 & w^4 & w^{12} & \dots & w^{4(L-1)} \\ 1 & w^5 & w^{15} & \dots & w^{5(L-1)} \\ \vdots & \vdots & \vdots & \vdots & \vdots \\ 1 & w^{N-1} & w^{3(N-1)} & \dots & w^{(L-1)(N-1)} \end{bmatrix} \begin{bmatrix} h_0 \\ h_1 \\ h_3 \\ h_4 \\ \vdots \\ h_{L-1} \end{bmatrix} \quad (12)$$

$$w = e^{j \frac{2\pi}{N}} \quad (13)$$

As shown by (11) and (12), this approach turns out to be as if, in the received signal representation given by (1), the $\frac{L}{3}$ columns of the Fourier matrix \mathbf{F}_L corresponding to the neglected taps are multiplied by 0, so the time domain received signal can be represented as:

$$\mathbf{r} = \mathbf{F}^H \mathbf{A} \mathbf{F}_L^{DS} \mathbf{h}^{DS} + \mathbf{w} \quad (14)$$

where \mathbf{h}^{DS} is the downsampled version of the FIR channel representation with the resulting vector length $\frac{2}{3}L$. Analogously \mathbf{F}_L^{DS} is equal to the Fourier matrix \mathbf{F}_L where the columns corresponding to the removed taps of h are removed.

Again, the LS criterion can be applied to obtain the *downsampled LS channel estimation* expression:

$$\hat{\mathbf{h}}_{ds} = (\mathbf{F}_L^{DS,H} \mathbf{A}_p^H \mathbf{A}_p \mathbf{F}_L^{DS})^{-1} \mathbf{F}_L^{DS,H} \mathbf{A}_p^H \mathbf{F} \mathbf{r} \quad (15)$$

Using the Fourier matrix corresponding to the downsampled channel, the ill conditioning problem is solved and furthermore a complexity gain is obtained because the size of the matrix $(\mathbf{F}_L^{DS,H} \mathbf{A}_p^H \mathbf{A}_p \mathbf{F}_L^{DS})^{-1} \mathbf{F}_L^{DS,H}$ turns out to be $\frac{2}{3}L \times N$.

3. SIMULATION RESULTS

In figures 3 and 4, the real parts of the transfer functions of the estimated channel using both methods are shown (the results for the imaginary parts are similar and then are omitted). It can be seen that in this case the first method gives a proper estimation over the whole band whereas the second one gives the same results only in the band of interest (the 600 central sub-carriers).

In figure 5 the curves referring to the MSE normalized with respect to the channel energy of the two solutions (the

downsampled and the regularized) of the LS channel estimator are plotted. The channel to be estimated was assumed to be a 6 paths Vehicular A WINNER channel [3], the bandwidth of the system was 10 MHz corresponding to a sampling frequency of 15.36 MHz resulting in an equivalent channel length of 28 taps which was assumed to be perfectly known. The performance of the downsampled LS channel estimation is 0.5 dB better because the same number of pilots are used to estimate less taps.

4. CONCLUSIONS

In this paper we provided a novel method to solve the problem of the ill-conditioning of the classical Least Squares Channel Impulse Response estimation approach within the specific framework of the LTE OFDMA.

We showed that in such a system, provided that the Nyquist criterion is satisfied, downsampling can be performed without loss of information.

The resulting Down-Sampled Impulse Response Least Squares Channel Estimation leads to a well-conditioned problem in the useful band-width with a consequent performance improvement while reducing the computational complexity.

5. REFERENCES

- [1] 3GPP WG1, "Tr 25.814: Physical layer aspects for e-utra (rel. 7)," *www.3gpp.org*, p. 126, 2006.
- [2] J.-J. van de Beek et al., "On channel estimation in ofdm systems," *Vehicular Technology Conference*, vol. 2, pp. 815–819, Jul 1995.
- [3] 3GPP WG4, "Tr 25.996: Spatial channel models for mimo simulations," *www.3gpp.org*, 2006.

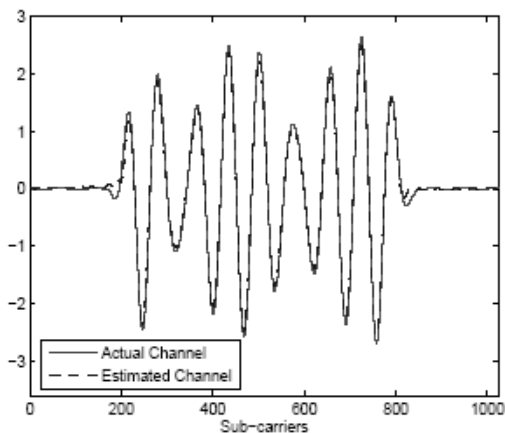

Fig. 3. Estimated channel transfer function by regularization.

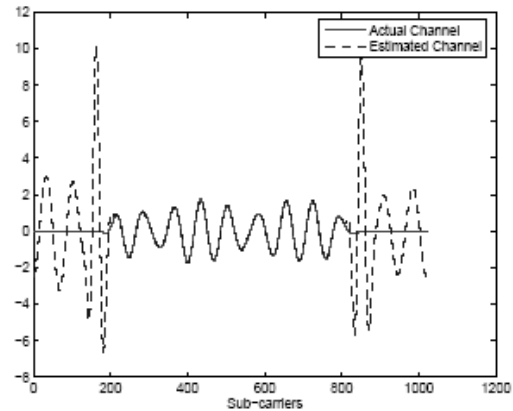

Fig. 4. Estimated channel transfer function by downsampling.

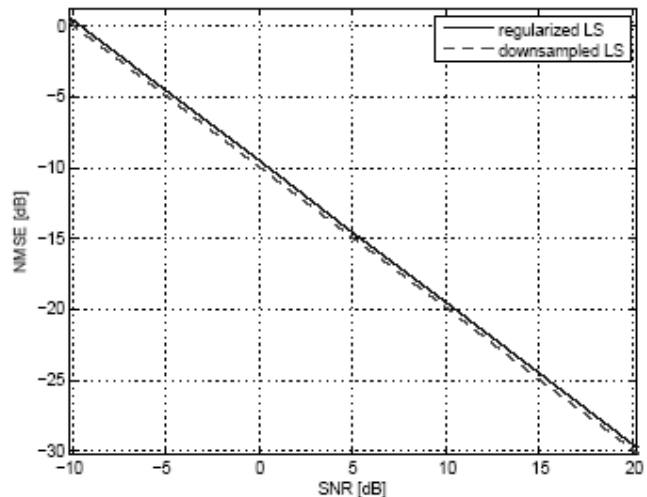

Fig. 5. Normalised MSE of the CIR estimate.