

WONDER: A PON over a Folded Bus

*Original*

WONDER: A PON over a Folded Bus / Bianco, Andrea; Cuda, Davide; Finochietto, J; Neri, Fabio; Valcarengi, M.. - STAMPA. - (2008), pp. 1-5. (Intervento presentato al convegno IEEE GLOBECOM tenutosi a New Orleans, USA nel DECEMBER 2008) [10.1109/GLOCOM.2008.ECP.499].

*Availability:*

This version is available at: 11583/1906420 since:

*Publisher:*

IEEE

*Published*

DOI:10.1109/GLOCOM.2008.ECP.499

*Terms of use:*

This article is made available under terms and conditions as specified in the corresponding bibliographic description in the repository

*Publisher copyright*

(Article begins on next page)

# WONDER: a PON over a Folded Bus

Andrea Bianco, *Member, IEEE*, Davide Cuda, *Student Member, IEEE*, Jorge M. Finochietto, *Member, IEEE*, Fabio Neri, *Member, IEEE*, and Marco Valcarenghi

**Abstract**—Passive Optical Networks (PONs) represent a step forward in “first mile” networks; indeed, by using optical technologies, PONs can transfer a large amount of data, and by being completely passive, they reduce management costs and failure probabilities. Access network is logically a point-to-multipoint network and the tree topology emerged as the winning solution; however, it naturally lacks protection capability and requires local traffic to be processed by the Optical Line Terminal. In this paper, we present WONDER, a novel PON architecture based on a folded bus topology, which offers fault resilience and efficient local traffic support, and we discuss WONDER strengths and weaknesses.

## I. INTRODUCTION

The strong interest in Passive Optical Networks (PONs) is justified by the increase in Internet traffic due to the introduction of new bandwidth-intense applications, such as video or peer-to-peer (P2P) file sharing, which are rapidly exhausting access network resources. Both Digital Subscriber Line (DSL) and Cable TV (CATV) solutions present physical limitations and performance limitations, being originally designed for analog traffic and not for data traffic.

Recently, PONs attracted telecom operator attention. Indeed, by providing large bandwidth, large span cover and low maintenance costs, PONs represent a significant step forward in “first mile” networks. Indeed, the transition to fiber-supported access seems quite inevitable worldwide. Nowadays, two Time-Division Multiple Access (TDMA) PON variants are being used for mass roll-out: Gigabit PON (GPON) [1], primarily in Europe and USA, and Ethernet PON (EPON) [2], primarily in Japan and Korea.

Efficient PON design represents a challenging topic for both academia and industry. PONs are Point-to-MultiPoint (P2MP) access networks. Indeed, they offer today a multiplexed downstream channel and a multiple-access upstream channel to support traffic from/to the Optical Line Terminal (OLT) and users. In the downstream direction, data are broadcasted by the OLT and selectively received by the users connected to an Optical Network Unit (ONU). In the upstream direction, ONUs have to share the medium; thus, an arbitration mechanism to avoid collisions and fairly share the fiber-channel capacity is needed. The OLT is usually responsible for keeping all the ONUs synchronized and for allocating ONUs transmission slots running a Dynamic Bandwidth Allocation (DBA) algorithm.

Several physical topologies like tree, ring or bus are suitable for access networks, but in the PON scenario the tree architecture is largely dominant and it is the preferred topology

This work was partially supported by the Networks of Excellence e-Photon/ONe and BONE (“Building the future Optical Network in Europe”), funded by the European Commission through the 6<sup>th</sup> and 7<sup>th</sup> Framework Programmes.

for both EPON and GPON. Indeed, the tree topology presents some advantages, like simplicity and minimum power losses, but it is prone to problems like lack of protection and no efficient support of ONU-to-ONU communication, since OLT processing is always required. Full protection can be achieved only with “1+1” schemes, i.e., only by deploying an additional backup trunk and branches following different paths, leading to additional deployment costs.

In this paper, we propose a different architecture, named WONDER, previously studied as a metro network architecture [3]. We show how WONDER can be exploited as a PON and we compare its performance to tree, bus and ring based PONs.

## II. WONDER ARCHITECTURE

WONDER was conceived in the context of an Italian research project aimed at finding an effective solution for bridging the gap between future access networks and backbone ones [4]. The WONDER architecture is shown in Fig. 1, while the node structure is illustrated in Fig. 2.

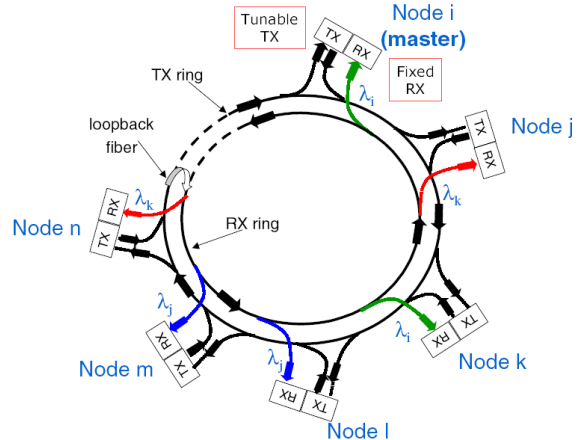

Fig. 1. WONDER network architecture

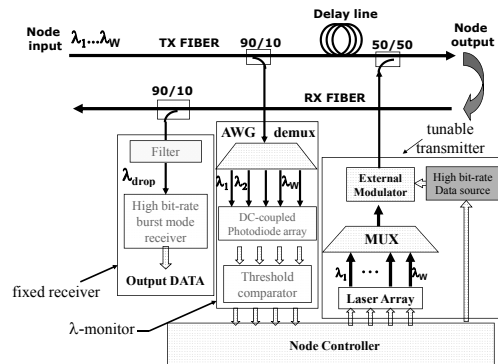

Fig. 2. WONDER node structure

WONDER comprises  $N$  nodes connected to two counter-rotating WDM fiber rings. Each ring conveys  $W$  wavelengths,

( $N \geq W$ ), and it is used in a peculiar way: one ring is used for transmission only, while the other ring is used for reception only. Transmission wavelengths are switched to the reception ring at a folding point between the two rings, as shown in Fig. 1. Transmitted packets cross the transmission ring until they reach the folding point, where they are switched to the reception ring and received during the second ring traversal. Thus, the architecture behaves as a folded bus network.

The network is synchronous and time-slotted. During a time slot, at most one packet can be transmitted by a node in one of the  $W$  available slots (one slot for each wavelength channel). Each node is equipped with a fixed Burst Mode Receiver (BMR), tuned to  $\lambda_{\text{drop}}$  as shown in Fig. 2; given that  $N \geq W$ , receivers can be allocated to WDM channels to equalize the traffic across WDM channels (see [5]). To provide full connectivity between nodes, each node is equipped with a fast tunable transmitter, which is tuned to the receivers destination wavelength, establishing a single hop connection lasting one time slot. The channel resource sharing is therefore achieved according to a TDMA scheme. Access decisions are based on a channel inspection capability called  $\lambda$ -monitor (Fig. 2) to avoid collisions, i.e., access to an already used slot.

### III. WONDER AS A PON

Since WONDER has no active elements along the signal path, it is a PON. Note that WONDER features unidirectional transmission on two separate fibers, while often standard PONs operate with bidirectional transmission over a single fiber.

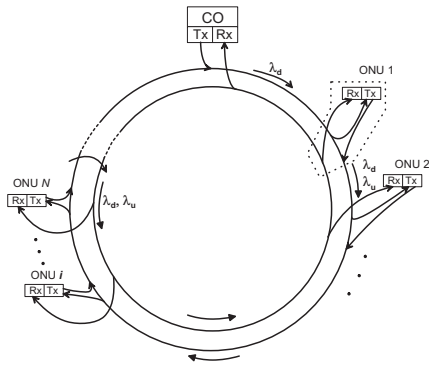

Fig. 3. WONDER as a PON

Fig. 3 shows how the WONDER architecture can be employed as a PON. The Central Office (CO) is located at the beginning of the folded bus. The CO node acts as OLT, while the other nodes, as ONUs. Considering network resources, WONDER exploits one wavelength for downstream transmission ( $\lambda_d$ ) and one wavelength for upstream transmission ( $\lambda_u$ ). To separate and receive data, both ONUs and the CO require a filter, tuned on  $\lambda_d$  and  $\lambda_u$ , respectively. With respect to the original WONDER node [3], ONUs do not require a BMR and can be equipped with a fixed instead of a tunable laser.

WONDER can employ a centralized access protocol, as the Multi-Point Control Protocol (MPCP) of EPONs [2] or the media access control described in the GPON Transmission Convergence (GTC) layer [6]. Furthermore, a distributed access and fairness control protocol as the one proposed for the

original network (see [7]) can be adopted with limited extra complexity. If a centralized scheme is used, i.e., if all decisions are taken by the OLT, the carrier sense mechanism is no longer required and taps can be eliminated. Finally, if the WONDER distributed access scheme is employed, each ONU can reach any other ONU without passing through the CO.

If each ONU is equipped with optical switches (OSW) which are used to fold the terminal point of the bus (see [3] for details), WONDER shows interesting fault recovery properties. Indeed, if there is a fiber cut, each ONU can shortcut the two fibers, restoring the folded bus, thus, keeping the network in operation (Fig. 4). Efficient fault recovery strategies were studied and analyzed [8].

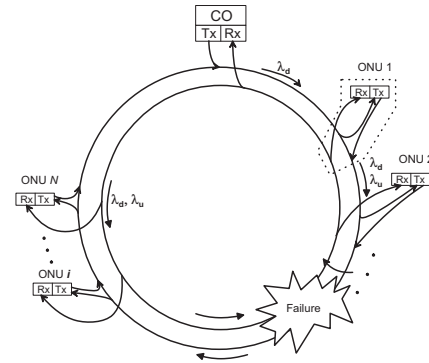

Fig. 4. WONDER behavior when a fiber cut occurs

To improve WONDER scalability in number of ONUs, power losses along the ring should be reduced. This can be obtained by grouping ONUs in sets (see Fig. 5) to reduce the number of couplers the optical signal has to pass through. We call this solution Grouped WONDER (GW). If this configuration is adopted, the carrier sense line has to be decoupled from the transmission line to avoid any possible signal interference, and a suitable delay line has to be used to keep slot alignment.

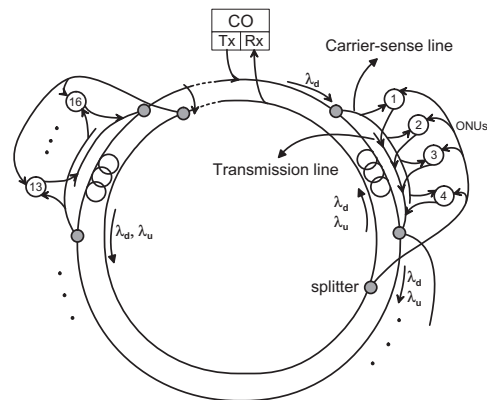

Fig. 5. Grouped WONDER (GW) architecture

However, when grouping the nodes, WONDER loses its fault recovery property since ONUs are no longer directly attached to the folded bus and cannot use the OS to fold the bus around the fault in case of link failure. To partially restore the fault recovery property, we can introduce a Folding Element (FE) node between ONUs groups, as shown in Fig. 6. A FE node is composed by two optical switches, two taps and a node controller. The FE node controller checks the optical

signal by means of optical taps, and decides if the bus has to be folded or not. Nevertheless, the fault recovery capability is guaranteed only between ONU groups and not among ONUs belonging to the same group.

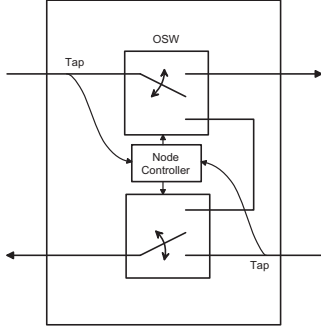

Fig. 6. Folding Element (FE) node

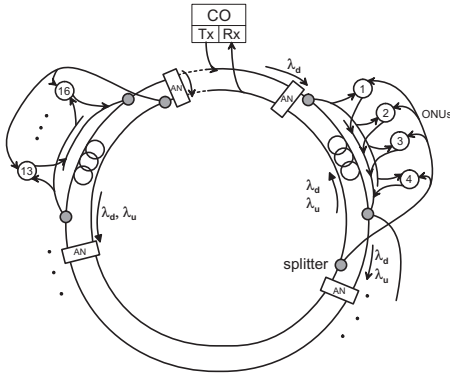

Fig. 7. WONDER architecture with Folding Elements (FE)

#### IV. PERFORMANCE ANALYSIS

Current PON solutions are almost always deployed over a tree topology, but they can be also implemented over different physical topologies, such as buses and rings [9]. In the bus architecture, the CO is placed at the beginning of the bus and the ONUs are attached to the shared medium by means of 1:2 couplers. Due to optical splitter properties, transmission between ONUs has to go through the CO. In a ring architecture each ONU is attached to the medium either by a 2:2 optical star-coupler (ONUs require a fixed filter to decouple upstream from downstream data) or by a 2×1:2 splitters. Rings support both uni-directional and bi-directional transmission but, in the last case, a double transceiver is required both at the ONUs and the CO. In both bus and ring architectures, ONUs can be grouped reducing the power budget limitations as in the GW architecture. The Grouped Bus (GB) and the Grouped Ring (GR) architectures are shown in Fig. 8 and Fig. 9 respectively.

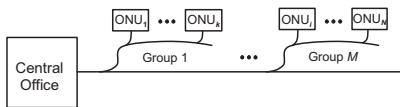

Fig. 8. Grouped Bus (GB) architecture

In the following, to compare WONDER to classical PON solutions, we use *local traffic*, *reliability* and *power budget* as performance indicators.

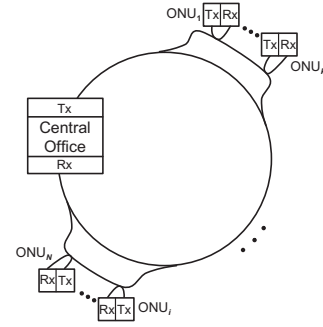

Fig. 9. Grouped Ring (GR) architecture

#### A. Local Traffic

PONs originated as access networks and their main objective is to provide centralized services to remote users. Traffic has therefore mainly a P2MP nature (from/to CO to/from ONUs). However, this may not always be the case, for example, if the network is used in a university campus or in a business environment or when considering P2P applications. Thus, an efficient mechanism to support local (ONU to ONU) traffic exchange may be useful. Because of splitter and coupler directional properties, both in a tree and in a bus architecture, when ONU<sub>i</sub> has traffic destined to ONU<sub>j</sub> it must pass through the CO. In a ring or in WONDER, two ONUs can communicate directly without involving the CO, thereby reducing CO costs.

We can evaluate the impact of local traffic considering how long local traffic occupies network resources: the trip delay (TD), defined as the time required to send one bit between a pair of ONUs can be taken as a good performance index. For this purpose, we adopt the following notation:

$N$	number of ONUs
$r$	ONU – OLT distance
$P_d$	light propagation delay, equal to $5 \mu s/Km$
$T_c$	processing time to run the DBA algorithm at the OLT
$\bar{D}$	average trip delay
$D$	worst case trip delay
$d_i$	trip delay between ONU <sub>i</sub> and OLT

Traffic performance depends on ONU position; thus, we consider both worst and average case analysis. To fairly compare different topologies performance, we consider that ONUs are uniformly placed along a circle of radius  $r$ . For the tree architecture, we consider the OLT placed in the middle of the circle; thus all ONUs are at the same distance  $r$  from the OLT. In the bus, ring and WONDER case, OLT is placed at the beginning of the fiber and ONUs are uniformly distributed along a fiber of length  $2\pi r$ .

Let observe that  $d_i = rP_d$  for the tree architecture, while  $d_i = \frac{2\pi r}{N+1} i P_d$  for the other architectures. Both in the bus and in the tree architecture, the communication between ONU<sub>i</sub> and ONU<sub>j</sub> has to pass through the CO. Thus, the average trip delay becomes:

$$\bar{D}_{\text{bus/tree}} = \frac{1}{N} \sum_{i=1}^N \frac{1}{N-1} \sum_{\substack{j=1 \\ j \neq i}}^N (d_i + T_c + d_j)$$

The worst trip delay happens when ONU<sub>N</sub> wants to communicate with ONU<sub>N-1</sub>, i.e.  $D_{\text{bus/tree}} = d_N + T_c + d_{N-1}$

TABLE I

WORST AND AVERAGE DELAYS FOR DIFFERENT PON ARCHITECTURES

Architecture	Worst Delay ( $D$ ) [ms]		Average Delay ( $\bar{D}$ ) [ms]	
	$N = 16$	$N = 32$	$N = 16$	$N = 32$
Tree	$0.2 + T_c$	$0.2 + T_c$	$0.2 + T_c$	$0.2 + T_c$
Bus	$1.1 + T_c$	$1.2 + T_c$	$0.628 + T_c$	$0.628 + T_c$
Ring	$0.591 + T_c$	$0.609 + T_c$	$0.589 + T_c$	$0.608 + T_c$
WONDER	1.1	1.2	0.5544	0.5902

(Notice that, in the case of the tree architecture, due to our settings,  $d_i = d_j \forall i, j$ ). In the case of a unidirectional ring PON, because of the optical splitter properties and its physical topology,  $ONU_i$  can reach all the downstream nodes without passing through the CO, while the CO help is required to reach all previous upstream nodes. Therefore, the average trip delay can be decomposed in two equations:

$$\bar{D}_{ring,d} = \frac{1}{N} \sum_{i=1}^{N-1} \frac{1}{N-i} \sum_{j=i+1}^N (d_j - d_i) \quad j > i$$

$$\bar{D}_{ring,u} = \frac{1}{N} \sum_{i=2}^N \frac{1}{i-1} \sum_{j=1}^{i-1} (2\pi r P_d - d_i + T_c + d_j) \quad j < i$$

The worst case scenario happens when  $ONU_2$  wants to communicate with  $ONU_1$ , i.e.,  $D_{ring} = 2\pi r P_d - d_2 + T_c + d_1$ .

In WONDER, the communication between two nodes does not require the CO help and the average trip delay is:

$$\bar{D}_{WONDER} = \frac{1}{N} \sum_{i=1}^N \frac{1}{N-1} \sum_{\substack{j=1 \\ j \neq i}}^N (d_N - d_i + d_N - d_j)$$

The worst case occurs when  $ONU_1$  wants to communicate with  $ONU_2$  and the trip delay becomes  $D_{WONDER} = 2d_N - d_1 - d_2$ .

Table I shows worst and average delays for different PON architectures when  $r = 20$  km. WONDER is the only architecture in which the delay is not dependent on the computation time required at the CO if a distributed access scheme is implemented. The average WONDER trip delay is similar to the bus and the ring values. The tree architecture shows the lowest values for the worst and average delay among the architectures depending on  $T_c$ , which is not easy to estimate. In the considered setup, WONDER shows better performance when  $T_c > 0.39$  ms.

### B. Reliability

We analyze reliability properties of the different PON architectures; we utilize the Reliability Block Diagram (RBD), used in [9], [10]. The RBD is made up of individual blocks and each block corresponds to a system module or function. Blocks are connected through series and parallel relationships. Let be the unavailability the probability a block fails; thus, given the steady-state unavailability of each block, we can derive the steady-state unavailability of series and parallel blocks [11].

The RBD of the tree and the bus architectures is depicted in Fig. 10. We evaluate unavailability using the same technique proposed in [9]. We consider a single fault scenario. The CO group consists of a trunk fiber, a CO transmitter and a CO receiver, while ONU blocks are formed by a branch fiber, a

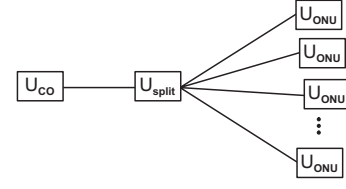

(a) Tree RBD

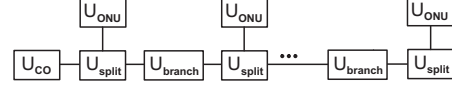

(b) Bus RBD

Fig. 10. Reliability Block Diagrams (RBD) for tree and bus architectures

ONU transmitter, and a ONU receiver. The unavailability of these groups becomes:

$$U_{CO} = 1 - (1 - U_{CO,Tx})(1 - U_{CO,Rx})(1 - U_{trunk})$$

$$U_{ONU} = 1 - (1 - U_{ONU,Tx})(1 - U_{ONU,Rx})(1 - U_{branch})$$

The unavailability of a specific architecture is the mean unavailability of the connections between CO and ONUs. Thus, the tree architecture unavailability is given by:

$$U_{tree} = 1 - (1 - U_{CO})(1 - U_{split})(1 - U_{ONU})$$

In a bus architecture, each node has a different connection with the CO. Thus, the unavailability of the connection between  $ONU_i$  and the CO is given by:

$$U_i = 1 - (1 - U_{CO})(1 - U_{split})^i(1 - U_{branch})^{i-1}(1 - U_{ONU})$$

The ring unavailability can be considered equal to the bus unavailability because the ring is unidirectional and both architectures employ the same type and number of devices. Thus, the average ring/bus unavailability is equal to:

$$U_{ring/bus} = \frac{1}{N} \sum_{i=1}^N U_i$$

Due to the fault recovery mechanism (Sec. III), WONDER unavailability simply depends on CO and ONUs unavailability:

$$U_{CO} = 1 - (1 - U_{CO,Tx})(1 - U_{CO,Rx})(1 - U_{split,CO})^2$$

$$U_{ONU} = 1 - (1 - U_{ONU,Tx})(1 - U_{ONU,Rx})(1 - U_{split,ONU})^2$$

Thus, the WONDER unavailability is:

$$U_{WONDER} = 1 - (1 - U_{CO})(1 - U_{ONU})$$

Table II compares the service unavailability and the expected downtime (the downtime is the product between unavailability and the number of minutes in a year) per ONUs for different PON architectures. Network component unavailability values are taken from [9].

As expected, bus and ring architectures show the worst reliability performance.

TABLE II

UNAVAILABILITY AND EXPECTED DOWNTIME FOR DIFFERENT PONs

Architecture	Unavailability (U)	Expected downtime [min/yr]
Bus/Ring <sup>1</sup>	$2.40 \times 10^{-4}$	126.08
Unprotected tree	$7.56 \times 10^{-5}$	39.72
WONDER	$2.81 \times 10^{-5}$	14.76

TABLE III

GPON AND EPON POWER BUDGET VALUES

Standard	GPON		EPON
	Class B	Class B+	PX20
Downstream PB [dB]	21	27	23.5
Upstream PB [dB]	28	28	24

### C. Power Budget

The power budget is defined as the optical power that can be lost by optical signals along the path between the CO and the ONUs. It is one of the biggest PON limiting factors and deeply affects network scalability. The power budget of the tree architecture is dominated by the splitter/combiner located between the CO and the ONUs, while the power budget of the bus and the WONDER architectures is dominated by the couplers used to attach each ONU to the shared medium. We perform a numerical analysis considering the insertion loss (IL) of optical components. Optical 1 : 2 couplers have an ideal insertion loss ( $IL_c$ ) of 3 dB. Since 1 :  $N$  optical splitters can be considered as composed by several 1 : 2 3dB-couplers, their insertion loss ( $IL_{split}$ ) is  $\log_2(N) \times IL_c$ . Under these assumptions, the power budget of the bus and the ring architectures is  $N \times IL_c$ , the power budget of the WONDER architecture is  $2N \times IL_c$  and the power budget of the tree architecture is  $\log_2(N) \times IL_c$ . Sec. III shows that, by grouping ONUs in some sets, the number of passive elements traversed by optical signals is minimized. Thus, this solution improves WONDER, bus and ring power budgets. The Grouped WONDER (GW), Grouped Bus (GB) and Grouped Ring (GR) architectures are obtained minimizing the power budget functions of the original architectures:

$$\begin{aligned} \min\{PB_{GB}\} &\Rightarrow \frac{\partial}{\partial M} \left( \frac{N}{M} + M \right) = 0 \\ \min\{PB_{GR}\} &\Rightarrow \frac{\partial}{\partial M} \left( 2\frac{N}{M} + 2M - 2 \right) = 0 \\ \min\{PB_{GW}\} &\Rightarrow \frac{\partial}{\partial M} \left( 2\frac{N}{M} + 3 - 2 \right) = 0 \end{aligned}$$

where  $M$  is the number of ONUs in a group. The first two functions have a minimum for  $M = \sqrt{N}$ , while the last one has a minimum for  $M = \sqrt{2N/3}$ . The power budget values for the grouped architectures become:

$$\begin{aligned} PB_{GB} &= 2\sqrt{N} \times IL_c \\ PB_{GR} &= (4\sqrt{N} - 2) \times IL_c \\ PB_{GW} &= (2\sqrt{6N} - 2) \times IL_c \end{aligned}$$

Fig. 11 shows power budget computation for the considered architectures. Dashed lines represent the power budget lower bound in GPON and EPON standard [2], [12] (see also Table III). The tree architecture shows the best behavior, while the WONDER architecture shows the worst one. Grouped

architectures show a better behavior with respect to the original WONDER, bus and ring architectures.

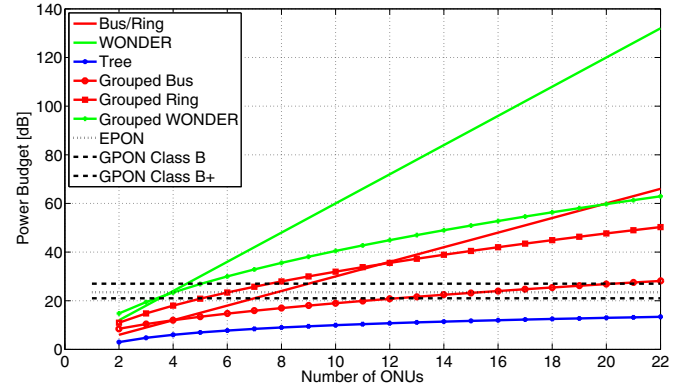

Fig. 11. Power Budget performance

## V. CONCLUSION

In this paper, we show how WONDER can be employed as a PON. WONDER allows communication between ONUs without CO involvement, an important feature for supporting efficiently P2P applications. Besides, it shows interesting fault recovery properties, as it exhibits lower unavailability than all unprotected architectures. The main drawback of the WONDER architecture is represented by its scalability in number of ONUs due to its power budget. However, this limitation can be overcome by grouping nodes in sets, as in the Grouped WONDER (GW) architecture.

## REFERENCES

- [1] *Gigabit-capable Passive Optical Networks (GPON): General characteristics*, ITU-T Std. G.984.1, 2003. [Online]. Available: <http://www.itu.int/rec/T-REC-G.984.1/en>
- [2] *Part 3: Carrier Sense Multiple Access with Collision Detection (CSMA/CD) Access Method and Physical Layer Specifications*, IEEE Std. 802.3ah, 2004. [Online]. Available: <http://ieeexplore.ieee.org/xpl/standards.jsp?start=800&end=899>
- [3] A. Carena, V. D. Feo, J. M. Finochietto, R. Gaudino, F. Neri, C. Pigliione, and P. Poggiolini, "RingO: An experimental WDM optical packet network for metro applications," *IEEE J. Sel. Areas Commun.*, vol. 22, no. 8, pp. 1561–1571, 2004.
- [4] "Wonder - WDM optical network demonstrator over rings." [Online]. Available: <http://www.tlc-networks.polito.it/wonder>
- [5] A. Bianco, J. M. Finochietto, G. Giarratana, F. Neri, and C. Pigliione, "Measurement-Based reconfiguration in optical ring metro networks," *J. Lightw. Technol.*, vol. 23, no. 10, pp. 3156–3166, 2004.
- [6] *Gigabit-capable Passive Optical Networks (G-PON): Transmission convergence layer specification*, ITU-T Std. G.984.3, 2004. [Online]. Available: <http://www.itu.int/rec/T-REC-G.984.3/en>
- [7] A. Bianco, D. Cuda, J. M. Finochietto, F. Neri, and C. Pigliione, "Multi-Fasnet protocol: short-term fairness control in WDM slotted MANs," in *Proc. GLOBECOM '06*, San Francisco, CA, USA, Nov. 2006.
- [8] A. Antonino, A. Bianco, A. Bianco, V. De Feo, J. M. Finochietto, R. Gaudino, and F. Neri, "WONDER: A Resilient WDM Packet Network for Metro Applications," *Elsevier Optical Switching and Networking*, vol. 5, no. 1, pp. 19–28, March 2008.
- [9] G. Kramer, *Ethernet Passive Optical Networks*. McGraw-Hill, 2005.
- [10] J. Chen and L. Wosinska, "Analysis of protection schemes in PON compatible with smooth migration from TDM-PON to hybrid WDM/TDM-PON," *OSA J. Opt. Netw.*, vol. 6, no. 5, pp. 514–526, 2007.
- [11] M. Xie, K.-L. Poh, and Y.-S. Dai, *Computing System Reliability: Models and Analysis*. Springer, 2004.
- [12] *Gigabit-capable Passive Optical Networks (GPON): Physical Media Dependent (PMD) layer specification*, ITU-T Std. G.984.2, 2003. [Online]. Available: <http://www.itu.int/rec/T-REC-G.984.2/en>