

ELECTRICAL IMPACT OF PHOTOVOLTAIC PLANTS IN URBAN DISTRIBUTED NETWORK

Original

ELECTRICAL IMPACT OF PHOTOVOLTAIC PLANTS IN URBAN DISTRIBUTED NETWORK / Canova, Aldo; Giaccone, Luca; Spertino, Filippo; Tartaglia, Michele. - STAMPA. - 1:(2006), pp. 381-385. (VI World Energy System Conference Torino (ITALY) 10-12 July 2006).

Availability:

This version is available at: 11583/1485544 since:

Publisher:

Published

DOI:

Terms of use:

This article is made available under terms and conditions as specified in the corresponding bibliographic description in the repository

Publisher copyright

(Article begins on next page)

Electrical Impact Of Photovoltaic Plant In Distributed Network

Aldo Canova, Luca Giaccone, Filippo Spertino and Michele Tartaglia
 Politecnico di Torino
 Dipartimento di Ingegneria Elettrica
 Corso Duca degli Abruzzi 24, 10129 Torino, Italy
 Email: {aldo.canova, luca.giaccone, filippo.spertino, michele.tartaglia}@polito.it

Abstract—This paper presents the problem of the power penetration of photovoltaic (PV) systems in urban networks. After a qualitative problem description, two different environments for the PV systems have been analyzed: rural and urban networks. Concerning the rural network a single line has been simulated in order to evaluate the relation between the number of PV system installed along the line and the maximum PV power installable. In the second part of the paper the possible problems due to the power penetration have been examined concerning a clustered PV system that will be installed in the city of Torino (Italy) in ambit of an EU project.

I. INTRODUCTION

In the past, most of distribution networks was designed in order to operate in radial configuration with a single source. With this kind of network the power flows from the substation to the loads in every point of the grid. Since the traditional energy sources are limited, the world has started to think seriously to some alternative energy sources (renewable and non renewable). Thus, now we are living the development of the Distributed Generation (DG). In this scenario the network has multiple sources and it is possible to have power flow in reverse direction, from DG units to the substations. In this case it is possible to define the Power Penetration [1] that is the percentage of the DG power referred to the rated power network. The reverse power flow is the main problem that makes the integration of the DG units not easy. The introduction of a PV system grid-connected increases the voltage in its Point of Common Coupling (PCC). The voltage level depends on the network configurations, on the load conditions and it is proportional to the instantaneous produced power of the PV system. The electrical distribution utility has to satisfy some constraints about the power quality provided to its customers (Standard EN 50160 [2]). One of these constraints is on the voltage, therefore if the voltage reaches a too high value, the PV systems could be stopped just when the power generated could be maximum (output restriction [3] [4] of the Power Penetration). In this paper the attention will be focused on the possible problem of voltage rise in two different situation. The first one is the connection of PV systems in a “rural” electrical network. The behaviour of the output restriction will be analyzed with the simulation of a single rural line. The second one is the connection in an urban network of a clustered PV system, i.e. a big concentration of PV systems in a relatively small area. The clustered PV system analyzed

will be developed in a district of the city of Torino (Italy) in the ambit of an EU project named POLYCITY [5].

II. PROBLEM DESCRIPTION

Before starting the discussion about the output restriction, it is important to understand how the photovoltaic system produces the voltage rise in its PCC. With reference to Figure 1 \underline{E}_g and \underline{Z}_g are the parameters of the Thevenin generator of the electrical grid, \underline{Z}_{Load} is the impedance of the load, \underline{E}_{PV} and \underline{I}_{PV} are the parameters of PV system model.

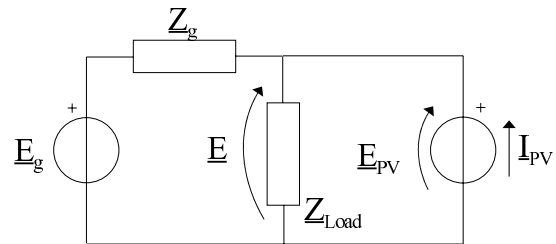

Fig. 1. Electrical systems representation

Using this model the voltage in the PCC can be calculate as shown in (1). The equation shows that the voltage without the PV system ($\underline{I}_{PV} = 0$) is increased of a value proportional to the product $\underline{Z}_g \underline{I}_{PV}$:

$$\underline{E} = \frac{\underline{Z}_{Load}}{\underline{Z}_g + \underline{Z}_{Load}} \cdot (\underline{E}_g + \underline{Z}_g \underline{I}_{PV}) \quad (1)$$

From (1) it is also possible to achieve the limit of the PV current in order to hold the PCC voltage lower than the imposed limit that, for example, can be a portion of the network nominal voltage ($k \cdot \underline{E}_g$). The PV current limit is expressed in (2). Unfortunately, this equation is useful only in order to understand the problem. In fact the values of \underline{Z}_g and \underline{Z}_{Load} are not generally available with good accuracy, therefore it is always necessary a deeper analysis of the problem in different ways. Moreover, in a clustered PV system, the utilization of the equation (2) would be an additional simplification, because the combined work of the PV systems would be neglected.

$$I_{PV} \leq E_g \left[\frac{k}{Z_{Load}} + \frac{k-1}{Z_g} \right] \quad (2)$$

After the overview about the cause of the voltage rise, it is possible to define the *output restriction*: the constraints imposed to the electrical quantities (voltages, currents, frequencies, etc...) must be satisfied in all operational conditions. The output restriction is the limitation of the DG power in order to satisfy these constraints. The maximum admissible power penetration depends on the existing network parameters and, if there are more than one PV system in a “small” area, on the combined operation of all the PV systems. Unfortunately this maximum it is not easy to estimate for the reason explained above.

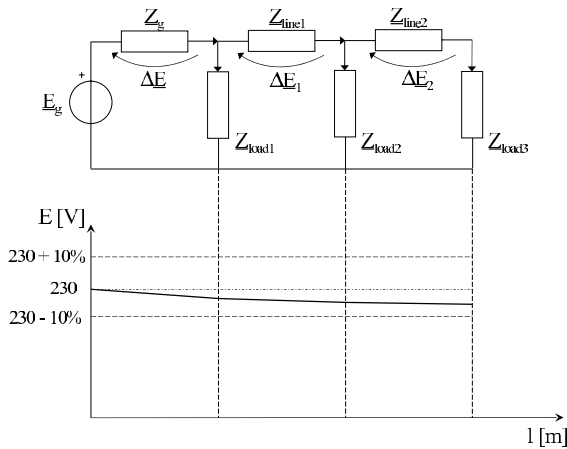

Fig. 2. Voltage profile without DG

The reverse power flow due to the PV systems changes the normal voltage profile over the network length. A qualitative voltage profile without PV system is shown in Figure 2, it is decreasing over the network length and usually the system is designed in order to hold the voltage drop at the end of the line less than 4%.

In Figure 3 a qualitative voltage profile with a PV system inserted at the end of the line is shown. The figure represents an especial situation where the absorption from the loads is low and the PV generation is higher than the total absorption, e.g. at noon of a summer day. In this configuration the voltage is increasing over the network length and the voltage at the end of the line reaches a value higher than 230V. Italian standard CEI 11-20 requires that a DG unit must be managed so that the network can be considered like a “passive network” (in other words, without DG units). This means that if the PV system causes a perturbation in the network, it must be immediately and automatically disconnected from the grid. In order to satisfy what it has just required, Italian standard CEI 11-20 shows typical connection of a PV system that it must be adopted, Figure 4. By the interface device it is possible to think at the network as a passive network because it is equipped

with over-voltage relays and over-under frequency relays (in some cases there is also a device able to measure the variation of the grid impedance, but this last characteristic is not imposed from the Italian standards).

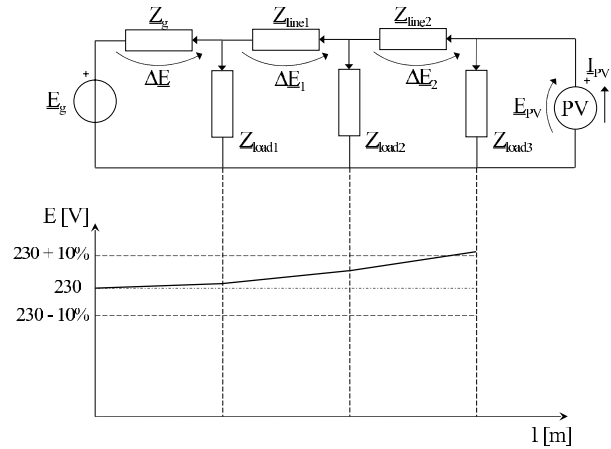

Fig. 3. Voltage profile with DG

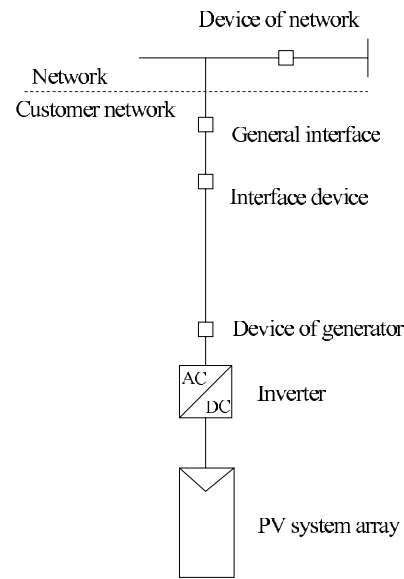

Fig. 4. Typical connection layout of PV system

Now it is possible to understand that if the maximum value of voltage reached in the PCC of the PV system is higher than the setting of the over-voltage relay, the PV system will be disconnected with consequent loss of power. This situation is called output restriction.

There is already an existing study that documents output restriction, it is based on clustered PV systems in Gumna, Japan, [3], [4]. In this case the behaviour of the restriction is different. The interface device, instead of disconnecting the PV systems, forces the Maximum Power Point Tracker (MPPT)

to reduce the output power at the highest acceptable value in order to hold the PCC voltage in the admissible range.

III. UPPER VOLTAGE LIMITS

Firstly, the maximum admissible voltage value has to be evaluated. We have to analyze both interface device specification and standard EN 50160, and then we will take into account the lower limit. Table I summarizes the interface device specifications. As it is clear the interface device allow to the PCC voltage to rise up to 1.2 E_n .

TABLE I
INTERFACE DEVICE SPECIFICATION (CEI 11-20)

Relay	Nominal Values		Intervention value	Accuracy
	Vn/En [V]	f [Hz]		
over-voltage	400/230		1.2 E_n	= 5 %
under-voltage	400/230		0.8 E_n	= 5 %
over-frequency	400/230	50	50.3 or 51 Hz	= 50 mHz
under-frequency	400/230	50	49.7 or 49 Hz	= 50 mHz

The standard EN 50160 instead imposes that, every average RMS voltage value calculated over a period of 10 minutes has to be less than $1.1E_n$. It is worth noting that the two constraints are different because the interface device imposes an upper limit on the instantaneous value of the voltage and the EN 50160 imposes an upper limit on the average value of the voltage. For our simulation we will impose that the instantaneous voltage value must be under $1.1E_n$. This constraint is a sufficient condition for the satisfaction of the interface device specifications and the EN 50160 prescriptions. Finally considering a single-phase system the upper limit will be $1.1 \cdot E_n = 1.1 \cdot 230 = 253V$

IV. PV PENETRATION IN A RURAL NETWORK

In this part of the paper it will be examined the PV penetration in a "rural line", i.e. an electrical line that supplies energy in a zone where there are only a few users and therefore the electrical network capacity is weak. Some simulations will be performed in order to evaluate the relation between the maximum PV power installable and the distribution of this total power along the line. All the simulation will be done in the worst case characterized from zero absorption of the loads. In the simulations the PV system is modeled with a constant power generator working with unitary power factor, in fact the power of the PV systems is imposed from external factor (irradiance, temperature, etc) and the Italian standards impose that a grid-connected PV system has to be regulated with zero reactive power.

We take into account a line of 500 m supplied from a pole MV/LV substation, the characteristics of the supply system are summarized in Table II.

This system is thought to supplying five domestic users. It has the minimal requirements for satisfy the voltage drop limit at the end of the line. The maximum installable power will be evaluated starting from the case in which there is only one PV

TABLE II
SUPPLY SYSTEM CHARACTERISTICS

Transformer		Line (500 m)	
An [kVA]	160	S [mm ²]	25
Pj [W]	2550	r [Ω/km]	0.899
vcc%	4.2	xl [Ω/km]	0.106

system at the end of the line and arriving to the case in which there are ten equal PV systems distributed along the line at the same distances. With reference to Figure 5 the n subscript goes from 1 to 10 and the following equations are valid:

$$E_{PV1}I_{PV1}^* = E_{PV2}I_{PV2}^* = \dots = E_{PVn}I_{PVn}^* \quad (3)$$

$$E_{PVn}I_{PVn}^* = \frac{P_{PVtot}}{n} \quad (4)$$

$$I_{PVn} = \frac{P_{PVn}}{n \cdot E_{PVn}} \quad (5)$$

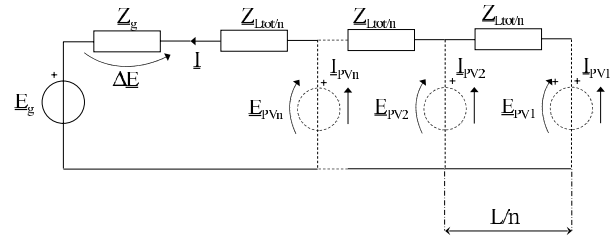

Fig. 5. Simulation network layout

Two different simulation environments have been used, MATLAB and DigSILENT [6]. In the first case the simple equations of the system have been implemented, instead DigSILENT is an simulation software of electrical networks, therefore the components already existing in the software have been used. The maximum installable power is intended as the maximum power installable along the line so that at its end the voltage reaches the limit of 253V. In Figure 6 the main results of the simulations are shown. The y-axis represents the Increment Of total Power (IOP) that can be installed along the line with respect to the maximum PV power installable with one generator at the end of the line. The IOP can be defined as shown below:

$$IOP = \frac{P_{PVtot(n)} - P_{PVtot(n=1)}}{P_{PVtot(n=1)}} \cdot 100 \quad (6)$$

With $P_{PVtot(n)}$ = maximum PV power installable along the line with n PV generator.

The maximum power installable with one PV generator at the end of the line is about 36 kW, instead with ten generators the IOP is about 75%, therefore it is possible to install along the line 63 kW. We can see that the two characteristics are

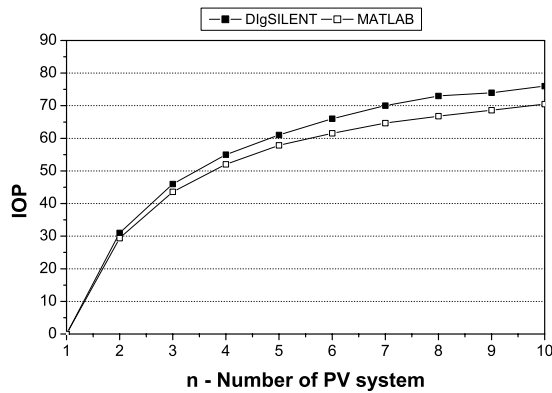

Fig. 6. Simulation results of a rural line

not equal. In fact with DIGSILENT simulator the PV systems have been modeled with a common generator model that does not follow perfectly the equation (3), instead in MATLAB we have imposed the equation (3) for each PV systems.

V. PV PENETRATION IN URBAN NETWORK: ARQUATA DISTRICT WORK EXAMPLE

Arquata is a district of the city of Torino. In this district some innovation concerning the supply side system will be integrated in the ambit of an EU project called POLYCITY. In particular, it will be installed a co-generation plant that will work combined to a district heating network and 150kWp of PV systems will be installed in this configuration:

- 50 kWp installed on a façade of an office building;
- 100 kWp distributed on 11 roofs of the council buildings of the district.

This system is configured as a clustered PV system and, by comparing the characteristics of our project with the characteristics of another already studied clustered PV system in Japan [1], [2], we can see that our district will present a density of installed power of $1.25 \text{ kW}/\text{m}^2$ with respect to the $0.8 \text{ kW}/\text{m}^2$ of the Japanese case. The source of this paper is this higher power density with respect to a clustered PV system that has had PV penetration problems.

A. Electrical network model

In Figure 7 the Arquata electrical network is represented. It is composed by two MV/LV substations characterized by a rated power of 400 kVA and 250 kVA. Seven LV distribution lines start from the substations, four by the first one and three by the second one. Moreover the electrical network is composed by 76 nodes that represent the supply points of the buildings (or sometimes half of building).

The transformer and the distribution lines are modeled with impedances. The values of the transformers impedances have been calculated by mean of their rated values. The line impedances have been calculated using standard cable

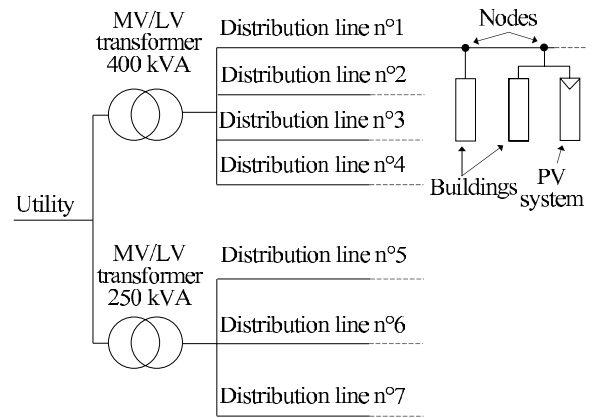

Fig. 7. Arquata electrical network scheme

impedance parameters referred to the cable sections and lengths.

If the electrical network layout is not available it is possible to measure the line impedances with a method that is now under validation with experimental tests. It is possible to see reference [7] for the introduction to the method.

In Figure 7 it is possible to see that the loads (each buildings) and the PV systems are connected to the distribution lines. In the real case each building is supplied by a line that starts from one node and supplies all the common and private uses of the building. However in this paper the minimum aggregation of loads is intended as a building because we assume that the inverters of the PV systems will be installed where the electrical meters are now installed. Therefore the connection of the PV system with the grid will be done in the node of the distribution line, i.e. in parallel with the building.

B. Load and PV system models

For the load model it has been used the "constant current load model", Figure 8.a. The value of the current is derived from the load analysis (see next section). It is worth noting that it is constant only the current magnitude because the phase is imposed by the proper power factor of the load ($\cos\varphi$). Since in our simulation all the loads represent building appliances, we have imposed all the power factors equal to 0.9. The PV system is modeled with a constant power generator working with unitary power factor. With reference to Figure 8.b we have that $\underline{E}_{PVk} \underline{I}_{PVk}^* = \text{cost}$

C. Load analysis

In this section of the paper we will present the results of the analysis of the district loads. Through this analysis it is possible to define the current that have to be used in the load models. The thirty percent of the total loads have been examined and then we have extended the results to the remaining seventy percent.

The starting data are the bills of the whole district for a period of about 10 years. Since these data are affected by

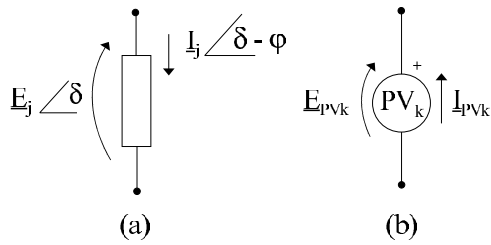

Fig. 8. Load and PV models

TABLE III
LOADS

	Average annual consumption of one private use [kWh/year]	N of private uses	Average annual consumption of one common use [kWh/year]	N of common uses
Building 1	1831	17	1099	2
Building 2	1741	10	648	2
Building 3	1496	15	537	3
Building 4	1387	15	1168	2
Building 5	1658	15	1563	2
Building 6	1606	15	1282	2
Building 7	2130	17	1519	2
Building 8	1723	13	901	2
Building 9	1696	13	1987	2
Building 10	2089	13	1491	2
Building 11	1963	14	760	2

bill's balance, we have chosen a minimal base of the clustering as one year. In Table III the main results of the analysis are shown. It is possible to see the average annual consumption of one private and common uses of the 11 buildings where a PV system will be installed. We can note that the annual consumption is low: the average value for the private uses is about 1750 kWh/year. Starting from this value it is simple to define an average power and the relative average absorbed current that have to be used in the simulation.

Really the simulations have to be done in the most critical case of loads (i.e. minimum load). In our case the minimum load absorption has been imposed as 10% of the average absorption. This value is lower than the value adopted in reference [1], i.e. 25% of the maximum absorption. We have done this choice in order to be sure to take into account the most critical situation of low load.

Moreover in the district is started a monitoring activity on the distribution lines. From the first result, Figure 9, it is possible the monitoring relative to a final part of a distribution line. It represents the absorption of one building. It is possible to see that sometimes the real minimum consumption is lower than 25% of the maximum power. It is also possible to see that our hypothesis is more restrictive than the necessary because the 10% of the average power is always lower than the real minimum absorption, however we have only a little monitored period of the year, therefore in some other period the minimum

absorption could be lower.

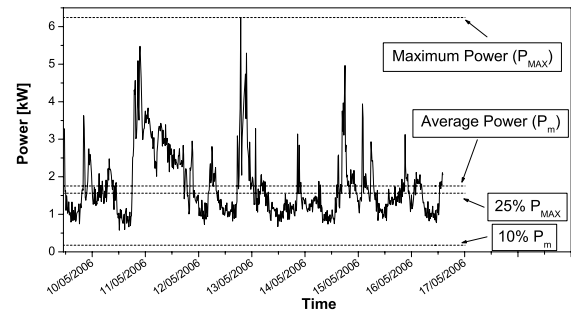

Fig. 9. Monitoring of one distribution line

The work about the monitoring of the distribution network is in progress. Therefore when enough data will be achieved the simulation will be done not only for the worst condition but for all the point of the monitoring. In this way it is possible to obtain results under real conditions of loads.

D. Load flow solution

The solution of the load flow is obtained with the well known "backward/forward sweep" method that is suitable for radial networks.

The convergence of the method is fast: all the simulation have been solved in less than six iterations.

E. Results

Some simulations have been carried out in different conditions of the systems. The *first simulation* is aimed to evaluate the over-voltages along the LV distribution line. The parameters of the simulation are:

- voltage value supplied from the MV/LV substation of 230V;
- maximum generation from the PV system;
- minimum condition of load, i.e. absorbed current equal to 10% of the average absorbed current;

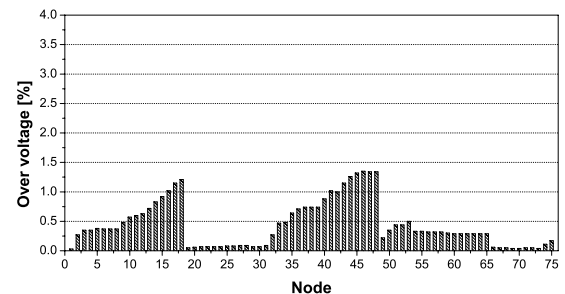

Fig. 10. First simulation, over voltages

With this configuration the maximum over voltage is reached in the node 46, the value is shortly lower than 1.4%. It should be stressed that the chart represents all the seven lines, therefore it does not look like the Figure 3 because it represents only one line.

The *second simulation* is aimed to evaluate the maximum voltage drop along the LV distribution line in normal conditions, i.e with these parameters of the simulation:

- voltage value supplied from the MV/LV substation of 230V;
- zero generation from the PV system;
- average condition of load;

With this simulation we can see that the maximum voltage drop is reached in the node 48, the value a little bit lower than 3%.

The *third simulation* has the same goal of the first one but with different parameters:

- voltage value supplied from the MV/LV substation of 236V, this is the voltage value that allows to vanish the voltage drop in the node 48. This value simulates an intervention on the tap changer of the MV/LV transformer;
- maximum generation from the PV system;
- minimum condition of load, i.e. absorbed current equal to 10% of the average absorbed current.

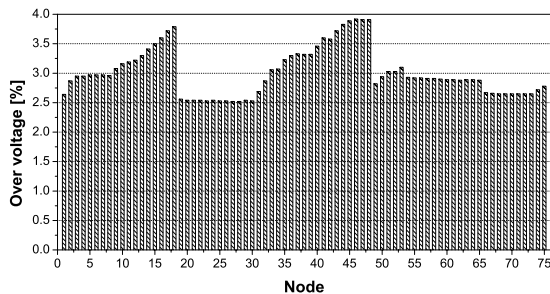

Fig. 11. Third simulation, over voltages

Of course in this way the maximum over voltage is reached in the same node of the simulation one. But the value is near to 4%. With these three simulations we can confirm that the district will not have problem about PV penetration.

We have already evaluated the maximum installable power on the eleven roofs with the *fourth simulation*, i.e. 45 kWp per roof. It is important to note that although this value is acceptable because the total PV power installed is less than the power of the two MV/LV substations and the current generated from the PV system is less than the capacity of the cables, the over voltage on the line exceed the 10%.

VI. CONCLUSION

In this paper the problem of the power penetration of PV system in a rural and urban network have been analysed. It has

been observed that problems can occur mainly in a rural line than in an electrical network of a city because the parameter with more influence on the voltage rise is the distribution line impedance, in fact different methods have been proposed and tested for measuring the grid impedance [7], [8], [9], [10], [11]. In Arquata district most of the cables have high section (95 mm^2) also if they are at the end of the line because in some configuration, i.e. maintenance of one substation, they should transport a consistent share of current. Instead in a rural line the cables sections are low for a lot of meters; therefore in some cases the line impedance has a high value causing a voltage rise that exceeds the limits. Therefore the density of installed PV power (kW/m^2) is not a sufficient parameter in order to define the maximum power penetration because it does not take into account the capacity of the grid.

Finally, it has to be stressed that the problem in the city is not always negligible, in fact when the PV plant size is very high ($\approx \text{MW}$) the voltage rise could be a problems also for the system parallel with an urban electrical network.

VII. ACKNOWLEDGEMENTS

This paper presents some results concerning the European Project POLYCITY (Sixth Framework Programme - Priority 6.1 - Sustainable Energy Systems). Therefore the authors would like to acknowledge the partner of the project who cooperated to this work.

Finally the authors would like to acknowledge Dr. Mauro Monge for the support given with his work.

REFERENCES

- [1] A. F. Povlsen, "Impacts of power penetration from photovoltaic power system in distribution network," report IEA-PVPS Tsk 5, Feb 2002.
- [2] Standard CEI EN 50160 - Voltage characteristics of electricity supplied by public distribution systems, March 2000.
- [3] Y. Ueda, T. Oozeki, K. Kurokawa, T. Itou, K. Kitamura, Y. Miyamoto, M. Yokota, H. Sugihara, and S. Nishikawa, "Analytical results of output restriction due to the voltage increasing of power distribution line in grid-connected clustered pv systems," in *Photovoltaic Specialists Conference, 2005. Conference Record of the Thirty-first IEEE*, 3-7 Jan. 2005, pp. 1631-1634.
- [4] —, "Detailed performance analyses results of grid-connected clustered pv systems in japan - first 200 system results of demonstrative research on clustered pv systems," *20th European PV Solar Energy Conference, Barcelona*, pp. 2466-2469, June 2005.
- [5] POLYCITY official website: www.polycity.net.
- [6] DIGSILENT web site: www.digsilent.de.
- [7] G. Chicco, L. Giacccone, F. Spertino, and G. Graditi, "Experimental methods to evaluate the impact of a photovoltaic system at the point of common coupling low voltage networks," in *Power Electronics, Electrical Drives, Automation and Motion, 2006. SPEEDAM 2006. International Symposium on*, May, 23rd - 26th, 2006, pp. 537-541.
- [8] A. de Oliveira, J. de Oliveira, J. Resende, and M. Miskulin, "Practical approaches for ac system harmonic impedance measurements," *Power Delivery, IEEE Transactions on*, vol. 6, no. 4, pp. 1721-1726, Oct. 1991.
- [9] D. Schulz and H. R., "Islanding detection in germany: current standards and development," *17th European PV Solar Energy Conference, Munich, Germany*, pp. 520-523, Oct 2001.
- [10] W. Xu, E. Ahmed, X. Zhang, and X. Liu, "Measurement of network harmonic impedances: practical implementation issues and their solutions," *Power Delivery, IEEE Transactions on*, vol. 17, no. 1, pp. 210-216, Jan. 2002.
- [11] L. Asiminoaei, R. Teodorescu, F. Blaabjerg, and U. Borup, "A new method of on-line grid impedance estimation for pv inverter," *19th IEEE APEC Applied Power Electronics Conference*, vol. vol 3, pp. 1527-1533, 2004.