

Low-Cost Laser-Based Localization System for Agricultural Machines

*Original*

Low-Cost Laser-Based Localization System for Agricultural Machines / Corbellini, S., Ferraris, F., Parvis, M.. - In: IEEE TRANSACTIONS ON INSTRUMENTATION AND MEASUREMENT. - ISSN 0018-9456. - STAMPA. - 55:5(2006), pp. 1530-1535. [10.1109/TIM.2006.880266]

*Availability:*

This version is available at: 11583/1464584 since:

*Publisher:*

IEEE-INST ELECTRICAL ELECTRONICS ENGINEERS INC, 445 HOES LANE, PISCATAWAY, NJ 08855 USA

*Published*

DOI:10.1109/TIM.2006.880266

*Terms of use:*

This article is made available under terms and conditions as specified in the corresponding bibliographic description in the repository

*Publisher copyright*

(Article begins on next page)

# Low-Cost Laser-Based Localization System for Agricultural Machines

Simone Corbellini, Franco Ferraris, and Marco Parvis, *Senior Member, IEEE*

**Abstract**—This paper describes the design and test of a low-cost localization system for agricultural applications, which determines a tractor position in fields up to 0.5 km with an uncertainty of about 1 m. The proposed system employs a standard unmodified laser head, which is commonly used for field leveling, plus a reference ground-fixed laser receiver and requires neither laser modulation nor expensive time-of-flight measurements of light beams.

**Index Terms**—Contactless position measurement, intelligent systems, laser, signal processing.

## I. INTRODUCTION

RICE cultivation is one of the most water-demanding types of cultivation since, in most cases, the fields are permanently flooded while the rice is growing. A reduction in water wastage can be obtained by reducing the water depth while warranting that no part of the field remain unflooded. This can be obtained by preparing the fields so that they are leveled to within a few millimeters. Specific agricultural tools have been designed to help farmers in this preparation. Most solutions employ a rotating laser to materialize a horizontal plane to be used as the reference in field preparation. A specially designed add-on with a laser receiver, which is mounted on the tractor, reads the laser plane height and drives a blade that is used to move the soil from above-level sites to under-level sites.

This leveling operation could be made rather efficient if it was possible to employ a field altimetric map. By using such a map, one could develop a soil movement strategy that is able to reduce the tractor movement and work. Unfortunately, such altimetric maps are not generally available, and a measurement solution is required to map the fields on demand. One should note that an absolute map is not required, i.e., in terms of real geographical coordinates; for leveling purposes, a local coordinate system is usually enough, which is defined with respect to a specific field point. However, the accuracy in the tractor position should be of the order of 1–2 m to be able to adopt the best soil movement strategy.

## II. ALTIMETRIC FIELD MAPPING

If the farmer is planning to level the field and therefore employs the solution described in the previous section, the altimetric value in terms of distance of the ground from the laser plane is already available so that the map could be easily

obtained if it was possible to continuously know that the tractor is at a horizontal position in the field. The problem therefore becomes how to determine the tractor position with a cheap and robust solution.

Several approaches can be employed to obtain the tractor position; first, the use of global positioning systems (GPSs). Such systems are commercially produced by several companies in the agricultural field and take advantage either of the free wide-area augmentation system (WAAS) technology or of proprietary correction networks to improve localization accuracy. The expected accuracy of these devices is about 3 m (at a confidence level of  $1\sigma$ ; 8 m maximum) for the free WAAS and 1 m (at a confidence of  $1\sigma$ ; 2 m maximum) for the proprietary network. Even though basic GPS receivers have a very low cost, models designed for agricultural applications can be much more expensive, and the subscription to the proprietary correction network, which would be required to reach an acceptable accuracy, can be even more costly.

Similar results can be obtained by employing the positioning service provided by the global system for mobile communications (GSM) framework with the additional problem that GSM service is not available everywhere.

For these reasons, a different approach, which avoids both using the GPS and the GSM, would be preferable. Among the different approaches, solutions based on laser beams could be favorably considered since they have several advantages like substantial immunity with respect to electromagnetic interferences and potentially reduced cost.

The tractor position with respect to a reference point, which is usually located on the field edge, can be conveniently obtained if the tractor distance is measured along with the angle with respect to a reference line, as depicted in Fig. 1. The tractor position is therefore easily obtained as follows:

$$\begin{aligned} X &= D \cdot \cos(\theta) \\ Y &= D \cdot \sin(\theta). \end{aligned} \quad (1)$$

The tractor position can be expressed with respect to the field reference system as

$$\mathbf{r} = D \cdot (\cos(\theta) \cdot \mathbf{i} + \sin(\theta) \cdot \mathbf{j}) \quad (2)$$

where  $\mathbf{i}$  and  $\mathbf{j}$  are the unit vectors identifying the reference system.

If  $\mathbf{r}$  is obtained by independent measurements of  $D$  and  $\theta$ , its uncertainty, which is expressed as distance, can be written as

$$u_{\mathbf{r}} = \sqrt{u_D^2 + D^2 \cdot u_{\theta}^2}. \quad (3)$$

Manuscript received June 15, 2005; revised May 15, 2006.

The authors are with the Dipartimento di Elettronica, Politecnico di Torino, 10129 Torino, Italy (e-mail: simone.corbellini@polito.it; franco.ferraris@polito.it; marco.parvis@polito.it).

Digital Object Identifier 10.1109/TIM.2006.880266

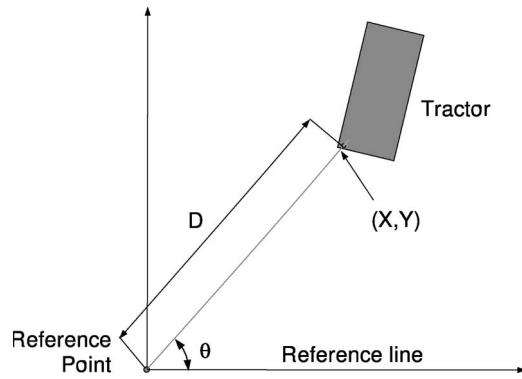

Fig. 1. Polar measurement to obtain the tractor position with respect to a predefined reference point.

### III. DISTANCE MEASUREMENT BY LASERS

Classical distance measurements by laser are obtained by means of three basic approaches, namely 1) time of flight [2] [4]; 2) triangulation [1]; and 3) frequency modulation continuous wave (FMCW) [3].

The first approach is based on the measurement of the required time for a laser beam to reach the object, whose distance has to be measured, and traveling back to the source. A system that implements such a method typically consists of a pulsed laser transmitter, the necessary optics, a receiver channel, and a time-measuring system, which is employed to measure the time between the start and the stop signals generated by the transmitter and the receiver circuitry, respectively. The time of flight has to be measured with high accuracy, and this requires both a narrow optical pulse and a high-resolution time-measuring system. Moreover, to allow the receiver to correctly detect the reflected signal, the transmitted optical peak power could be rather high.

The main advantages of this technique are the ability to obtain results with accuracy on the order of centimeters, or even millimeters, in the range of a few meters to several tens of meters.

The triangulation method is conceptually similar to the vision system that humans use to perceive object distance and works by observing an object from two spatially separated points of view; the laser beam is projected from the source and reflected from the target object toward collection lenses. The lenses, which are typically located adjacent to the laser emitter, focus the spot images on two camera charge-coupled devices (CCDs). The spot positions are then processed to determine the target distance. This technique is employed for measuring distances in the range of a few centimeters to some meters with high accuracy, but it no longer becomes ideal for more distant objects since the accuracy decreases as the angle under which the target is seen by the system gets smaller.

The FMCW approach and its variations are based on the frequency modulation of a laser beam. By means of this technique, the object distance is obtained from phase measurements of both the emitted and the reflected beams. Low-cost systems can be obtained by employing the optical power modulation rather than the classical optical carrier modulation. Such a method is

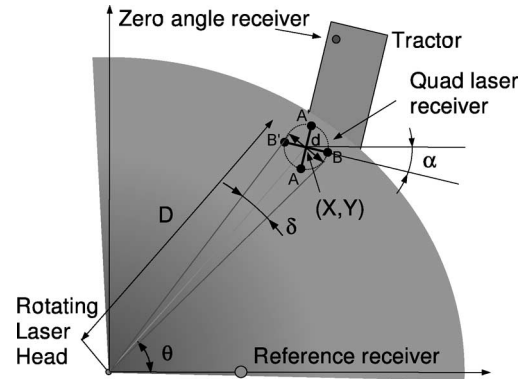

Fig. 2. Implementation of the polar measurement system.

typically capable of dealing with distances of tens of meters and with an uncertainty of a few centimeters.

Unfortunately, all the described techniques, although effective in measuring the distance, would require a tracking system to keep the laser beam pointed to the moving tractor, thus increasing the overall cost. For this reason, the authors have decided to explore a different solution that does not require tracking hardware.

### IV. PROPOSED SOLUTION

The proposed solution takes advantage of the already-present rotating beam and does not require any interventions on the laser head so that it can be employed with almost any commercial head. It employs the scheme shown in Fig. 2 and is composed of the following receivers:

- 1) four laser receivers, which are fixed at the end of a cross-shaped support. This support is mounted on the tractor and is moved by employing the already-present actuator system used for blade movement so that the receivers are kept illuminated by the laser beam;
- 2) a reference laser receiver, which is fixed to the ground and capable of transmitting a radio signal that is received by a receiver on the tractor.

In Fig. 2,  $D$  and  $\theta$  represent the coordinates of the tractor that has to be localized,  $\alpha$  represents the tractor heading angle, and  $\theta$  represents the angle under which the laser receivers are seen from the laser head location.

The basic principle relies on the measurement of the following four time intervals:

- 1) the time between two laser transits on the same point of the tractor  $T$ , which is related to the laser rotation speed (usually between 200 and 2000 r/min);
- 2) the time interval between the laser transit on the reference sensor and on the tractor base sensor  $t_Z$ , which depends on the angle  $\theta$ ;
- 3) the time intervals  $t_{A-A'}$  and  $t_{B-B'}$  between the laser passages on the two sensor couples, referred to as illumination time, which are related to the angle  $\delta$  and to the laser rotation speed.

If the laser revolution speed can be considered constant during a revolution, the four times can be expressed as

$$T = \frac{2\pi}{\omega} \quad (4)$$

$$\begin{aligned} t_Z &= \frac{\delta}{2\pi} T \\ &= \frac{\delta}{\omega} \end{aligned} \quad (5)$$

$$\begin{aligned} t_{A-A'} &\approx \frac{T}{2\pi D} \cdot d \cdot \cos(\theta + \alpha) \\ t_{B-B'} &\approx \frac{T}{2\pi D} \cdot d \cdot \sin(\theta + \alpha) \end{aligned} \quad (6)$$

where  $\omega$  is the laser revolution speed and where the tangent has been substituted with the angle.

By summing the squared values of  $t_{A-A'}$  and  $t_{B-B'}$ , one can obtain a time value that does not depend on the tractor heading angle  $\alpha$ , i.e.,

$$\begin{aligned} t &= \sqrt{t_{A-A'}^2 + t_{B-B'}^2} \\ &= \frac{T}{2\pi D} d \sqrt{\cos^2(\theta + \alpha) + \sin^2(\theta + \alpha)} \\ &= \frac{T}{2\pi D} d \end{aligned} \quad (7)$$

and eventually, the distance is easily obtained as

$$D = \frac{d}{2\pi} \cdot \frac{T}{t}. \quad (8)$$

The angle  $\theta$  is similarly obtained from the time  $t_Z$ , i.e.,

$$\theta = 2\pi \frac{t_Z}{T} \quad (9)$$

and, finally, the tractor position, i.e.,

$$\begin{aligned} X &= D \cdot \cos(\theta) \\ Y &= D \cdot \sin(\theta). \end{aligned} \quad (10)$$

As a bonus, from this method, it is possible to also obtain the tractor heading angle  $\alpha$  as

$$\alpha = \arctan\left(\frac{t_{B-B'}}{t_{A-A'}}\right) - \theta. \quad (11)$$

## V. MEASURING CIRCUIT DESIGN

The overall system uncertainty is expected to be strongly affected by the harsh environment in which the localizer operates mainly due to air turbulence and to the effects of sunlight on the optical sensors. Therefore, the authors have decided to design the system by assigning about 65% of the tolerated uncertainty to the noise-related A-estimated uncertainty components. In addition, since the A-type effects increase with the increasing distance that is to be measured, the system has to be designed to comply with the target uncertainty of 1 m at the maximum

distance, which is expected to be 200–250 m. This choice leads to 0.8 m for the A-estimated components and 0.6 m for the B-estimated components [5], and these have been the values used to design the electronic circuits.

The first design step, starting from (3), is the division of the total allowed uncertainty into two contributes related to  $D$  and  $\theta$ . As an example, by splitting the uncertainty into two equal contributions, it is easy to obtain  $u_\theta = 0.1^\circ$  and  $u_D = 0.4$  m.

The approximations in (6)–(8) also lead to negligible errors in the case of a minimum distance  $D = 5$  m (0.5 cm).

The combined uncertainty of the distance, as expressed by (8), is

$$u_D^2 = D^2 \left[ \frac{u_d^2}{d^2} + \frac{u_T^2}{T^2} + \frac{u_t^2}{t^2} \right]. \quad (12)$$

The most critical terms to be measured are the time interval within the illumination of the two couples of sensors, which can be as low as 10  $\mu$ s at the maximum distance, and the sensor distance, which is subjected to vibrations and harsh environmental conditions. This suggests assigning to these measurements the most important part of the uncertainty while reserving lower values to the other. If all the time intervals are measured starting from the same clock, the uncertainty contribution connected to its actual value can be considered negligible with respect to the other contributions so that the problems remain in the measuring time resolution and in the sensor interdistance measurement.

The revolution time  $T$  is expected to be in the range of 30–300 ms so that if it is measured with a clock with a resolution of 10  $\mu$ s, an uncertainty contribution  $D^2 u_T^2 / T^2$  of less than 0.002 m<sup>2</sup> can be expected, which is negligible with respect to the allowed  $u_D^2$  value of 0.16 m<sup>2</sup>. Therefore, the measurement of  $T$  can be easily obtained with a simple counter clocked at a frequency of 100 kHz. The required counter length, even in the worst case (300 ms revolution time), does not exceed 15 b so that it can be easily arranged.

If the sensor distance is set to  $d = 0.5$  m with an uncertainty  $u_d = 0.5$  mm (the sensor width is of 2 mm), the distance related contribution is 0.04 m<sup>2</sup>, thus leaving uncertainty contribution for the  $t$  measurement of 0.12 m<sup>2</sup>.

At this point, (7) can be used to obtain the required resolution for  $t_{A-A'}$  and  $t_{B-B'}$  in order to guarantee the combined uncertainty bound, which is defined by

$$u_t = \sqrt{\left(\frac{t_{A-A'}}{t}\right)^2 u_{t_{A-A'}}^2 + \left(\frac{t_{B-B'}}{t}\right)^2 u_{t_{B-B'}}^2}. \quad (13)$$

If two identical axes are employed, the combined uncertainty does not depend on the angle of the system orientation  $\alpha$ , and its value is given by

$$u_t^2 = \frac{(t_{A-A'}^2 + t_{B-B'}^2)}{t^2} u_{t_{X-X'}}^2 = u_{t_{X-X'}}^2. \quad (14)$$

The time to be measured at the maximum revolution speed, a distance of 250 m, and a sensor distance of 0.5 m is about 10  $\mu$ s so that a time resolution of about 25 ns is enough to comply with the allowed uncertainty.

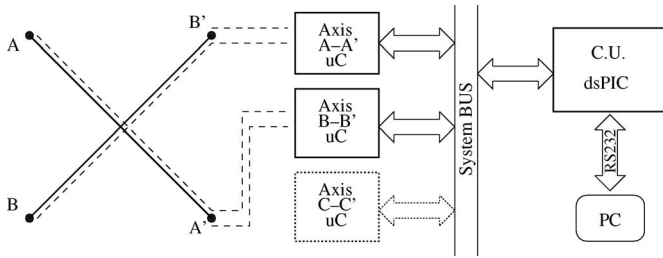

Fig. 3. Prototype block diagram.

This specification involves a high-speed counter that has to be able to work with an oscillator frequency greater than 40 MHz. In addition, when the system is near the head, the absolute value of the interval is very large: In the closest position at 5 m, a 20-b counter is required.

One should note that a critical geometrical configuration for the measurement system occurs when the cross views the laser head under an angle close to  $0^\circ$  or  $90^\circ$ . Under this geometry, one of the two axes is not well illuminated by the laser beam, and the system might not be able to measure the illumination interval on that axis. Anyway, for the distance measurement, this event is not critical, since the missed axis contribution is small in these conditions and can be neglected. However, it must be pointed out that in this situation, the tractor movement direction could be hard to detect.

Eventually, the required uncertainty of  $0.1^\circ$  can be obtained without any problem by employing the same counter architecture already designed for the revolution speed measurement.

## VI. PROTOTYPE ARCHITECTURE

The prototype architecture is shown in Fig. 3, where identical dedicated subsystems are used to measure the time intervals connected to each sensor couple. The subsystems are then interconnected with a management unit, which is used to eventually compute distance and incidence angle.

This way, the subsystems used for time measurement, which have to deal with simple though fast counting operations, can be simplified and optimized, thus reducing their complexity and speeding up the design.

The architecture of each subsystem is shown in Fig. 4 and consists of a simple low-cost microcontroller and a few digital discrete components. The laser beam is detected by means of fast photodiodes whose outputs, after a suitable amplification, drive two flip-flops, which are employed to generate the gate signals for the counting clocks. The revolution measurement clock is obtained directly from the system clock, which is tuned by a crystal oscillator at 20 MHz, whereas the clock for the measurement of the illumination time is obtained by means of a phase-locked loop (PLL) device; as shown by the same diagram, the PLL multiplies the system clock by 4, generating a coherent oscillation at 80 MHz. Since this frequency is too high to be directly applied to the microcontroller inputs, an external fast counter is used to count the least significant four bits. This way, the processor is asked only to manage the overflow signal that has a reduced rate of 5 MHz. Meanwhile, by using an

internal prescaler and an internal counter, the processor is also able to measure the revolution time.

The acquired time intervals are then sent to the management unit, which is used to perform numeric computations and eventually send the final results to a personal computer. Such a unit consists of a 16-b 30-MIPS microcontroller equipped with an hardware multiplier that is useful in this application for the calculation of both (8) and (11).

The connection between the different subsystems is achieved by employing a special bus that implements a serial bidirectional data transfer. Such a bus has the peculiarity of having the data transfer pacing governed by the axis subsystems. This choice allows each subsystem to measure the laser-generated time intervals and contemporaneously transfer the previous measurements to the management unit.

Fig. 3 also shows the possibility to add a third measurement couple, which is referred to as “C–C.” Such an addition can be used if the photodiodes have a reduced angle of sensitivity so that there is the possibility of not being illuminated by the laser. By employing three sensor couples mounted at an angle of  $120^\circ$ , this possibility is greatly reduced at the expense of a rather limited complexity increase. Should the three sensor couples be used, the only change in processing is connected to (7), which changes, depending on the number of illuminated sensors. When all the three axes are illuminated, the equation becomes

$$t = \sqrt{\frac{2}{3} (t_{A-A'}^2 + t_{B-B'}^2 + t_{C-C'}^2)} \quad (15)$$

whereas when only two axes are illuminated, the equation becomes

$$t = \sqrt{\frac{4}{3} (t_{X_1-X'_1}^2 + t_{X_2-X'_2}^2 + (t_{X_1-X'_1} \cdot t_{X_2-X'_2}))} \quad (16)$$

where  $X_1-X'_1$  and  $X_2-X'_2$  identify the axes that detect the laser beam.

## VII. EXPERIMENTAL RESULTS

The prototype was tested in a large car park that reached distances of up to 250 m on well-leveled ground. The employed laser source was a commercial rotary head with a revolution rate of about 500 rpm.

Initially, a series of fixed distance measurements were carried out by employing a single axis of the cross in order to test the related subsystem circuitry. Fig. 5 shows the results obtained at a distance of about 182 m; the dashed line represents the measurements gathered during consecutive revolutions of the laser beam. As expected, despite the low B-component uncertainty, the distance deviation reaches values even ten times bigger than the expected limit; for the measurements of Fig. 5, the standard deviation is about 3.1 m.

In order to explain such results, some investigations were carried out both on the employed head and on the axis circuitry; the head analysis was performed by monitoring the revolution time over a series of consecutive revolutions in order to highlight the speed control effectiveness. The obtained results, which are

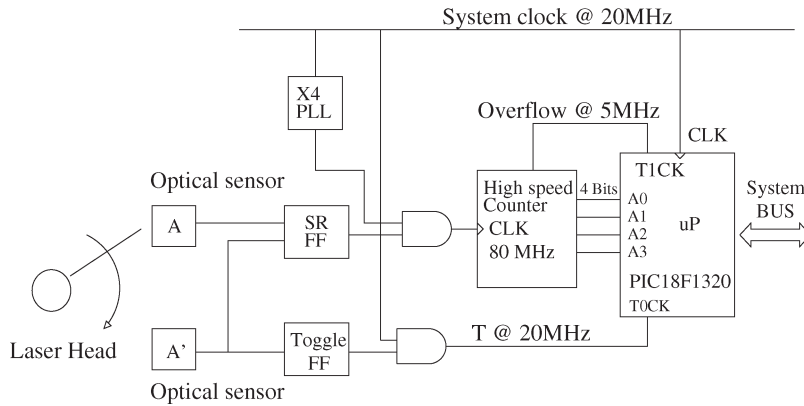

Fig. 4. Axis control architecture.

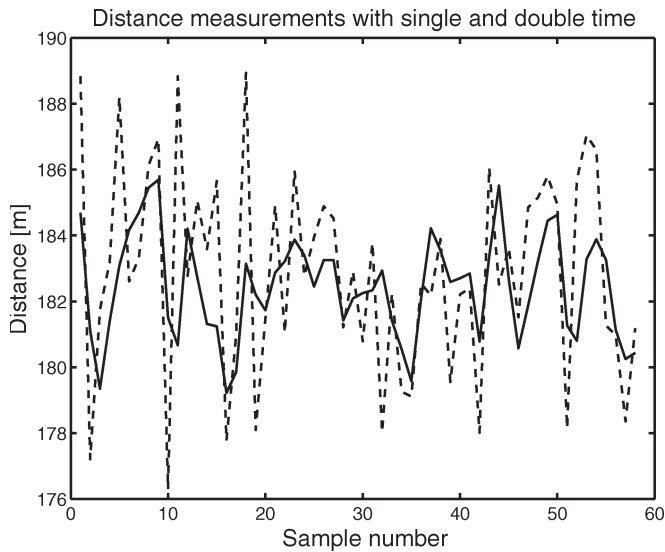

Fig. 5. Example of distance measurements at 182 m obtained during consecutive revolutions of the laser head by employing a couple of sensors. The solid line shows the results obtained by employing the double  $t$  measurement.

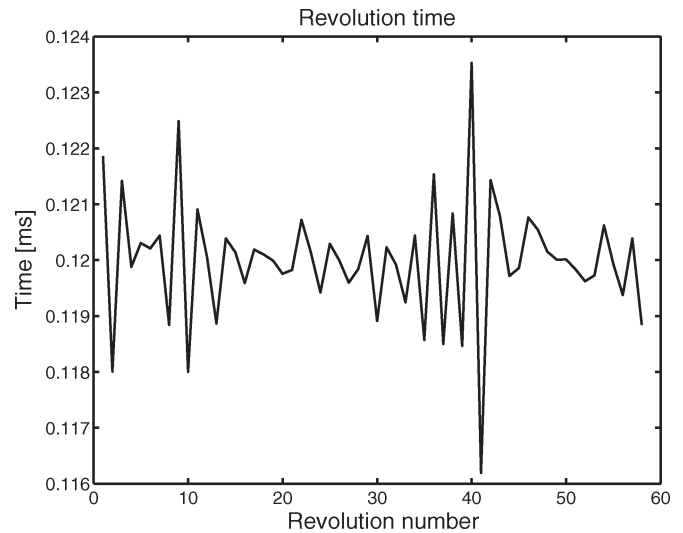

Fig. 6. Example of revolution time measurements that shows the angular speed behavior of the employed laser head.

plotted in Fig. 6, reveal that the rotation speed of the laser head is not well controlled (standard deviation of about 1%); thus, a large jitter affects the measurements. To reduce the jitter effect, it is possible to measure the illumination time both at the beginning and at the end of each revolution and averaging the values. The solid line in Fig. 5 represents the distances that are obtained by using such a procedure: The standard deviation decreases to about 2.3 m.

Meanwhile, the circuit analysis indicated that the amplification of the photodiode signals required an enhancement, particularly when the system was exposed to either direct or diffusive sunlight. To allow the system to work properly under such conditions, the analog amplifiers were therefore redesigned, thus obtaining the final architecture. In this last version, particular attention was also paid to the positions of the components on the circuit board in order to solve some coupling problems between the analog and the digital circuitry.

Eventually, the whole system was tested by performing a series of measurements by employing the two axes' structure at different distances and under several orientations; distance measurements obtained at a distance of about 150 m under

direct sunlight show that despite the unfavorable conditions, the receivers properly detected the laser transit and even the results improved with the standard deviation decreased to about 0.7 m.

Although the accuracy was improved with the last version of the prototype, the results still did not comply with the target uncertainty of 1 m at 200 m. This is also confirmed by the dashed line of Fig. 7, which shows the distance measurements obtained at a greater distance of about 206 m. The standard deviation is about 1.15 m. During 70 consecutive acquisitions, some peaks that are greater than 2 m are quite visible; however, such results represent the raw acquired data; thus, a filtering process can be employed in order to improve the overall accuracy. The actual possibility to employ filtering processes on the raw results depends both on the rotary speed of the employed laser head and on the maximum tractor speed. As an example, in the case of the laser head with about 2000 r/min and a simple eight-sample average, the previous deviation can be reduced down to 20 cm, with small errors due to tractor movement. Instead, for slower heads, such an algorithm would lead to a large error in the position; thus, a different approach has to be employed: Considering that the residual error that affects the measurements is still mainly due to the irregularity

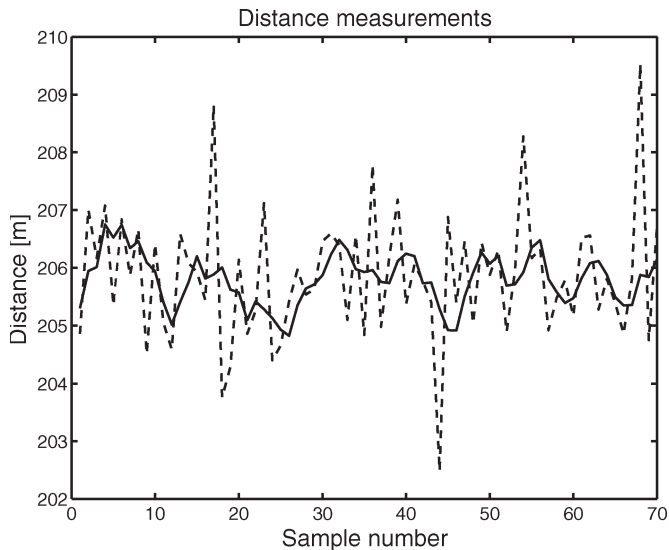

Fig. 7. Example of distance measurements at about 206 m obtained during consecutive revolutions of the laser beam by employing two axes. The dashed line represents the raw results, whereas the solid line represents the filtered results.

TABLE I  
STANDARD DEVIATION FOR DIFFERENT DISTANCES

Distance [m]	25	50	100	150	200	250
Raw dist. dev.	0.10	0.18	0.35	0.70	1.10	1.50
Filt. dist. dev.	0.06	0.10	0.20	0.30	0.45	0.70

of the controlled rotary speed, the results can be improved by employing an algorithm based on a median filter. The solid line of Fig. 7 shows the distance obtained, with a filtering process that involves only three samples in order to preserve the responsiveness for slow heads as well: The standard deviation decreased to about 45 cm.

Table I summarizes the prototype behavior at different distances. As expected, the standard deviation increases with distance, especially for values greater than 100 m; nevertheless, even at the maximum distance of 250 m, the standard deviation remains limited to about 1.5 m. Such a value can be reduced to about 70 cm by employing the filter.

### VIII. CONCLUSION

In this paper, a distance localization system for agricultural applications has been described. The proposed system could assist farmers during the leveling process by providing them an altimetric map that can be used to determine the best soil movement strategy. The discussed solution does not require any sort of modification to the commercial laser heads that are already commonly employed by farmers for soil leveling.

The system is composed of a distance meter and of a reference laser receiver. The first component represents the most critical part; thus, a complete prototype has been designed and tested while the reference receiver is currently being designed.

The experimental results show that the distance can be measured up to about 250 m so that the system can be employed in fields up to 0.5 km if the laser head is placed in the center of the field. At a distance of 250 m, the maximum deviation is

about 1.5 m; however, it decreases to less than 1 m by applying an adequate filtering process.

The overall cost of the realized prototype is about \$200, whereas the cost of the engineered system, which includes the reference receiver, is expected to be less than \$500.

### REFERENCES

- [1] D. S. Pierce, T. S. Ng, and B. R. Morrison, "A novel laser triangulation technique for high precision distance measurement," in *Proc. Ind. Appl. Soc. Annu. Meeting*, Oct. 1992, vol. 2, pp. 1762–1769.
- [2] P. Palojoarvi, K. Maatta, and J. Kostamovaara, "Integrated time-of-flight laser radar," *IEEE Trans. Instrum. Meas.*, vol. 46, no. 4, pp. 996–999, Aug. 1997.
- [3] B. Journet and G. Bazin, "A low-cost laser range finder based on an FMCW-like method," *IEEE Trans. Instrum. Meas.*, vol. 49, no. 4, pp. 840–843, Aug. 2000.
- [4] P. Palojoarvi, K. Maatta, and J. Kostamovaara, "Pulsed time-of-flight laser radar module with millimeter-level accuracy using full custom receiver and TDC ASICs," *IEEE Trans. Instrum. Meas.*, vol. 51, no. 5, pp. 1102–1108, Oct. 2002.
- [5] ENV 13005, "Guide to the Expression of Uncertainty in Measurement," 1999.



**Simone Corbellini** was born in Italy in 1977. He received the M.S. degree in electronic engineering from Politecnico di Torino, Torino, Italy, in 2002, where he is currently working toward the Ph.D. degree in metrology.

His main fields of interest are digital signal processing, distributed measurement systems, and intelligent microcontroller-based instrumentation. He is currently working on the development of a measuring system for physical and chemical characterization of thin films.



**Franco Ferraris** was born in Italy in 1945. He received the degree in electrical engineering from Politecnico di Torino, Torino, Italy, in 1969.

Until 1989, he was an Associate Professor of electronic measurements with the Dipartimento di Automatica e Informatica, Politecnico di Torino. In 1990, he became a Full Professor of electronic measurements at the Dipartimento Elettrico, Elettronico e Sistemistico, University of Catania, Catania, Italy. Since 1991, he has been with the Dipartimento di Elettronica, Politecnico di Torino. His fields of interest

include automatic controls and system theory, biomedical measurements, intelligent measurement systems, and intelligent sensors.



**Marco Parvis** (SM'01) was born in Italy in 1958. He received the M.S. degree in electrical engineering and the Ph.D. degree (Italian Doctorate) in metrology from Politecnico di Torino, Torino, Italy, in 1982 and 1987, respectively.

He is currently a Full Professor of electronic measurements at the Second Faculty of Engineering, Politecnico di Torino. His main fields of interest are intelligent instrumentation, application of signal processing to measurement, and biomedical and chemical measurements. He is currently working on

new sensors for mechanical and chemical quantities and is involved in the development of new distributed measuring systems as well as in the development of a new remotely exercised calibrator for personal-computer-based acquisition boards. He is the author of more than 100 publications.

Prof. Parvis is the Chair of the TC 25 Medical Measurement of the IEEE Society on Instrumentation and Measurement.