

Millimeter wave passive components for polarization measurements

Original

Millimeter wave passive components for polarization measurements / Peverini, O. A.; Baralis, M; Tascone, R; Trincherò, Daniele; Olivieri, A; Carretti, E; Cortiglioni, S.. - In: AIP CONFERENCE PROCEEDINGS. - ISSN 0094-243X. - ELETTRONICO. - 609:(2002), pp. 177-182. (Intervento presentato al convegno Workshop on Astrophysical Polarized Backgrounds tenutosi a Bologna (Italy) nel 9-12 October 2001) [10.1063/1.1471843].

Availability:

This version is available at: 11583/1418606 since:

Publisher:

AIP

Published

DOI:10.1063/1.1471843

Terms of use:

This article is made available under terms and conditions as specified in the corresponding bibliographic description in the repository

Publisher copyright

AIP postprint/Author's Accepted Manuscript e postprint versione editoriale/Version of Record

(Article begins on next page)

Millimeter Wave Passive Components for Polarization Measurements

O. A. Peverini*, M. Baralis*, R. Tascone*, D. Trincherò*, A. Olivieri*, E. Carretti† and S. Cortiglioni†

*IRITI-CNR, Politecnico di Torino, Torino, Italy

†ITESRE-CNR, Bologna, Italy

Abstract. The Stokes parameters of the polarized sky emission are detected by a correlation unit called Hybrid Phase Discriminator (HPD), which uses signals obtained by an Ortho-mode Transducer (OMT). In the millimeter wave range and for rather large bandwidths, heterodyne receivers are not applicable, and the correlation units have to work at the frequency of the radiometer. This contribution deals with a Ka-band prototype of a new configuration of waveguide HPD, which presents a high degree of sensitivity for the detection of linearly polarized radiation.

INTRODUCTION

The construction of multifrequency polarization maps of the galactic emission and the Cosmic Microwave Background investigation require the availability of radiometers with a high level of rejection for the non polarized components [1]. In the Astrophysical experiment SPOrt (Sky Polarization Observatory) onboard the International Space Station (ISS) [2], the instrumentation will consist of four correlation radiometers. In the past, the correlation process was performed after a down conversion by using a local oscillator [3]. Apart from stability problems, this is possible only for narrow band investigations. In the SPOrt project the bandwidths are of 10% centered at 22, 32, 60 and 90 GHz. Obviously, the absolute bandwidths are so large that it is not possible to process the signals at lower frequencies, hence the correlation must be performed at the antenna frequency. The polarized emission will be detected by simultaneously measuring the Q and U Stokes parameters, corresponding to:

$$Q = |E_x|^2 - |E_y|^2 \quad \text{and} \quad U = 2\Re\{E_x E_y^*\} \quad (1)$$

These parameters will be detected by means of correlation units (HPD) whose input signals come from an antenna with double circular polarization [2]. The antenna system consists of a corrugated horn, a polarizer which converts the circular polarizations into the linear ones and an ortho-mode transducer (OMT), which separates the two polarizations. Hence the two outputs of the OMT, under ideal conditions, are:

$$A = \frac{1}{\sqrt{2}} (E_x + jE_y) \quad \text{and} \quad B = \frac{1}{\sqrt{2}} (E_x - jE_y) \quad (2)$$

The correlation product between the two signals A and B yields the Q and U Stokes parameters of the polarized emission:

$$AB^* = \frac{1}{2} (|E_x|^2 - |E_y|^2 + 2j\Re\{E_x E_y^*\}) = \frac{1}{2} (Q + jU) \quad (3)$$

This paper deals with a new configuration of waveguide Hybrid Phase Discriminator which yields at its four output ports the sum and the difference in phase and quadrature of the two input signals. The analog operations are performed at the antenna frequency by means of 3 dB directional couplers and phase shifters. Moreover, two input waveguide filters for the definition of the operative band, and two additional directional couplers for monitoring the total power of the emission are integrated in the HPD. The configuration of this device extends over five levels using E-plane and H-plane discontinuities to form the various components. In this way, a very compact configuration has been obtained which was called FL - HPD (Five Level Hybrid Phase Discriminators, patent pending)

HYBRID PHASE DISCRIMINATORS

The scheme of the correlation units (HPD) used in the radiometers is shown in Fig. 1. The two input signals A and B , attributed to the double circular polarization, are filtered by the two 13 cavity waveguide filters (Fa and Fb), which present a high rejection in the stop band with the purpose of defining the measuring band. Subsequently a fraction of the two signals is drawn off by two 3 dB directional couplers (Hy_a and Hy_b) and is detected by two diodes with quadratic characteristic, to monitor the signal level in the two channels. The remaining fractions (A_0 and B_0) are divided into identical parts along two branches. For this operation, two 3 dB directional couplers (Hy_1 and Hy_2) are used instead of two power splitters because a high level of decoupling between the two branches is required. These are the first components of the correlation block. In the upper branch the signals A_1 and B_1 are combined by the 3 dB coupler Hy_3 to produce the output signals C_3 and C_4 , proportional to $A + jB$ and $A - jB$, respectively. In the lower branch, before the combination performed by the 3 dB coupler Hy_4 , the signal B_2 undergoes a 90° phase shift with respect to the signal A_2 . In this way, the output signals C_1 and C_2 are proportional to $A - B$ and $A + B$, respectively. The detection of the signals C_k , with $k = 1, \dots, 4$, by quadratic characteristic diodes and the subsequent difference by means of two differential amplifiers yields the real and imaginary parts of the average of the correlation product $\langle AB^* \rangle$. The real and imaginary parts of $\langle AB^* \rangle$ correspond to the Q and U Stokes parameters of a linearly polarized radiation, respectively.

$$Q = \frac{1}{2} \langle |A+B|^2 - |A-B|^2 \rangle$$

$$U = \frac{1}{2} \langle |A+jB|^2 - |A-jB|^2 \rangle$$
(4)

In (4) the quantities $|A|^2$ and $|B|^2$ are eliminated by cancellation. Moreover, the level of these two quantities is practically defined by the non polarized component, which can be 40-60 dB higher than the polarized one. Hence, the device must present a very high rejection for the auto-correlation terms. This can be obtained by imposing very severe specification to the various components, even if the admitted error for the detection of the Stokes parameters can be within 10%. The problem was attacked from two sides: first, the development of specialized synthesis and analysis techniques able to guarantee a high level of accuracy in such a way that experimental tuning is not necessary. Second, the study of a compact configuration particularly robust with respect to the mechanical uncertainties.

CONFIGURATION OF THE FL-HPD

The device was designed in rectangular waveguide. The dimensions of the internal waveguides are chosen in order to minimize the dispersion effects of the directional couplers within the corresponding operative bands. By means of appropriate waveguide transitions, integrated in the device, the external connections use standard rectangular

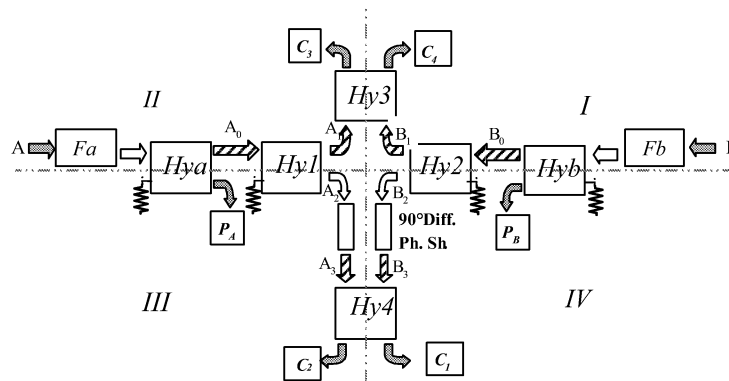

FIGURE 1. Scheme of the HPD where the two input filters and the two directional couplers for monitoring the total power are integrated.

waveguides: WR42 for K-band (22GHz), WR28 for Ka-band (32 GHz), WR15 for Q-band (60 GHz) and WR10 for W-band (90 GHz).

The direct implementation of the circuit scheme of Fig. 1 involves a cross-like geometrical configuration, which requires volume for the K-band realization, and with accuracy problems especially for the higher bands. It is important to define a geometrical configuration whose manufacturing process can be done in a unique phase, by avoiding movements of the sample during the manufacturing. In this way, positioning errors are eliminated. Moreover, within the limits of the mechanical uncertainties, it is important to guarantee a high level of symmetry in order to obtain a high rejection for the non polarized radiation. The selected configuration, called FL-HPD (Five Level Hybrid Phase Discriminator) is a *sandwich* structure, closed by two covers where the input and output standard flanges are placed [6]. The waveguides are obtained within two plates of constant thickness separated by a 0.1 mm thick layer placed in the middle of the device (the thickness of this layer is the same for all the bands). The directional couplers are obtained by coupling two parallel waveguide lengths by means of H-plane rectangular apertures realized on the central layer. The phase shifter consists of a cascade of H-plane stubs obtained by rectangular holes on the adjacent waveguide plate. In order to maintain a high level of integration, the two 13 cavity waveguide filters are obtained by a cascade of E-plane discontinuities. All components form a snake-like geometry which expands over five levels in the E-plane. All the mechanical parts present only through holes, hence they can be manufactured by wire electric discharge machines. Moreover, apart from a 180° rotation, the two waveguide plates are identical and can be manufactured at the same time by overlapping the two pieces. The matched loads of the directional couplers are inside the FL-HPD and are made of ECOSORB MF-190 material. Two kinds of matched transitions are present in the device: L-shaped junctions, to obtain the eight lateral input/output ports in standard waveguide; C-shaped junctions to connect different levels in the waveguide plates. With reference to Fig. 1, the shaded arrows correspond to the L-shaped junctions, whereas the dashed arrows are related to the C-shaped junctions. The white ones represent direct connections. All the devices were designed and analyzed with the methods used in [6].

Q-U COMPENSATION TECHNIQUE AND RESULTS

Based on the previously described architecture, a prototype of the complete HPD in the Ka-band was designed and manufactured. The 8 port-device was characterized by measuring its scattering parameters. In Fig. 2 the reflection and transmission scattering coefficients are reported. In order to evaluate the performance of the FL-HPD the measurements of the scattering parameters were elaborated to obtain the transfer functions which yield the Stokes parameters. If an ideal behavior of the diodes and of the differential amplifiers is assumed, it is possible to define a spectral distribution of the Stokes parameters whose integration yields the relevant data. To this end, one can consider the quantities:

$$C_k = |S_{ka}A + S_{kb}B|^2 \text{ with } k = 1, 2, 3, 4 \quad (5)$$

where, with reference to Fig. 1, S_{ka} and S_{kb} are the scattering parameters of the FL-HPD. By subtracting C_1 from C_2 and C_4 from C_3 , one obtains:

$$\begin{bmatrix} Q_m \\ U_m \end{bmatrix} = \begin{bmatrix} |C_2|^2 - |C_1|^2 \\ |C_3|^2 - |C_4|^2 \end{bmatrix} = \underline{\underline{H}} \begin{bmatrix} \Re\{AB^*\} \\ \Im\{AB^*\} \end{bmatrix} + \underline{\underline{T}} \begin{bmatrix} |A|^2 \\ |B|^2 \end{bmatrix} \quad (6)$$

where

$$\underline{\underline{H}} = \begin{bmatrix} H_{qq} & H_{qu} \\ H_{uq} & H_{uu} \end{bmatrix} \quad \text{and} \quad \underline{\underline{T}} = \begin{bmatrix} T_{qa} & T_{qb} \\ T_{ua} & T_{ub} \end{bmatrix} \quad (7)$$

Moreover, the real elements of matrices $\underline{\underline{H}}$ and $\underline{\underline{T}}$ are defined in terms of the scattering parameters of the device:

$$H_{qq} = 2\Re\{S_{2a}S_{2b}^* - S_{1a}S_{1b}^*\} \quad (8)$$

$$H_{qu} = -2\Im\{S_{2a}S_{2b}^* - S_{1a}S_{1b}^*\} \quad (9)$$

$$H_{uq} = 2\Re\{S_{3a}S_{3b}^* - S_{4a}S_{4b}^*\} \quad (10)$$

$$H_{uu} = -2\Im\{S_{3a}S_{3b}^* - S_{4a}S_{4b}^*\} \quad (11)$$

$$T_{qa} = |S_{2a}|^2 - |S_{1a}|^2 \quad (12)$$

$$T_{qb} = |S_{2b}|^2 - |S_{1b}|^2 \quad (13)$$

$$T_{ua} = |S_{3a}|^2 - |S_{4a}|^2 \quad (14)$$

$$T_{ub} = |S_{3b}|^2 - |S_{4b}|^2 \quad (15)$$

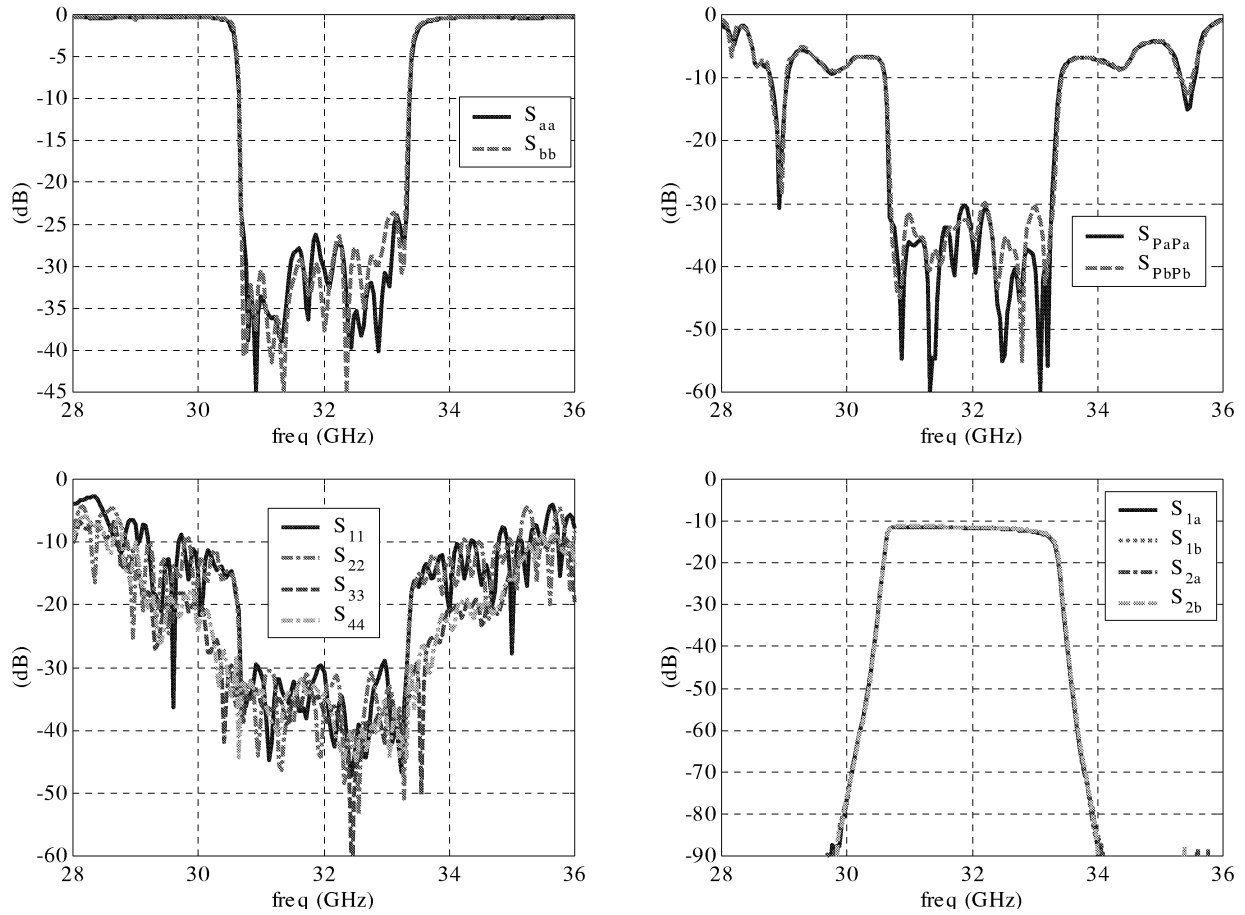

FIGURE 2. Measured reflection and transmission scattering coefficients of the Ka-band FL-HPD.

The eight transfer functions defined by the previous equations are shown in Fig. 3. In the case of a linearly polarized emission, the cross product AB^* can be written as:

$$AB^* = \frac{1}{2} |E|^2 \exp(2j\theta) = \frac{1}{2} (Q + jU) \quad (16)$$

where E is the spectral distribution of the electric field of the emission and θ is the angle with respect to a principal direction of the polarizer. In the Q - U real plane this polarization is described by the vector:

$$\underline{P} = \frac{1}{2} |E|^2 [\cos(2\theta)\hat{q} + \sin(2\theta)\hat{u}] \quad (17)$$

where \hat{q} and \hat{u} are the unit vectors of the Cartesian reference system in the Q - U plane. It describes a circle, when the polarization angle θ ranges from 0 to π . This circle is transformed into a rotated ellipse by the real matrix \underline{H} . As far as the auto correlation terms $|A|^2$ and $|B|^2$ are concerned, they produce a shift of the ellipse in the measured Q - U plane. However, the HPD presents a rejection of the auto correlation terms of about 30 dB, which can be further improved by adopting lock-in techniques. Once the measured Stokes parameters are obtained, equation (6) can be inverted in order to obtain the Stokes parameters of the sky polarized components. To this end, the evaluation of the matrices \underline{H} and \underline{T} and of the auto correlation terms is necessary. This can be accomplished by adopting the online calibration procedure described in [5]. Moreover, one can introduce a ratio between the two conversion factors Q_m/Q and U_m/U , which accounts for the different level of losses between the two channels Q and U . Using a fasorial representation with respect to the variable θ , the vector \underline{P} can be expressed as:

$$\underline{P} = \Re\{\underline{P}e^{j2\theta}\} \quad (18)$$

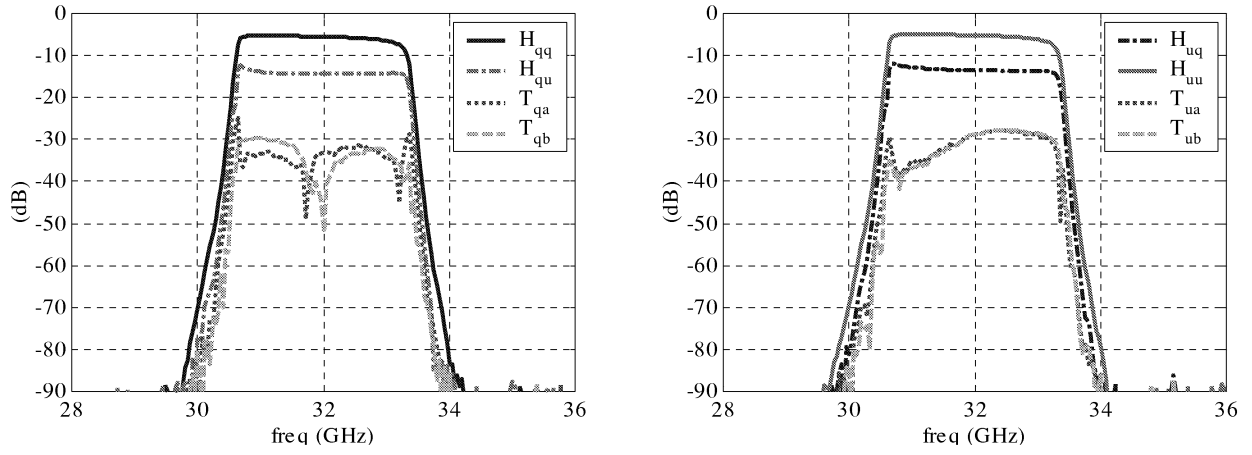

FIGURE 3. Transfer functions corresponding to the evaluation of the Q and U Stokes parameters obtained from the measurements of the Ka-band FL-HPD prototype.

where $\underline{\mathcal{P}}$ is a complex vector

$$\underline{\mathcal{P}} = \frac{1}{2}|E|^2(\hat{q} - j\hat{u}) \quad (19)$$

According to this notation, the measured Stokes parameters are described by the vector $\underline{\mathcal{P}}_m$:

$$\underline{\mathcal{P}}_m = \frac{1}{2}|E|^2[(H_{qq} - jH_{qu})\hat{q} + (H_{uq} - jH_{uu})\hat{u}] \quad (20)$$

which can be written as

$$\underline{\mathcal{P}}_m = \frac{1}{2}|E|^2[\mathcal{H}_q\hat{q} + \mathcal{H}_u\hat{u}] \quad (21)$$

where

$$\mathcal{H}_q = H_{qq} - jH_{qu} \quad \text{and} \quad \mathcal{H}_u = H_{uq} - jH_{uu} \quad (22)$$

are complex quantities. In order to equalize the two channels Q_m and U_m , it is convenient to introduce the two amplification factors D_q and D_u , so that eq. (21) is transformed into:

$$\tilde{\underline{\mathcal{P}}}_m = \frac{1}{2}|E|^2[\mathcal{H}_q D_q \hat{q} + \mathcal{H}_u D_u \hat{u}] \quad (23)$$

Since the amplification factors are applied to the detected D.C. signals, the functions \mathcal{H}_q and \mathcal{H}_u have to be thought as their averages. Projecting $\tilde{\underline{\mathcal{P}}}_m$ onto the orthogonal basis $\underline{\mathcal{P}}$ and $\underline{\mathcal{P}}_\perp = \hat{v} \times \underline{\mathcal{P}}$ (\hat{v} is the unit vector perpendicular to the Q - U plane):

$$p_{\parallel} = \tilde{\underline{\mathcal{P}}}_m \cdot \underline{\mathcal{P}}^* = \frac{1}{4}|E|^4[D_q \mathcal{H}_q + jD_u \mathcal{H}_u] \quad \text{and} \quad p_{\perp} = \tilde{\underline{\mathcal{P}}}_m \cdot \underline{\mathcal{P}}_\perp^* = \frac{1}{4}|E|^4[D_q \mathcal{H}_q - jD_u \mathcal{H}_u] \quad (24)$$

and enforcing $p_{\parallel} = \frac{1}{2}|E|^4$ and $p_{\perp} = 0$ one obtains:

$$D_q = \frac{1}{\mathcal{H}_q} = \frac{1}{|\mathcal{H}_q| e^{j\varphi_q}} \quad \text{and} \quad D_u = \frac{1}{j\mathcal{H}_u} = \frac{1}{j|\mathcal{H}_u| e^{j\varphi_u}} \quad (25)$$

With these two complex amplification factors, the elliptical deformation would be completely recovered. However D_q and D_u must be real, a part from a common phase $\varphi = (\varphi_q + \varphi_u)/2$, which represents the offset of the detection. Hence, enforcing these conditions:

$$D_q = \left| \frac{1}{\mathcal{H}_q} \right| e^{-j\varphi} \quad \text{and} \quad D_u = \left| \frac{1}{\mathcal{H}_u} \right| e^{-j\varphi} \quad (26)$$

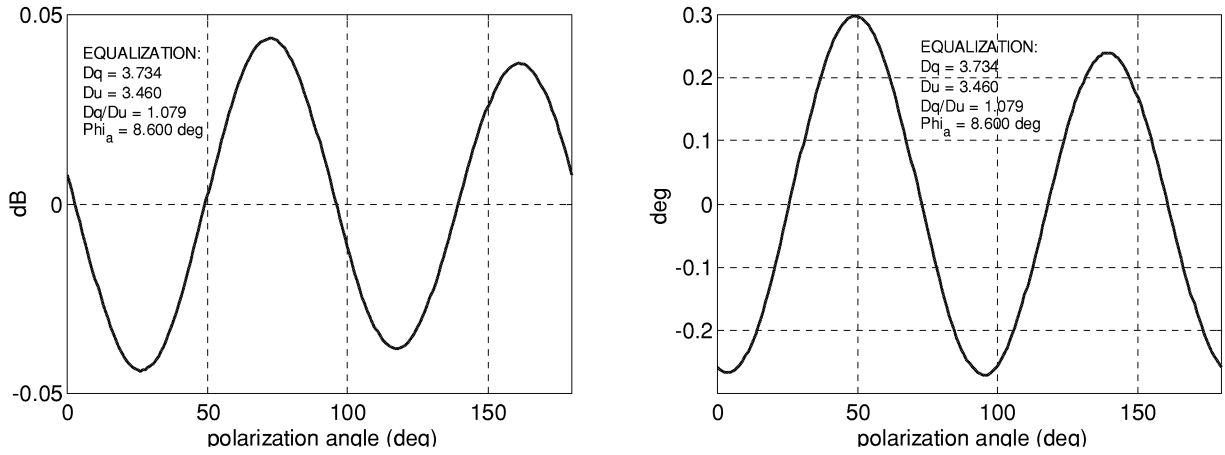

FIGURE 4. Detection error as a function of the polarization angle for a linearly polarized radiation. The angle is detected with an error less the 0.28 degrees. As for the amplitude, the maximum error is 0.04 dB.

the projections (24) become:

$$p_{\parallel} = \frac{1}{4}|E|^4(e^{j\Delta} + e^{-j\Delta}) = \frac{1}{2}|E|^4 \cos(\Delta) \quad \text{and} \quad p_{\perp} = \frac{1}{4}|E|^4(e^{j\Delta} - e^{-j\Delta}) = \frac{j}{2}|E|^4 \sin(\Delta) \quad (27)$$

where $\Delta = (\varphi_q - \varphi_u)/2$. By these projections it is possible to evaluate the axial ratio of the ellipse, which defines the maximum error $(1 + \tan\Delta)/(1 - \tan\Delta)$. Finally, in order to recover the right level of the Q and U Stokes parameters, the factors D_q and D_u are divided by $\cos(\Delta)$. By applying these amplification factors to the measured data of Fig. 3, the detection error of the linearly polarized radiation is reduced from 0.17 dB to a value better than 0.04 dB for the amplitude, whereas for the direction the error of 1.14 deg decreases to 0.28 deg. Fig. 4 shows the amplitude and phase error as a function of the polarization angle when the compensation is applied.

ACKNOWLEDGMENTS

This work has been financially supported by the Agenzia Spaziale Italiana. The authors would like to thank M. Franciotti for the prototype manufacturing.

REFERENCES

1. E.Carretti, R. Tascone, S. Cortiglioni, J. Monari, M.Orsini, *New Astronomy*, Vol. **6/3**, pp. 173-188 (2001).
2. S. Cortiglioni, S. Cecchini, M. Orsini, G. Boella, M. Gervasi, G. Sironi, R. Fabbri, J. Monari, A. Orfei, Ng, Kin-Wang, L. Nicastro, U. Pisani, R. Tascone, L. Popa, I. A. Strukov, " Sky Polarization Observatory (SPOrt): a Project for the International Space Station," *Proc. of ESA Workshop on Space Exploration and Resources Exploitation* , Cagliari, 1998, edited by Mauro Novara-ESTEC.
3. G. Sironi, G. Boella, G. Monelli, L. Brunetti, F. Cavaliere, M. Gervasi, G. Giardino, A. Passerini, *New Astronomy*, Vol. **3**, pp.1-13 (1998).
4. R.Tascone, P.Savi, D. Trincherò, R. Orta, *IEEE Trans. Microwave Theory Tech.*, Vol. **48**, No. 3,pp 423-430 (2000).
5. M. Baralis, O. A. Peverini, R. Tascone, D. Trincherò, V. Niculae, A. Olivieri, E. Carretti, S. Cortiglioni, C. Macculi, C. Sbarra, J. Monari, A. Orfei, G. Sironi, M. Zannoni, "Calibration techniques and devices for correlation radiometers used in polarization measurements," these proceedings.
6. R. Tascone, D. Trincherò, M. Baralis, O. A. Peverini, A. Olivieri, E. Carretti, S. Cortiglioni, "Millimeter wave passive devices for measurements of the polarized sky emission," in the proceedings of *2k1BC Workshop Breuil-Cervinia*, Italy, 2001, edited by M. De Petris and M. Gervasi.