

Design and realization of an on-wafer two port transfer standard

Original

Design and realization of an on-wafer two port transfer standard / Madonna, G.L., Ferrero, A.P., Pisani, U.. - STAMPA. - 2:(1997), pp. 692-696. (27th European Microwave Conference Jerusalem (Israel) 8-12 Sept. 1997) [10.1109/EUMA.1997.337874].

Availability:

This version is available at: 11583/1416372 since:

Publisher:

Published

DOI:10.1109/EUMA.1997.337874

Terms of use:

This article is made available under terms and conditions as specified in the corresponding bibliographic description in the repository

Publisher copyright

(Article begins on next page)

Design and Realization of an On-Wafer Two Port Transfer Standard

GianLuigi Madonna, Andrea Ferrero and Umberto Pisani

Dipartimento di Elettronica
Politecnico di Torino
Corso Duca degli Abruzzi 24
10129 Torino, Italy

Phone: (xx3911) 5644082 Fax: (xx3911) 5644099 E-Mail: ferrero@polito.it

***Abstract** - Among the different techniques for the network analyser calibration, the authors recently introduced the NR procedure based on the concept of transfer standard, characterised by primary laboratories. The paper presents the theory assumed to properly design that standard and some experimental results to verify the accuracy obtained by this calibration.*

1. INTRODUCTION

In a recent work (Madonna et al (1)), the authors presented a network analyser (NWA) calibration procedure called NR (Network Reflect), since it requires the direct and reverse measurement of a two port standard network and the measurement of one standard reflectance. As calibration standards can be used only a single two port passive network (*transfer standard*) and a standard reflectance. The transfer standard (TS) shall be reciprocal but not symmetrical, and must be previously characterised by means of traceable measurement techniques. The network used as standard can be designed on the basis of the customer specifications and on the constraints imposed by the devices to be tested. However, its structure and topology shall be optimised to reach higher accuracy.

In this work the theoretical considerations and an experimental investigation are carried out to properly design that standard device. It is shown that, when the two-port TS is well designed and characterised, the NWA comes out calibrated with high accuracy. The NR calibration technique seems very attractive since it simplifies in several cases the calibration problems.

For example, when two coaxial connectors with the same gender (male-male) are required, the NR avoids the adapter removal procedure since the calibration can be carried out by means of two connections of the same special designed transfer standard.

2. NR CALIBRATION ALGORITHM

According to the linear error model described by Ferrero and Sanpietro (2), the equation that ties the actual DUT scattering matrix S to the measured one S_m is :

$$\mathbf{M} + \mathbf{SLS}_m - \mathbf{SH} - \mathbf{KS}_m = \mathbf{0} \quad (1)$$

\mathbf{M} , \mathbf{L} , \mathbf{H} and \mathbf{K} are 2x2 and diagonal matrices which contain the error coefficients.

The NR calibration algorithm uses the following standard sequence:

- a fully-known two-port non-symmetrical device (the so called transfer standard TS) whose S-matrix is S is first measured in *forward* configuration, obtaining S_m^f ;
- afterwards, the same TS is measured in *reverse* configuration, i.e. swapping port1 and port2, obtaining S_m^r ;
- finally an additional one-port standard is measured to complete the calibration procedure. Let Γ_{m1} be the measured reflection coefficient of this standard Γ_1 at port1.

Obviously, the TS can be reciprocal but not symmetrical, in order to provide different information in forward and reverse case. No constraint applies to one-port reflectance; in particular, it can be obtained as the input impedance of the TS with the second port disconnected. This method obviously requires an additional characterisation of the TS in the open circuit configuration, but it allows to perform an entire calibration process with different measurements of a *single* standard device.

The collection of these nine standard measurements form a linear system, as detailed in Madonna et al (1)

$$\mathbf{N}\mathbf{u} = \mathbf{g} \quad (2)$$

where \mathbf{u} is the vector of the unknown error coefficients, i.e. the matrix elements

$$\mathbf{u} = [M_{11} \ M_{22} \ L_{11} \ L_{22} \ H_{11} \ H_{22} \ K_{22}]^T \quad (3)$$

being K_{11} assumed to be equal to one.

The rank of (2) is equal to seven and its solution can be expressed as

$$\mathbf{u} = \mathbf{N}^+ \mathbf{g} \quad (4)$$

where \mathbf{N}^+ is the pseudo-inverse matrix of \mathbf{N} :

$$\mathbf{N}^+ = (\mathbf{N}^T \mathbf{N})^{-1} \mathbf{N}^T \quad (5)$$

3. CONSIDERATIONS ON THE TRANSFER STANDARD DESIGN

The effectiveness of the NR calibration algorithm strongly depends on the TS parameters. Matrix \mathbf{N} and vector \mathbf{g} contains both the real and the measured scattering parameters of the standard devices. Thus the accuracy of the error coefficients is affected by imperfections in the standards models, as well as by measurement errors due to noise and not perfect repeatability of the connections. The effect of such errors depends, in turn, on \mathbf{N} and \mathbf{g} ; in particular, on the TS scattering parameters.

A general way to approach this problem consists in studying the sensitivity of system (2) to changes of its coefficients. An important parameter is the *condition number* $\kappa_2(\mathbf{N})$ of matrix \mathbf{N} , defined as (Golub and Van Loan (3))

$$\kappa_2(\mathbf{N}) = \|\mathbf{N}\|_2 \left\| (\mathbf{N}^T \mathbf{N})^{-1} \mathbf{N}^T \right\|_2 \quad (6)$$

where $\|\mathbf{N}\|_2$ is the matrix 2-norm of \mathbf{N} .

Number $\kappa_2(\mathbf{N})$ depends on the standards parameters, but also on their measurements. This means that, for a given TS, the condition of the problem depends on the error coefficients themselves, thus, at the end, on the NWA used. Since the aim of this analysis is to obtain general guidelines for the TS design, the problem is investigated under *quasi-ideal NWA* conditions. In particular, if a well-balanced test-set is used, it is not meaningless to assume, during the computation of $\kappa_2(\mathbf{N})$, that:

$$M_{11} = M_{22} \approx 0 \quad L_{11} = L_{22} \approx 0 \quad (7)$$

$$H_{11} = H_{22} \approx -1 \quad K_{22} \approx 1 \quad (8)$$

which obviously means $\mathbf{S}_m \approx \mathbf{S}$.

Though several TS topologies were investigated, a simple circuit was considered in this analysis in order to reduce the computational effort. Its schematic is shown in figure 1; the values of the two resistors R_S and R_P are the parameters that can be tuned to optimise the performance of the calibration process. Figure 2 shows the condition of system (2) under quasi-ideal NWA assumptions, for different values of R_S and R_P .

To further improve the choice of the proper resistor values, the error propagation from the standard parameter to the error coefficients was also studied. The relationship $\delta \mathbf{u} = f(\delta s)$, where δs represents the errors on the different standard parameters was computed. As example, figure 3 shows the influence of an incorrect model of the one-port reflection standard on the error term L_{11} versus the various possible values of R_s and R_p . These results show that a proper choice of R_s and R_p minimises the influence of such imperfect standard as also proven by experimental results.

4. REALIZATION OF THE TRANSFER STANDARDS AND EXPERIMENTAL INVESTIGATIONS

Figure 4 shows the layout of the set of TS devices designed with different topologies and parameters. The standard devices are coplanar (CPW) passive networks which are realised on a 100 μm -thick sapphire substrate in thin-film technology and measured with 150 μm -pitch probes up to 26 GHz. Note on the bottom of the layout the traditional standard and verification devices for LRM calibration.

A subset of the TS devices is designed with the topology shown in figure 1 according to the ideas described in the previous paragraph. Figure 2 shows that their parameters are chosen to optimise the condition of the calibration system.

The performance of each TS is tested as follows. First of all, the NWA is calibrated with a traditional LRM procedure (Eul and Schieck (4)), using a 1.5 ps line and two dc-measured loads. The so calibrated NWA is assumed as the reference instrument. Afterwards, each TS is tested following three distinct steps.

1. The TS device is characterised using the LRM calibrated NWA.
2. An NR calibration is performed using the same TS and an ideal short (the same used in LRM calibration as reflect) connected at port 1.
3. Finally, some verification devices are measured and corrected with both the LRM and NR method.

Figure 5 shows the scattering parameters of a 3ps verification CPW line, obtained by the LRM and two NR calibrations performed with different TS devices. The first calibration (NR case a) uses the set of R_s and R_p which theoretically minimise the error propagation and the condition number and it has a dramatically better performance than the second one (NR case b) whose R_p and R_s value were outside of the best conditions.

5. CONCLUSION

A theoretical and experimental investigation of the impact of proper standard design on the recently proposed NR calibration technique was given. This work proves that when the two port transfer standard is well designed and characterised the resulting NWA calibration gives high accuracy and makes this new calibration technique feasible and attractive.

6. ACKNOWLEDGEMENT

The authors would like to thank Kevin Kerwin and Rob Chavez of HP Microwave Technology Division for the concrete support and the suggestions in the thin film substrate design and realisation.

REFERENCES

- (1) G.L.Madonna, A.Ferrero and U.Pisani, "A Simple NWA Calibration Algorithm Based on a Transfer Standard", 1997, *Proc. IEEE Instr. and Meas. Tech. Conf. IMTC'97*, Ottawa, May 19-21.
- (2) A.Ferrero and F.Sanpietro, "A Simplified Algorithm for Leaky Network Analyzer", 1995, *IEEE Microwave Guided Wave Lett.*, vol.5, pp.199-121.
- (3) G.Golub and C.Van Loan, *Matrix Computations*, 2nd ed., 1989, Baltimore, John Hopkins University Press.
- (4) H.Eul, B.Schieck, "Thru-Match-Reflect: one result of a rigorous theory for de-embedding and network analyzer calibration", 1988, *Proc. 18th Euro. Microwave Conf.*, pp. 909-914, Sep.1998.

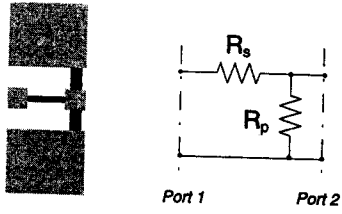

Fig. 1. Layout and schematic of the TS used for optimization.

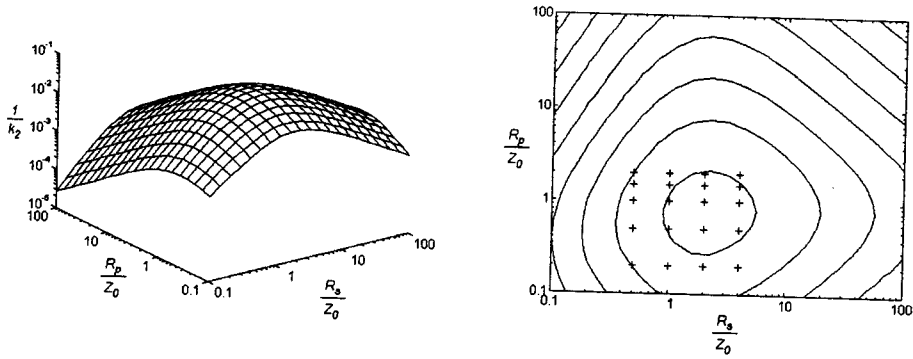

Fig. 2. Condition of the calibration system versus different values of the TS resistors. The + symbols represent the devices that were realized on the thin-film substrate

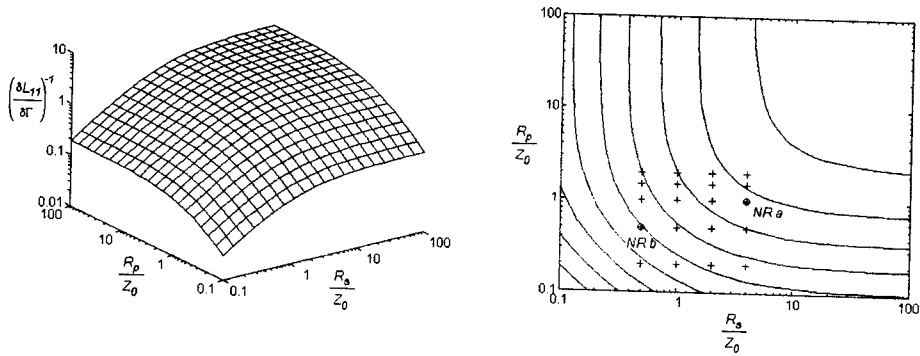

Fig. 3. Error propagation from the standard parameter Γ_1 to the error coefficient L_{11} as a function of the TS parameters. The + symbols represent the devices that were realized on the thin-film substrate, while the circles refers to the TS devices that have been used in the NR calibrations of figure 5.

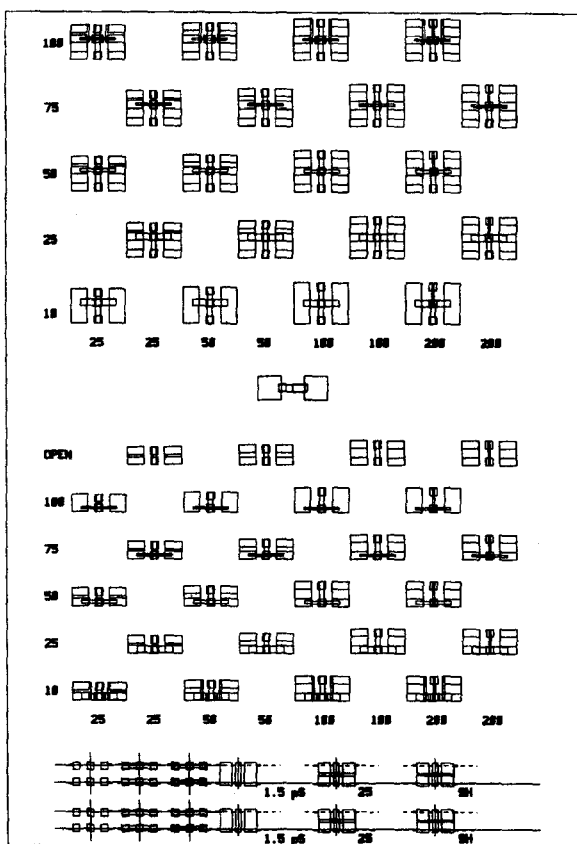

Fig.4. Layout of the entire set of thin film TS devices.

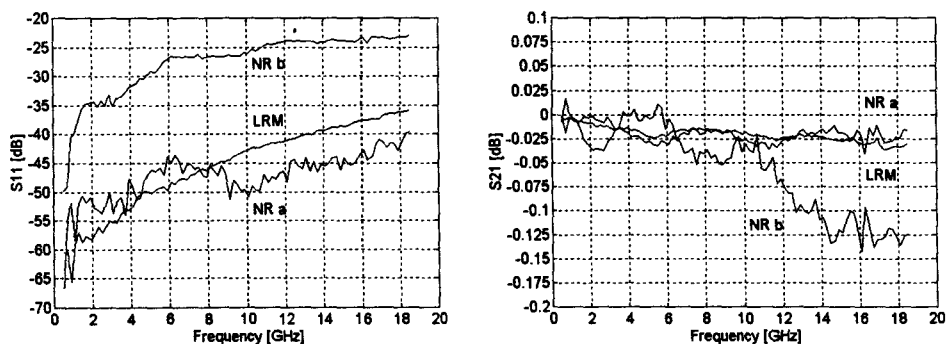

Fig.5. Measurements of a 3 ps verification CPW line with three different calibrations: an LRM reference calibration and two NR calibrations performed with different TS devices (case a: $R_s=200\Omega$, $R_p=50\Omega$; case b: $R_s=25\Omega$, $R_p=25\Omega$).