

On the Modeling of Packages from their Time Responses

Original

On the Modeling of Packages from their Time Responses / Canavero, Flavio; GRIVET TALOCIA, Stefano; Kruger, H.; Maio, Ivano Adolfo; Stievano, IGOR SIMONE; Thoma, P.. - STAMPA. - (2002), pp. 69-72. (Intervento presentato al convegno 6th IEEE Workshop on Signal Propagation on Interconnects (SPI2002) tenutosi a Castelvecchio Pascoli (Italy) nel May 12-15) [10.1109/SPI.2002.258285].

Availability:

This version is available at: 11583/1409382 since: 2015-07-14T12:10:11Z

Publisher:

IEEE

Published

DOI:10.1109/SPI.2002.258285

Terms of use:

This article is made available under terms and conditions as specified in the corresponding bibliographic description in the repository

Publisher copyright

(Article begins on next page)

On the Modeling of Packages from Their Time Responses

F. G. Canavero¹, S. Grivet-Talocia¹, H. Krüger², I. A. Maio¹, I. S. Stievano¹, P. Thoma²
¹ Politecnico di Torino, Italy ² CST, Darmstadt, Germany

Abstract

We address the modeling of packages by the estimation of their poles from time responses. Such an approach is suitable for structures with many terminals and can produce low-order very accurate models. A real-world modeling example is used for illustration.

Introduction

Nowadays, macromodels describing the components of modern interconnection systems and enabling their simulation by means of standard circuit simulators are attracting growing interest. The macromodeling approach, in fact, offers both high efficiency and accuracy. It splits the simulation problem into two separate stages: higher order effects taking place inside components are handled during the development of macromodels; the system behavior is then obtained by simulating an electrical network of reduced complexity that reproduces the behavior of the original components.

In this paper, we deal with the development of macromodels for linear packages from their measured or simulated (*e.g.*, via a fullwave solver) responses. From a formal point of view, this problem amounts to seeking equivalent circuits for nearly *electrically short* linear junctions from samples of their port responses. Recently, a great deal of research has been devoted to this problem (*e.g.*, see [1, 2, 3, 4, 5, 6]), exploiting several methods and different types of input data, *e.g.*, time samples of port voltages, currents or wave variables and frequency samples of matrix network functions. All methods work by fitting rational models to the device responses, yet some of them emphasize the role of model poles by trying the estimation of the actual device poles that are in the modeling bandwidth [1, 6].

The aim of this paper is to report on our recent experience in the macromodeling of packages from transient scattering data via the estimation of device poles. The estimation of the device poles yields to models having a strong physical relation to the original device. Ideally they are defined by the device poles within the modeling bandwidth and are free from spurious dynamic behavior that could affect overfitted models. Besides, scattering data are the natural choice for the characterization of wideband linear junctions and to avoid their conversion to other input data types is a safe practice. A possible disadvantage is that the estimation of device poles from scattering data can be difficult, because frequency-domain scattering functions are usually smooth well behaved functions. However, such functions are also easier to fit and, when the accuracy of estimated poles is sufficient, they lead to very accurate models.

Problem and modeling steps

The device to be modeled is a generic linear junction with m accessible ports, as the one shown in Fig. 1. The device is of distributed nature, therefore an infinite number of poles would be required for an accurate representation of the input/output relations $Y(s) = S(s)U(s)$, where U and Y are vectors collecting all port wave variables, and $S(s)$ is the device scattering

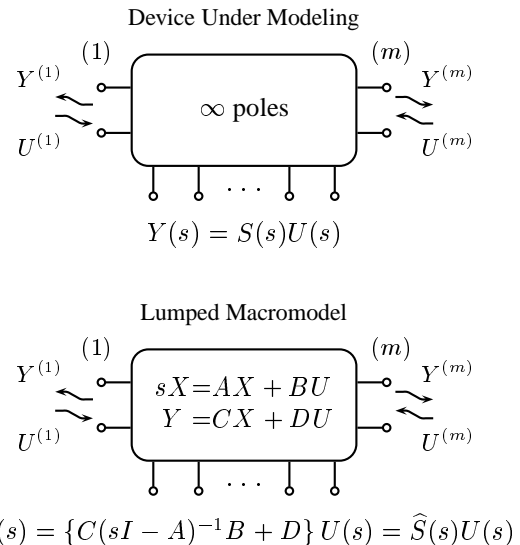

Figure 1: State-space based macromodeling. Arrays Y and U collect input and output wave variables at all ports.

matrix. The goal is to identify a linear m -port lumped system (defined by the matrices $\{A, B, C, D\}$ of a state-space realization and having n poles), such that all entries of scattering matrix $\hat{S}(j\omega)$ approximate the true ones over a specified *modeling bandwidth* $|\omega| < \Omega$. The input data for the estimation of the model parameters $\{A, B, C, D\}$ are the samples u_k and y_k of a suitable set of transient input and output waveforms, where k denotes the time index with a suitable sampling time T_s . Such waveforms can be obtained, *e.g.*, from a full-wave transient simulation based on spatial discretization of electromagnetic fields (as in this paper) or from experimental measurements.

Modeling approaches based on the estimation of the device poles solve this problem by carrying out the following conceptual steps: (a) *pole estimation*; (b) *residue estimation*; (c) *passivity testing and enforcement*; (d) *A, B, C, D estimation*; (e) *circuit synthesis*. In actual implementations, steps (a), (b), (c) and (d) above may be ordered and grouped differently, but we keep them separate for illustrative purposes. Steps (a) and (c) are the crucial ones, because the success of the modeling process completely relies on the ability to detect and accurately estimate the device poles, whereas the enforcement of passivity is mandatory and not trivial. In this paper we concentrate on these two crucial steps by illustrating the performances of an estimation approach from the *system theory* area and by shortly addressing the testing and enforcement of passivity.

Pole estimation

In order to discuss estimation performances, it is useful to start by remarking that no pole estimation method can guarantee success for every possible modeled system. As an example, nearly matched transmission lines and Butterworth's filters are stiff cases where any pole estimation attempt is likely to fail. For these cases a modeling approach without emphasis on

the system poles can be more effective. Universal applicability, therefore, is not a reasonable specification for a pole estimation algorithm. Instead, the usefulness of an estimation approach should be assessed by its ability to handle cases of practical interest for a reasonable amount of input data and computational efforts.

In our modeling experiments, we obtained good estimation results with the Block Complex Frequency Hopping (BCFH) algorithm of [1]. Such an approach relies on the convergence property of Padé approximants, that guarantee the estimation of the actual poles of the modeled system. Unfortunately, in our application, the evaluation of scattering matrix moments required by the BCFH algorithm from time-domain samples is affected by truncation error. We were unable to sufficiently reduce this error, that limited the sensitivity and accuracy of the estimation via Padé convergence.

Useful alternative techniques for the estimation of poles can be found in the system theory area under the collective name of *Subspace State-Space System Identification* (4SID) methods [8]. The 4SID methods determine a discrete-time state-space realization of the modeled system via direct identification of the realization matrices. The poles distribution is a byproduct of this one-step procedure, since such state-space representation can be directly used to synthesize equivalent circuits. These methods have interesting properties and are still scarcely exploited for the modeling of circuit elements (the *Pencil of Function* is the only method of this class widely applied to circuit modeling). Some of these methods are named *direct*, as they work directly on the sequences of input and output samples, without need to compute the system matrix impulse response or network function. Direct methods are designed for persistent input signals and can incorporate measures to limit the effect of noise [8]. This means that, in our modeling problem, they can estimate poles directly from the raw samples of the input and output transient waveform, with a reduced sensitivity to their truncation.

In order to illustrate the direct method exploited in this study [8], we focus on a discrete-time state-space single-input/single-output system (*i.e.*, a one port circuit element, the generalization to multiport elements being immediate)

$$\begin{cases} x_{k+1} &= \tilde{A}x_k + \tilde{B}u_k \\ y_k &= \tilde{C}x_k + \tilde{D}u_k \end{cases} \quad (1)$$

where x denotes the set of internal discrete-time states.

First, we note that the above system may be rewritten in matrix form as

$$\mathcal{Y} = \Gamma \mathcal{X} + \Phi \mathcal{U}, \quad (2)$$

where $\mathcal{U}, \mathcal{Y}, \mathcal{X}$ denote block Hankel matrices of input, output, and state time sequences, respectively. We recall that, given some sequence z_k , the corresponding Hankel matrix is defined as $(\mathcal{Z})_{ij} = z_{i+j-1}$. In the above expression Γ represents the observability matrix

$$\Gamma = \begin{bmatrix} \tilde{C} \\ \tilde{C}\tilde{A} \\ \tilde{C}\tilde{A}^2 \\ \vdots \end{bmatrix}, \quad (3)$$

while Φ is a Toeplitz matrix of impulse responses. A remarkable feature of Eq. 2 is that the output matrix is expressed as a linear combination of state matrix and input matrix. Therefore, a suitable projection of \mathcal{Y} onto some linear space orthogonal to \mathcal{U} leads to an estimate of the observability matrix, which in turn can be used to estimate the state matrix \tilde{A} . One of the most convenient ways to perform the projection is through an *RQ* factorization of matrices \mathcal{Y} and \mathcal{U} , whereas the observability matrix can be computed by a singular value decomposition of the obtained projection [7]. The number of significant singular values in this decomposition gives an estimate of the effective rank of the observability matrix, and consequently of the order n of the state-space system to be identified. From the observability matrix both matrices \tilde{C} and \tilde{A} are readily found by using (3).

Once \tilde{A} and \tilde{C} are known, several approaches [7] can be used to estimate the remaining matrices \tilde{B} and \tilde{D} and convert the macromodel to continuous-time. For multiport circuit elements, all input and output sequences at the ports can be collectively used in a block matrix form to obtain the model realization in a single step. Of course, owing to the size of the involved matrices, this approach can be applied only to circuit elements with a limited number of ports and dynamic order (*e.g.*, up to some ten ports). Since we want to model packages with a large number of ports, we use the 4SID method to obtain only the \tilde{A} matrices of subsets of device ports, taking their eigenvalues as estimates of the poles of the corresponding scattering matrix entries. We assume that the modeled packages have weakly coupled conductors and, consequently, scattering matrices with band structure, *i.e.*, a few non negligible entries in every column. We then use a column-oriented pole search strategy. The ports of the package are excited one at a time and the corresponding outgoing waves are collectively processed to estimate the poles of all (significant) entries of a scattering matrix column. The complete pole set of the package is obtained by comparing and clustering poles estimated from different columns. Once the pole set is built, a partial fraction expansion is considered for every scattering matrix entry and its residues are computed by frequency domain fitting (step (b) of the modeling process). The frequency domain samples needed for the fitting are obtained by transforming the time-domain scattering responses via FFT. As a nearly equivalent alternative, the residues are obtained by directly fitting exponential time-domain responses to the time samples of the input estimation data. Finally we obtain the model realization matrices B, C, D (step (d) of the modeling process) by computing a Gilbert's representation from the residue matrices, as proposed in [9].

The ability of the 4SID method to estimate the poles of sets of scattering matrix entries has been extensively tested for several ideal multiport elements composed of lumped parts and ideal transmission lines and having known pole sets. The tests have been performed by using time sequences of different durations and the same Gaussian input signals needed by transient full-wave solvers. In most of such tests, we found distributions of singular values with evident thresholds. In these cases, the number of significant singular values, *i.e.*, the number of poles or model order, coincided with the number of poles of the modeled functions within the bandwidth of the input signal. More properly, the region of the complex plane where poles can be detected is the halfcircle $\mathcal{C} = \{\Re s < 0\} \cap \{|s| \leq \Omega_i\}$, where Ω_i

is the bandwidth of the input signal. Besides, when this condition occurs, the estimated poles were indeed good approximations of the actual poles within \mathcal{C} . So, even if no mathematical proof of the convergence of estimated poles is known, the 4SID method indeed seems suitable to estimate the poles of network functions in the bandwidth of the input signal used to generate the estimation data. This nice capability holds in spite of the use of vanishing input signals and for time sequences as short as four times the width of the input pulse.

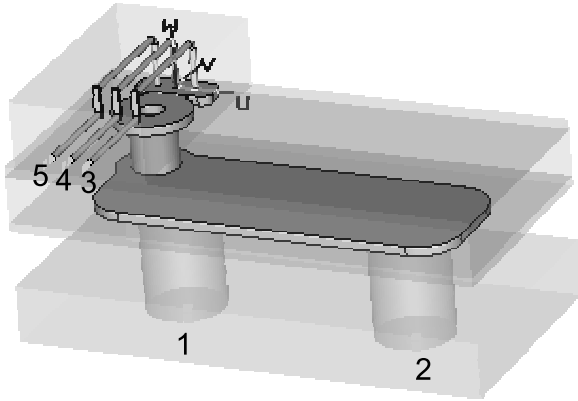

Figure 2: Five-port element used to test pole estimation via 4SID for real modeling problems. The hot terminals of the ports are indicated by the numeric labels.

Estimation data obtained from actual transient fullwave simulations, of course, are affected by numerical errors, that decrease the sensitivity and accuracy of the estimation process. The performance, however, looks sufficient for practical applications. In order to demonstrate the practicability of the approach in real cases, we apply it to the 5-port linear junction of Fig. 2. Such a structure is a component of a real BGA Integrated Circuit package, and its ports no. 1 and 2 are solder points of the package. The structure can be enclosed in a $2.5 \times 1.25 \times 1.25 \text{ mm}^3$ box, all its ports are strongly coupled and its behavior is completely lossless in the modeling bandwidth (see next section).

The scattering responses of the example structure are computed for time domain simulation by the CST's electromagnetic analysis tool [10]. According to the columnwise pole search strategy outlined above, the ports of the structure are excited one at a time by a single Gaussian pulse and, for each excitation experiment, the outgoing waves are collectively processed by 4SID. The most significant difference between realistic cases (like, *e.g.*, this one) and examples defined by ideal multiport elements is that the obtained singular value distributions do not allow a certain prediction of the number of poles that can be estimated. However, the distribution of singular values still allows to estimate the most likely poles set, by comparison of the performances of different models constructed from a different number of poles. In fact, when the number of poles of a model exceeds the number of actual poles in the modeling bandwidth, excess poles are usually found outside the modeling domain \mathcal{C} . Furthermore, the error between the model responses and the reference data usually does not improve when the number of estimated poles becomes larger than the number of actual poles.

For the present modeling example, the bandwidth of the input pulse, *i.e.*, the modeling bandwidth, is set to 30 GHz. From

the columnwise pole search via 4SID, five similar distributions of poles are found, that are composed of three couples of complex conjugate poles and possibly a real pole, all contained in \mathcal{C} . The similarity of poles estimated from different columns of scattering matrix entries is consistent with the strong coupling between the conductors of the example structure. The adopted pole set is composed of three couples of complex poles and one real pole obtained from the clustering of the five pole distributions. The obtained pole set is then used to define partial fraction expansions for all the scattering matrix entries. The amplitude of all scattering matrix entries for the input data and for our final model are compared in Fig. 3. The good agreement of the model and the reference curves can be clearly appreciated. Deviations mainly occur at the high frequency end of the modeling bandwidth and arise from the influence of the high frequency poles not included in the model. We verified, by using a larger modeling bandwidth, that the example structure has other poles located around 40 GHz that influence the behavior of the scattering data in the 30 GHz bandwidth.

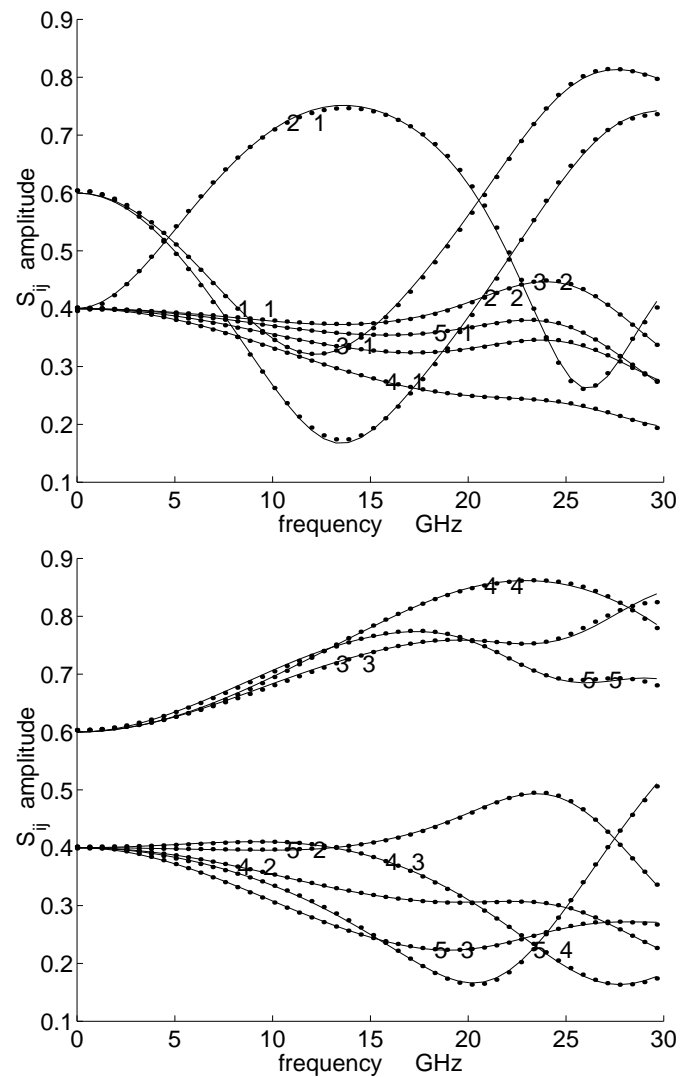

Figure 3: Scattering matrix entry amplitudes of the device of Fig. 2 vs. frequency (curves labelled after the indexes of the entries). Solid lines: reference responses computed for numerical simulation; dots: model responses.

Passivity

Recently the passivity of macromodels has been addressed in several works (*e.g.*, see [1, 11, 5, 4]). In [4], passive models are obtained via Nevalinna-Pick interpolation, that, however, gives no emphasis to the role of device poles. The other proposed approaches, instead, enforce passivity a posteriori, by compensating the estimated model with correction terms or variation of its parameters. Of course, they assume very accurate and hence nearly passive models, so that passivity can be easily obtained by means of small corrections.

A-posteriori methods for enforcing passivity can be easily adapted to a modeling approach based on scattering data. Presently, we are experimenting with the method of [5]. This method is based on the frequency-domain passivity condition, that, for scattering matrices, writes:

$$\begin{aligned} (i) \quad & S(s^*) = S^*(s) \\ (ii) \quad & S(s) \text{ analytic in } \Re\{s\} > 0 \\ (iii) \quad & \|S^+(j\omega)S(j\omega)\| \leq 1 \quad \forall \omega \end{aligned} \quad (4)$$

where $*$ indicates complex conjugate and $+$ conjugate transpose. Since our models satisfy (i) and (ii) by constructions, they are passive iff condition (iii) holds. This is equivalent to

$$\sigma_k(j\omega) \leq 1 \quad \forall \omega, k \quad (5)$$

where $\sigma_k(j\omega)$ are the singular values of $S(j\omega)$. The argument of [5] is that, for small variations of the model parameters, every model characteristics, including σ_k , is a linear function of the variations. Owing to this property, (5) becomes a linear constraints on the variations of the model parameters.

So far, we have successfully applied the constrained variation of model residues to problems where passivity violations occur at a few frequency points, and are caused by one singular value.

For lossless problems, however, all singular values of the scattering matrix are close to one on the entire modeling bandwidth, and passivity violations occur at every frequency. Therefore, in this case the enforcement of passivity via constrained variations is more difficult and further study is required. However, lossless cases where very accurate models are available, can still be handled by a simplistic approach, that is a slight reduction of all residues by the same constant factor (*i.e.*, the attenuation of the model scattering matrix). As an example, the singular values of the model of Fig. 3 are shown in Fig. 4. For frequencies larger than the highest matched frequency, they decay rapidly, because the model is passive at infinity and all its poles are within the modeling bandwidth. In the modeling bandwidth however, all singular values oscillate around the value +1, exceeding it by very small amounts. In this situation, a passive model is obtained by a 1% reduction of the residues of the model of Fig. 3, that causes a marginal loss of accuracy.

Conclusions

We have addressed the modeling of packages via the estimation of their poles. Such an approach can yield low-order highly accurate models. Pole estimation via 4SID appears robust and flexible. It can successfully work on responses computed by fullwave simulators and can be adapted to problems with a large number of ports. Although the enforcement of pas-

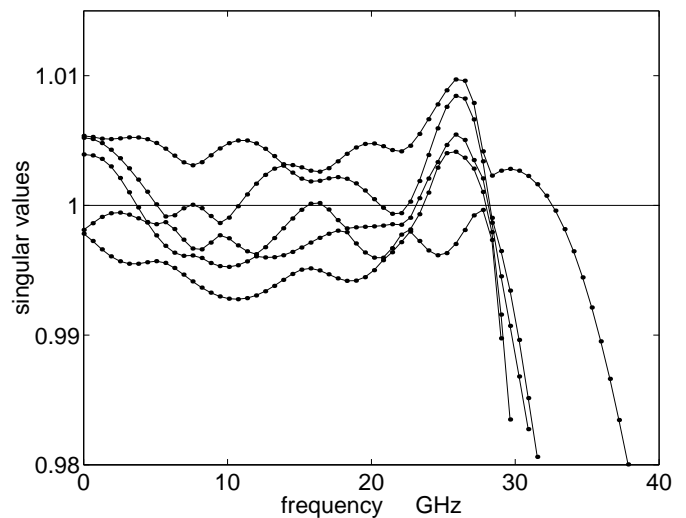

Figure 4: Singular values of the scattering matrix of the model of Fig. 3 vs. frequency.

sivity requires further study, the accuracy of the obtained models allow their compensation for passivity also in the critical case of lossless structures.

Acknowledgments

The help of Dr. E. Leroux (CST) is gratefully acknowledged.

References

- [1] Achar, R. *et Al.*, "Passive interconnect reduction algorithm for distributed/measured networks," *IEEE Trans. Circ. and Sys.—II*, vol. 47, pp. 287–301, Apr. 2000.
- [2] Beyene, W. T., *et Al.*, "Efficient transient simulation of high-speed interconnects characterized by sampled data," *IEEE Trans. CPMT — part B*, vol. 21, pp.105-114, 1998.
- [3] Elzinga, M., *et Al.*, "Pole-residue formulation for transient simulation of high-frequency interconnects using householder LS curve-fitting techniques," *IEEE Trans. CPMT — part B*, vol. 23, pp.142-147, 2000.
- [4] Coelho, C. P., *et Al.*, "Passive constrained rational approximation algorithm using Nevalinna-Pick interpolation," *Proc. DATE 2002*, Paris, France, Mar. 2002, pp.923-930.
- [5] Gustavsen, B., *et Al.*, "Enforcing passivity for admittance matrices approximated by rational functions," *IEEE Tran. Pow. Sys.*, vol. 16, pp.97-104, May 2001.
- [6] F. Canavero, *et Al.*, "Macromodels of packages via scattering data and complex frequency hopping," *Proc. of 5th IEEE Workshop on Signal Propagation on Interconnects*, Venice, I, May 13–16, 2001.
- [7] Viberg, M., "Subspace-based methods for the identification of linear time-invariant systems," *Automatica*, Vol. 31, pp. 1835–1851, 1995.
- [8] Chou, C. T., *et Al.*, "Subspace Algorithms for the Identification of Multivariable Dynamic Errors-in-Variables Models," *Automatica*, Vol. 33, pp.1857–1869, 1997.
- [9] R. Achar, M. Nakhla, "Minimum realization of reduced-order high-speed interconnect macromodels," *Signal Propagation on Interconnects*, H. Grabinski (Ed.), Kluwer Academic Publishers, Boston, 1998, ISBN 0-7923-8275-7.
- [10] CST *MICROWAVE STUDIO (R)* User's Manuals, 2001.
- [11] Morsey, J., *et Al.*, "PRIME: passive realization of interconnect models from measured data," *Proc. 10-th IEEE Top. Meet. EPEP*, Cambridge, MA, Oct. 2001, pp.47-50.