

Testing microwave devices under different source impedances: a novel technique for on-line measurement of source and device reflection coefficients

Original

Testing microwave devices under different source impedances: a novel technique for on-line measurement of source and device reflection coefficients / Ferrero, A.P., Madonna, G., Pirola, M., Pisani, U.. - In: IEEE TRANSACTIONS ON INSTRUMENTATION AND MEASUREMENT. - ISSN 0018-9456. - im-49:(2000), pp. 285-289. [10.1109/19.843065]

Availability:

This version is available at: 11583/1404418 since:

Publisher:

IEEE

Published

DOI:10.1109/19.843065

Terms of use:

This article is made available under terms and conditions as specified in the corresponding bibliographic description in the repository

Publisher copyright

(Article begins on next page)

Testing Microwave Devices under Different Source Impedances: a Novel Technique for On-Line Measurement of Source and Device Reflection Coefficients

G.L.Madonna, M.Pirola, A.Ferrero and U.Pisani

Dipartimento di Elettronica

Politecnico di Torino,

Corso Duca degli Abruzzi 24, 10129 Torino, Italy

ferrero@polito.it

Abstract

This paper describes a new approach for fast and accurate determination of the source reflection coefficient in microwave source-pull measurements. To the authors' knowledge, this is the only technique that allows the simultaneous measurement of the source and the DUT gammas. A traditional vector network analyzer is used as a three-channel receiver. The calibration procedure is based on a new reflectometer model that extends the traditional error box concept. Experimental results are presented and compared to data obtained with traditional techniques.

1. Introduction

Microwave source-pull measurement techniques consist in monitoring the desired performance of a device under test (DUT) while driving it with different source impedances. This approach is widely used for microwave active device characterization, both in small and large signal conditions. A typical application is low noise amplifier (LNA) design to experimentally obtain the optimum noise impedance [1] or the matching network for mixers, oscillators and high efficiency amplifiers [2 - 4].

To complete an accurate characterization of the DUT in a reasonable time, both automatic source impedance setting and measurement capabilities are mandatory. Different systems have been proposed for the former need, based on either passive tuners [2, 4] or active-load techniques [3, 5 - 7]. This paper mainly deals with the second topic, i.e. the fast and accurate determination of the source impedance along with the measurement of the DUT input characteristics.

The well-known problem definition is shown in figure 1. Traditional measurement systems are able to obtain calibrated values of a and b and their ratio

$$\Gamma_L = \frac{b}{a} \quad (1)$$

On the other side, the source reflection coefficient we are looking for is defined as

$$\Gamma_s = \frac{a}{b} \left(1 - \frac{a_s}{a} \right) \quad (2)$$

and it is equal to ratio a/b only if $a_s = 0$, i.e. the internal generator is switched off.

A simple technique consists in switching the microwave generator off and measuring the equivalent source reflection coefficient by exciting the test-set back from the DUT port. This solution is accurate, but it cannot be used for automatic characterization since it requires disconnecting the DUT at each tuner position.

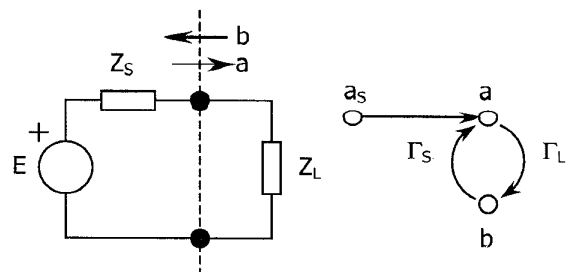

Figure 1. Definition of the problem.

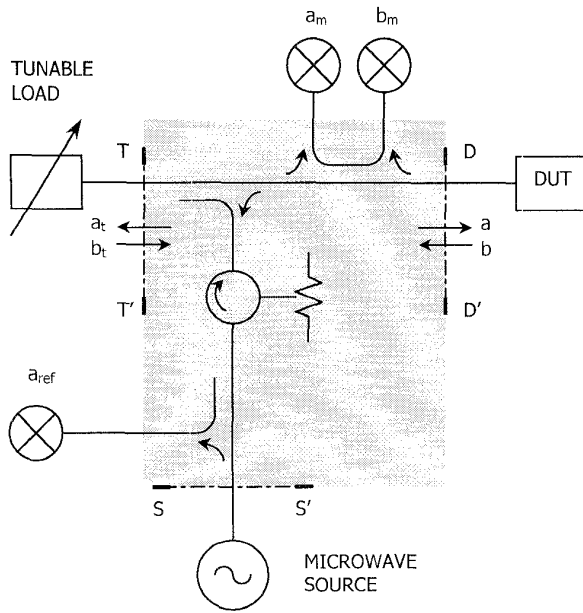

Figure 2. Simplified block scheme of the source-pull measurement test-set.

A completely different approach is described in [1], where the reflection coefficient of the tuning element is continuously monitored by a six-port reflectometer in reverse configuration. This technique is both accurate and suitable for automatic source pulling; however, the problem is just diverted, since now it is the DUT reflection coefficient that cannot be determined.

The solution recently proposed in [6] is probably the most effective, since it allows the accurate measurement of both the DUT and the source reflection coefficient, but – again – two distinct acquisition steps are necessary.

This paper describes a novel solution based on a three-sampler vector network analyzer (VNA). The test-set is shown in figure 2 and it is analogous to the systems described in [1, 6]. The signal from a microwave synthesized source is summed with the wave reflected by the tuning element and injected into the DUT. Signal a_{ref} is drawn from the generator output to provide a stable reference to the receiver and a terminated circulator is used to guarantee isolation of the microwave synthesizer.

The main breakthrough is that, after the new calibration procedure here described, the measurements of waves a_m and b_m with respect to a_{ref} are sufficient to determine source and DUT reflection coefficients, respectively Γ_S and Γ_L .

The interesting features of the novel technique are:

- a new model for the input reflectometer, which extend the well-known *error-box* concept [8];

- a new calibration procedure, based on traditional one port standard devices;
- simultaneous measurements of the source and the DUT gammas; in particular:
 - it is not necessary to disconnect the DUT to measure the source gamma;
 - it is not necessary to switch the microwave source off, nor to disconnect it.

2. Calibration procedure

2.1. Theoretical aspects

The novel error model is shown in figure 3. The flow graphs of figure 3a and 3b are derived from classical load-pull theory [9], [10]. They allow to link the waves a , b at the DUT reference plane with the measured quantities a_m , b_m and, simultaneously, the same a , b with the wave a_t , b_t at the tuner plane T-T' (see figure 2).

Flow graph of figure 3c represents the key point of the new model. The waves at the tuner plane (a_t , b_t) when the source is turned on are written as a linear function of all three measured quantities, a_m , b_m and a_{ref} . This leads to a novel concept of error-box, which extends the original idea to include the source terms represented by a_{ref} .

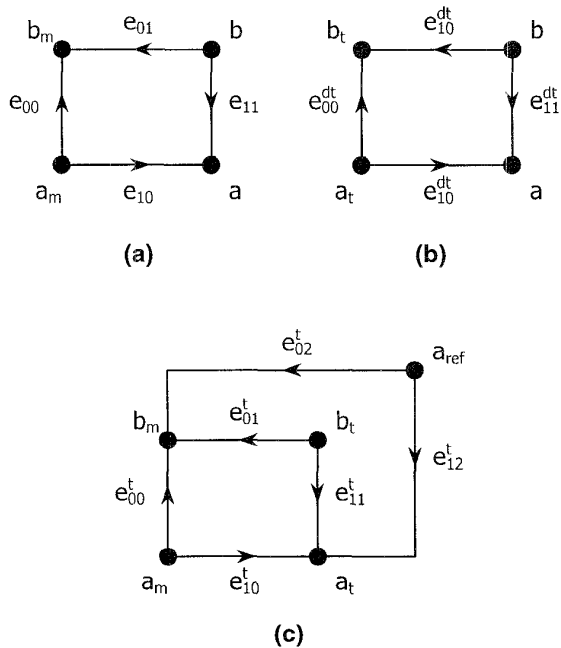

Figure 3. Error model.

2.2. Calibration sequence and de-embedding

Table 1 shows the connection sequence of the standard devices whose measurements are sufficient to compute all the error coefficients. The entire set of connections is divided into two subsets. First, source is plugged to section S-S' and standard connections from 1 to 6 are made. Afterwards, the microwave source is turned to the DUT port and three additional standards are connected to shift the reference plane from section T-T' to D-D'.

	DUT plane D – D'	Tuner plane T – T'	Source plane S – S'
1	SHORT	SHORT	source
2	SHORT	OPEN	source
3	SHORT	LOAD	source
4	OPEN	SHORT	source
5	OPEN	LOAD	source
6	LOAD	LOAD	source
7	source	SHORT	LOAD
8	source	OPEN	LOAD
9	source	LOAD	LOAD

Table 1. Sequence of standard devices and relative position of the microwave source signal.

De-embedding is carried out in three distinct steps:

1. DUT reflection coefficient Γ_L at section D-D' is computed by the error coefficient of figure 3b;
2. tuner reflection coefficient Γ_t at section T-T' is computed by the error box of figure 3a;
3. the same Γ_t is shifted to the DUT reference plane D-D'; the result is proved to be the source reflection coefficient Γ_S .

3. Experimental results

Measurement results are shown in figures from 4 to 6. Source reflection coefficient is limited in magnitude, since a simple passive tuner was used. To validate the novel technique, various gammas source were measured under different conditions. For each tuner position:

- first gamma source was directly measured with a VNA at DUT port and the source switched off, yielding $\Gamma_{S,0}$;
- then, a short was connected to the DUT port to simulate an high-impedance device and gamma

source was computed by the described technique at two different source output power levels (10 and 0 dBm), obtaining respectively $\Gamma_{S,1}$ and $\Gamma_{S,2}$.

Results computed for a single tuner setting are shown in figure 4 as a function of frequency. $\Gamma_{S,1}$ and $\Gamma_{S,2}$ plots overlap, proving that the technique de-embeds the same Γ_S for different values of stimulus a_S . Moreover, they show only small differences with respect to $\Gamma_{S,0}$, as pointed out in figure 5. Finally, figure 6 shows various source gammas obtained at single frequency for different tuner positions.

4. Conclusions

A new calibration technique has been presented, which allows to obtain simultaneous corrected measurements of the source and the device input impedance for fast microwave characterization. Experimental results prove the accuracy of the proposed method against the traditional techniques.

References

- [1] D.L. Le and F.M. Ghannouchi, "Noise measurements of microwave transistor using uncalibrated mechanical stub tuner and a built-in reverse six-port reflectometer," *IEEE Trans. Instrument Meas.*, vol. IM-44, pp.847-852, Aug. 1995.
- [2] F.M. Ghannouchi and R. Bosisio, "Source-pull/load-pull oscillator measurements at microwave/mm wave frequencies," *IEEE Trans. Microwave Theory Tech.*, vol. MTT-41, pp. 32-35, Feb. 1992.
- [3] D.L. Le and F.M. Ghannouchi, "Multitone characterization and design of FET resistive mixers based on combined active source-pull/load-pull techniques," *IEEE Trans. Microwave Theory Tech.*, vol. MTT-46, pp. 1201-1208, Sep. 1998.
- [4] C. Tsironis, "A novel design method of wideband power amplifier," *Microwave J.*, pp. 303-304, May 1992.
- [5] G.P. Bava, U. Pisani and V. Pozzolo, "'Source pull' technique at microwave frequencies," *Electronic Lett.*, vol.20, n.4, pp. 152-154, Feb. 1984.
- [6] G. Berghoff, E. Bergeault, B. Huyart and L. Jallet, "Automated characterization of HF power transistor by source-pull and multiharmonic load-pull measurements based on six-port techniques," *IEEE Trans. Microwave Theory Tech.*, vol. MTT-46, pp. 2068-2073, Dec. 1998.
- [7] D.L. Le, P. Poiré and F.M. Ghannouchi, "Six-port-based active source-pull measurement technique," *Meas.Sci.Technol.*, vol.9, pp. 1336-1342, Aug. 1998.
- [8] H.J.Eul and B.Schieck, "A generalized theory and new calibration procedures for network analyzer self-calibration," *IEEE Trans. Microwave Theory Tech.*, vol. MTT-39, pp. 724-731, Apr. 1991.

[9] I. Hecht, "Improved error-correction technique for large-signal load-pull measurement," *IEEE Trans. Microwave Theory Tech.*, vol. MTT-35, pp. 1060-1062, Nov. 1987.

[10] A. Ferrero and U. Pisani, "An improved calibration technique for on-wafer large-signal transistor characterization," *IEEE Trans. Instr. Meas.*, vol. IM-42, pp. 360-364, Apr. 1993.

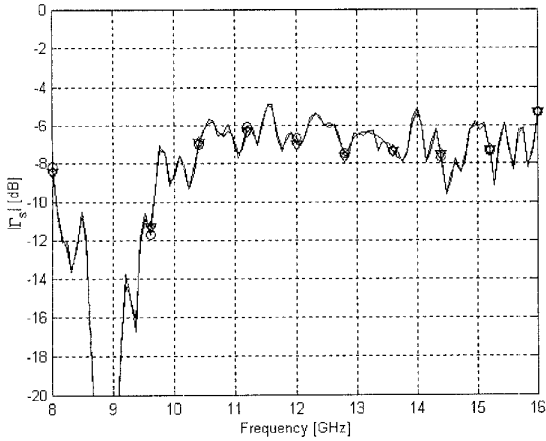

Figure 4. Source gamma for tuner position 2 (see also figure 6): $\Gamma_{s,0}$ (VNA: \circ), $\Gamma_{s,1}$ (new technique, with source power at 10 dBm: ∇), $\Gamma_{s,2}$ (new technique, with source power at 0 dBm: \diamond).

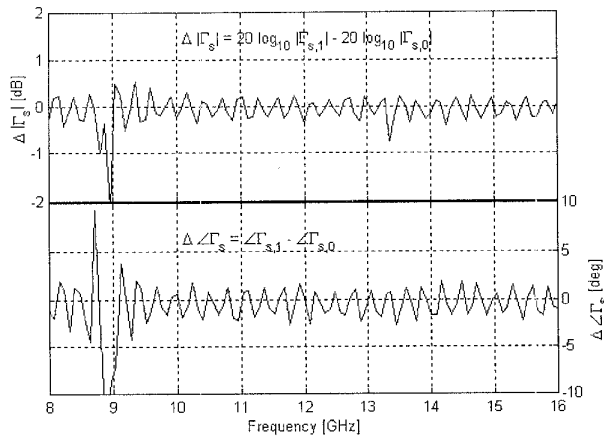

Figure 5. Differences between source gammas computed by different techniques. Degradation of phase accuracy is evident for $|\Gamma_s| < 20$ dB, where phase is no more significant.

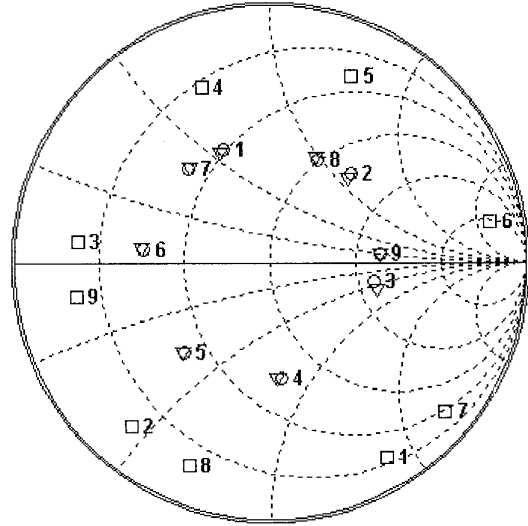

Figure 6. Source reflection coefficient at 12GHz for various tuner positions computed by different techniques: $\Gamma_{s,0}$ (VNA: \circ), $\Gamma_{s,1}$ (new technique, with source power at 10 dBm: ∇). Squares (\square) represent the corresponding tuner input gamma at section T-T': reflectometer attenuation and phase shift are evident.