

A new class of nonuniform, broadband, nonsymmetrical rectangular coaxial-to-microstrip directional couplers for high power applications

Original

A new class of nonuniform, broadband, nonsymmetrical rectangular coaxial-to-microstrip directional couplers for high power applications / Teppati, Valeria; Ferrero, ANDREA PIERENRICO. - In: IEEE MICROWAVE AND WIRELESS COMPONENTS LETTERS. - ISSN 1531-1309. - STAMPA. - 13:4(2003), pp. 152-154. [10.1109/LMWC.2003.811066]

Availability:

This version is available at: 11583/1400352 since:

Publisher:

Published

DOI:10.1109/LMWC.2003.811066

Terms of use:

This article is made available under terms and conditions as specified in the corresponding bibliographic description in the repository

Publisher copyright

(Article begins on next page)

A New Class of Nonuniform, Broadband, Nonsymmetrical Rectangular Coaxial-to-Microstrip Directional Couplers for High Power Applications

Valeria Teppati, *Student Member, IEEE*, and Andrea Ferrero, *Member, IEEE*

Abstract—An innovative class of coaxial-to-microstrip broad-band high power directional couplers is studied. The new devices overcome the drawbacks of both stripline and coaxial couplers and allow simple and low cost mechanical construction.

In this letter, we present the design, realization and characterization of a set of broad-band (900 MHz to 5.5 GHz) low coupling (−30 dB, −40 dB) directional couplers with directivity of more than 10 dB over the whole band, demonstrating good agreement between predicted and obtained performances.

Index Terms—Broad-band couplers, coaxial cables, coaxial couplers, microstrip couplers, nonuniform couplers, stripline couplers.

I. INTRODUCTION

DIRECTIONAL couplers are key components in many RF applications, in particular for the realization of test setups.

Nowadays, off-the-shelf devices are stripline couplers, waveguide couplers and coaxial couplers. Stripline or microstrip couplers are well suited for broad-band applications [1]–[3]; unfortunately their significant losses can prevent their use when high power handling is required. Waveguide Bethe-hole couplers [4] are used in high power applications, but are not a practical solution for broad-band use, even though many techniques have been proposed for this purpose [5]–[7], since the primary mode is limited at low frequencies by the cutoff frequency and the higher order modes limit the upper frequency. Eventually, coaxial directional couplers in air are the traditional high power solution when bandwidth specifications are not critical [8] and would be ideal for their low losses, their TEM field configurations ensuring zero cutoff frequency, and their high power handling capabilities.

In order to obtain coaxial structures with bandwidths competitive with stripline and microstrip devices and presenting minimum discontinuities, it is necessary to properly design a continuous variation of the coupling factor \mathcal{K} along the propagation direction z .

The new solution proposed in the present work is a coaxial-to-microstrip coupler. The rectangular nonsymmetrical coaxial main line is coupled to a microstrip through an aperture on the ground plane of the dielectric substrate, as shown in Fig. 1. Out-

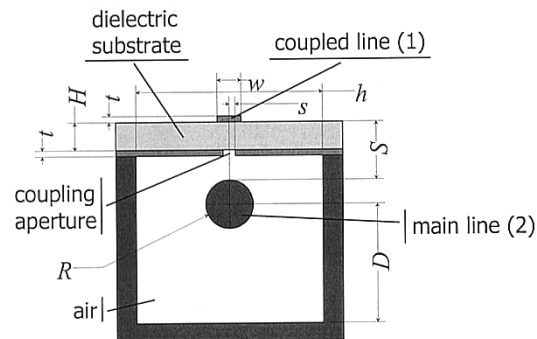

Fig. 1. Cross section of a rectangular coaxial-to-microstrip coupler. The main line, of radius R , and coupled line, a microstrip of width w , are coupled through an aperture (having half width s) on the bottom side of the microstrip substrate.

side the coupling region, the matched rectangular coaxial transmission line in air grants lower loss and higher power handling capability with respect to classical stripline couplers. The aperture width varies along the longitudinal direction z , in order to obtain the desired frequency profile of the coupling factor. This aperture can be easily realized with accurate and inexpensive photo-etching techniques, thus fabricating couplers with excellent repeatability, good directivity, and bandwidths as large as required.

II. COUPLER DESIGN, FABRICATION, AND CHARACTERIZATION

The new, broad-band coupler design is based on the quasistatic assumption, that decouples the longitudinal and transversal electromagnetic problems. Thus, the evaluation of cross section per-unit-length electrical equivalent as function of the geometrical parameters is the first step for the coupler design.

This computation has been performed with an accurate 2-D Finite Element Method (FEM) algorithm, providing all the information on per unit length capacitance and inductance matrices as functions of the structure dimensions, as shown in Fig. 2.

The cross section electrical equivalent parameters of Fig. 2 are polynomially fitted and used to compute the scattering matrix (function of s) of a coupler of finite length Δz . With this information, the frequency response of a nonuniform coupler having aperture s varying along z can be computed. The required aperture profile $s(z)$, needed to realize the desired frequency response, is obtained with an optimization technique, on the basis of the methodology for nonuniform ultra broad-band stripline couplers presented in [9], [10]. This approach has been

Manuscript received August 3, 2002; revised October 16, 2002. The review of this letter was arranged by Associate Editor Dr. Rüdiger Vahldieck.

The authors are with the Dipartimento di Elettronica, Politecnico di Torino, I-10129 Torino, Italy (e-mail: valeria.teppati@polito.it).

Digital Object Identifier 10.1109/LMWC.2003.811066

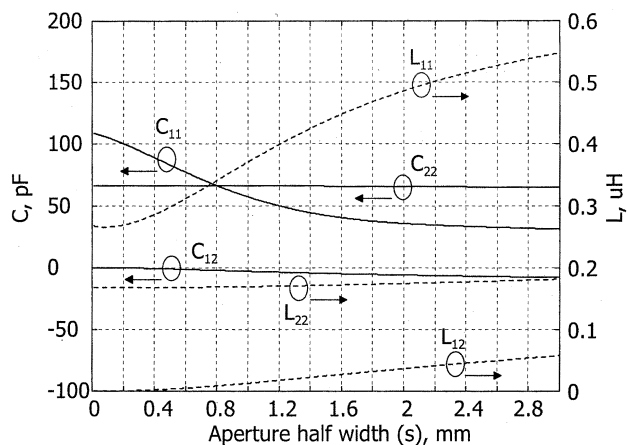

Fig. 2. Elements of the per unit length capacitance (continuous lines) and inductance (dashed lines) matrices, versus aperture half width s for the realized couplers (1: coupled line, 2: main line). Cross section dimensions (see Fig. 1) are $R = 3.5$ mm, $h = 15$ mm, $D = 20$ mm, $t = 70$ μm , $S = 3.078$ mm, $H = 508$ μm , and $w = 1.15$ mm.

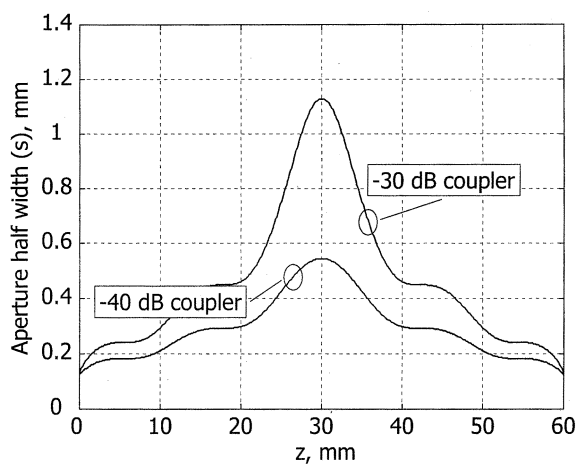

Fig. 3. Designed aperture half width s versus longitudinal direction z for the two realized couplers.

revised, implemented in MATLAB and applied to the novel coaxial-microstrip structures.

The set of broad-band couplers designed and realized with the proposed methodology is composed by a rectangular coaxial structure plus two different dielectric substrates, for coupling coefficients of respectively -30 and -40 dB in the band from 900 MHz to 5.5 GHz. The maximum coupling achievable with these novel structures is mainly limited by the realization technology and mechanical tolerances, determining the distance S . For the realized structure, the maximum coupling coefficient obtainable was of about -20 dB.

It would be possible to extend the band to lower frequencies, by increasing the coupler length, which has been chosen to be 60 mm. The limitation to the upper frequency instead is mainly imposed by the substrate material losses.

The resulting aperture variation versus z , $s(z)$, is shown in Fig. 3 for the two couplers. Schemes of the realized substrate bottoms are shown in Fig. 4. Apart from the aperture width s , which varies along z , the designed structure has the following transversal dimensions (refer to Fig. 1): $R = 3.5$ mm, $h = 15$ mm, $D = 20$ mm, $t = 70$ μm , $S = 3.078$ mm, $H = 508$ μm ,

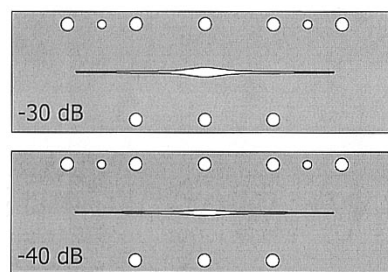
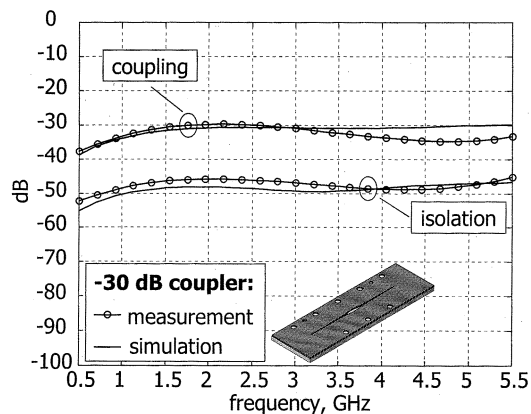
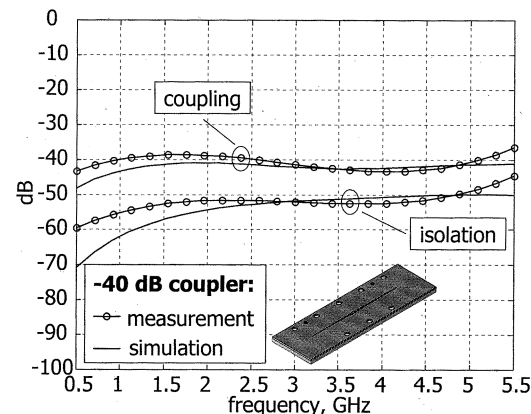

Fig. 4. Schemes of the substrate bottoms for the two realized couplers.



(a)



(b)

Fig. 5. Measurements and simulations of $\mathcal{K}(f)$ and $\mathcal{I}(f)$, coupling and isolation coefficients versus frequency, for the realized directional couplers: (a) -30 dB coupler (b) -40 dB coupler. Measurements are highlighted with circles.

and $w = 1.15$ mm. These dimensions were chosen in order to grant that both the main line and the microstrip have 50 Ω characteristic impedances when the aperture width is reduced to zero to facilitate impedance matching at the connector interfaces. The choice of $R = 3.5$ mm allows the main coaxial line to be interfaced with the 7/16 series of coaxial high power connectors limiting mismatching losses. The substrate for the microstrip has 508 μm height, with dielectric constant $\epsilon_r = 3.2$ and copper thickness of 70 μm .

Finally, 4-ports scattering parameters measurements of the couplers have been performed with a three port Vector Network Analyzer. In Fig. 5, the calibrated measurements and the simulation results are shown. The measured coupling coefficient $\mathcal{K}(f)$

(circles) for the two different couplers shows good agreement with the expected coupling. The measured coupler directivity is more than 10 dB over the whole band, thus comparable to many stripline commercial couplers (10–15 dB). The measured return loss (S_{11}) and insertion loss (S_{21}) over the bandwidth of 0.5 to 5.5 GHz is greater than 17 dB and less than -0.4 dB, respectively.

The maximum power injectable before the dielectric breakdown occurs has been computed. FEM field simulation have been performed as function of the aperture width for the realized structure. By assuming dry air dielectric breakdown field of 3000 kV/m and under matching conditions, the maximum bearable power is of about 30 kW.

III. CONCLUSION

A new set of coaxial-to-microstrip coupling structures has been proposed and analyzed, in order to overcome the main drawbacks of coaxial, waveguide, and stripline couplers. These structures represent a great improvement for high power measurement systems, since they have broad-bands, good directivity, and can be easily designed and fabricated.

A set of broad-band coupler prototypes has been constructed and measured, showing good agreement with the simulations, confirming the validity of the proposed design methodology and

demonstrating the attractive characteristics of this new design approach.

REFERENCES

- [1] D. K. Y. Lau, S. P. Marsh, L. E. Davis, and R. Sloan, "Simplified design technique for high-performance microstrip multisection couplers," *IEEE Trans. Microwave Theory Tech.*, vol. 46, pp. 2507–2513, Dec. 1998.
- [2] J. L. B. Walker, "Analysis and design of Kemp-type 3 dB quadrature couplers," *IEEE Trans. Microwave Theory Tech.*, vol. 38, pp. 88–90, Jan. 1990.
- [3] S. Uysal and H. Aghvami, "Synthesis, design, and construction of ultra-wide-band nonuniform quadrature directional couplers in inhomogeneous media," *IEEE Trans. Microwave Theory Tech.*, vol. 37, pp. 969–976, June 1989.
- [4] R. E. Collin, *Foundations for Microwave Engineering*, 2nd ed. New York: McGraw-Hill, 1992.
- [5] H. Schmiedel and F. Arndt, "Field theory design of rectangular waveguide multiple-slot narrow-wall couplers," *IEEE Trans. Microwave Theory Tech.*, vol. MTT-34, pp. 791–798, July 1986.
- [6] H. J. Riblet, "The short-slot hybrid junction," *Proc. IRE*, vol. 40, pp. 180–184, Feb. 1952.
- [7] L. T. Hildebrand, "Results for a simple compact narrow-wall directional coupler," *IEEE Microwave Guided Wave Lett.*, vol. 10, pp. 231–232, June 2000.
- [8] A. H. McCurdy and J. J. Choi, "Design and analysis of a coaxial coupler for a 35-GHz gyrokystron amplifier," *IEEE Trans. Microwave Theory Tech.*, vol. 47, pp. 164–175, Feb. 1999.
- [9] L. Young, Ed., *Parallel Coupled Lines and Directional Couplers*. Norwood, MA: Artech House, 1972.
- [10] S. Uysal, Ed., *Nonuniform Line Microstrip Directional Couplers and Filters*. Norwood, MA: Artech House, 1993.