

Assessing the viability of dynamic wireless power transfer in long-haul freight transport: A techno-economic analysis from fleet operators' standpoint

Original

Assessing the viability of dynamic wireless power transfer in long-haul freight transport: A techno-economic analysis from fleet operators' standpoint / Costantino, Trentalessandro; Miretti, Federico; Spessa, Ezio. - In: APPLIED ENERGY. - ISSN 0306-2619. - ELETTRONICO. - 379:(2025). [10.1016/j.apenergy.2024.124839]

Availability:

This version is available at: 11583/2994747 since: 2024-11-25T09:12:20Z

Publisher:

Elsevier

Published

DOI:10.1016/j.apenergy.2024.124839

Terms of use:

This article is made available under terms and conditions as specified in the corresponding bibliographic description in the repository

Publisher copyright

(Article begins on next page)

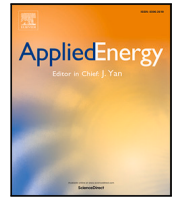

Assessing the viability of dynamic wireless power transfer in long-haul freight transport: A techno-economic analysis from fleet operators' standpoint

Trentalessandro Costantino*, Federico Miretti, Ezio Spessa

DENERG - Department of Energy "Galileo Ferraris", CARS@Polito - Center for Automotive Research and Sustainable Mobility, Politecnico di Torino, C.so Duca degli Abruzzi, 24, Torino, TO 10129, Italy

ARTICLE INFO

Keywords:

Total cost of ownership
Heavy duty
Electric trucks
eRoad
ERS

ABSTRACT

This study presents a techno-economic assessment of dynamic wireless power transfer for long-haul freight transport, focusing on the fleet operator's perspective. In particular, we compared three different powertrain technologies: a conventional powertrain and a battery-electric with or without a dynamic charger installed. For all three technologies, we developed a cost model to assess the total cost of ownership for a fleet operator using different scenarios.

Notably, dedicated cost models were devised to estimate energy carrier costs and costs related to time loss incurred by fleet operators due to extended delivery times of electric trucks compared to conventional ones. The novelties in the cost model are twofold. First, dedicated cost models have been devised to estimate the costs related to the energy carriers (including the cost of infrastructure) and to the time loss incurred by fleet operators due to the extended delivery times of electric trucks compared to conventional ones. Second, the energy consumption by source and travel time were derived from an ad-hoc developed simulation approach models longitudinal dynamics of the case-study as well as the powertrain's performance on the basis of experimentally derived look-up tables provided by manufacturers as well as by previous research projects. The simulation results provided by this model are instrumental to our enhanced cost model as it provides the required inputs and it allowed us to tailor the results to a specific delivery mission.

Our results provide valuable insights for fleet operators considering the adoption of zero-emission trucks and to policy-makers and other infrastructure stakeholders regarding the conditions required for the cost-effectiveness of electric road systems.

1. Introduction

1.1. The regulatory drive for electrification of heavy-duty transport

Trucks, buses, and coaches collectively account for over a quarter of greenhouse gas (GHG) emissions from road transport in the European Union (EU) and account for over 6% of total EU GHG emissions. Despite some recent efficiency improvements, emissions continue to rise, primarily attributed to the escalating volume of road freight traffic. Therefore, in 2019, the European Commission implemented a regulation aimed at significantly reducing carbon dioxide emissions from heavy-duty trucks and buses. The regulation sets targets of reducing the average fleet carbon dioxide (CO₂) emissions by 15% by 2025, compared to the 2019 baseline, and by 30% by 2030 [1]. Initially, the vehicles required to certify their CO₂ emissions are those belonging to vehicle groups 4, 5, 9, and 10, which corresponds to rigid and tractor trucks with 6 × 2 axle configuration or a 4 × 2 configuration and

a technically permissible maximum mass exceeding 16 tonnes. These groups covered approximately 64% of heavy duty vehicle (HDV) sales in 2019.

Furthermore, in 2024, new CO₂ emission reduction targets have been set for large trucks, coaches and inter-urban buses, namely 45% for the period 2030–2034, 65% for 2035–2039, and 90% as of 2040. By 2030, new urban buses will need to reduce their CO₂ emissions by 90% and become zero-emission vehicles by 2035 [2].

Manufacturers are mandated to monitor and report CO₂ emissions and fuel consumption data to the European Commission for every new vehicle intended for the EU market. This result is assessed according to certification regulations and calculated using the Vehicle Energy Consumption Calculation Tool (VECTO). Failure to meet CO₂ targets may result in financial penalties imposed by the Commission, set at 4250 EURO per gCO₂/t*km in 2025 and 6800 EURO per gCO₂/t*km

* Corresponding author.

E-mail addresses: trentalessandro.costantino@polito.it (T. Costantino), federico.miretti@polito.it (F. Miretti), ezio.spessa@polito.it (E. Spessa).

<https://doi.org/10.1016/j.apenergy.2024.124839>

Received 10 May 2024; Received in revised form 23 October 2024; Accepted 31 October 2024

Available online 18 November 2024

0306-2619/© 2024 The Authors. Published by Elsevier Ltd. This is an open access article under the CC BY license (<http://creativecommons.org/licenses/by/4.0/>).

Nomenclature

AT_y	Annual added time
CF_n	Net cash flow
E_y	Annual energy consumption
ES_y	Annual energy sold
h_d	average daily working hours
W_y	working days in a year
η	Efficiency
BEV	Battery electric vehicle
CAPEX	Capital expenditure
CO ₂	Carbon dioxide
DWPT	Dynamic wireless power transfer
ERS	Electric road system
EU	European Union
FCEV	Fuel cell electric vehicle
GHG	Greenhouse gases
HDV	Heavy duty vehicle
ICEV	Internal combustion engine vehicle
IRR	Internal rate of return
JL	fraction of journey lost
L	Time penalty cost
LH	Long haul
MCS	Megawatt charging system
NPV	Net present value
OPEX	Operational expenditure
P	Power
R	Minimum revenue
RV	Residual value
SOC	State of charge
TCO	Total cost of ownership
UT	Utilization ratio
VAT	Value added tax
VECTO	Vehicle energy consumption calculation tool

in 2030. As a consequence, the introduction of carbon-free vehicles to the market will become increasingly important in the coming years.

Regarding carbon-free vehicles, since the approved regulations only account for tailpipe carbon dioxide emissions, the only viable options to achieve the ambitious target are to introduce battery electric vehicles (BEVs) and fuel cell electric vehicles (FCEVs). Indeed, these two technologies are the sole options with zero emissions through the tailpipe. Consequently, in recent years, electric vehicles have experienced a surge in sales, doubling in 2021 to reach a record of more than two million units sold in a single year. Moreover, In 2021, several major automakers announced plans to move toward the transition to a fully electric future with new product lines as well as converting existing manufacturing capacity. On the other hand, the fuel cell electric vehicle nowadays does not represent a significant percentage in sales due to the higher cost compared with a battery electric vehicle [3] and there are many doubts about their cost effectiveness and viability. Another crucial consideration is the infrastructure required. As manufacturers increasingly focus on full electrification with BEVs in the passenger car market, the infrastructure for BEVs could be shared with freight transport, given their compatibility. However, FCEVs would necessitate separate infrastructure. Over the past few years, numerous studies have explored the potential of BEVs in reducing greenhouse gas (GHG) emissions compared to conventional vehicles, as well as compared to FCEVs [4–6]. Each study demonstrated that a BEV can sensibly reduce the carbon dioxide equivalent emitted even if we consider the entire

life cycle even when a BEV is compared to an FCEV. Therefore, from an environmental point of view, the BEV may be the key to reducing the impact of climate change on the transport sector, particularly on the road sector with passenger cars and heavy-duty vehicles. However, despite the environmental benefits, numerous economic and technological barriers currently hinder the feasibility of widespread adoption of BEVs, especially for long-haul transport. These barriers must be addressed to realize the full potential of BEVs in reducing emissions and combating climate change effectively.

1.2. Techno-economic barriers for electric trucks

Long-haul freight transport presents unique challenges, including the requirement for extensive daily travel distances and high-powered powertrains to accommodate the substantial size and weight of trucks. European regulations that address driver safety impose limitations on the daily mileage of long-haul trucks. These regulations dictate a maximum daily driving time of 9 hours [7], roughly translating to a maximum of 600 km per day for long-haul freight transport. Consequently, range and charging times present significant challenges, making widespread electrification nearly impossible in the sector. Notably, the heavy-duty sector struggles with two major issues: the demand for long-range capabilities and high payload capacity, both of which are complex and conflicting goals when it comes to BEVs. Pursuing a long-range necessitates using large battery packs, which may reduce the payload capacity and profitability. Moreover, large battery packs significantly impact the retail price of the trucks.

Additionally, the current charging infrastructure is limited by the prototype-level technology of charging stations, such as Megawatt Charging Systems (MCS). A potential solution to address these challenges lies in Electric Road Systems (ERS), also known as eRoads. ERS encompasses various technologies that enable recharging the vehicle's batteries while driving, thus extending the range without excessively increasing battery size.

Consequently, fleet operators are interested in reducing stops at charging stations and overcoming range anxiety, both of which can be achieved through the implementation of ERS. The benefits of ERS can be observed in two ways: reduced charging stops, extending the range, and the ability to right-size the battery pack, resulting in reduced weight. A reduced battery weight leads to increased payload capacity and lower purchase costs for fleet operators. Since the battery contributes significantly to the total cost of purchasing a BEV, its downsizing in an ERS-equipped scenario brings about reduced battery replacement costs. Furthermore, the decreased battery weight minimizes the payload capacity loss when compared to conventional trucks, thereby closing the competitiveness gap for battery-electric vehicles in long-haul freight transportation.

From an environmental perspective, reducing the battery weight results in a decreased demand for critical materials and minerals used in battery manufacturing. Electric Road Systems (ERS) encompass several technologies, such as conductive power transfer through overhead power lines (pantograph and catenary), conductive transfer via in-road rails, and inductive transfer using inductive coils [8]. Among these options, the inductive technology, known as dynamic wireless power transfer (DWPT), has garnered significant attention due to its potential grid-to-load efficiency of up to 90% [9]. In a case study [10] for passenger cars considering the highway fuel economy test (HWFET2) driving cycle, a range extension of 10%–20% was predicted with 20% eRoad coverage and 10 kW charging power. Even greater benefits are achieved with increased eRoad coverage and charging power. Real-world test environments have seen the deployment of various DWPT systems, including the on-line electric vehicle (OLEV) project in Korea [11], the feasibility analysis and development of on-road charging solutions for future electric vehicles FABRIC project in Italy [12,13], and the PRIMOVE project in Germany [14].

Recent research suggests that with an appropriate deployment strategy, ERS infrastructure can even achieve cost parity for fleet operators compared to conventional diesel powertrains [15]. ERSs provide the greatest advantages on highly trafficked highways, where consistent driving at relatively constant speeds is feasible and desirable. This scenario is also where ERSs are most likely to have a viable business model. A study focused on Sweden and Norway [8] identified busy city-to-city connections and freight-intensive local routes as the most suitable roads for ERS implementation from a techno-economic perspective. Nevertheless, a comprehensive analysis that puts together the economic and technological aspects of implementing ERS infrastructure in freight transport, especially from the perspective of fleet operators, has not been found in the existing literature. The study by [15] makes certain assumptions about the impact of ERS on the SOC of HDVs. However, it does not include actual simulations to investigate the vehicle's energy consumption on electrified roads. In contrast, our study develops a robust simulation model directly linked to a cost model, enabling a comprehensive assessment of the three ERS technologies. [8] provides an in-depth analysis of the economic aspects of building electrified road infrastructure in Sweden. However, this study does not integrate technical factors such as available range and delivery time into the economic analysis. Additionally, [8] does not focus on a specific vehicle category, instead referring generically to light and heavy-duty vehicles. In contrast, our study simulates a specific heavy-duty vehicle using the VECTO long-haul drive cycle, providing more specific and applicable insights. [16,17] assess the economic viability of a DWPT system through a public-private partnership, therefore the study is not focused from the fleet operator point of view. Furthermore, there is no link to powertrain simulation. Finally, [18] includes a simulation model inside the economic evaluation but it includes value for light-duty vehicles and does not include the effect of road grade, as we did in our study.

This work presents a techno-economic assessment on a real case study considering a 4×2 long haul truck (VECTO group 5-LH) driving in a highway scenario. The choice fell on a truck belonging to group VECTO group 5 because it represents the vast majority of the trucks sold in Europe [19]. Furthermore, the VECTO group 5 is used most (90% of the sold vehicles) for long-haul missions, making it the most used for these specific purposes. The objective of the study is to compare, through techno-economic analysis, the two alternative propulsion technologies (BEV and DWPT-BEV) while also including a conventional vehicle as a reference baseline. Thus, first, a simulation model is developed to reflect the specific characteristics of the vehicle considered. To include the possibility for a battery truck, if enabled for wireless charging, to recharge its battery packs while on the road, the VECTO long-haul driving cycle is modified to include ERS segments. The effect of the ERS segment length, the vehicle speed while driving in the ERS segment, and the nominal power of the dynamic charger on the vehicle's range is discussed. Details on the developed simulation model are also provided. Simulation results provide the two best scenarios that make ERS technically feasible compared with BEV and conventional internal combustion engine (ICEV) technology, considering the range and delivery time. A complete total cost of ownership was carried out considering every cost that occurred in the truck's lifetime, divided into several cost categories. A comparison with the fast-charging infrastructure, from a techno-economic point of view, was also developed considering the different tolls and the change in delivery times incurred using the two technologies compared to a conventional truck. Fast-charging infrastructure and DWPT tariff were estimated through data related to the construction cost from the literature and real data on electricity in Europe. Furthermore, a sensitivity analysis of the occupation ratio was carried out, explaining the possible tariff variation as a function of the number of vehicles using the specific charging technology, the initial investment by the infrastructure owner, and the electricity cost (i.e., fast charging station, dynamic wireless power transfer lane). Finally, a comprehensive economic analysis allowed us to compare the BEVs with DWPT eRoads, BEVs with fast charging, and ICE trucks from the fleet operator's point of view.

1.3. Main contributions

This study aims to give a comprehensive overview of the technical and economic aspects of a specific ERS technology, the Dynamic Wireless Power Transfer (i.e., electric road through inductive charging) from the fleet operator perspective. Consequently, the study begins by examining the technical aspects, such as assessing the range capabilities of BEVs and trucks equipped with DWPT technology, and it chooses the best technical scenario for a DWPT technology truck for the specific mission adopted. Subsequently, the analysis moves to the economic realm, delving into a comprehensive evaluation of the total cost of ownership throughout the truck's operational life cycle. The results primarily focus on comparing these two technologies, with a conventional ICE truck included as a baseline, representing the current state of the art in freight transport. The main contributions of this article can be summarized as follows:

- **Integration of ERS into TCO analysis:** we devised a methodology to incorporate the costs associated with ERS into a truck's total cost of ownership. Our approach includes a comprehensive cost model specifically tailored to estimate the tariffs of DWPT-ERS, making the investment feasible for a private investor, as well as separate models for estimating the tariffs of private Slow charging spots in the fleet operator depot and public fast charging points.
- **A methodology for time loss cost and energy carrier split between technologies:** to quantify the additional costs incurred by fleet operators when opting for zero-emission trucks over conventional ones due to extended delivery times, we developed a dedicated cost model supported by a powertrain simulation model. Without this simulation model, it is impossible to evaluate the time loss for fleets or accurately assess the real cost of energy carriers split between the three technologies: slow charging stations, fast charging stations, and DWPT. This may explain why these costs have often been omitted in the literature.
- **Including VECTO-like vehicle simulations in the TCO model:** The existing literature often neglects the technical aspects of truck operation in economic assessments. Instead, we devised a comprehensive TCO analysis that exploits results from a detailed vehicle simulation model to evaluate energy consumption and delivery time. This integrated model offers fleet operators a holistic perspective on the costs associated with truck operations. The simulation model itself uses a similar methodology to the VECTO simulation tool developed by the European Union.

2. Material and methods

The goal of the analysis was to assess the total cost of ownership for a group 5 truck (a 4×2 axle configuration with a technically permissible maximum mass exceeding 16 tonnes), considering three powertrain technologies: the conventional ICE truck, the BEV truck, and the BEV equipped with a dynamic charger (DWPT-BEV). Our techno-economical assessment uses a holistic approach that combines a vehicle simulation model, described in Section 2.1, and a total cost of ownership model, described in Section 2.2.

All three truck technologies were subjected to the same operational mission, which requires them to cover 500 km per day. A day of driving was simulated using the vehicle model in 2.1 with five repetitions of the VECTO long haul cycle and including a mandatory 45 min stop, during which the BEV and DWPT-BEV trucks are also allowed to use fast charging. In these simulations, energy consumption and the evolution of the battery state of charge are evaluated; the electric trucks are required to end the day at the depot with at least 50 km of residual range. In order to achieve this target, the BEV truck is allowed to perform additional stops at fast charging stations; whereas the DWPT-BEV is allowed to use the DWPT lane. At the end of the day, the battery is assumed to be fully charged at the depot using slow charging.

Table 1
Main vehicle parameters for the BEV.

Component	Parameter	Value
Vehicle	Curb mass	16.3 tons
	Payload capacity	23.7 tons
	Drag area C_{dA}	5.47 m ²
	Rolling resistance coeff. C_r	0.0055
Final drive	Speed ratio τ_{fd}	2.59
Gearbox	Speed ratios τ_{gb}	{3.86, 1.93}
E-machine	Rated Power	450 kW
	Maximum torque	1080 Nm
Battery	Chemistry	NMC
	Nominal energy	624 kWh
	Nominal capacity	878 Ah
Charger (if present)	Rated Power	200 kW
	Efficiency	80%
	Mass	100 kg

Therefore, the vehicle model returns the energy consumption by energy source as well as the additional time required for the electrified trucks to complete the 500 km mission. These simulation outputs are then used as inputs for the TCO model, as detailed in Section 2.2. The fact that the electric trucks require more time to complete the same daily distance was then compensated in the cost model by assuming that additional trucks are deployed to deliver the same amount of tonne-kilometers annually.

The long-haul mission mentioned previously is an operational profile defined by European Regulation for certification of CO₂ emissions from trucks [20], and also implemented in the Vehicle Energy Consumption Calculation Tool (VECTO). The mission represents a highway scenario with an average speed of over 80 km/h and including also stops and the road slope. Considering that driving approximately 500 km daily in Europe accounts for over 70% of the average distance covered by trucks in a typical fleet [21], we decided to adopt this distance as the daily driving standard for the trucks in our study.

2.1. Simulation model

The truck under study is a 4 × 2 tractor-trailer with a curb mass of 16.3 tons, including the 3.3-ton battery weight. Concerning the current legal limit for the technically permissible maximum laden mass, this yields a payload capacity of 23.7 tons. The key vehicle parameters are detailed in Table 1.

The developed simulation model combines a distance-based backward-facing simulation model with a detailed driver model. This driver model features a tactical layer that predicts upcoming stops, facilitating proactive braking maneuvers. Moreover, it incorporates behavioral acceleration limits and operational acceleration limits, which account for the power and torque limitations of the powertrain components.

The model is capable of effectively handling distance-based operational drive cycles, which are characterized by a time profile of prescribed vehicle speed and road grade as a function of traveled distance. This includes incorporating full stops of predefined duration. Additionally, the model facilitates the simulation of the battery's state-of-charge (SOC) evolution throughout the drive cycle.

In comparison to the simpler and more common time-based approach, this method proves to be more suitable for comparing vehicles with different technologies, especially when they undergo varied operational missions, as highlighted by [22], a necessity evident in the case of the ERS. Moreover, this approach enables the utilization of distance-based Long Haul (LH) driving cycles, as outlined in the EU regulation on CO₂ emissions for conventional trucks. Notably, this LH driving cycle will also serve as the basis for certifying the energy efficiency of BEV trucks in the future. The Joint Research Center of European Commission (JRC) road tests [23] demonstrated that final fuel consumption, obtained with the driving cycle chosen varied by ±3.5% from measurements obtained in a representative real-world

scenario in the experimental phase. Given the measurement variability (σ higher than 2%), this approach was considered suitable for official vehicle certification due to its high representativeness of real-world performance and consistent accuracy across vehicles.

Fig. 1 illustrates the simulation model. The mission defines the desired speed (v_{dex}) and the grade (i.e. the road slope). A driver model attempts to match the actual speed to the desired speed using the acceleration command and, if needed, the brake command. A gear shift logic is also used to set the gear number. The first component of the vehicle model is then the longitudinal dynamics, which gives the required tractive effort F_{veh} as a function of the vehicle speed v_{veh} and road slope s_{veh} , including the rolling resistance F_{roll} , grade force F_{grade} and aerodynamic resistance F_{aero} .

$$F_{veh} = F_{roll} + F_{grade} + F_{aero}, \quad (1)$$

$$F_{roll} = C_r m_{veh} g \cos(s_{veh}), \quad (2)$$

$$F_{grade} = m_{veh} g \sin(s_{veh}), \quad (3)$$

$$F_{aero} = \frac{1}{2} \rho_{air} C_{dA}(v_{veh}) v_{veh}^2 \quad (4)$$

ρ_{air} is the density of air under standard conditions, defined at sea level with an absolute pressure of 101.325 kPa and a temperature of 293 K. Note that the drag area C_{dA} is a function of the vehicle speed as cross-wind correction was also applied.

The e-machine input speed and torque were then evaluated as:

$$\omega_{em} = \frac{v_{veh}}{r_{wh}} \tau_{fd} \tau_{gb}, \quad (5)$$

$$T_{em} = \frac{F_{veh} r_{wh}}{\tau_{fd} \tau_{gb}} \quad (6)$$

ω_{em} is determined by dividing the actual vehicle speed (v_{veh}) by the wheel radius r_{wh} and then multiplying by the final drive ratio τ_{fd} and the gearbox gear ratio τ_{gb} . T_{em} is determined by multiplying the required tractive force per the wheel radius r_{wh} and dividing per the final gear ratio τ_{fd} and the gearbox gear ratio τ_{gb} . Torque loss terms in the final drive and transmission are omitted here for conciseness. The electric power absorbed by the electric motor was evaluated using an electro-mechanical conversion efficiency map η_{em} :

$$P_{em,el} = (\eta_{em}(\omega_{em}, T_{em}))^k \omega_{em} T_{em}, \quad (7)$$

where the e-machine efficiency (η_{em}) is function of the e-machine speed and torque (ω_{em} , T_{em}), with $k = -1$ in motor and $k = 1$ in generator mode; the battery power P_b is then equal to the power drawn by the motor and auxiliaries. Finally, P_b is used as an input to the battery model to evaluate the battery current (i_b) and ultimately the SOC (σ) dynamics:

$$i_b = \frac{v_{oc} + \sqrt{(v_{oc})^2 - 4 \cdot R_{eq} \cdot P_b}}{2 \cdot R_{eq}}, \quad (8)$$

$$\dot{\sigma} = \frac{i_b}{C_b}, \quad (9)$$

where v_{oc} , R_{eq} are the (SOC-dependent) open circuit voltage and internal resistance, and C_b is the battery capacity (in Ah).

To simulate the BEV truck equipped with a DWPT charger, we modified the VECTO long-haul cycle to include the segments traveled on the ERS lane. Fig. 2 shows the simulated vehicle mission. The upper panel shows the reference speed, which the behavioral driver model attempts to follow, and the actual vehicle speed for the BEV truck (blue line) and for the DWPT truck (orange line). Furthermore, the road grade is also shown. It can be seen that, unlike the BEV truck, the DWPT truck has to travel at a reduced speed for the length of the eRoad segment, starting roughly 10 km from the beginning of the mission. The lower panel of Fig. 2 also shows the delivered current for the two electric trucks. From this, the impact of the DWPT lane can be clearly seen, as the current is much lower for the DWPT truck and mostly negative (indicating charging).

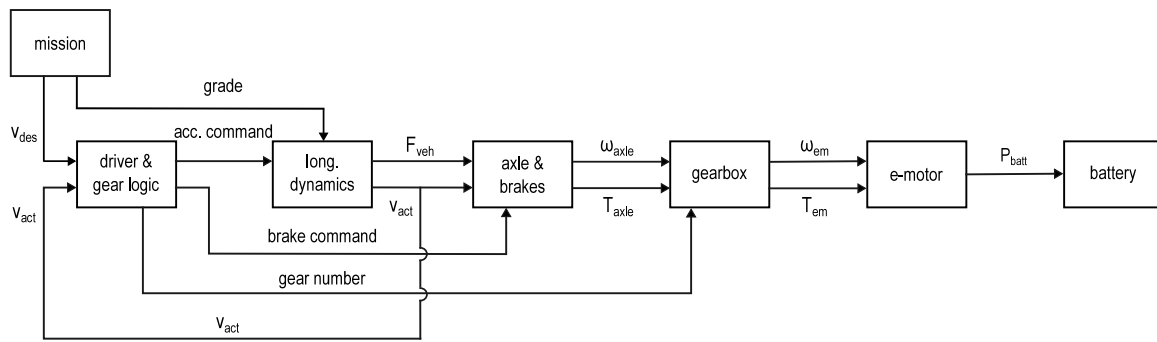

Fig. 1. Simulation model flowchart.

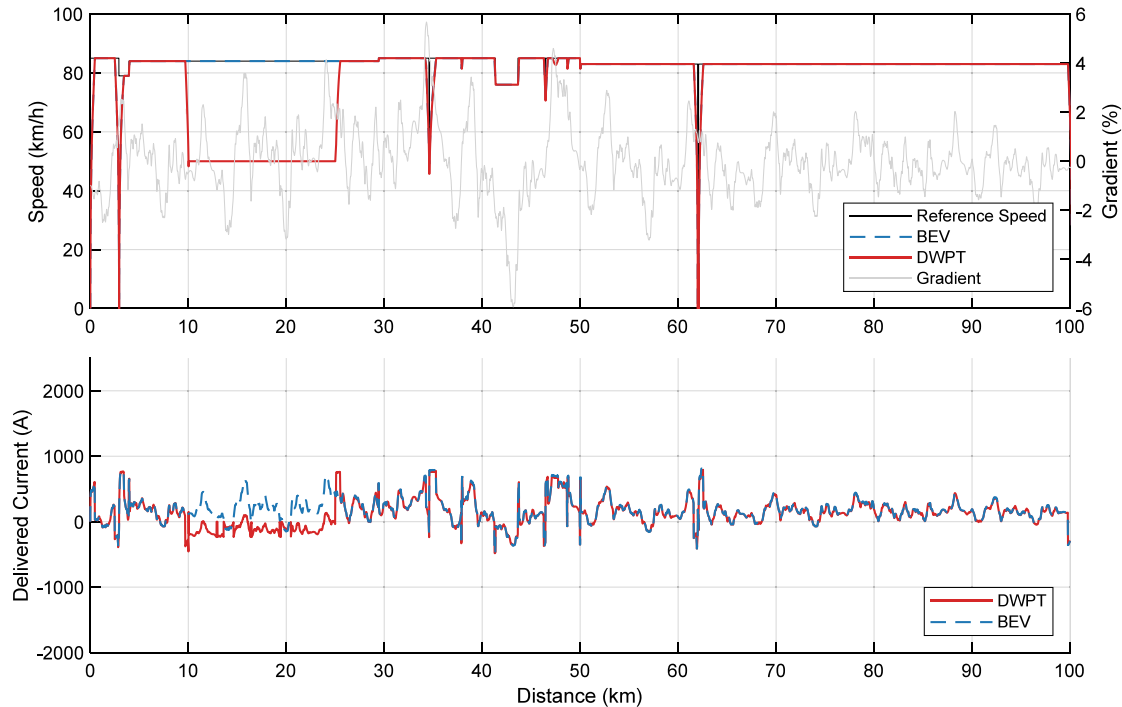

Fig. 2. Operational profiles of the considered delivery mission.

2.2. Truck cost model

Total cost of ownership (TCO), is a holistic approach to assess the complete financial impact of owning and operating an asset over its entire lifecycle [24]. This includes not just the initial purchase price but also the ongoing expenses related to maintenance, operation, and any potential costs [25,26]. One key aspect of TCO is its emphasis on the entire asset lifecycle. This perspective forces businesses to move beyond the upfront cost and to factor in expenses that arise throughout their useful life, such as maintenance, upgrades, and potential end-of-life costs. TCO analysis begins with the purchase price, encompassing not only the initial acquisition cost but also associated expenses like taxes, shipping, and installation fees. For the trucks being studied, the purchase cost refers to the initial expense incurred by a fleet operator in acquiring the vehicle. Operating costs make up a significant portion of TCO. They include expenses related to energy consumption (e.g., fuel for conventional vehicles), preventive maintenance and repairs, and any consumables required for the asset's proper functioning (e.g., urea, lubricating oil, etc.). Lastly, the residual value refers to the asset's worth after the ownership period. The TCO model was designed to analyze the BEV, DWPT, and conventional ICE vehicles. The lifespan taken into account for the evaluated trucks is the entire vehicle life cycle, defined

in this study as the minimum life requirement for the vehicle class according to the Euro 7 draft [27] (i.e., 700,000 km driven for this specific vehicle category). The TCO model focuses on fixed and variable costs that a fleet operator encounters throughout the entire life cycle. These include:

- the purchase cost;
- all of the taxes related to the ownership and operation;
- the specific driver cost;
- the maintenance and repair cost;
- the time penalty cost;
- the energy carrier cost;
- the depreciation.

Note that the time penalty cost and energy carrier cost are evaluated thanks to the outputs of the simulation model, i.e. the delivery time and energy consumption.

The payload loss cost was not considered in this study as we decided to run our simulations with the representative payload described in the EU regulation. For this specific truck group, the representative payload is around 60% of the payload capacity for the ICE truck. With this payload, the battery mass in the BEV truck is not enough to induce a payload loss. In any way, the payload loss cost can be modeled similarly to the time penalty cost described later.

Table 2
TCO model assumptions.

Parameters	Assumptions
Analysis period	700 000 km driven
Discount rate	10%
Inflation	Average inflation over the last twenty years in Europe
Taxes	All taxes linked to the truck ownership and operation
Road tolls	Included
External costs	Excluded

The main output of the analysis is the TCO calculated as the net present value (*NPV*) of all costs incurred. The net present value is a financial metric that considers the time value of money. Its value reflects the present value of expected cash flows CF_t , both inflows and outflows, by discounting them at a discount rate r :

$$NPV = \sum_{t=0}^n \frac{CF_t}{(1+r)^t}. \quad (10)$$

The analysis includes all the taxes linked to the ownership and the operation of the truck, it is used a discount rate of 10% to assess the NPV of the operation cost that occurred year by year during the period under analysis. The main parameters are shown and summarized in Table 2. It is important to note that external costs, including those attributed to pollutant emissions and fatalities, were intentionally omitted from the TCO model developed. This omission was a result of aligning the study scope with a focused examination of direct costs associated with ownership and operation.

The energy consumption of the ICE truck, as well as the BEV and DWPT, was obtained with the energy consumption results of the simulation model and reported in Section 3. This input comes directly from the simulation model and will impact the energy carrier cost. Therefore, no assumptions based on published literature data are made regarding energy consumption during the truck's daily operation or its energy use while driving through the ERS lane. The model incorporates various types of costs categorized as both fixed and variable. The TCO model's fixed costs are those that are not dependent on the distance traveled by the truck analyzed. These costs encompass the purchase price of the vehicle, focusing on acquisition costs while excluding considerations of loan interests. Additionally, they encompass registration and ownership taxes and insurance expenses. Instead, variable costs are costs that depend on the distance traveled by the vehicle. These include driver cost, maintenance cost, highway toll, and energy carrier cost. The driver cost is the cost of hiring a driver to operate the vehicle, including the driver's salary, benefits, and other expenses related to the driver's employment. Maintenance costs are the cost of maintaining the vehicle, including the cost of parts, labor, and other related expenses. The energy carrier cost is the cost of the fuel or energy used to power the vehicle. This cost includes the cost of the fuel or energy itself, as well as any other taxes and expenses related to the use of the fuel or energy.

2.2.1. Purchase cost

The purchase cost of a group 5 conventional VECTO truck equipped with an internal combustion engine rated at 450 kW in a 4×2 configuration was assumed to be 120,000 EURO for the tractor-trailer and 50,000 EURO for the trailer. Therefore, the purchase cost of a conventional tractor-trailer was assumed to be 170,000 EURO in 2022; this figure is consistent with estimates that can be found in the literature [19,28]. Finally, it should be noted that these costs are exclusive of value-added tax (VAT) since fleet operators can typically recover this type of tax.

Regarding the preliminary assessment of the two new truck technologies, no reliable figures exist because there is no mass production of these vehicles yet. Therefore, we developed an estimate with the following procedure:

- identify the configuration of the correspondent conventional truck;
- remove subsystems not included in the zero emissions truck (e.g., conventional powertrain, conventional driveline, aftertreatment subsystem);
- integrate necessary subsystems for a zero-emissions truck, using specific prices sourced from literature. Furthermore, integration factors were applied to scale individual component costs to the vehicle integration process.

2.2.2. Taxes

The transport taxes, specifically the registration and ownership taxes, were obtained from a European Commission report [29]. The data regarding insurance, originally sourced from the report published by Comité National Routier [30], has been adjusted to reflect inflation in the insurance sector. Data on registration tax and ownership tax collected from various European countries were combined to create an average scenario reflecting conditions across Europe. In this scenario, the registration tax was set at 379 EURO. Additionally, for an average European scenario, the ownership tax was assumed to be 993.5 EURO/year. Insurance expenses amount to 3000 EURO annually. Lastly, highway tolls were considered to be 0.152 EURO/km driven on the highway, extrapolated from [19]. Ownership tax, insurance, and highway tolls were adjusted using the NPV formula because they represent annual expenses. However, it was not required to adjust the registration tax, as it is a one-time payment tax.

2.2.3. Driver cost

The TCO model includes the driver costs across European countries, breaking them down into three main components: average salary, travel allowances, and employer's social contributions. Each specific cost parameter is thoroughly documented on a country-specific basis, drawing from the latest reports on the employment and compensation conditions of international lorry drivers in Europe. These reports, published by the Comité National Routier [30–37] within the past three years, serve as the primary source of data. The analysis shows a wide variability in drivers' hourly driver costs among the selected countries. France emerges as the country with the highest hourly cost for drivers, at 36.01 EURO/h. In sharp contrast, Poland exhibits the lowest driver cost per hour, standing at 11.19 EURO/h. In this study, after data collection, it was decided to consider an average European scenario with the average driver cost divided into average salary, with an amount of 28,309 EURO/year, a part due to travel allowances of 11,027 EURO/year, and the last part related to employee social contribution of 9072 EURO/year. The sum of these three cost components gives the total cost of hiring a driver, which is 48,409 EURO/year. If we consider the average annual number of driving hours (equal to 1847 hours/year), the hourly cost of the driver is 26.59 EURO/hour.

2.2.4. Maintenance cost

The maintenance cost has been modeled based on secondary data provided by [19], which has been grouped into four categories: lubricant oil, AdBlue refilling, repair and preventive maintenance, and tires. The preliminary estimation of the maintenance costs related to the two new technologies truck is also based on data from ICCT reports [19], which show that battery electric trucks can obtain a reduction compared to diesel-powered trucks. Since the DWPT truck is a BEV, we adopted the same maintenance cost as the BEV. This is because there is no need to refill AdBlue and lubricants oils as also described in conference paper [38] and several reports [19,28] have reported that the repair and maintenance of BEV and DWPT can be 30% lower than the counterpart.

2.2.5. Energy carrier cost

The cost of the energy carrier can be highly sensitive to slight variations in prices and is thus a critical aspect of the vehicle life

cycle for the fleet operator. Therefore, several scenarios were analyzed. To ensure accuracy for the baseline scenario (i.e., ICE), we relied on the weekly oil bulletin published by the European Commission [39]. This bulletin includes updated week-by-week, country-by-country data for automotive diesel fuel, including all taxes. In addition, in our model, partial reimbursement of excise taxes in countries where such reimbursement is applicable, and VAT recovery has also been taken into account. As with the previous cost types, we have assumed an average cost in Europe relative to 2022.

The cost related to battery charging is a topic that has many uncertainties. Given the high uncertainty related to this, we created three parametric cost models: one for the low-power charging station carried out in the fleet operator's depot with a charging power of up to 100 kW, one for the public fast charging station with a maximum power of 350 kW, and the last for the toll due to charging due to DWPT. Data on the cost of electricity are taken from EUROSTAT [40]. Specifically, electricity prices for non-domestic consumers falling in the consumption range of 500 MWh to 1999 MWh are used. The cost models are dependent on electricity cost, infrastructure capital expenditure (CAPEX), and utilization ratio (UT).

Both BEV and DWPT recharge their battery pack both in slow charging stations at the fleet operator's depot and in public fast charging stations. In addition, DWPT has a third way of recharging which is recharging while driving, that is the opportunity given by the ERS technology. The cost model logic remains consistent across all three technologies. First, the net cash flow required to secure a viable investment for the investor was evaluated: for Slow charging station infrastructure, this investor is the fleet operator; for fast charging stations and DWPT lanes, it is the infrastructure owner. Subsequently, the annual electricity consumption resulting from the utilization of the particular infrastructure is assessed. This was followed by calculating the minimum revenue essential for the investor to sustain the investment. Finally, toll calculation was conducted. The workflow of these cost models is given by Eqs. (11) to (15).

The equation represented by (11) defines the net cash flow CF_n required to achieve a targeted internal rate of return (IRR) for a specific investment. Through this equation, we calculate the minimum cash flow needed during the investment period, considering the initial capital expenditure (CAPEX) and the discounting effect over time (t) based on the IRR.

$$CF_n = \frac{\text{CAPEX}}{\sum_{t=1}^T \frac{1}{(1+\text{IRR})^t}} \quad (11)$$

The annual energy consumption E_y of recharging infrastructure is computed through Eq. (12). It is dependent on various factors such as power (P), utilization ratio (UT), working days in a year (W_y), average daily working hours (h_d), and efficiency (η).

In this study, the utilization ratio is a key metric used to describe the employment efficiency of the recharging infrastructure. It is defined, in accordance to [19], as the ratio between the annual energy output sold by the infrastructure owner and the infrastructure's maximum capacity. Essentially, the utilization ratio reflects the number of trucks recharged annually per charger or ERS lane.

Given the significant impact of the utilization ratio on the cost of the energy carriers, we have assumed three different values to represent three distinct utilization scenarios, as outlined in Table 3, which details the primary parameters chosen for the technologies under consideration.

$$E_y = \frac{P \times (UT \times W_y \times d_W \times h_d)}{\eta} \quad (12)$$

Furthermore, the model determines the annual energy sold (ES_y), representing the energy effectively sold by the infrastructure operator to users, considering the energy losses.

$$ES_y = P \times (UT \times W_y \times d_W \times h_d) \quad (13)$$

Table 3

Main parameters used for the cost model of recharging technologies.

Recharging technology	Slow charging station	Fast charging station	DWPT lane
Average European electricity cost (EURO/kWh)	0.25	0.25	0.25
Utilization ratio (%)	33, 20, 10	12, 5, 1	12, 5, 1
Annual weeks	52	52	52
N° operation per week	6	6	6
Charging power (kW)	100	350	200
Charging efficiency (%)	95	95	80
Internal rate of return (%)	10	10	10
Service life (y)	15	10	20
Tariff (EURO/kWh)	0.29, 0.32, 0.39	0.36, 0.52, 1.61	0.38, 1.70, 3

Through Eq. (14) we assessed the minimum revenue (R) that an infrastructure operator must generate to cover costs and achieve the expected profitability. It incorporates the previously calculated net cash flow (CF_n), the annual energy consumption cost (E_y) multiplied by operating expenses per kilowatt-hour ($OPEX_{kWh}$), and the annual maintenance cost (M).

$$R = CF_n + E_y \times OPEX_{kWh} + M \quad (14)$$

Finally, Eq. (15) computes the estimated tariff, representing the price charged per unit of energy consumed by users. It is calculated by dividing the minimum revenue R and the annual energy sold ES_y .

$$\text{Tariff} = \frac{R}{ES_y} \quad (15)$$

The cost models employed in this study estimate the tariff associated with various recharging technologies. A critical parameter in these models is the infrastructure CAPEX. For slow charging stations and public fast charging stations, the CAPEX data was sourced from [19] and adjusted for 2022 using the construction inflation index recorded in the previous eighteen years. Regarding the construction of DWPT lanes, data was gathered from two sources [12,14], which represent different scenarios for implementing DWPT lane infrastructure. Table 3 presents the primary parameters of the three technologies under consideration.

For the DWPT lane and in the pessimistic scenario only, we did not use the same internal rate of return (10%) as for all other cases, as this would lead to a toll of approximately 10 EURO/kWh, which is not competitive. Instead, we capped the toll at 3 EURO/kWh, assuming that the operator would be willing to accept a lower IRR to achieve higher market penetration. As the results in Section 3 show, this assumption is still not enough to make the DWPT a cost-competitive technology under the pessimistic scenario. The only scenario where DWPT is competitive is the optimistic scenario, where a utilization ratio of 12% was assumed.

2.2.6. Time penalty cost

The need for additional stops required to charge the BEV trucks during a delivery translates into increased costs for fleet operators. Thanks to the strong connection between the developed simulation model and our cost models, we were able to accurately assess the increase in delivery time, based on a daily mileage of approximately 500 km (as assumed in 2) and the energy consumption for the specific payload. In our simulations, the BEV truck was allowed to stop at fast charging stations to charge the required amount to complete the delivery. The DWPT-BEV can use both the fast-charging stations and the DWPT lanes. The extended delivery time for electric trucks directly affects the number of trips a truck can complete within a year, resulting

Table 4
Residual value coefficients used for the residual value.

Adopted coefficients	Value
$\exp(A_v)$	0.922
$\exp(A_b)$	0.968
$\exp(M)$	0.922

in a reduction in potential revenue. To mitigate this revenue loss, the operator must invest in a portion of new BEV or DWPT-BEV trucks and hire a corresponding fraction of drivers to ensure the same volume of goods is transported annually (the same tonne-kilometers).

Through Eq. (16) we assessed the annual added time AT_y by multiplying the difference in delivery times ($t_{ZEV} - t_{ICE}$) by the number of working days in a year J , t_{ZEV} represents the delivery time for a zero-emission vehicle, while t_{ICE} represents the delivery time for a conventional vehicle, measured in hours.

$$AT_y = J \times (t_{ZEV} - t_{ICE}) \quad (16)$$

Moreover, with Eq. (17), we computed the fraction of journeys lost JL of a BEV or DWPT compared to an ICE truck. It divides the annual added time AT_y by the annual driving time AD_y .

$$JL = \frac{AT_y}{AD_y} \quad (17)$$

Eq. (18) represents the time penalty cost L , which accounts for acquiring a portion of a BEV or DWPT to compensate for reduced capability and hiring a corresponding fraction of drivers. C_{ZEV} denotes the purchase cost of a zero-emission vehicle, and DC represents the driver cost. Therefore, the fraction of journeys lost (JL) multiplied by the driver cost (DC) is the cash flow CF_t to which the NPV formula (10) is applied to account for cash flow during the ownership period.

$$L = JL \times C_{ZEV} + \sum_{t=0}^n \frac{CF_t}{(1+r)^t} \quad (18)$$

2.2.7. Residual value

Determining the residual value of a truck is a complex task, as it depends not only on the vehicle's age but also on the mileage it has covered. The proposed approach, adapted from [41], describes the depreciation of the truck with an exponential function of mileage and age. This method aims to establish a comprehensive understanding of the residual value by incorporating factors such as age and mileage, contributing to a more accurate and nuanced assessment of the truck's long-term value.

$$RV_{ICE} = C \cdot \exp(A \cdot a + M \cdot m) \quad (19)$$

Where: $RV(a, m)$ represents the truck residual value, C is the truck purchase cost a is the age in years, m is the mileage in thousands of kilometers, $\exp(A)$ is the price reduction related to the year, and $\exp(M)$ is the price reduction related to the mileage.

The residual value of an electric vehicle is not only dependent on the general wear of its components but also on the residual capacity of its battery pack. Furthermore, the battery holds a large share of the vehicle's value, and it can be replaced. Therefore, it was deemed more appropriate to disjoin the value of the vehicle and the value of the battery pack. This was modeled with two price reduction coefficients A_v and A_b . Based on available literature [42], the residual value of the battery pack was considered equal to 85% after 5 years. The coefficients adopted are reported in Table 4.

$$RV_{ZEV} = (C_v - C_b) \cdot \exp(A_v \cdot a + M \cdot m) + C_b \cdot \exp(A_b \cdot a + M \cdot m) \quad (20)$$

2.2.8. Future projections

In the cost model, there are some projections related to the energy price and the purchase cost of the BEV and DWPT-BEV subsystems (e.g., battery, e-motor). About the energy price projection, the trend has been taken from the Green Book of the Department for Energy Security and Net Zero of the United Kingdom (UK) government [43]. About the reduction of the purchase cost of the battery, the scenario included in our study is that considered in the international council on clean transportation (ICCT) report [19]. Therefore, we assessed for 2022, 2030, and 2050. Furthermore, since the energy carrier cost is a highly sensible parameter that changes the results significantly, we did three scenarios: an optimistic scenario, an average scenario, and a pessimistic scenario for today's results but also for future results.

2.3. Assumptions on the charging strategies

The energy consumption by source, as well as delivery times, depend on the assumptions we made about refueling and recharging. For the ICE truck, we assume that only one 45-minute stop is performed, which was necessary to conform to mandatory EU rest periods. We assume that refueling can happen either at the depot or during these stops, thus not requiring any additional time.

On the other hand, the BEV requires additional time to charge the battery. First and foremost, we assumed that at the end of a delivery mission, the operator would fully charge the battery at the depot using slow charging, as this is the most convenient option. However, our vehicle simulation model predicts that it is not feasible to complete a full delivery mission with a full charge. Thus, we assume that the operator would use fast charging as needed to complete the mission and return to the depot with a reasonable safety margin, which we set as the energy equivalent of 50 km of residual range.

Given the energy consumption obtained from the simulation, it was determined that two stops at fast charging stations were required to fulfill the BEV's daily mission. Specifically, the driver needs to stop twice, charging the battery for 35 min each time. It was also assumed that at each stop, 5 min are required for parking, activating the charging station, paying, and resuming the journey. Additionally, it was assumed that the fast charging station operates at 95% efficiency and provides an average power of 350 kW. Therefore, each stop lasts 40 min and charges 194 kWh, which roughly corresponds to an additional 134 km on the long haul cycle. To manage the journey effectively, the driver divides the daily trip into three equal parts, driving approximately 167 km per sub-trip before stopping to recharge the battery. With the two planned stops, the driver can cover a total distance of 500 km to reach the daily driving mission target, with a residual range of approximately 50 km.

For the DWPT truck, we assumed that the operator would fully charge the truck using slow charging at the depot, then use fast charging for 40 min during the mandatory rest period, and use dynamic charging to charge the remaining energy required to return to the depot with 50 km of residual range. This strategy was selected as a result of an analysis of different deployment and utilization scenarios for the DWPT lane. We constructed these scenarios by adjusting the charger power rating, DWPT lane length, and travel speed within the DWPT lane. Specifically, we investigated speeds ranging from 50 km/h to 70 km/h, charging power from 80 kW to 200 kW, and DWPT lane lengths from 5 to 20 km per every 100 km of highway. The selection of speeds from 50 km/h to 70 km/h was based on real-life tests conducted during the validation phase of the [13]. In these tests, power efficiency exceeding 80% was achieved at speeds of 10 km/h, 30 km/h, and 50 km/h. Additionally, the analysis from these tests indicated that the impact of speed was negligible within the explored range (up to 70 km/h) under favorable alignment conditions. This methodology aligns with previous work where payload influence was also considered [44]. In this study, we maintained a fixed payload, referred to as the representative payload, across all scenarios.

Table 5
Average energy consumption predicted by the vehicle simulation model.

	ICE	BEV	DWPT-BEV
Energy consumption (kWh/km)	2.31	1.45	1.46

Table 6
Recharging ratio by technology.

Truck technology	Slow charging	Fast charging	DWPT
BEV	46%	54%	–
DWPT	46%	30%	24%

3. Results and discussion

3.1. Energy usage

Energy consumption is one of the most important factors in the total cost of ownership. Table 5 reports the energy consumption of the three truck technologies obtained with the vehicle simulation model. The ICE truck consumes more energy because of its conversion efficiency.

Notably, the BEV and DWPT trucks exhibit nearly identical energy consumption, differing by only 100 kg attributable to the wireless charger and both utilizing the same driveline, hence yielding similar results. However, it is important to note that the energy consumption of the DWPT truck, as listed in Table 5, encompasses the combined energy from two sources: its primary onboard energy source, namely the battery pack, and the energy supplied by the DWPT lane. The latter is provided when the truck recharges while driving through the specific section, as outlined in Fig. 2, where the red line indicates the DWPT speed and highlights the speed reduction during these recharge-while-driving segments.

As a result, each scenario presents a trade-off in terms of the charged energy and the additional travel time (due to the reduced speed required while driving on the DWPT lane).

Our primary goal was to ensure that the electric truck only needed to stop once during its daily journey. To accomplish this, we conducted simulations for a daily mission spanning 500 km, assuming there would be 50 km of range left at the end of the day. We varied both the dynamic charging power and the length of the DWPT lane.

Furthermore, our secondary objective was to minimize the additional delivery time as much as possible. Thus, we opted for the highest speed value within the chosen range to save time.

Our analysis unveiled three viable options: one featured a DWPT lane length equivalent to 15% of the daily mission (e.g., 15 km for every 100 km) paired with a dynamic charger rated at 200 kW. The other two options entailed a DWPT lane length of 20% of the mission, with dynamic chargers rated at 160 kW and 200 kW, respectively. We ultimately chose the 15 km DWPT lane solution because it requires the lowest investment for DWPT lane investors and incurs the least additional delivery time.

The resulting range for this specific scenario is 362 km. During the mandatory 45-minute stop, the driver recharges the truck at the fast charging station to complete the daily mission.

With the selected scenario, the daily additional delivery time of a DWPT truck is lower than that of a BEV, amounting to only 10 min per day compared to an ICEV, or 25 min less compared to the BEV. Finally, the electricity use by source, which has a strong impact on the energy carrier cost, is reported in Table 6.

3.2. Total cost of ownership

Given the potential for significant variability in energy carrier costs and truck purchase prices, particularly since BEV and DWPT vehicles are not yet produced on a mass scale, we addressed this sensitivity by examining three distinct economic scenarios: a pessimistic, an average,

and an optimistic scenario. Additionally, we assessed these scenarios with respect to 2022, 2030, and 2050; the last two consider anticipated reductions in electricity prices and decreases in the purchase cost of alternative trucks due to economies of scale.

In the optimistic economic scenario, we evaluated low electricity prices by assuming a high utilization ratio for all charging infrastructure as part of the cost model discussed in Section 2.2.5. Conversely, in a pessimistic economic scenario, we considered low utilization rates, which result in higher end-user electricity costs for all charging technologies. Finally, the third scenario falls between the optimistic and pessimistic scenarios, reflecting an average expectation.

The primary findings, as outlined in Fig. 3, suggest that, based on the economic assumptions incorporated into the model, ICE technology continues to be the most economically feasible choice for long-haul goods transportation, except under the optimistic economic scenario projected for 2030 and beyond. The primary obstacles to achieving cost parity with ICE trucks over the full life cycle are the costs associated with energy carriers and truck purchases. Achieving cost parity with current CAPEX is contingent upon achieving high utilization of the recharging infrastructures. Therefore, the role of recharge infrastructures, and the subsequent recharging costs, are crucial from an economic standpoint. Another significant finding is that the developed time penalty cost model appears to have a negligible impact on the truck's full cycle but it is the cost type that aids the DWPT truck in achieving cost parity with the BEV truck in this optimistic scenario.

3.2.1. Purchase cost

Upon analyzing the results depicted in Fig. 3, it becomes apparent that even in the most optimistic scenario, the ICE truck remains the most cost-effective option among the three technologies under consideration. This is primarily because the purchase price of alternative trucks, such as BEV and DWPT trucks, is more than double that of ICE trucks, as illustrated in Fig. 4. Specifically, we observe that the battery pack and its integration into the truck constitute approximately 50% of the purchase cost of the BEV/DWPT truck, indicating its significant impact as the most substantial subsystem. Conversely, there is a cost reduction in the truck propulsion system of the BEV/DWPT truck compared to the ICE. Notably, the combined cost of the three propulsion subsystems (Powertrain, conventional driveline, and aftertreatment) exceeds that of the electric driveline alone, which encompasses all propulsion systems of the BEV/DWPT truck. This emphasizes the critical importance of battery mass production in reducing battery costs, as well as the significance of mass-producing BEV trucks to reduce costs associated with vehicle integration processes. The trailer subsystem, which accounts for approximately 30% of the purchase cost in the ICE truck, remains consistent across all technologies, thus rendering its influence negligible in the technology comparison. Finally, the purchase cost of the BEV and DWPT trucks are very close, with the only difference being the DWPT charger cost which amounts to 5000 EURO.

3.2.2. Energy carrier cost

One of the main results of our assessment is that the energy carrier cost will be crucial for achieving TCO parity between ICE and electric trucks.

The spot price of electricity has experienced a notable increase in recent years. Consequently, even in an optimistic scenario where recharging infrastructures are extensively utilized, the end-user cost of electricity remains high. By 2030, in the optimistic scenario, achieving TCO parity could be within reach provided there are significant reductions in the costs of critical subsystems but also with a sensible reduction in electricity cost. For instance, the projection scenario entails a 33% reduction in battery pack costs, a 28% reduction in electric driveline costs—encompassing components like the e-motor and power electronics—and a reduction of approximately 37% in the raw material price of electricity. These are necessary milestones to consider for TCO

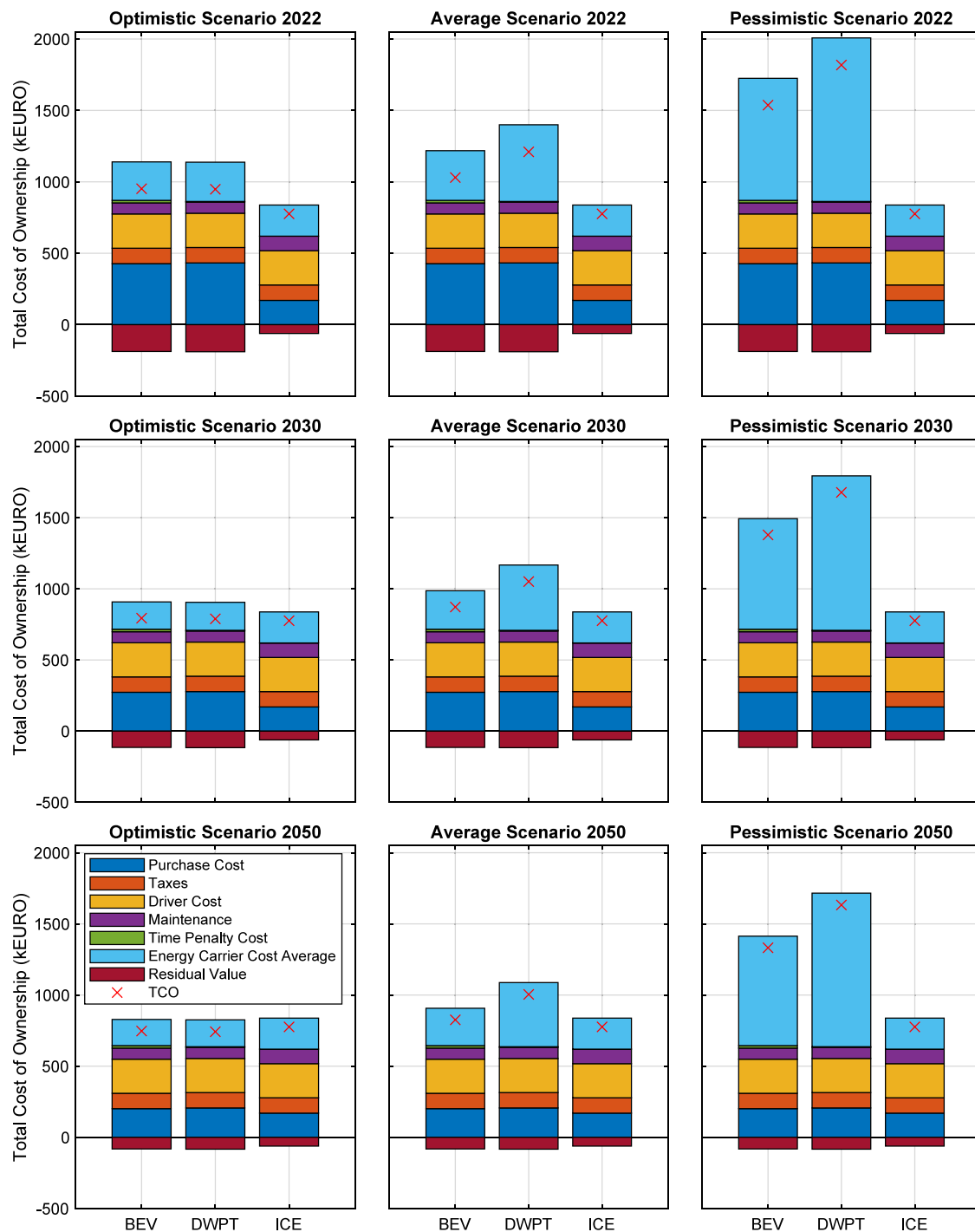

Fig. 3. Total cost of ownership of the three technologies considering different energy price scenarios and starting year.

parity by 2030. Achieving TCO parity becomes even more feasible under the average scenario by 2050. In every future scenario, the utilization of infrastructures will play a pivotal role in keeping the tariff as low as possible.

The utilization ratio of the charging infrastructure is also crucial in ensuring the economic viability of dynamic charging. Under the average and pessimistic scenarios, the cost of charging through DWPT is simply too high compared to fast charging stations to be competitive. Only in the optimistic scenario, with a relatively high utilization ratio, is DWPT a competitive technology. In fact, as depicted in Fig. 5, the breakdown of energy carrier costs reveals significant differences

between BEVs and DWPT trucks. In the average energy carrier cost scenario, the BEV truck averages approximately 0.41 EURO per kWh, whereas the DWPT truck incurs a higher cost exceeding 0.6 EURO per kWh. This discrepancy arises primarily due to the substantial investment required for establishing electrified corridors necessary for dynamic charging. Only in the optimistic scenario do the total energy carrier costs per kWh for both technologies converge nearly equally. Conversely, in the pessimistic scenario, costs increase sharply, with BEVs reaching approximately 1 EURO per kWh and DWPT nearing 1.4 EURO per kWh. These cost breakdowns were derived from a simulation model meticulously designed to accurately capture recharging

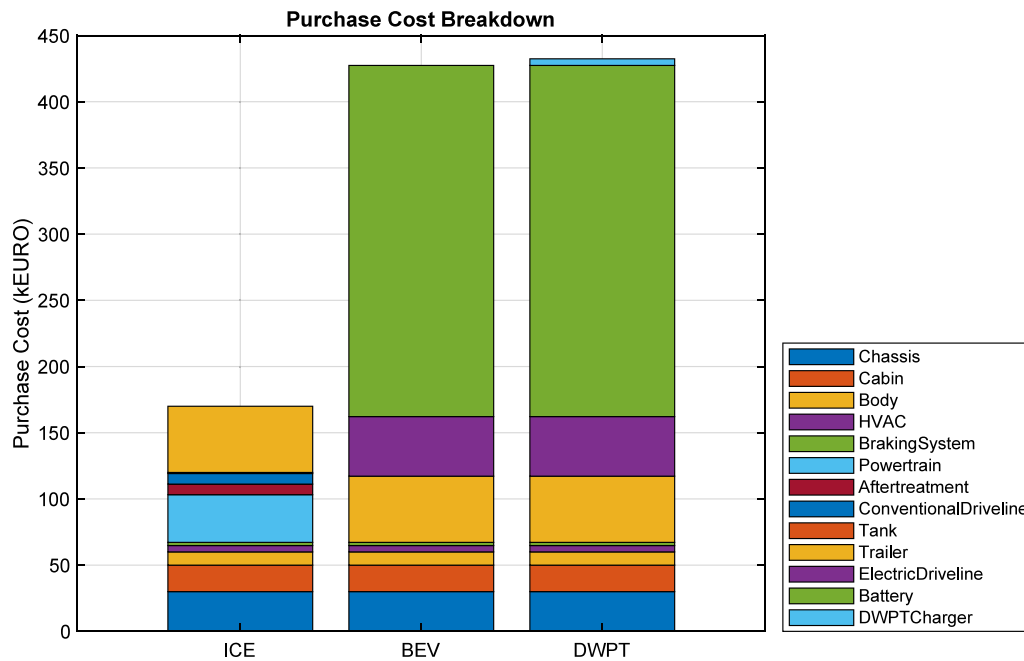

Fig. 4. Purchase cost breakdown, 2022.

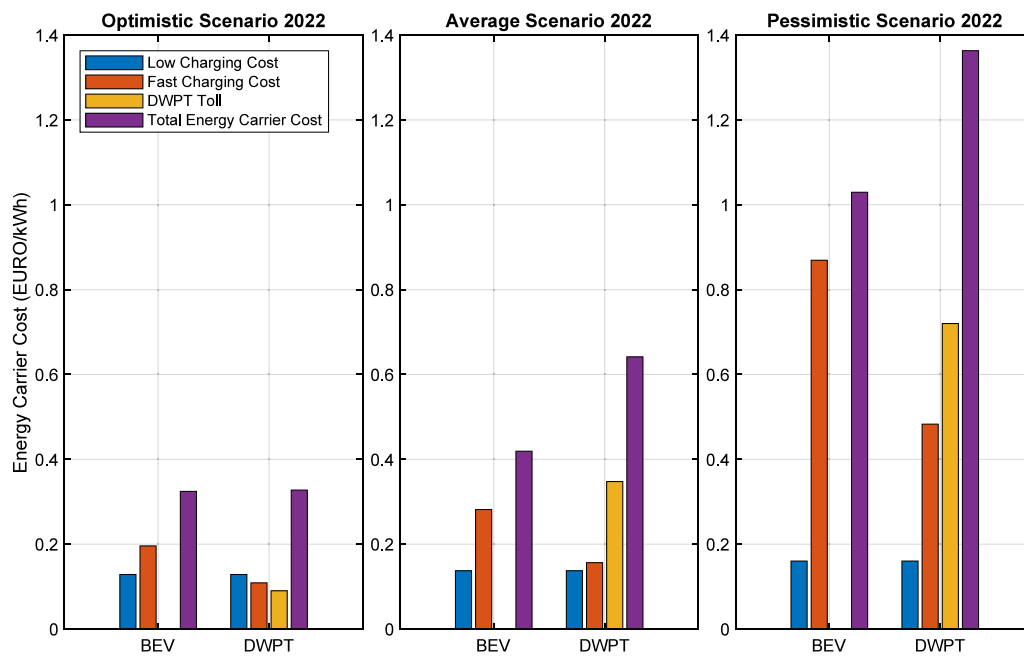

Fig. 5. Energy carrier cost breakdown.

demands throughout the daily operational cycle. This underscores the critical role of infrastructure utilization in achieving cost-effectiveness for electrified powertrains.

3.2.3. Time penalty cost

Another notable result of our work is the relatively small impact of the time penalty cost resulting from the increased delivery time for the specific daily mission considered (500 km). As depicted in Fig. 3, this cost is almost negligible, constituting approximately 2% of the overall cost over the truck lifecycle. This finding challenges the common belief that BEVs may not be feasible for long-haul applications due to extended delivery times.

The DWPT showcases even lower time penalty costs, boasting reductions of up to 70%. Therefore, from the fleet operator's standpoint, the ERS technology can significantly enhance daily performance compared to the BEV technology by minimizing time spent on battery recharging, ultimately leading to improved efficiency in delivering goods. However, the marginal cost remains negligible in absolute terms, particularly when accounting for the additional expense of installing the dynamic charger. Nonetheless, the reduction in time penalty cost for the DWPT enables TCO parity between the two BEV and DWPT in the optimistic scenario, as this reduction more than compensates the increase in energy carrier cost.

Finally, it should be noted that this cost is dependent, among others, on two assumptions:

- The considered daily mission length of 500 km. This distance was selected because it is considered as a representative condition for most fleets, as reported by [21]. Longer distances might increase the time penalty cost for the BEV.
- The assumption that longer delivery times can be compensated by deploying additional trucks, which was used to quantify the time penalty cost. In practice, this may not always be feasible in cases where customers require strict time constraints; in these cases, an additional penalty should be considered for the BEV truck.

If these assumptions do not hold, the time penalty cost for the BEV truck would increase, thus making the DWPT truck more competitive in comparison.

3.2.4. Maintenance

As anticipated, the maintenance costs for the BEV and DWPT trucks are almost 35% lower compared to the ICE truck. This is due to the absence of AdBlue refilling and lubricating oil needs, and also because BEV/DWPT trucks have fewer components in their powertrain subsystems, thus reducing the likelihood of failures. However, since maintenance costs have a relatively low impact over the full life cycle, as depicted in Fig. 3, the significant reduction in maintenance expenses for the BEV/DWPT trucks alone cannot achieve TCO parity with the baseline.

3.2.5. Sensitivity analysis

Given the significant uncertainties surrounding recharging technologies and their associated energy carrier costs, we conducted a sensitivity analysis to explore how these costs might vary by altering one key parameter at a time. First, we adjusted the utilization ratio while keeping all other parameters fixed, as in the average scenario. Next, we examined the impact of electricity costs by comparing the European average used in the main evaluation with electricity prices from two European countries with the lowest (Kosovo at 0.07 EUR/kWh) and highest (Romania at 0.43 EUR/kWh) rates. This allowed us to highlight potential variations due to country-specific factors and differences in raw electricity costs. Finally, we varied the initial investment required by the infrastructure owner to build the recharging infrastructure, emphasizing the possible fluctuations in final costs arising from uncertainties in capital expenditure. For public fast-charging and private slow-charging technologies, we assumed a $\pm 20\%$ variation in capital expenditure. In contrast, for DWPT technology, we considered a range of cost estimates based on the comprehensive review published in [45], evaluating both the lowest and highest cost scenarios for the infrastructure owner.

The results, presented in Fig. 6, reveal several key insights:

- Panel (a) illustrates the relative deviation in energy carrier costs for DWPT technology when varying the three crucial considered parameters. The most significant variation occurs with changes in the utilization ratio. When the utilization ratio decreases from the average value of 5% to a worst-case scenario of 1%, the energy carrier cost increases by more than 330% compared to the average price of 1.71 EUR/kWh. Conversely, with a higher utilization ratio of 12% (1440 trucks that have been recharged daily while driving. This high utilization scenario was taken from [13]), the price drops by approximately 50%. The utilization ratio is the most critical parameter for DWPT technology because, under our cost model, the infrastructure owner must distribute the CAPEX across the number of customers. Therefore, lower utilization leads to significantly higher costs per kilowatt-hour. On the other hand, electricity cost is the least influential parameter for DWPT because the large initial investment means that OPEX has a relatively minor impact on the final customer price. Finally, varying the CAPEX shows that the energy carrier cost could increase by over 50% if we move from the average cost estimate to a higher cost scenario, or decrease by up to 60% under the lower cost scenario.

- Panel (b) shows the sensitivity analysis for public fast-charging technology across the three parameters. Similar to DWPT, the utilization ratio, assumed to be 5% on average (ranging from 1%, or 112 trucks annually, to 12%, or 1348 trucks annually), emerges as the most significant factor, particularly when the infrastructure serves only a small number of users. These truck counts align with figures reported in the literature on infrastructure utilization [46, 47], which cap maximum utilization to avoid potential congestion at 5 h per day. Given the working day assumption in our study, this corresponds to 1667 trucks recharged annually, ensuring our utilization ratio is consistent with published data. In this scenario, the cost of electricity becomes more critical, as OPEX forms a larger share of the total costs, while CAPEX, which is substantially lower than in DWPT, plays a smaller role. Finally, a $\pm 20\%$ change in CAPEX results in a relatively minor effect on the recharging price, confirming that CAPEX is the least influential parameter in terms of price variability.
- Panel (c) presents the sensitivity analysis for private slow-charging technology. In this case, electricity cost becomes a prominent factor because OPEX constitutes the majority of the total cost, given that CAPEX is relatively low compared to the other two technologies. Additionally, variations in CAPEX have a minimal impact on the final price. The utilization ratio also has a limited effect on the final cost for the fleet operator, as utilization in a private charging station remains relatively high even under the worst-case scenario considered.

In summary, the sensitivity analysis carried out highlights distinct cost drivers for different recharging technologies. For DWPT technology, the utilization ratio is the most critical factor, with significant impacts on energy carrier costs, reflecting the high sensitivity to changes in customer usage. Electricity cost has a lesser effect due to the substantial initial investment required, which overshadows operational expenses. In contrast, for public fast-charging technology, the utilization ratio remains a key factor, but electricity cost becomes increasingly significant due to the relatively lower CAPEX and higher OPEX. Finally, for private slow-charging technology, electricity cost dominates due to the high proportion of OPEX compared to CAPEX, and variations in utilization ratio and CAPEX have minimal impact on final costs.

4. Conclusions

Our study aims to conduct a comprehensive techno-economic comparison of three powertrain technologies (ICEV; BEV and DWPT-BEV) for a truck belonging to VECTO group 5. To do this, we also developed a vehicle simulation model to simulate a typical long-haul daily mission spanning 500 km. The simulation results were crucial in evaluating aspects related to the cost of the energy carrier and the cost associated to increased delivery times for the electric trucks. Particularly noteworthy was the BEV truck's challenge in meeting the 500-km daily target within the mandated 45-min rest period for drivers, which posed a significant challenge. Consequently, we opted to divide the journey into three equal segments, necessitating two 35-minute stops for recharging at high-capacity stations providing 350 kW of recharging power. This adjustment resulted in a daily time extension of 25 min compared to the ICE truck. On the other hand, the DWPT-equipped truck presented a promising alternative. By leveraging the DWPT lane infrastructure, only one stop was required for the ICE truck to comply with mandatory driver rest times.

In our economic assessment, we have delineated three distinct scenarios concerning energy carrier costs, encompassing an optimistic, an average, and a pessimistic outlook. Additionally, we have evaluated TCO by integrating projections of cost reductions derived from existing literature about the purchasing costs of specific subsystems (e.g., battery pack) and energy carrier cost reduction.

The main findings derived from our results suggest that, currently, ICE technology continues to be the most cost-effective for long-haul

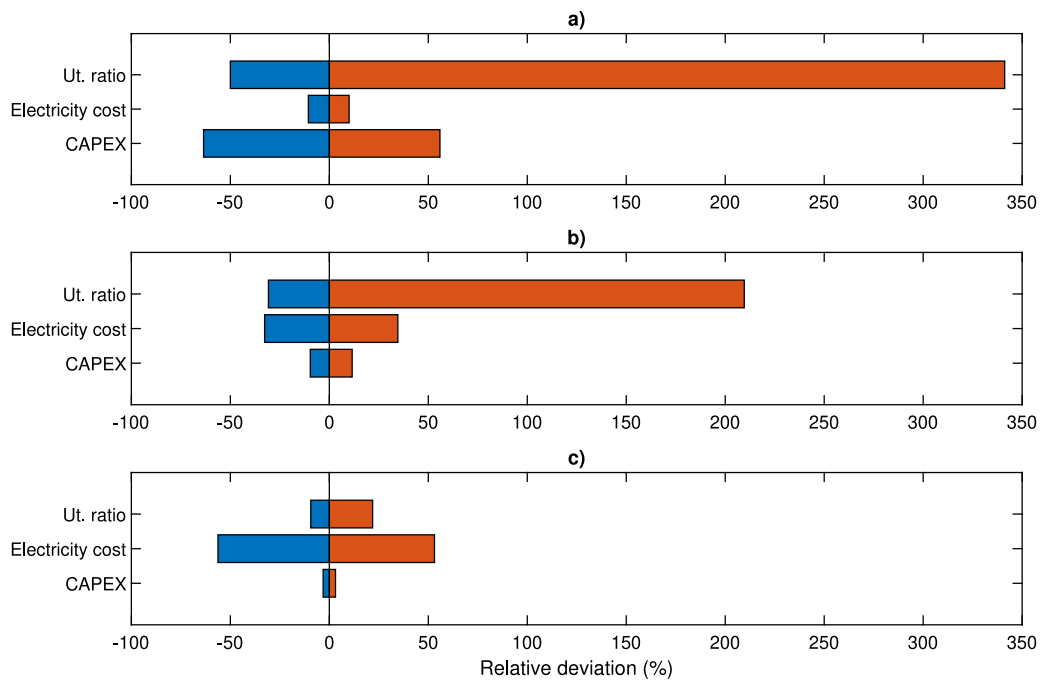

Fig. 6. Sensitivity analysis of energy carrier costs across different parameters, varying each individually. Specifically, panel (a) represents the sensitivity analysis for DWPT recharging technology, panel (b) focuses on public fast-charging technology, and panel (c) examines the slow-charging technology installed by fleet operators at depots.

applications and that cost parity for electric trucks can be achieved in future scenarios can be achieved but is strongly dependent on the energy carrier cost, which is perhaps the most important factor. For the electric trucks, this cost, which is the end-user cost of using the charging infrastructure (slow charging stations, fast charging stations, and DWPT lanes), will strongly depend on the utilization ratio of these infrastructures. Another notable finding is that the time penalty cost has a small impact on the overall total cost of ownership (TCO).

Regarding the 2022 scenarios, we attribute the current lack of competitiveness of electric trucks to the current purchase cost of the two alternative trucks compared to the conventional option, coupled with the recent rise in electricity costs. Regarding the energy carrier cost, our cost model (described in Section 2.2.5) shows that relatively high utilization ratios are needed in order to make the electric trucks cost-competitive with the ICE truck. This is also the only condition under which DWPT becomes cost-competitive with the BEV truck, which only uses stationary charging, because the time penalty cost is always small, accounting for approximately 2% of the total for the BEV truck. However, as we discussed in Section 3.2.3, these results concerning the time penalty cost are dependent on assumptions about the length of the representative daily driving mission (which we set to 500 km) and the assumption that longer delivery times can be compensated by deploying additional trucks, which is built into the model we developed to evaluate the time penalty cost in Section 2.2.6.

We noted a decrease in maintenance costs for BEV and DWPT trucks compared to ICE trucks. However, this reduction only contributes to a small extent towards cost parity. This finding was not surprising and is consistent with previous literature [19,38,41].

Finally, in Section 3.2.5, we conducted a sensitivity analysis to assess the impact of various parameters on the energy carrier costs across three recharging technologies: DWPT, public fast-charging, and private slow-charging technologies. We examined how changes in electricity cost, infrastructure utilization, and CAPEX influence the overall costs. Our analysis revealed that the utilization ratio is the most significant factor for DWPT technology, with substantial cost increases observed at lower utilization levels. Electricity cost plays a less critical role due to the high initial CAPEX. For public fast-charging technology, the utilization ratio is also important, but electricity cost becomes

more influential due to the relatively lower CAPEX and higher OPEX. Lastly, for private slow-charging technology, electricity cost is the dominant factor as OPEX makes up a large portion of the total cost, while variations in utilization ratio and CAPEX have minimal effects. This comprehensive analysis emphasizes the need to consider specific technology characteristics and usage scenarios to accurately evaluate the economic implications of recharging infrastructure.

In conclusion, our analysis highlights the importance of sustained utilization ratios for the dynamic charging infrastructure for DWPT to be a competitive technology. Remarkably, in the average and pessimistic scenarios, the DWPT failed to demonstrate economic competitiveness with BEV. These results might change if a longer daily driving mission was considered or if harsher penalties were considered for untimely deliveries. Furthermore, since the DWPT lane guarantees a higher available range for trucks, there will be opportunities for battery right-sizing and reducing the purchase cost of the truck. Thus, this can be achieved by reducing the potential payload reduction, thereby avoiding possible payload loss costs. Furthermore, other dynamic charging technologies (such as overhead transmission and electrified rail) might be more cost-competitive than DWPT, as suggested by some studies [14] because of the lower investment of the infrastructure and the higher efficiency. Finally, it should be noted that the goal of our analysis is to assess the techno-economic performance of these powertrain technologies regardless of policy interventions. Therefore, our cost model does not take into account the effect of regulatory policies on taxes and on the purchase cost of trucks: for example, no tax incentives were considered for the electric trucks, and no effect of the fleet-averaged mandatory CO₂ reduction targets on the purchase cost for ICE trucks was considered. A future study could enhance this evaluation putting also the financial benefits of the government to make this technology cost-effective.

In future work, we plan to extend our analysis to include alternative dynamic charging technologies, such as overhead transmission and electrified rail. This expansion will allow us to compare these technologies against DWPT in terms of cost, efficiency, and feasibility. Additionally, we will aim to quantify the effect of CO₂ reduction targets and tax incentives in steering the cost-effectiveness towards electrified trucks. By understanding how these factors influence the overall cost

dynamics, we can provide more accurate and comprehensive insights. Furthermore, our analysis will incorporate a complete sustainability assessment, which will evaluate the environmental impacts alongside technical and economic factors. This assessment will include a life-cycle analysis to determine the total environmental footprint of each technology, considering factors such as resource extraction, manufacturing, operational emissions, and end-of-life disposal. We also plan to explore the implications of battery right-sizing facilitated by DWPT lanes, which can lead to significant cost reductions in truck purchases without compromising operational efficiency. This multifaceted approach will provide policymakers with a robust framework for decision-making. By presenting a thorough cost–benefit analysis that includes environmental impacts, we aim to highlight the broader implications of adopting dynamic charging technologies. This comprehensive overview will support the development of policies that not only focus on economic viability but also align with the goals of decarbonizing the transport sector, ultimately contributing to a sustainable and efficient transportation system.

CRedit authorship contribution statement

Trentalessandro Costantino: Writing – original draft, Visualization, Software, Resources, Methodology, Investigation, Formal analysis, Data curation, Conceptualization. **Federico Miretti:** Writing – original draft, Software, Methodology, Investigation, Formal analysis, Conceptualization. **Ezio Spessa:** Writing – review & editing, Supervision, Project administration, Investigation.

Declaration of competing interest

The authors declare that they have no known competing financial interests or personal relationships that could have appeared to influence the work reported in this paper.

Acknowledgment

This publication is part of the project PNRR-NGEU which has received funding from the MUR-DM 352/2022.

Data availability

Data will be made available on request.

References

- [1] Regulation (EU) 2019/1242 of the European Parliament and of the Council of 20 June 2019 setting CO₂ emission performance standards for new heavy-duty vehicles and amending Regulations (EC) No 595/2009 and (EU) 2018/956 of the European Parliament and of the Council and Council Directive 96/53/EC. Off J 2019. URL <https://eur-lex.europa.eu/eli/reg/2019/1242/oj>.
- [2] Proposal for a Regulation of the European Parliament and of the Council of amending Regulation (EU) 2019/1242 as regards strengthening the CO₂ emission performance standards for new heavy-duty vehicles and integrating reporting obligations, and repealing Regulation (EU) 2018/956, and amending Regulation (EU) 2018/858. 2024, URL https://www.europarl.europa.eu/meetdocs/2014_2019/plmrep/COMMITTEES/ENVI/DV/2024/02-14/Item9-HDVs_2023-0042COD_provisionalagreement_EN.pdf.
- [3] Offer G, Howey D, Contestabile M, Clague R, Brandon N. Comparative analysis of battery electric, hydrogen fuel cell and hybrid vehicles in a future sustainable road transport system. *Energy Policy* 2010;38(1):24–9. <http://dx.doi.org/10.1016/j.enpol.2009.08.040>.
- [4] Çabukoglu E, Georges G, Küng L, Pareschi G, Boulouchos K. Battery electric propulsion: An option for heavy-duty vehicles? Results from a Swiss case-study. *Transp Res C* 2018;88:107–23. <http://dx.doi.org/10.1016/j.trc.2018.01.013>.
- [5] Choi W, Yoo E, Seol E, Kim M, Song HH. Greenhouse gas emissions of conventional and alternative vehicles: Predictions based on energy policy analysis in South Korea. *Appl Energy* 2020;265:114754. <http://dx.doi.org/10.1016/j.apenergy.2020.114754>.
- [6] Marmiroli B, Venditti M, Dotelli G, Spessa E. The transport of goods in the urban environment: A comparative life cycle assessment of electric, compressed natural gas and diesel light-duty vehicles. *Appl Energy* 2020;260:114236. <http://dx.doi.org/10.1016/j.apenergy.2019.114236>.
- [7] Regulation (EC) No 561/2006 of the European Parliament and of the Council of 15 March 2006 on the harmonisation of certain social legislation relating to road transport and amending Council Regulations (EEC) No 3821/85 and (EC) No 2135/98 and repealing Council Regulation (EEC) No 3820/85 (Text with EEA relevance) - Declaration. Off J 2006. URL <http://data.europa.eu/eli/reg/2006/561/oj/eng>.
- [8] Taljegard M, Thorson L, Odenberger M, Johnsson F. Large-scale implementation of electric road systems: Associated costs and the impact on CO₂ emissions. *Int J Sustain Transp* 2019;14(8):606–19. <http://dx.doi.org/10.1080/15568318.2019.1595227>.
- [9] Li S, Mi CC. Wireless power transfer for electric vehicle applications. *IEEE J Emerg Sel Top Power Electron* 2015;3(1):4–17. <http://dx.doi.org/10.1109/jestpe.2014.2319453>.
- [10] Chopra S, Bauer P. Driving range extension of EV with on-road contactless power transfer—A case study. *IEEE Trans Ind Electron* 2013;60(1):329–38. <http://dx.doi.org/10.1109/tie.2011.2182015>.
- [11] Huh J, Lee W, Cho G-H, Lee B, Rim C-T. Characterization of novel inductive power transfer systems for on-line electric vehicles. In: 2011 twenty-sixth annual IEEE applied power electronics conference and exposition. APEC, IEEE; 2011. <http://dx.doi.org/10.1109/apec.2011.5744867>.
- [12] Marmiroli B, Dotelli G, Spessa E. Life cycle assessment of an on-road dynamic charging infrastructure. *Appl Sci* 2019;9(15):3117. <http://dx.doi.org/10.3390/app9153117>.
- [13] Amditis. Final Report Summary - FABRIC (FeAsiBility analysis and development of on-Road charging solutions for future electric vehiCles). *CORDIS EU research results European Commission*; 2019, URL <https://cordis.europa.eu/project/id/605405/reporting>.
- [14] Olsson O. Slide-in electric road system, conductive project report, Phase 1. *Viktoria report, Tech. Rep., RISE, Viktoria*; 2014.
- [15] Suján VA, Siekmann A, Tennille S, Tsybina E. Designing dynamic wireless power transfer corridors for heavy duty battery electric commercial freight vehicles. *SAE technical paper series, ANNUAL, SAE International*; 2023, <http://dx.doi.org/10.4271/2023-01-0703>.
- [16] Mingyue S, Ajith VS, Basil S, Douglas W, Prakash R. Economic analysis of dynamic inductive power transfer roadway charging system under public-private partnership—evidence from New Zealand. *Technol Forecast Soc Change* 2020. <http://dx.doi.org/10.1016/j.techfore.2020.119958>.
- [17] David T, Noah H, Regan Z, Ziqi S, Abhilash K, Theodora K, et al. Economic feasibility of in-motion wireless power transfer in a high-density traffic corridor. *eTransportation* 2022. <http://dx.doi.org/10.1016/j.etrans.2021.100154>.
- [18] Paolo L, Vincenzo C, Aldo C. Economic and environmental sustainability of dynamic wireless power transfer for electric vehicles supporting reduction of local air pollutant emissions. *Renew Sustain Energy Rev* 2021. <http://dx.doi.org/10.1016/j.rser.2020.110537>.
- [19] Basma H. Total cost of ownership for tractor-trailers in Europe: Battery electric versus diesel. *Tech. Rep., ICCT*; 2019, URL <https://theicct.org/publication/total-cost-of-ownership-for-tractor-trailers-in-europe-battery-electric-versus-diesel/>.
- [20] Commission Regulation (EU) 2017/2400 of 12 December 2017 implementing Regulation (EC) No 595/2009 of the European Parliament and of the Council as regards the determination of the CO₂ emissions and fuel consumption of heavy-duty vehicles and amending Directive 2007/46/EC of the European Parliament and of the Council and Commission Regulation (EU) No 582/2011. Off J 2017. URL <https://eur-lex.europa.eu/legal-content/EN/TEXT/PDF/?uri=CELEX:32017R2400>.
- [21] Wentzel H. Battery electric and plug-in hybrid vehicles. *Tech. Rep., Paris, France: SCANIA*; 2020, URL <https://www.itf-oecd.org/battery-electric-and-plug-hybrid-vehicles-henrik-wentzel-scania>.
- [22] Pettersson P, Berglund S, Jacobson B, Fast L, Johannesson P, Santandrea F. A proposal for an operating cycle description format for road transport missions. *Eur Transp Res Rev* 2018;10(2). <http://dx.doi.org/10.1186/s12544-018-0298-4>.
- [23] Fontaras G, Grigoratos T, Savvidis D, Anagnostopoulos K, Luz R, Rexeis M, et al. An experimental evaluation of the methodology proposed for the monitoring and certification of CO₂ emissions from heavy-duty vehicles in Europe. *Energy* 2016. <http://dx.doi.org/10.1016/j.energy.2016.02.076>.
- [24] Ellram L. Total cost of ownership: An analysis approach for purchasing. *Int J Phys Distrib Logist Manage* 1995;25:4–23. <http://dx.doi.org/10.1108/09600039510099928>.
- [25] Ellram LM. Total cost of ownership. In: Hahn D, Kaufmann L, editors. *Handbuch industrielles beschaffungsmanagement: Internationale konzepte — innovative instrumente — aktuelle praxisbeispiele*. Wiesbaden: Gabler Verlag; 2002, p. 659–71. http://dx.doi.org/10.1007/978-3-663-01582-6_34, URL https://doi.org/10.1007/978-3-663-01582-6_34.
- [26] Parkhi S. Total Cost of Ownership (TCO). 2014.

- [27] Proposal for a Regulation of the European Parliament and of the Council on type-approval of motor vehicles and engines and of systems, components and separate technical units intended for such vehicles, with respect to their emissions and battery durability (Euro 7) and repealing Regulations (EC) No 715/2007 and (EC) No 595/2009. Off J 2022. URL https://eur-lex.europa.eu/resource.html?uri=cellar:9a25dc0b-60db-11ed-92ed-01aa75ed71a1.0001.02/DOC_1&format=PDF.
- [28] Kuhn. E-truck virtual teardown study. 2021.
- [29] Persyn D, Díaz-Lanchas J, Barbero J. Estimating road transport costs between EU regions. Tech. Rep. 04/2019, 2019, URL <https://joint-research-centre.ec.europa.eu/system/files/2020-05/jrc114409.pdf>.
- [30] Enquête longue distance. Tech. Rep., Comité national routier; 2022, URL <https://www.cnr.fr/enquete-cnr-longue-distance-2022>.
- [31] The German road freight transport sector. Tech. Rep., Comité national routier; 2021, URL <https://www.cnr.fr/en/german-road-freight-transport-sector-2021>.
- [32] The Italian road freight transport sector. Tech. Rep., Comité national routier; 2021, URL <https://www.cnr.fr/en/italian-road-freight-transport-sector-2021>.
- [33] The Netherlands - The Dutch road freight transport sector. Tech. Rep., Comité national routier; 2019, URL <https://www.cnr.fr/en/netherlands-dutch-road-freight-transport-sector-2019>.
- [34] The Polish road freight transport sector. Tech. Rep., Comité national routier; 2019, URL <https://www.cnr.fr/en/polish-road-freight-transport-sector-2019>.
- [35] The Spanish road freight transport sector. Tech. Rep., Comité national routier; 2020, URL <https://www.cnr.fr/en/spanish-road-freight-transport-sector-2020>.
- [36] The UK Road Freight Transport Sector. Tech. Rep., Comité national routier; 2019, URL <https://www.cnr.fr/en/uk-road-freight-transport-sector>.
- [37] 2016 Social Summary of CNR's European Studies. Tech. Rep., Comité National Routier; 2016, URL <https://www.cnr.fr/en/2016-social-summary-cnrs-european-studies>.
- [38] Kleiner F, Friedrich H. Maintenance & repair cost calculation and assessment of resale value for different alternative commercial vehicle powertrain technologies. 2017.
- [39] Weekly Oil Bulletin, URL <https://ec.europa.eu/energy/observatory/reports/List-of-WOB.pdf>.
- [40] Eurostat. Electricity prices for non-household consumers - bi-annual data (from 2007 onwards), URL https://ec.europa.eu/eurostat/databrowser/product/page/nrg_pc_205.
- [41] Burnham A, Gohlke D, Rush L, Stephens T, Zhou Y, Delucchi MA, et al. Comprehensive Total cost of ownership quantification for vehicles with different size classes and powertrains. Tech. Rep. ANL/ESD-21/4, Argonne, IL (United States): Argonne National Lab. (ANL); 2021, <http://dx.doi.org/10.2172/1780970>, URL <https://www.osti.gov/biblio/1780970>.
- [42] Burke A, Miller M, Sinha A, Fulton L. Evaluation of the economics of battery-electric and fuel cell trucks and buses: Methods, issues, and results. 2022, URL <https://escholarship.org/uc/item/1g89p8dn>.
- [43] Green book supplementary guidance: valuation of energy use and greenhouse gas emissions for appraisal. 2023, URL <https://www.gov.uk/government/publications/valuation-of-energy-use-and-greenhouse-gas-emissions-for-appraisal>.
- [44] Costantino T, Miretti F, Spessa E. Improving the feasibility of electrified heavy-duty truck fleets with dynamic wireless power transfer. 2023, <http://dx.doi.org/10.4271/2023-24-0161>.
- [45] Bateman D, Leal D, Reeves S, Emre M, Stark L. Electric road systems: A solution for the future? Tech. Rep., World Road Association (PIARC); 2018, URL <https://www.piarc.org/ressources/publications/10/29699,2018-SP-04EN.pdf>.
- [46] Bernard MR, Hall D. Assessing charging infrastructure needs in Québec. Tech. rep., International Council on Clean Transportation; 2022.
- [47] Ragon P-L, Mulholland E, Basma H, Rodriguez F. A review of the AFIR proposal: Public infrastructure needs to support the transition to a zero-emission truck fleet in the European Union. Tech. Rep., International Council on Clean Transportation; 2022, URL <https://theicct.org/wp-content/uploads/2022/03/review-afir-public-infrastructure-to-support-transition-to-zero-emission-truck-fleet-eu-mar22.pdf>.