

POLITECNICO DI TORINO
Repository ISTITUZIONALE

From theory to flight: the box-wing configuration implications for the next-generation aircraft

Original

From theory to flight: the box-wing configuration implications for the next-generation aircraft / Abu Salem, K.; Palaia, G.; Frediani, A.. - (2024). (34th ICAS International Congress Florence (Ita) 9-13 September 2024).

Availability:

This version is available at: 11583/2995578 since: 2025-02-25T15:36:17Z

Publisher:

n.a.

Published

DOI:

Terms of use:

This article is made available under terms and conditions as specified in the corresponding bibliographic description in the repository

Publisher copyright

(Article begins on next page)



From theory to flight: the box-wing configuration implications for the next-generation aircraft

Karim Abu Salem^{1a}, Giuseppe Palaia^{1b}, Aldo Frediani^{2c}

¹Mul2 Group, Department of Mechanical and Aerospace Engineering, Politecnico di Torino, Corso Duca degli Abruzzi 24, Torino, Italy

²SkyBox Engineering, Via G. Caruso 8, Pisa, Italy

^a*karim.abusalem@polito.it*

^b*giuseppe.palaia@polito.it*

^c*info@skyboxeng.com*

Abstract

This paper aims to present a general overview of the main applications of the box-wing configuration to transport aircraft. In particular, the purpose of the paper is to highlight, through a proper selection of literature references, the performance and functional peculiarities of the box-wing lifting architecture. Two different approaches can be applied when innovations are to be introduced in the context of the aeronautical industry. The first one is the evolutionary approach, aiming to develop incremental innovations to the state of the art, without modifying its main outline; the second one is the breakthrough approach, where functional aspects not covered by current technological development are introduced, providing radical changes to the state of the art. The literature analysis regarding the design development of box-wing aircraft discussed in this paper reveals that a breakthrough approach is necessary for an effective introduction of this innovation in the context of transport aviation. By analysing the applications of box-wing to aircraft of different categories, from medium-haul to regional, from ultralight to urban air mobility, the specific functional and performance potential of this configuration, as well as the limits reached by basic research studies, and the bottlenecks currently preventing its further industrial development, are outlined.

Keywords: box-wing; PrandtlPlane; innovation; next-generation aircraft; aircraft design.

1. Introduction

The study of non-conventional transport aircraft configurations has been a topic widely discussed and investigated in the past and today [1,2]. Among these configurations different from tube-and-wing, the box-wing configuration had wide consideration over the past decades; this architecture is based on the idea of a closed lifting system, composed of two horizontal main wings connected at the tips by two vertical wings; this system, if properly sized, is able to minimize the induced drag. This theoretical aerodynamic concept was already proposed a century ago by Prandtl [3], and an exact solution of the Prandtl's problem was given in ref. [4]; from this starting point in aerodynamics, a great activity was conducted by aeronautical scientists through the years to identify aircraft configurations that could represent a breakthrough in the technological development in transport aviation [5,6]. Specifically, following the conceptual proposals outlined in the reference article ref. [7], the box-wing aircraft, also known as the PrandtlPlane, has been the subject of studies and applications to almost all categories of transport aircraft. This paper, through a systematic and critical review of the scientific and engineering studies available in the literature regarding the application of the box-wing architecture, aims to: i) outline the performance features of the different applications of the box-wing, not only limited to the aerodynamic field, but also with the view to provide a multidisciplinary and holistic perspective on the actual utilization of this aircraft; ii) extend the preceding discussion in order to address and identify potential benefits and drawbacks, and also the associated critical issues related to an effective industrial implementation.

There are two distinct approaches that can be employed when introducing innovations within the aeronautical industry. The first approach, known as the evolutionary approach, focuses on developing innovations that provide incremental improvements to existing technology without fundamentally altering its core framework. Conversely, the breakthrough approach aims to introduce aeronautical

innovations that address functional aspects not currently addressed by existing technology, potentially leading to radical changes in the state of the art. This approach seeks to push boundaries and introduce transformative advancements in aviation technology. In this regard, this paper thoroughly discusses and comments on the results provided by studies in which the PrandtlPlane concept has been applied to different aircraft categories with the aim of exploiting its peculiarities in a different, specific and targeted way. An evolutionary approach leads to little and unlikely performance gains, whereas a breakthrough development, tailored to its peculiar functional capabilities, resulted to be the best way to foster its development.

Although the studies discussed in this paper have increased the basis of engineering knowledge and resulted in several beneficial outcomes from the application of the box-wing concept, there are still several aspects that represent challenges in the development of this configuration, and this paper aims to address them. A century after Prandtl's theoretical insight, have we reached a level of technological maturity that allows the research background on box-wing preliminary design to be transferred into an actual industrial path?

The paper is organized as follows: Section 2 provides a general description of the box-wing configuration, its theoretical background, and the different approaches for its development; Section 3 outlines all the breakthrough applications of the box-wing: medium-range aircraft, regional aircraft, general aviation, ultralight amphibious, freighter, and urban air mobility vehicle. Then, in Section 4 some of the limitations to the industrial development are discussed, and finally Section 5 provides the conclusion.

2. Box-wing lifting system: theoretical background

2.1 Prandtl's Best Wing System

The box-wing configuration derives from the initial studies of Prandtl, that exactly a century ago postulated the theory of the Best Wing System (BWS) in his famous report ref. [3]; according to this theory, the lifting system that minimizes the induced drag, having fixed wingspan and lift, has a box shape in frontal view, and has a prescribed optimal lift distribution. This lift, on the horizontal surfaces, is distributed equally and is elliptical with a constant additional contribution, while it is butterfly-shaped on the vertical connecting tip-wings, see Figure 1-left. Although Prandtl did not formalize his result from an analytical point of view, as discussed in ref. [8], his conclusion has been demonstrated analytically by the fundamental work proposed in ref. [4], which laid the theoretical basis for the subsequent study of such a configuration. Regarding the theoretical in-depth focus of Prandtl's postulate, interesting ideas on solutions with minimum induced drag have been proposed in the refs. [9-12]; these works have shown that the optimal solution in terms of induced drag is not unique, but there are infinite equivalent solutions that can be obtained simply by adding a constant contribution to the optimal circulation of each horizontal lifting surface, see Figure 1-right. This makes it possible to optimize the aerodynamic performance of box-wing lifting systems having different wing loadings on the two horizontal lifting surfaces, offering a very high design flexibility with respect to the constraints of stability and controllability in the longitudinal plane, as discussed in detail in ref. [13]. In addition, Munk's theorems [14] state that the optimal solution of induced drag for a box-wing continues to be valid for horizontally spaced wings or for swept wings. This conclusion, together with the theorems of non-uniqueness of the optimal solution of the Best Wing System, has allowed the effective engineering application of this theoretical concept to numerous transport aircraft, as it will be discussed in this article; in honour of the original intuition, this configuration has also been renamed *PrandtlPlane*.

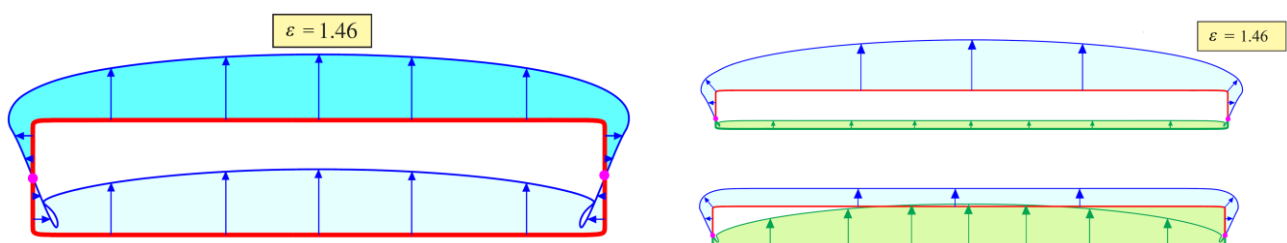

Figure 1. BWS lift distribution (left) and other optimal (right) having the same optimal aerodynamic efficiency ratio ϵ . Image adapted from [6]

2.2 Evolutionary vs breakthrough design approaches

Aircraft design is a long and complex process, which recursively and iteratively intertwines multiple disciplines and makes use of tools and methods of different fidelity in the different design phases. These phases can generally be divided into three macro-blocks, namely conceptual, preliminary, detailed, each of which is characterized by specific tasks and to be carried out with specific sets of tools and skills. Upstream of the whole process, however, are the design specifications, or Top Level Aircraft Requirements (TLARs), which guide the main design choices and allow to initialize the complex design process. In ref. [15], however, even before the selection of TLARs, another concept is introduced, that of *basic requirement(s)*, which serves to identify a specific space defined by qualitative functional objectives that a possible new aircraft design must satisfy; the *basic requirement*, therefore, steers the main technological and architectural choices, even the most innovative and disruptive, which are then to be verified by the designers in a subsequent feasibility analysis phase. Only downstream of the main technological and architectural choices, therefore, is it possible to identify a list of detailed TLARs, as shown in the general diagram of Figure 2.

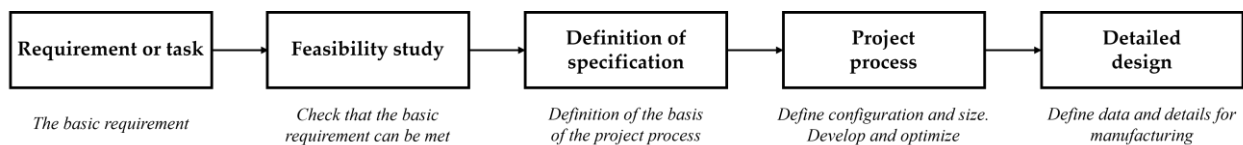

Figure 2. General scheme of aircraft design process according to ref. [15]

Generally, therefore, if there are relevant technological developments, it is possible to identify new *basic requirements* capable of exploring new performance or functional objectives with respect to the state of the art, hence justifying a possible initialization of a new design process. These objectives can be achieved in two different ways: on the one hand, through incremental development (i.e. *evolutionary*) of the current scenario, e.g. in the case of the most recent widebody airliners with a main structure composed almost entirely of composite materials; on the other hand, through the study and integration of completely novel and disruptive technologies with respect to the state of the art, in an approach that can be defined as *breakthrough*, e.g. the case of hydrogen propulsion currently under intense investigations [16]. The *evolutionary* approach, therefore, aims at incremental performance improvements compared to the state of the art, while the *breakthrough* approach aims at satisfying completely new *basic requirements*, which are not reasonably satisfiable by the first approach, and therefore admits the definition of sets of TLARs not present in the current scenario.

Also with regard to the subject of this paper, the box-wing configuration, it is possible to define the development according to the two approaches. In the literature there are several conceptual studies related to the design of box-wing transport aircraft; most of these all follow a same common thread: designing the box-wing aircraft starting from the same TLARs as a conventional aircraft taken as a benchmark and evaluating its performance in an incremental way, according to the most canonical evolutionary approach. This assumption has therefore been interpreted in different ways by various authors who have dealt with the subject: in ref. [17], the conceptual design of the box-wing is driven by a series of very strict assumptions: the box-wing must have the same TLARs as the conventional benchmark, i.e. the Airbus A320, but also the same total wing area and the same wingspan; in addition, the two horizontal wings are constrained to have the same surface. In ref. [17] a 9% saving in fuel consumption for the box-wing is estimated in very preliminary way. However, the constraints imposed on the geometry of the wings, unnecessary from the perspective of the aircraft design initialization, compromise the actual feasibility of the concept, which has extremely slender wings, with aspect ratio equal to 19: more accurate structural and aeroelastic considerations, not addressed in the reference, are likely a showstopper for the development of such a wing system. Also the work in ref. [18] states that for an *effective comparison* it is necessary to maintain the same TLARs and the same wing area of the reference tube-and-wing aircraft, thus forcing the main design choices from the very beginning of the design process. In ref. [19] the same like-for-like approach is preserved, in which the box-wing is designed according to the same TLARs as a regional reference aircraft. In this case, even increases in fuel consumption for the box-wing are estimated, since the comparative approach involves increasing the reference wing area to accommodate the fuel tank volume needed to meet the imposed TLARs; the lifting system, therefore in this approach, is not sized and optimized to meet aerodynamic and aeromechanic requirements and performance, but to meet a requirement unrelated to the aerodynamic design, compromising the aircraft performance potential. Further discussions on the critical issues of the evolutionary like-for-like approach in box-wing development

are commented on in ref. [20]; in general, it emerges that this approach penalises the study and development of configurations and technologies with functional characteristics different from those of the state-of-the-art, such as the box-wing. In fact, fixing the requirements and constraints equal for the two configurations, in order to maintain an impartial comparison, actually has the opposite effect of biasing and distorting the design development of the unconventional configuration. In order to deal with the study of the box-wing in a more sound way, it is therefore necessary to leave the incremental approach and move to a breakthrough one, in which TLARs are established on the basis of the fulfilment of specific *basic requirements* tailored to the functional characteristics of the configuration, as discussed in the next sections for different categories of box-wing aircraft.

3. Applications of the box-wing configuration

This section outlines the applications of the box-wing concept to different aircraft categories. In particular, the focus is given to those applications that didn't derive from an evolutionary development of the state of the art, but that resulted from *basic requirement(s)* specifically tailored to the peculiar functional characteristics of this architecture. Specifically, we will describe and comment on the applications of the box-wing in the field of medium-range transport, regional transport, applications to ultralights and general aviation aircraft, the cargo transport sector, and finally the potential integration in the context of future urban air mobility.

3.1 Medium range aircraft

The reference work related to the application of the box-wing architecture to medium-range aircraft is the one developed in the context of the PARSIFAL project [21]. This project, funded by the European Commission in the context of the Horizon2020 program, had as its main objective the preliminary design and performance analysis of a box-wing aircraft with about 300 seats, capable of covering the typical routes of the current medium-haul sector, i.e. about 5000 km of harmonic range. The box-wing configuration has therefore undergone a detailed multidisciplinary study which, although preliminary, has made it possible to characterize its performance and main peculiarities in all the contexts, including aerodynamics, structures, stability and control, mission performance, environmental, logistic and economic impact. In this section, all the design steps will be briefly reviewed, from the conception of the *basic requirement* to the preliminary design, which led to a general performance characterization of the box-wing in the context of the PARSIFAL project.

The context on which the study and development of this box-wing hinges derives from the definition of three general challenges that commercial aviation is facing currently and in the near future. Firstly, it is generally established by numerous predictive market studies that the increase in demand for air transport is continuously increasing, and with constantly growing rates, in the coming years [22]. The need to increase traffic conflicts with the expanding problem of airport congestion and the related saturation of available slots, especially in the main hubs [23]. Finally, there is an increasingly urgent need to drastically reduce the impact of greenhouse gas emissions from commercial aviation [24-26], which stands in contrast to the growing demand for air traffic. The aeronautical scientific community is making extensive efforts in this direction, with the aim of developing and implementing technological solutions capable of minimizing the environmental impact of transport aviation [27-29]. The scenario consisting of these three main challenges for the aeronautical sector represented the terrain in which the *basic requirement* steering the development of the box-wing within the PARSIFAL project has been defined. In fact, this configuration was considered potentially suitable to meet the three challenges mentioned above in a simultaneous and effective manner. In particular, the box-wing lifting system allows to increase the lift generated without increases of wingspan with respect a tube-and-wing benchmark: this is possible thanks to the presence of two distinct main lifting surfaces. This peculiarity allows to increase the design weight, and therefore to increase the number of passengers transported, without exceeding the airport apron constraints for this category of aircraft. Aircraft operating in the medium range follow ICAO Aerodrome standard 'C', i.e. wingspan must not to exceed 36 meters [30]. The capacity of the lifting system designed according to the theory of the Best Wing System theory also potentially allows to minimize the induced drag, and therefore to obtain such increases in lift without penalizations in terms of lift-to-drag ratio. In summary, these guidelines have made it possible to outline a series of TLARs in a breakthrough and non-evolutionary view, which allowed to initialize the design of an aircraft with operating features completely different from those of traditional competitors operating in the sector. Specifically, it was intended to develop an aircraft with a number of passengers greater than 300, capable of flying at least 5000 km with a full load, and with

a wingspan limited to 36 m; as for conventional aircraft operating in this segment, a cruise condition with a reference altitude of 11000 m and a Mach of 0.79 was chosen.

3.1.1 Design process

The first design studies, regarding the initialization of the early conceptual phases, are reported in [31,32]. These studies focus on some basic and pivotal initial aspects for the effective fulfilment of the demanding design requirements, namely: *i)* the fuselage must be able to accommodate the target number of passengers; *ii)* the lifting system must be able to trim the design weight, must have adequate aerodynamic performance in transonic flight, and must not present critical issues in terms of stability and control; *iii)* the main structures shall be sized according to the minimum weight requirements typical of aeronautical design.

Starting from the first point, the design of the fuselage, it was immediately clear that in order to accommodate a much higher number of passengers than traditional competitors operating in the same sector, it was necessary to discard the classic single aisle cabin layout. Several trade-off studies have led to the definition of a double aisle fuselage, with an almost elliptical section, capable of accommodating 8 passengers per row; the comparison between the fuselage of PARSIFAL and that of an Airbus A320-like aircraft is shown in Figure 3. The design of the fuselage and its layout was also directed by another fundamental requirement, namely the minimisation of turnaround time; this aspect will be discussed later in Section 3.1.2, which describes the impact of operating this aircraft.

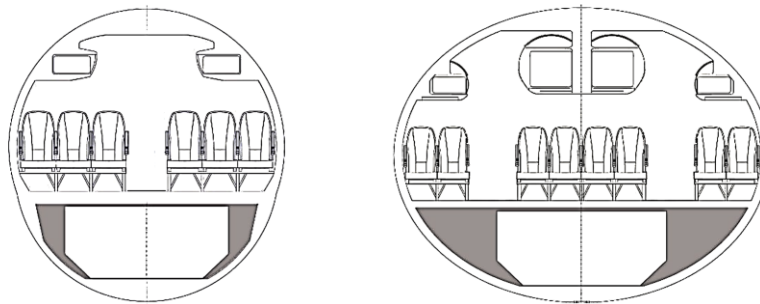

Figure 3. Comparison of cabin layout for 186- (left) and 310- (right) passengers arrangement

The initial structural design of the fuselage was carried out using a code developed ad-hoc for finite element analysis (FEM) of fuselage structures of any geometry. The code, described in ref. [33], is designed to parametrically and automatically generate mesh for fuselage structures of any shape, such as the quasi-elliptical one designed for PARSIFAL. The FEM solver (i.e. Abaqus [34]) considers the combination of the ultimate static load and the pressurization load to carry out the sizing of the structural components of the fuselage, an example of which is shown in Figure 4.

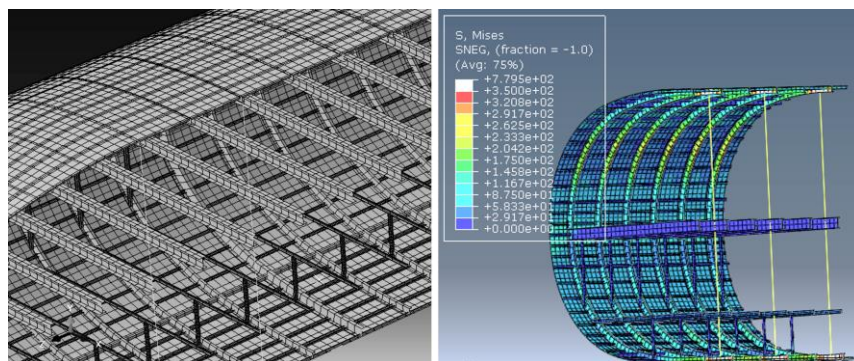

Figure 4. Example of fuselage FEM model (left) and stress output (right). Image adapted from [35]

On the other hand, the design of the lifting system has followed a multidisciplinary development within an increasing fidelity process; this is described in detail in ref. [36] while a brief outline is proposed in the following. As an initial step, the box-wing lifting system is sized by means of a constrained aerodynamic optimization procedure, developed in-house specifically for the conceptual design of box-wing aircraft; the developed code, called AEROSTATE, is extensively described in refs. [37-39]. The objective function to be maximized is the lift-to-drag ratio at the design point, i.e. a preset point of the cruise stage, while the constraints are related to the aeromechanical requirements. In particular, the constraints of vertical equilibrium, i.e. lift equal to weight, and pitch, i.e. zero moment coefficient

at the design point without any deflection of elevators, are imposed. The constraint on longitudinal static stability is also set, i.e. the stability margin is constrained within a specific positive range. Other constraints regarding the wing loading of each lifting surface, their geometry, stall, etc., can be integrated. The assessment of the stability derivatives, lift coefficient, pitching moment, and induced drag is done by means of the Vortex Lattice Method (VLM) implemented in the AVL solver [40]; the components of parasitic drag are evaluated by means of methods proposed in refs. [41]. The aerodynamic-aeromechanical coupling in the design of the box-wing is of fundamental importance, as the horizontal lifting surfaces simultaneously perform the tasks of generating lift for vertical trim, and of handling the correct longitudinal positioning of centre of pressure and neutral point, to ensure controllability and pitch stability. The box-wing lifting configuration, through the possibility of leveraging on numerous design variables defining the geometry (chords, twist, sweep and dihedral angles, longitudinal positioning, taper ratio, see Figure 5-left) proves to be extremely flexible in fulfilling the constrained optimization problem described above, offering several feasible solutions; a small group of configurations representing an output of a single run of the optimization procedure, as a general example, is shown in Figure 5-right.

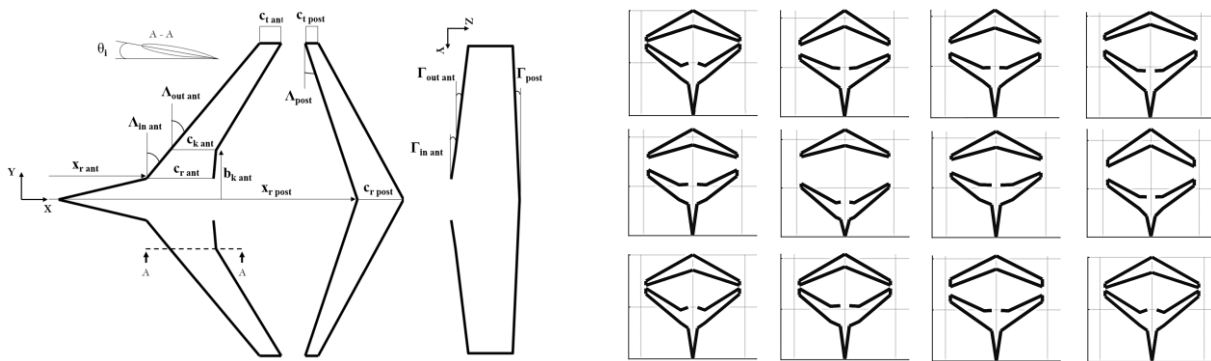

Figure 5. Box-wing design variables (left); example of output of a single run of AEROSTATE (right)

This conceptual procedure provides valuable information for the subsequent development of the aerodynamic design; however, given the limitations of the potential VLM code, it is not possible to obtain information about the effects of compressibility and wave drag, which for the considered cruise Mach can have significant and not negligible effects. Different campaigns of steady CFD RANS numerical simulations were carried out to evaluate the compressibility effects in different phases of the aerodynamic design development; the first, described in ref. [42], served as a parametric study to highlight the macro-critical issues of the box-wing configuration in transonic flight, especially with a view to its peculiar geometric characteristics (e.g. the geometry of the vertical tip-wings and the fillet with the horizontal wings, see Figure 6-left) and to the macro-parameters, such as wing loading or sweep angles. These results were useful to calibrate the boundaries of the design variables during the conceptual investigation phase, with the aim of reasonably eliminating the main aerodynamic performance penalties related to transonic drag rise. A second CFD RANS analysis campaign was carried out at a later stage after the conceptual design; during this campaign, only a couple of configurations selected from the conceptual exploration were used for the aerodynamic refinement based on local adjustments and shape optimization techniques (Figure 6-right), as described in detail in ref. [43]. Finally, once the final configuration of the design process was defined, a final CFD analysis campaign was carried out to accurately evaluate the aerodynamic performance of the PARSIFAL box-wing configuration [44], and to implement this information within the mission simulator to assess mission performance, see Section 3.1.2.

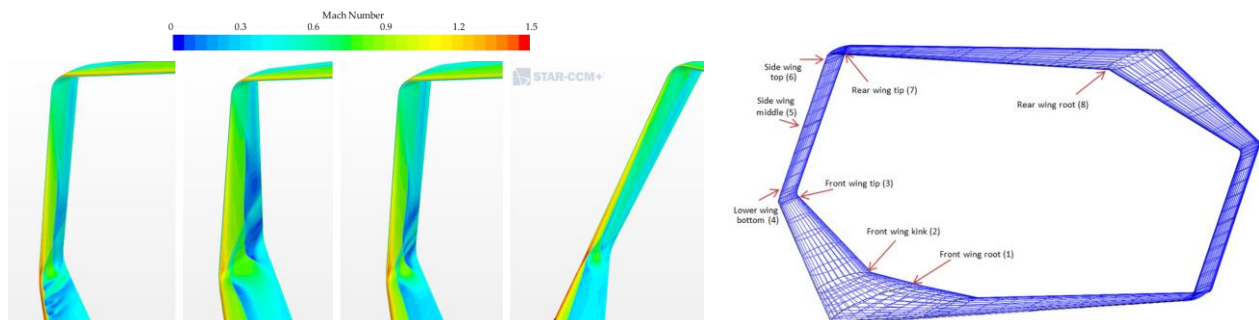

Figure 6. Mach contours on box-wing for different tip-wing geometries (left); box-wing design variables used for the optimization (right)

The same increasing-fidelity approach was used to carry out the sizing and the optimization of the main structures of the lifting system. As mentioned above regarding the fuselage, also for the wing structures the in-house automatic mesh generator was used for FEM models of the analysed box-wing, see Figure 7. These models were exploited to carry out large-scale conceptual evaluations of the structural masses of several configurations designed by AEROSTATE, exploiting the high computational efficiency of the parametric approach for structural studies. The structural sizing procedure considers only static loading conditions. Once the most promising configuration for the detailed development had been defined, the main structure of the lifting system was optimized to minimize weight, according to the FEM-based multi-scale procedure described in detail in ref. [45].

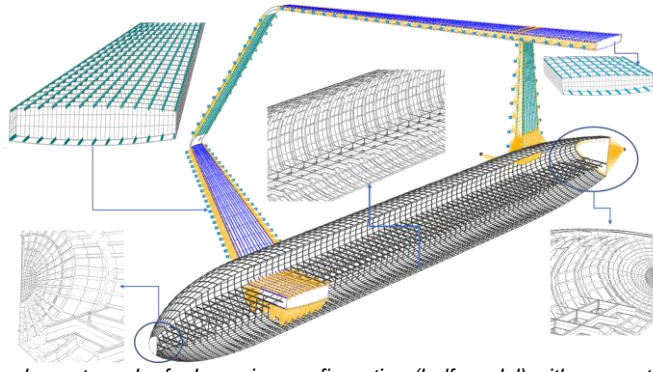

Figure 7. Finite element mesh of a box-wing configuration (half-model) with some structural details.

The multidisciplinary approach also involved aeromechanical aspects, related to the stability and controllability of the box-wing architecture. As mentioned above, these aspects have been integrated into the conceptual optimization procedure defined for the design of the lifting system. In parallel, dedicated investigations were also carried out to evaluate the adequacy of the methods used (see ref. [46]) and to preliminarily characterize the aeromechanical behaviour of this peculiar configuration (see ref. [13]). Specifically, ref. [46] presents an overview of the reliability and limitations that occur using theoretical models established for conventional aircraft also for aeromechanical evaluations for box-wing aircraft. Potential aerodynamic solvers, such as the VLM, have been found to be reliable for aeromechanical evaluations in the longitudinal plane, at least in the conceptual design phases. On the basis of these results, the work proposed in ref. [13] presented a general study on the aeromechanical characterization in the longitudinal plane of the medium-range box-wing aircraft being developed in the context of PARSIFAL, and on the impact that stability and controllability constraints have on the sizing of the box-wing lifting system. The main generalizable result obtained in this study shows that the box-wing aircraft does not present critical issues in terms of stability and longitudinal controllability; the key design parameter impacting on the longitudinal aeromechanical features is the ratio between front-rear wing loading. In general, the front wing must be sized to have a higher wing loading, and the ratio should vary between 0.5-0.75. Figure 8-left shows the front and rear wing loading trends for families of medium-range box-wings sized by AEROSTATE taking into account the PARSIFAL design requirements; in particular, it is observed that by simultaneously introducing the stability and trim constraints in the longitudinal plane, the rear wing must be sized with a lower wing loading L/S ; this introduces a penalty in terms of overall L/D of the aircraft, see Figure 8-right.

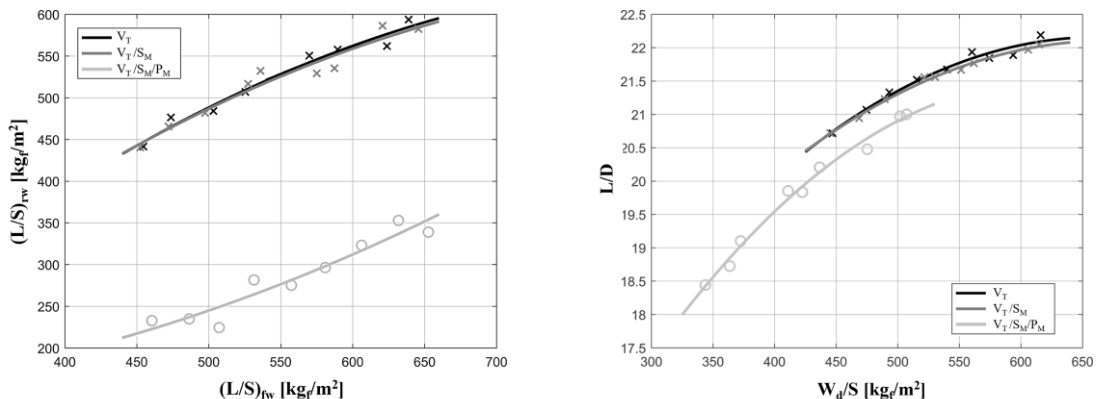

Figure 8. Front and rear wing loadings L/S (left) and lift-to-drag ratio (right) trends for families of configuration fulfilling vertical trim V_T , longitudinal static stability S_M , and pitch trim P_M . Image taken and adapted from [13]

The study proposed in ref. [13] also offered interesting insights regarding low-speed aeromechanical performance; the focus was on the conceptual investigation of the design of high-lift systems. The main outcomes revealed that for a properly sized box-wing lifting system, it is the front wing the most critical to the stall, and consequently the overall low-speed performance of the aircraft (i.e. C_{Lmax}) is directly related to the performance of the flapped front wing. On the other hand, rear wing only needs more simplified high-lift systems specifically designed for pitch trim fulfilment, as the front flap deflection introduces significant pull-up moments. For the detailed description of this problem, please refer to ref. [13].

Other aeromechanical studies in the context of the characterization of the box-wing aircraft developed in PARSIFAL concerned the control techniques and some related innovative implementations. As shown in Figure 9 and preliminarily described in refs. [47,48], the box-wing configuration allows different positioning of the control surfaces on both wings, thus enabling the possibility of integrating unconventional control logics. The study on the optimal layout of the control surfaces, and the multiple possibilities of achieving it, is proposed in ref. [49]; the outcomes show that the possibility of installing a large and redundant number of control surfaces with multi-functions allows to obtain the required flight quality targets in a very effective way. The work proposed in ref. [50] has shown how through advanced control design techniques, it is possible to implement logics such as direct lift control (DLC) and pure pitch control to optimize the landing precision, height gain manoeuvre in cruise, or to improve passenger comfort during flight in gusts. The DLC function has also been explored in ref. [51] to investigate potential benefits that can also be obtained in terms of mission performance.

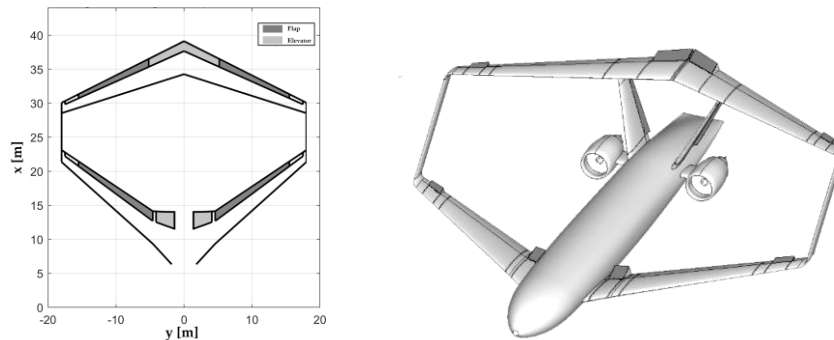

Figure 9. Movable arrangement with contra-rotating elevators on both wings (root area), ailerons (tip area), and flaps (center area)

In general, an extensive summary of the multidisciplinary design operations of the medium-range box-wing, from the definition of the requirements to the performance analysis, is given in ref. [52]. The geometry of the reference box-wing developed in this context are shown in Figure 10, together with that of the CeRAS CSR-01 [53].

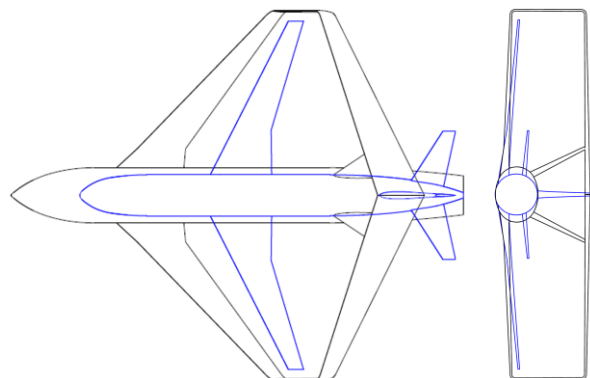

Figure 10. Comparison of top view (left) and front view (right) between PARSIFAL and CeRAS. Image taken from [52]

3.1.2 Impact analysis

The studies downstream of the design activities, i.e. those relating to the performance analysis and the evaluation of the impact of the actual operations of this aircraft, have been fundamental to quantitatively clarify whether the improvements theoretically expected from this concept were actually achievable. In this regard, the performance of the medium-haul box-wing, and its repercussions in the following thematic areas, were investigated: mission performance, operating capabilities and productivity, airport logistics and ground performance, emissions, costs and value creation. The mission performance analysis was carried out by introducing all the design aspects, described in

Section 3.1.1, within a mission simulator, as described in ref. [52]; the outcomes offered interesting insights into the operating capabilities of the aircraft (i.e. payload-range combinations) and the related fuel consumption. The payload-range diagram shown in Figure 11, compared with that of the conventional reference aircraft CeRAS CSR-01 [53,54] (i.e. an open platform that collects data relating to an aircraft similar to the Airbus A320) highlights the superior operating capabilities of the box-wing. In particular, by designing and developing medium-range box-wing according to the logic and design drivers described in Section 3.1, it is possible to cover a payload-range envelope significantly larger than the competitor, while operating from the same airport aprons. The box-wing aircraft developed in PARSIFAL is clearly able to meet its TLARs, leading to an increase of the number of passengers by 66% compared to the competitor, but it is also able to cover the ‘middle of the market’ segment [55], and partially the long range sector. With the same number of passengers as the reference tube-and-wing, the box-wing aircraft can increase the route length by 95%. This aircraft, therefore, opens up completely new operating scenarios that cannot be covered by conventional aircraft, providing to air operators new ways of managing and organizing the air transport market.

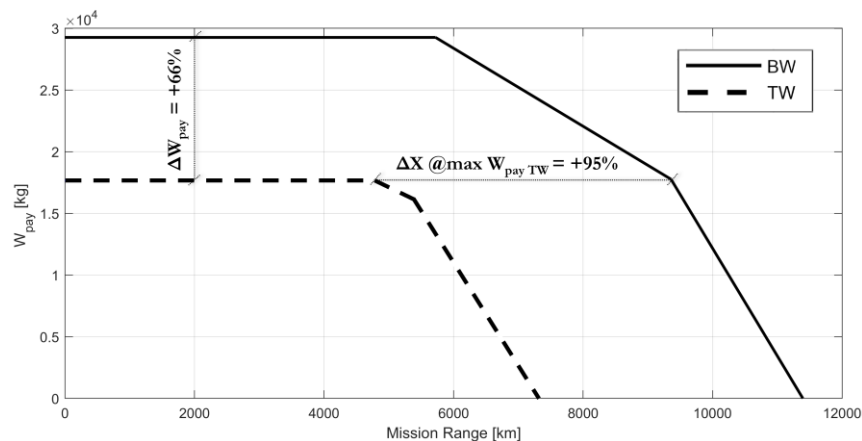

Figure 11. Payload-range envelopes comparison

The operating benefit, however, must also be accompanied by improved fuel consumption performance. The improved aerodynamic performance of the medium-range box-wing aircraft, in fact, could reduce the energy demand of the flight and thus lead to a saving in fuel consumption per passenger transported. The results in terms of comparison of block fuel (m_{bf}) consumption per passenger-kilometre between the box-wing and the competitor CeRAS are reported within the payload-range envelope in Figure 12; the payload was expressed in terms of the cabin load factor to uniform the scale of the diagrams and ease the visualization of the results. It should be noted that the evaluations related to aerodynamic performance, structural and propulsion mass, masses of systems and furnishings, and assumptions on the mission profile, were assessed by means of the same techniques, models and methods for the two configurations; in other words, only the geometry of the CeRAS was extracted from the database, while all other technical evaluations were carried out with the same models, to obtain comparable results. From the analysis of Figure 12 it can be observed that the box-wing offers a reduction of block fuel per passenger-kilometre throughout the operating area of interest of the payload-range envelope; in particular, compared to CeRAS, there are reductions in m_{bf} per pax-km between 13% and 22%.

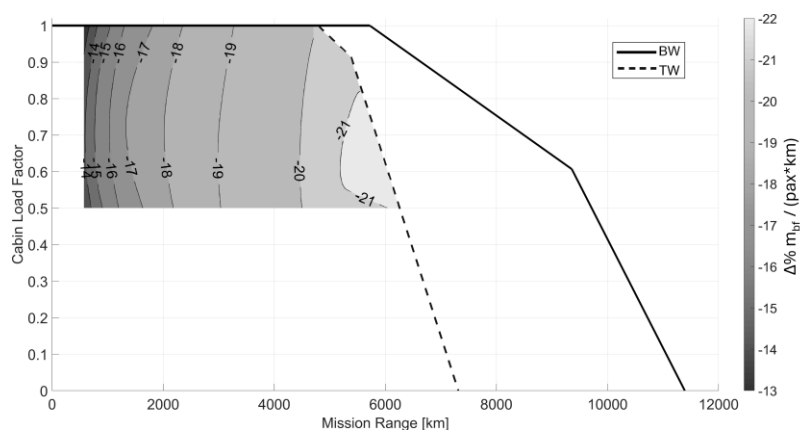

Figure 12. Payload-range envelopes comparison and block-fuel difference for each mission

That performance is also directly reflected in the environmental impact resulting from the utilization of that aeroplane. An extensive detailed study dedicated to the assessment of the environmental impact in terms of polluting and greenhouse gas emissions is offered in ref. [56]; in this study, the emissions of the box-wing were calculated and their impacts were evaluated in terms of Global Warming Potential (GWP), a metric that quantitatively defines the effects of emissions on climate change (for more details on these metrics, please refer to refs. [56,57]). In general, it has been found that compared to the reference aircraft, i.e. the aforementioned CeRAS, the introduction of the box-wing medium-haul aircraft could bring considerable benefits in terms of climate impact in the reference air transport sector; in particular, reductions of 20% in CO₂ and SO₂ emissions and 15% in unburned hydrocarbons per passenger-kilometre were found at the design point, while variations in CO and NO_x are negligible. In general, a GWP reduction of about 18% is achieved, favouring the general reduction of the climate-changing impact of air transport.

Another key aspect to be evaluated when analysing the integration of a new aircraft into the air transport system is its compatibility with the airport infrastructure and its impact on ground performance. The aircraft has been designed to maintain complete compatibility with current infrastructures, therefore airports do not require the introduction of invasive modifications, additions or adaptations to the current system, see the artistic representation proposed in Figure 13-left. The main ground performance is the turnaround time, i.e. the time the aircraft is on the ground between one flight and another, see ref. [58]. Such a performance has a decisive impact on the marketability of a new aircraft, and on its potential to create value, and must therefore be carefully taken into account [59]. Due to PARSIFAL's design requirements and the characteristics of its high-density fuselage, this performance could have been critical and limiting, as the significant increase in passengers compared to those of aircraft operating in the same segment, and the design of the double-aisle fuselage, could have caused excessive increases in turnaround time. For this reason, from the early design phases, these aspects have been strongly taken into account in the development of the aircraft, and at the same time turnaround time evaluation models and simulation platforms have been developed. These aspects mainly impacted the choices related to the design of the fuselage; in particular, in order to allow a faster boarding/de-boarding of a much higher number of passengers than the competitors in the sector, a solution with three main doors was chosen, as proposed in Figure 13-centre. In addition, to speed up boarding/de-boarding operations, the two corridors have been designed with a larger width than that of single-aisle aircraft. Specifically, the aisles of the box-wing have a width of 700 mm, compared to 480 mm for the single aisles, ensuring the possibility of a double flow of passengers per aisle, see Figure 13-right. This allows to avoid the total obstruction of passenger flow when someone stops to put the luggage in the overhead bin, which currently represents the first source of slowdown in boarding/de-boarding operations.

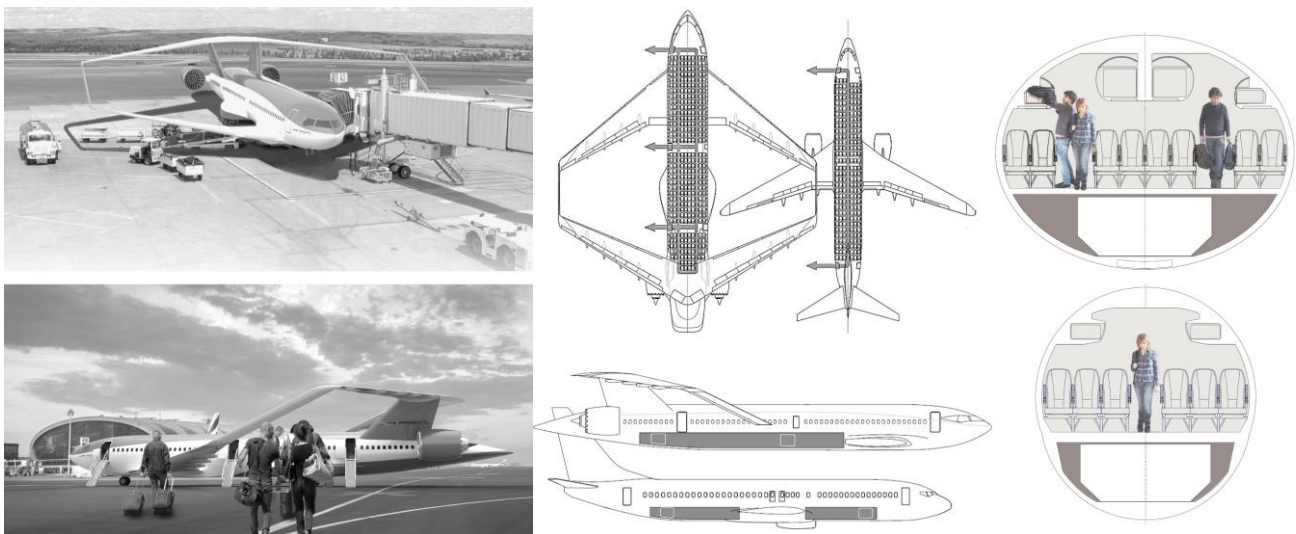

Figure 13. Design choices towards airport compatibility and turnaround time minimization: full-service terminal and outstation operations (left); three-doors and two-aisles cabin arrangement and uninterrupted cargo bay (center); cabin section layout with enlarged aisles (right).

The boarding/de-boarding process was simulated using the SimBaD tool, developed specifically to carry out this task. The tool, widely described in ref. [60], has been built to take into account the geometric characteristics of the passenger cabin, and was validated by means of quantitative data available in the literature. In particular, by means of a discretization in elementary cells of the space

inside the cabin, and considering passengers as finite state machines, it was possible to simulate the processes of passengers boarding/de-boarding, taking into account the randomness of the process and the potential interferences in the passengers flow. The simulations showed that, despite the huge increase in passengers (+66%) and containers (+71%) transportable by the box-wing developed in PARSIFAL, there are limited increases in turnaround time compared to the competitor CeRAS CSR-01, thanks to the appropriate design choices made in this direction. In particular, for outstation operations, the increase in turnaround time is calculated at about 11%, while for full service operations at the terminal the increase is estimated at 25%. Other design choices that have been considered towards the turnaround time reduction consist of: *i*) the installation of compact autonomous ladders ('airstairs'), which allow the aircraft to board/de-board passengers autonomously during outstation operations, see Figure 13-left; this design integration was possible in an efficient way thanks to the extreme low clearance of the fuselage to the ground, since no under-wing engines are installed; *ii*) the advanced longitudinal position of the front wing allows the design of a single cargo bay compartment without any interruption (Figure 13-centre), allowing to speed up the process of loading-unloading luggage and cargo.

Evaluations on the turnaround time, as mentioned, are fundamental for assessing the actual economic performance of a new aircraft. Staying on the ground for too long would result in reductions in revenue-generating operations, and thus could effect in the failure of the project. From an economic implementation perspective, in fact, technical activities (even technologically advanced ones) must ensure an effective integration into the market and the meeting of the demand, potentially being able to generate revenues that are higher than costs (value creation). This economic performance must be carried out from the early stages of product conceptualization, especially for innovative ones that would require large investments, as in the case of the box-wing. In refs. [61,62], the methodology used to assess the economic impact of the development and utilization of the box-wing in the medium-haul market is described in detail, together with the comparison with the CeRAS CSR-01 reference; this methodology is based on the estimate of the direct operating costs DOC [63,64] and the evaluation of the net present value (NPV) [62]. Considering the box-wing developed in the PARSIFAL project, it has been calculated that this aircraft can introduce cost reductions per available seat-kilometre equal to 12% compared to CeRAS, with an impact on the potential possibility of reducing ticket prices by 13% at the same break-even point. Finally, the box-wing could introduce both cost and revenue benefits, adding another positive piece to the overall impact of its actual use in a real-world scenario. A summary of the results of the overall impact analysis of the PARSIFAL box-wing medium-range airliner is reported in Figure 14.

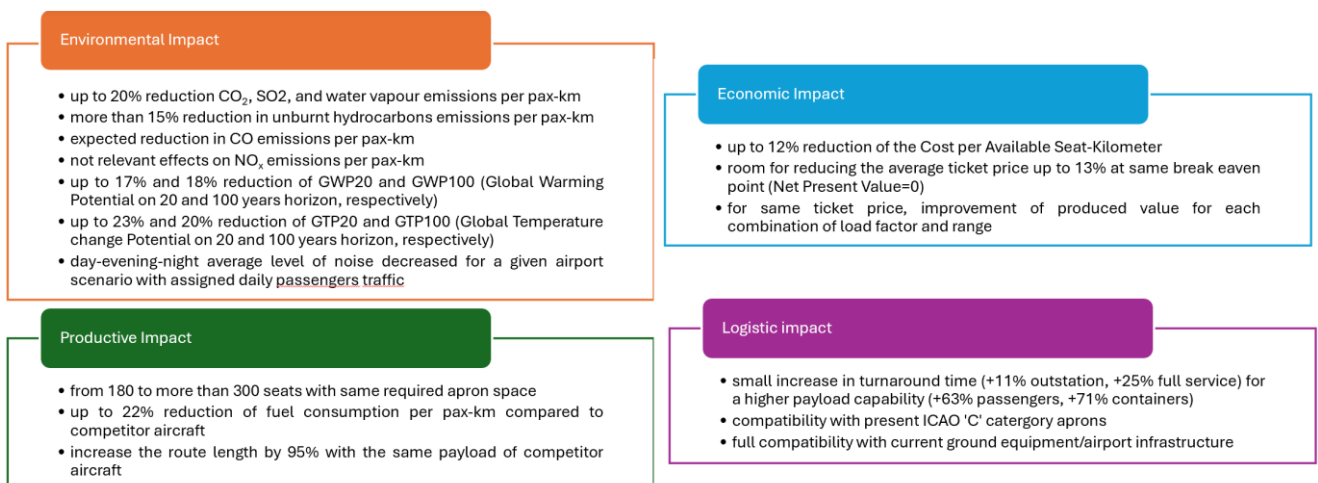

Figure 14. Summary of impact from PARSIFAL box-wing utilization. Scheme adapted from [65]

3.2 Regional aircraft

Another interesting application of box-wing lifting architecture lies in the emerging field of electric and hybrid-electric transport aircraft [66]. This novel propulsion technology aims to represent an alternative to the state-of-the-art capable of significantly cutting greenhouse gas emissions. There are therefore numerous studies relating to the application of electric and hybrid-electric propulsion to aircraft of all scales and categories, such as commuter [67,68], regional [69,70], and medium-range [71,72]. The main technological limitation of this propulsion is related to batteries, which are a component with a

low gravimetric energy density, and which can therefore lead to significant weight increases for transport aircraft, compromising their performance or even their feasibility [73]. Considering the forecasts of battery technological development for the next two decades, in general, it is unlikely that such a propulsion technology can be applied with performance benefit to medium-haul aircraft, or larger; therefore, the main focus is currently on aircraft belonging to the regional category. In this context, the box-wing configuration has been designed and optimized to meet a different *basic requirement* than what is discussed in Section 3.1; in fact, in this case, the larger lifting capacities of the box-wing system have been exploited to balance the weight increases resulting from the installation of the heavy battery packs necessary for the effective use of hybrid-electric powertrains. The feasibility study following this *basic requirement* was carried out through an extensive design campaign and conceptual performance evaluation through a tool developed specifically for this task; the tool, called THEA-CODE (Tool for Hybrid Electric Aircraft COncceptual DEsign) and widely described in refs. [74,75], is a multidisciplinary design platform that integrates aerodynamic, structural, propulsion and performance aspects in a classic iterative design cycle, as schematically depicted in Figure 15.

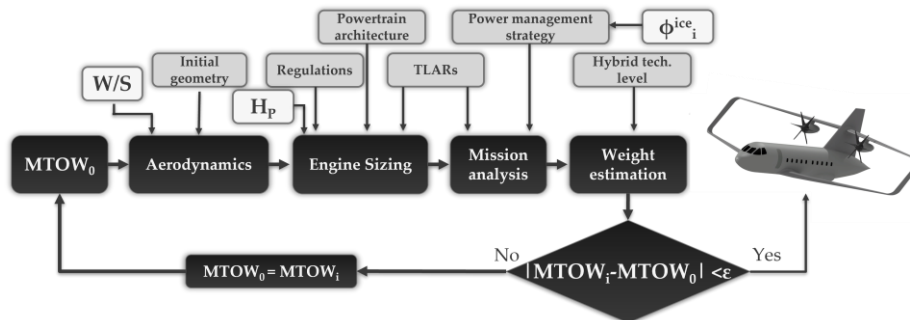

Figure 15. THEA-CODE schematic workflow; image adapted from [76]

The aerodynamic module follows the same polar curve prediction modes built into AEROSTATE, as briefly outlined in the previous section; lift and induced drag are calculated by VLM, while parasitic drag components are evaluated according to the component build-up method described in more detail in ref. [75]. The module relating to the sizing of the hybrid-electric powertrain has the role of assessing the installed power through the matching-chart tool, a diagram that contains the regulatory constraints relating to the power required for each phase of flight, and that correlates it with the wing loading of the aircraft. In the case of hybrid-electric propulsion, the installed power must be divided between the thermal and electric power chains, depending on the selected powertrain architecture, the chosen hybridization factor (i.e. the ratio between electric installed and total installed power), and the power supply strategy chosen to accomplish the mission. In the case of the regional box-wing discussed in this section, the selected propulsion architecture is the parallel one, see Figure 16 and refs. [69,74], for which thermal and electrical sources can supply power to the propeller independently; the electric motor and the internal combustion engine are connected to the propeller by a gearbox.

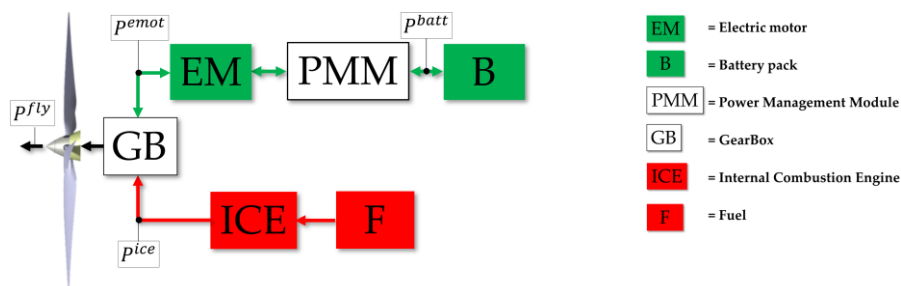

Figure 16. Simplified scheme of a parallel hybrid-electric powertrain

This architecture therefore makes it possible to manage the supply of power and energy during flight according to different split strategies between the thermal and electrical chains, following the constraint that the power supplied by the powertrain is equal to the power required at each instant of the flight. The power management strategy is therefore inserted within a larger mission simulator which, through the time-integration of the dynamics equations of the aircraft considered as a point mass, is able to derive the mission trajectory, the time profiles of thermal and electrical power output, and the mission performance in terms of fuel and electricity consumption, and therefore of the mass

of the batteries. Full details on hybrid-electric aircraft mission simulation and power split management strategies can be found in ref. [76]. The weight of the lifting system is calculated using a surrogate model based on a FEM simulation database [77], while the weight of the fuselage, landing gear, operating items and on-board systems is evaluated using the model provided in ref. [78]. The design procedure ends if convergence is achieved on the MTOW. The power split management strategy for the hybrid-electric regional aircraft can be optimized to minimize different mission performance figures such as emissions, cost, weight, energy, and fuel consumption. The work proposed in ref. [79] provided a general overview of the optimization of the power split management strategy of a generic hybrid-electric regional aircraft, showing that if fuel consumption is to be minimized, it is necessary to provide for large significant weight increases compared to state-of-the-art regional aircraft. This conclusion is in accordance with the *basic requirement* guiding the study and development of the regional box-wing with hybrid-electric propulsion. The conceptual study of this concept, its development, and the performance analysis are described in detail in ref. [80], in which different configurations have been evaluated by varying the maximum take-off weight, and with the aim of minimizing block fuel. The various box-wing configurations have been sized to carry 40 passengers for a distance of 600 nm, with a cruise Mach of 0.4 at an altitude of 6100 m; the take-off length must not exceed 1100 m, while the wingspan must be less than 36 m, compatible with the ICAO Aerodrome Code 'C'. An artistic representation of a generic hybrid-electric regional box-wing configuration is shown in Figure 17.

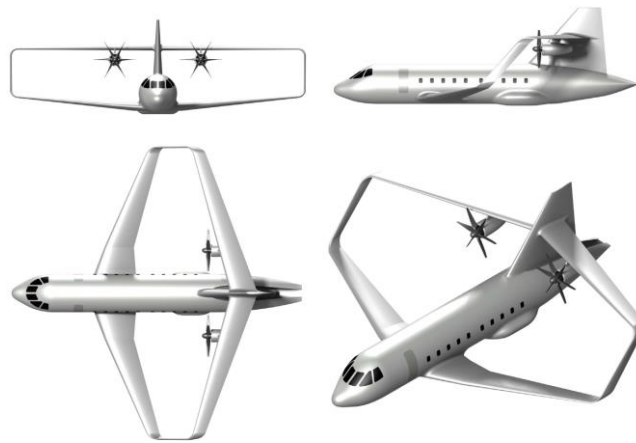

Figure 17. Artistic representation of regional box-wing hybrid-electric configuration; image taken from [80]

By gradually relaxing the constraints on maximum take-off weight, and thus allowing an increasing amount of batteries to be carried on board, the studies proposed in ref. [80] showed that the hybrid-electric regional box-wing aircraft would be able to lead to fuel-efficient solutions for the most relevant operating scenario. This is represented by the results proposed in Figure 18, which reports three different performances of the aircraft within the passengers-range diagram: the block fuel consumption (left), the mass of batteries (centre) and the take-off weight (right). This overview is interesting from an operational point of view, since this category of aircraft is most often operated for pax-range combinations lower than the design point [81]. These results were obtained through an optimization procedure that, by acting on the split of power supply in the different phases of the mission, sought for solutions with minimum fuel consumption; details on mission optimization can be found in ref. [76]. As can be seen in Figure 18, four different configurations with different MTOW (23, 30, 40, 50 tons, respectively) have been optimized. What is observed is that the box-wing with the largest MTOW (50 tons) is able to fly practically the entire operating envelope without any fuel consumption in the standard mission. Configurations with MTOW of 30 and 40 tons allow for significant fuel reductions, with large portions of the pax-range envelope nearly block fuel free. On the other hand, the mass of batteries gradually increases in the corresponding areas where block fuel is minimal, see Figure 18-centre; this increase, however, stops when the maximum MTOW constraint is saturated: beyond this threshold, in order to finalize the mission, it is necessary to 'swap' the mass of batteries for fuel. These zones are identifiable in the block fuel maps (Figure 18-left) in the areas where the isolines begin to appear, and equivalently in the W_{TO} maps (Figure 18-right) where, beyond the rightmost isoline, the aircraft take-off weight remains constant and equal to the MTOW.

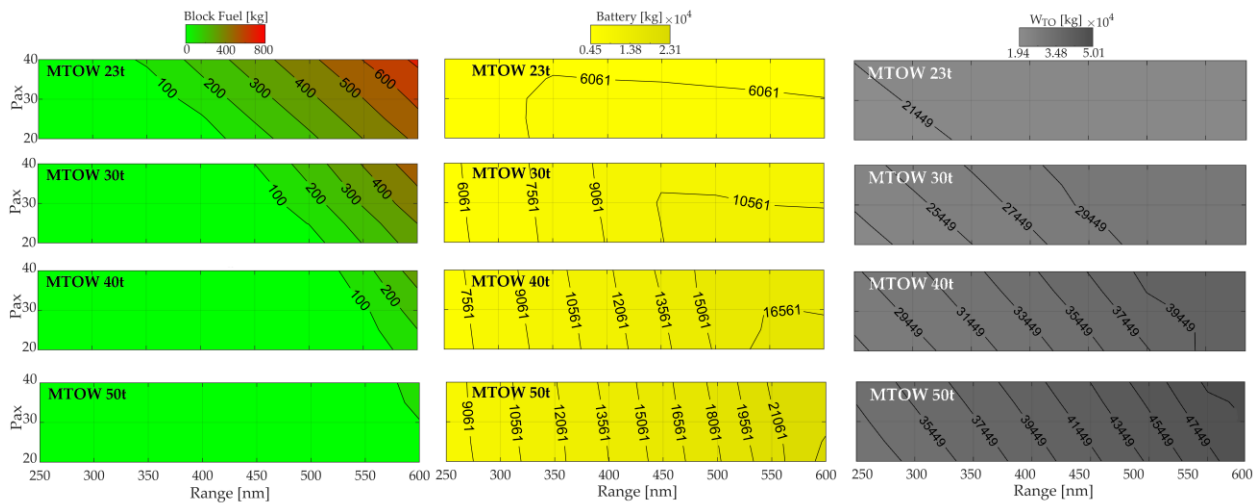

Figure 18. Maps of block fuel (left), battery mass (center), take-off weight (right), inside the pax-range diagram for the regional box-wing aircraft designed for different MTOW. Image adapted from [80]

It is clear that hybrid-electric aircraft optimized to minimize fuel consumption must pay a high trade-off in terms of increased MTOW, and that the aircraft lifting architecture must be able to balance these significant weight gains in an energy-efficient manner. The box-wing solution, on the basis of what is reported in ref. [80] seems to be a valid candidate in this sense, at least on a conceptual level. To verify that these performance and functional advantages were significant compared to traditional architectures, the same design tools and approaches described above were used to design several regional hybrid-electric aircraft with the tube-and-wing configuration, and an extensive performance comparison was carried out. Comparative design and performance analysis activities between hybrid-electric box-wing and tube-and-wing aircraft are reported and discussed in ref. [82]. In this case, the comparative approach was straightforward, with regional aircraft designed for the same requirements and with the same constraints on the MTOW. In the design phase, the main difference found between the two configurations lies in the different structural mass of the lifting system with the same MTOW; this was evaluated by means of the procedures described in ref. [77], in which FEM-based surrogate models considering the static sizing loads were used to optimize the structure of the wing-boxes of both architectures, according to the parameters highlighted in Figure 19-left.

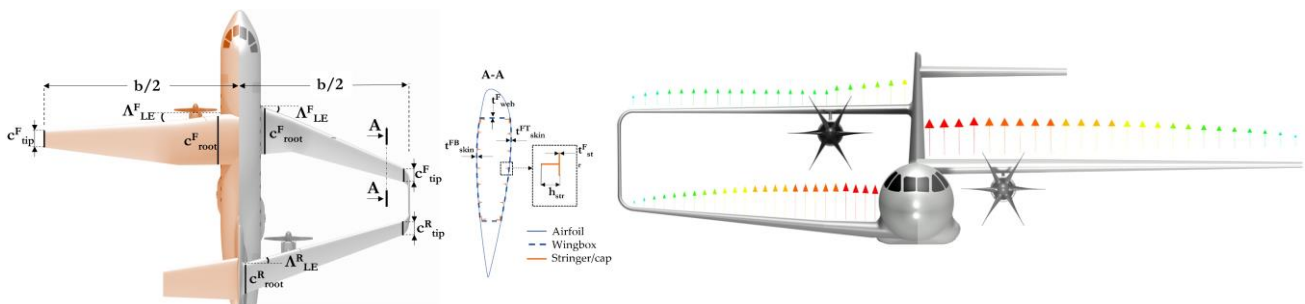

Figure 19. Geometrical and structural design variables describing the lifting system (left); sketch of the lift distribution for box-wing and tube-and-wing configurations. Image adapted from [82]

It is possible to list in a general way some of the main differences inherent in the structural sizing of the lifting system of the two configurations, considering the same design weight: *i)* firstly, as can be seen from the scheme in Figure 19-right, the lift is divided between two main lifting surfaces for the box-wing, while it must obviously be generated from a single surface as far as the tube-and-wing is concerned. As a result, when considering similar wing loadings, the main wing of the tube-and-wing has a larger surface area and span, and is subject to a larger bending moment than those of the individual wings of the box-wing. In addition, the main wing of the tube-and-wing is a cantilever structure, whereas the lifting system of the box-wing is overconstrained to the fuselage. In the end, the smaller wingspan, the different constraint condition, and the lower lift acting on the single wing of the box-wing, provide less severe loading conditions, and therefore the possibility of designing lighter primary structures; *ii)* the box-wing lifting system intrinsically performs the aeromechanical functions necessary for flight in the longitudinal plane, i.e. vertical trim, static stability, and pitch control. For tube-and-wing configurations, on the other hand, this is possible only with the introduction of an additional surface, i.e. the horizontal stabilizer, which therefore represents an element of weight

increase compared to the box-wing; *iii*) the box-wing has two additional aerodynamic surfaces, i.e. the vertical tip-wings, which are therefore a source of weight increase. The overall effect of these contributions is a reduction in the structural mass of the lifting system for box-wing configurations, as depicted in Figure 20, where m_w is the mass of the lifting system and OEW is the operating empty weight. The occurrence of a less severe loading condition and the integration of lifting, stability and trim functions in a single component introduce structural advantages that outweigh the penalty due to the presence of the tip-wings.

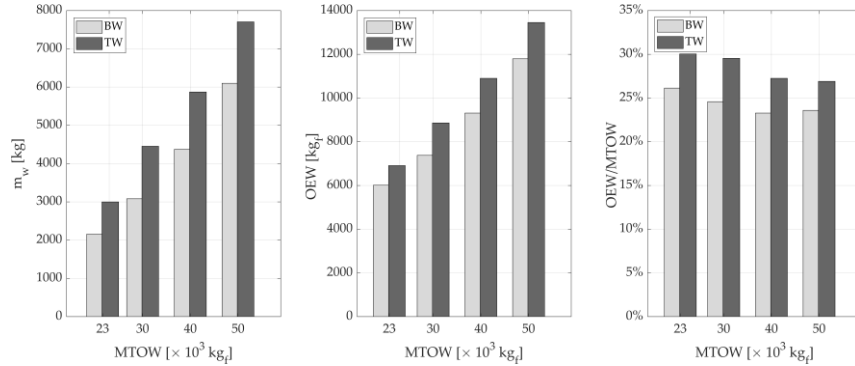

Figure 20. Lifting system mass and operating empty weight comparison. Image adapted from [82]

The lower structural mass share, therefore, for a fixed MTOW allows to transport a larger mass of batteries, that is fundamental to optimize the performance of the hybrid-electric aircraft in terms of block fuel. Box-wing configurations, as detailed in ref. [82], also introduce improvements in terms of lift-to-drag ratio and propulsive efficiency, however the greatest impact on fuel consumption is due to the larger mass of the battery that can be transported. Figure 21 shows the block fuel maps within the payload-range diagrams of the hybrid-electric configurations examined. A significant aspect of this performance analysis is that all box-wing configurations are capable of achieving lower fuel consumption than the corresponding tube-and-wing across the entire operating envelope.

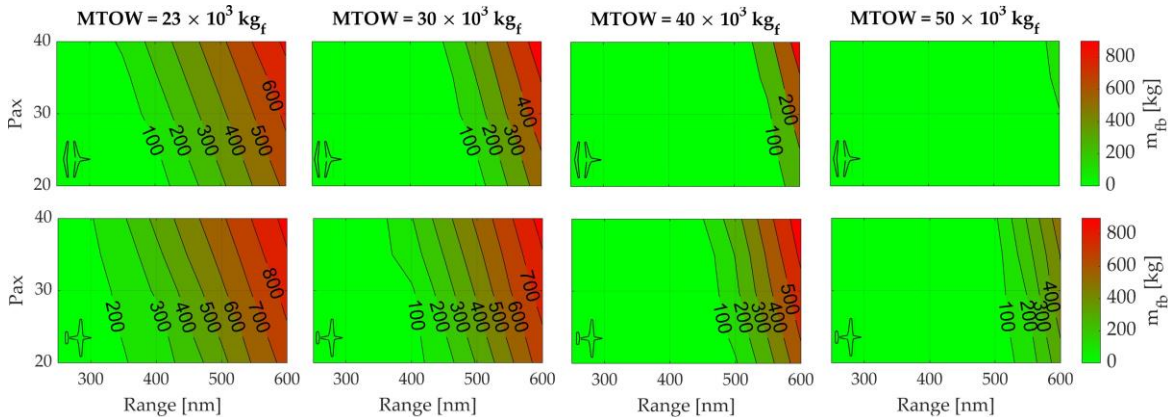

Figure 21. Block fuel maps in the pax-range diagram for the regional box-wing and tube-and-wing varying MTOW. Image adapted from [82]

These promising results in terms of mission performance paved the way for the subsequent more general investigation of the impact that regional box-wings could have considering other figures of merit. In particular, the conceptual analysis proposed in ref. [83] highlights that the performance advantages of the box-wing also lead to reductions in CO₂ emissions and reductions in direct operating costs compared to tube-and-wing counterparts. Finally, evaluating the effects in terms of compatibility with the airport infrastructure, in ref. [83] it is observed that the ability of the box-wing to distribute the trim lift on two distinct lifting surfaces allows considerable reductions in the wingspan b compared to the tube-and-wing, see Figure 22.

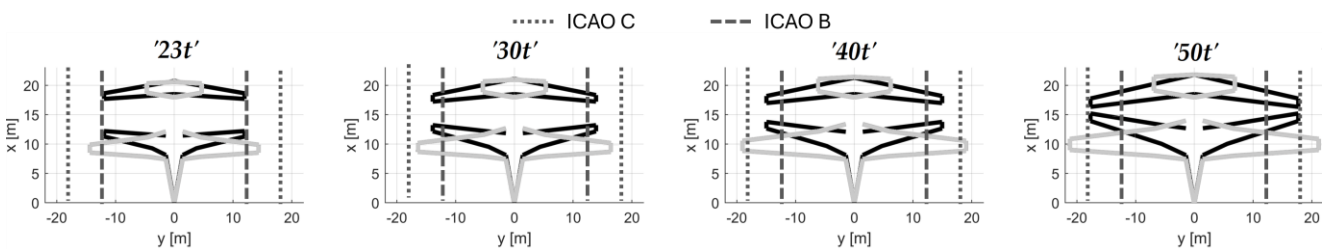

Figure 22. Planform comparison of optimized hybrid-electric configurations; image taken from [83]

This feature allows the box-wing configuration to be compatible with the ICAO 'B' standard ($b < 24$ m) in the case of the '23t' configuration (MTOW=23 tons), and to always be compatible with the ICAO 'C' standard ($b < 36$ m) for the other MTOW categories. On the other hand, the tube-and-wing configuration is never compatible with the 'B' standard, and the 40 and 50 tons configurations are not even compatible with the 'C' standard, resulting in serious operating penalties due to the reduced number of airport aprons available for the 'D' standard (usually also dedicated to long-haul transport only). This aspect of compatibility with aprons is of paramount importance in the regional market, where short routes are often operated between locations with modest airport infrastructure [81]. In addition, remaining in the context of ground performance, the study proposed in ref. [84] evaluated the take-off performance of the regional hybrid-electric tube-and-wing and box-wing configurations. In this regard, indeed, there are many features that differ between the two architectures; first, for the box-wing the position of the front wing, located very close to the ground (see Figure 23), is much more sensitive to ground effect, giving the lifting system general aerodynamic advantages in terms of lift and drag during the take-off run. Secondly, the geometry of the lifting system has a significant influence on the aeromechanical behaviour: the arrangement of the wings in the horizontal plane and the layout of the movable surfaces and flaps introduce substantial differences in pitch dynamics (see ref. [13]). A three-degree-of-freedom take-off dynamics simulator was therefore developed to simulate the manoeuvre for aircraft of any architecture; the simulator is able to take into account the ground effect on the aerodynamic and aeromechanical characteristics of the aircraft at each instant of the manoeuvre, as accurately detailed in ref. [84]. The results of the simulations show that the geometric, aerodynamic and aeromechanical characteristics of the box-wing also allow to obtain non-negligible reductions in terms of runway length.

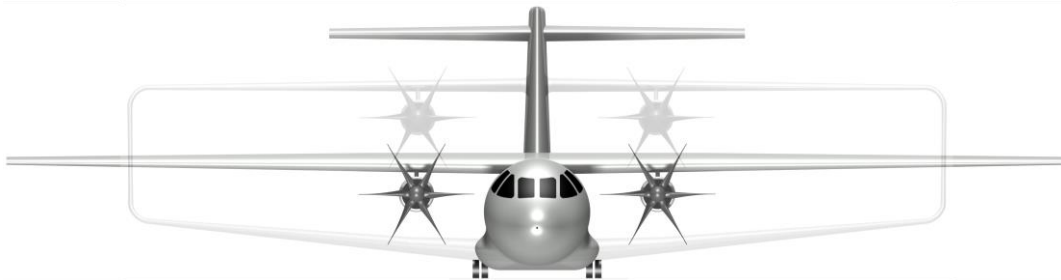

Figure 23. Front view comparison of tube-and-wing and box-wing regional configurations

3.3 General aviation aircraft

Disruptive technological innovation in aeronautics usually has a bottom-up development, i.e. it involves integration, testing, and validation in contexts related to small aircraft before application to large transport aircraft. Following this perspective, it was developed the study presented in ref. [85], that provided the conversion of the lifting architecture of an existing aircraft to the box-wing one, to evaluate its potential performance and functional benefits at a conceptual level. This study involved the evaluation of the impact of the introduction of the Best Wing System on the Piaggio P180 Avanti II aircraft [86], whose three-planes view is shown in Figure 24-right. This design choice had been anticipated in ref. [7], which offered advantages that would hypothetically be obtained by converting the P180 to the box-wing configuration. In particular, the potential benefits envisaged are: *i*) the increase of the lift-to-drag ratio, and therefore a consequent reduction in fuel consumption; *ii*) the removal of the fuselage wing-crossing in the aft area: this allows the cabin to have a larger internal volume available to take on board payload, but also to enable the lengthening of the fuselage while keeping the overall dimensions of the aircraft unchanged (see Figure 24); *iii*) the lifting system can be designed with proper sweep angles, favouring the installation of turbofan engines to enable transonic cruise flight; moreover, the replacement of the very noisy pusher propeller engines could lead to a reduction in noise emissions; *iv*) the proper design of the lifting surfaces of the box-wing could lead to an improvement in stall performance. These drivers therefore represent the *basic requirement* guiding the conceptual development of this box-wing.

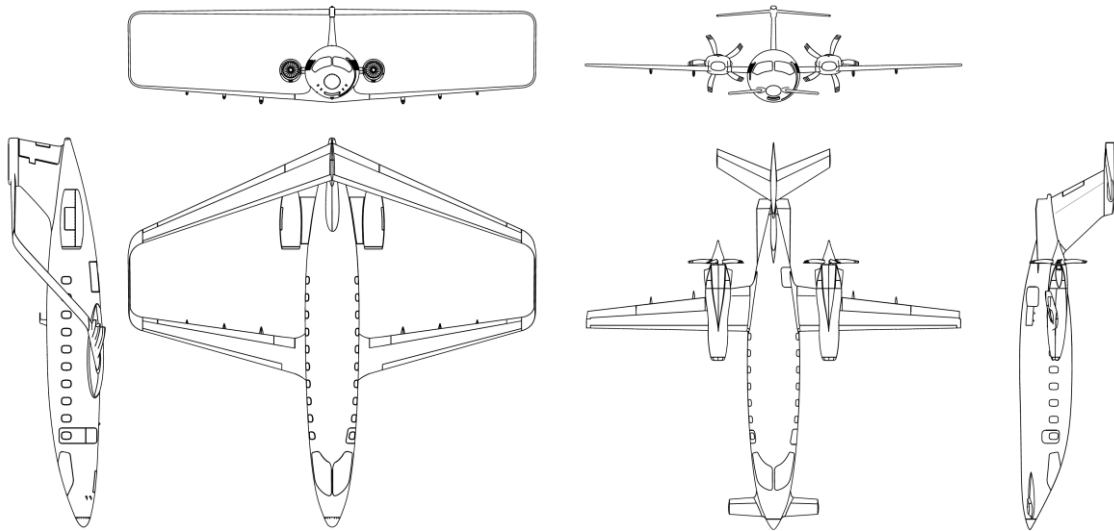

Figure 24. Three planes view of Piaggio P180 (right) and its box-wing version (left)

To test some of the hypotheses supposed in ref. [7], a conceptual design procedure based on the tools described in ref. [37] was employed in the study in ref. [85]. In particular, numerous box-wing lifting configurations have been sized using the aerodynamic optimization procedure already described in Section 3.1.1. This procedure made it possible to identify performance trends and to evaluate the possible aerodynamic differences between the P180 and its box-wing version. In order to identify configurations that can be used in the same hangars as the P180 and in the same maintenance centres, the same general dimensions have been set for both configurations, namely: wingspan equal to 14.03 m and overall length equal to 14.4 m. Since the removal of the wing-fuselage crossing, made possible by the low front wing of the box-wing architecture (see Figure 24-left) increases the volume available in the cabin, four additional seats can be installed compared to the P180, thus increasing from 7 to 11 passengers in air taxi configuration. A modification of the aft area of the fuselage must still be carried out, introducing differences in the estimates of the fuselage drag coefficient. In addition, this reconfiguration introduces an update of the maximum take-off weight. Conceptually, the integration of the box-wing lifting system in this case is analogous to that discussed for the medium-haul aircraft (see Section 3.1), namely: to exploit the greater lifting capacities of the box-wing to trim a larger design weight, and thus increase the payload; to maximize the lift-to-drag ratio to improve flight efficiency and reduce fuel consumption per passenger; to maintain the same size as the direct competitor, to enable effective integration into the ground infrastructure currently used. The results of the conceptual sizing procedure presented in ref. [85] highlight the high lift-to-drag ratio of the box-wing system; in particular, it is clear that the greatest advantage is obtained with aircraft that, for the same size, have higher weights. This is due to the fact that the increase in lift needed to trim heavier aircraft is associated with a very small increase in induced drag. In general, box-wing configurations show an increase in L/D compared to the reference competitor, evaluated with the same calculation methods. On the other hand, the expectations on the best stall performance have been assumed on the basis of the theoretical and experimental results obtained in the development of the ultralight box-wing aircraft, as will be detailed in Section 3.4.

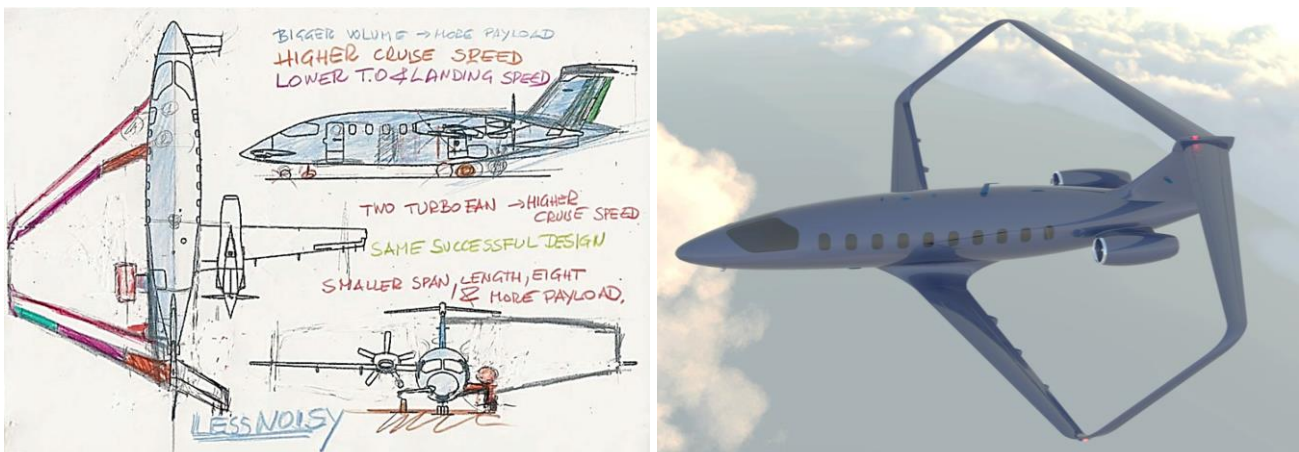

Figure 25. Initial conceptualization (left) [7] and artistic rendering (right) [87] of the box-wing version of the Piaggio P180

Figure 25-left shows the initial conception of the idea, as reported in ref. [7], while Figure 25-right depicts the rendering of the final result of a possible finalization of the design development. In the middle are the feasibility and conceptual studies proposed in ref. [85], which represent the starting point of a research and development path that still needs huge efforts and investments in order to achieve practical application results. Such efforts, on the other hand, were instead provided for the development of an ultralight box-wing aircraft, which despite its complexity, represented the simplest platform in which to increase the level of maturity of this lifting system, as described in Section 3.4.

3.4 Ultralight amphibian aircraft

The IDINTOS project was an impressive research and development platform for the box-wing configuration [88]. The target of the project, an amphibious seaplane, had the best size features to enable detailed studies to be carried out without the need for excessive costs or large infrastructures. Therefore, the *basic requirements* that directed the development of this aircraft have two different origins; on the one hand, the box-wing configuration is introduced to improve aerodynamic performance in different phases of flight, as decrease fuel consumption or increase the distances that can be covered, and improve low-speed manoeuvrability and stall stability characteristics, thus increasing flight safety. On the other hand, the project was used as a scientific platform to test and verify up to the experimental level the theoretical hypotheses on the characteristics of the box-wing, both in aerodynamic terms and in respect of flight mechanics and structures. The project development, therefore, covered all the typical phases of aeronautical design, from the initial conceptual phase, through a high-fidelity preliminary verification, to experimental characterisation; finally, the project demonstrated its feasibility through the manufacturing and assembly of a full-scale technological demonstrator (see Figure 26-right).



Figure 26. IDINTOS ultralight amphibious aircraft

The design process, outlined in its main aspects in ref. [88], has been initialised with the definition of the main requirements, such as: a number of two side-by-side seats; cruise speed equal to 230 km/h; minimum stall speed equal to 65 km/h; maximum take-off weight not exceeding the limit set by the ultralight regulations; wingspan equal to 8 m. The aerodynamic design is initialised in its conceptual phase by means of an aerodynamic optimisation procedure, using the AEROSTATE code, as also described in the case of the medium-haul and general aviation box-wing. The optimisation is aimed at maximising the lift-to-drag ratio in cruise condition, and it is constrained to respect static stability and controllability in the longitudinal plane (stability and control derivatives are calculated using a VLM solver, see Figure 27-left). The process was highly iterative and led to an evolution of the geometry of the lifting system, as depicted in Figure 27-right.

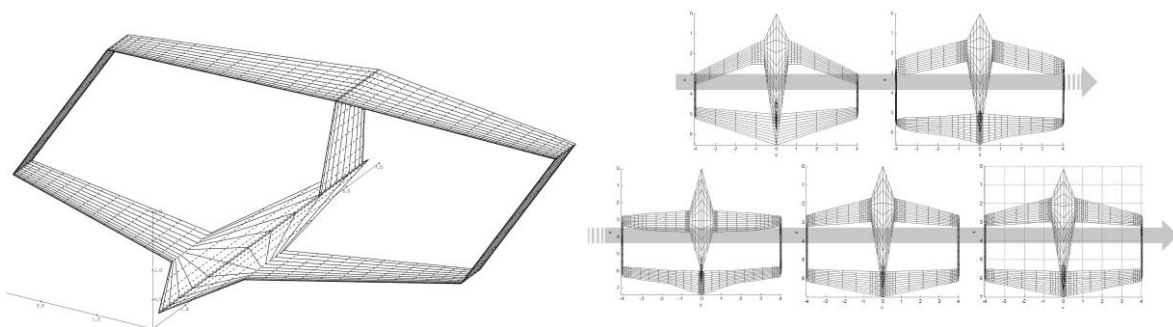

Figure 27. VLM representation of the IDINTOS aircraft

A fundamental role in the subsequent aerodynamic development of the IDINTOS aircraft was played by an extensive CFD RANS numerical simulation campaign, described in refs. [89] and by the following experimental assessment campaign carried out in the wind tunnel. These activities served to validate the performance trends predicted in the conceptual phases of the project, to characterise the aerodynamic performance of the configuration, and to evaluate its main aeromechanical characteristics (preliminary assessment are discussed in ref. [90]). Considering the high-speed phases, i.e. those related to cruise flight, CFD analyses proved the validity of the VLM estimates in terms of C_L - α and C_M - α curves (error <5%) as well as providing a more accurate estimate of lift-to-drag-ratio [88]. A further campaign of CFD simulations for the low-speed phases was performed with the aim of sizing the high-lift systems, and afterwards evaluating the stall performance. The process of flap sizing, documented in ref. [91], led to a solution with fowler flaps on the front wing and plain flaps on the rear wing; with this configuration, the constraint on stall speed imposed by ultralight regulations was verified. Finally, a further campaign of CFD simulations was carried out to evaluate and define different configurations of the hull of the amphibious aircraft, and preliminarily assess its performance and take-off dynamics. The high and low speed performances are commented below together with the results obtained in the experimental assessment phase.

The experimental campaigns involved three different aspects, which will be commented on in the following: *i)* the wind-tunnel aerodynamic characterisation in high and low speed; *ii)* the analysis of the dynamic behaviour of the hull during take-off by means of tests in a water tank; *iii)* the preliminary assessment of the flight dynamic characteristics by means of flight testing on a dynamically scaled flying model. Wind tunnel tests were carried out on a $\frac{1}{4}$ scaled model (Figure 28-left) fitted with movable surfaces and high-lift systems; several test campaigns were carried out (see refs. [89,92]) to assess the goodness of the theoretical predictions on the aerodynamics of the Best Wing System, to evaluate aerodynamic performance in cruise phase, to study stall behaviour at low speed considering flaps deployment, and to validate the estimations made via numerical simulations. The verification of the BWS theory was carried out by testing the model under the same operating conditions but in two different configurations: a pure biplane, obtained by removing the vertical tip-wings, and the original box-wing configuration. The results, proposed in Figure 28-right, show that considering a range of C_L typical of the aircraft operating scenario, the box-wing introduces drag reductions between 6% and 10%, in good agreement with the theoretical prediction.

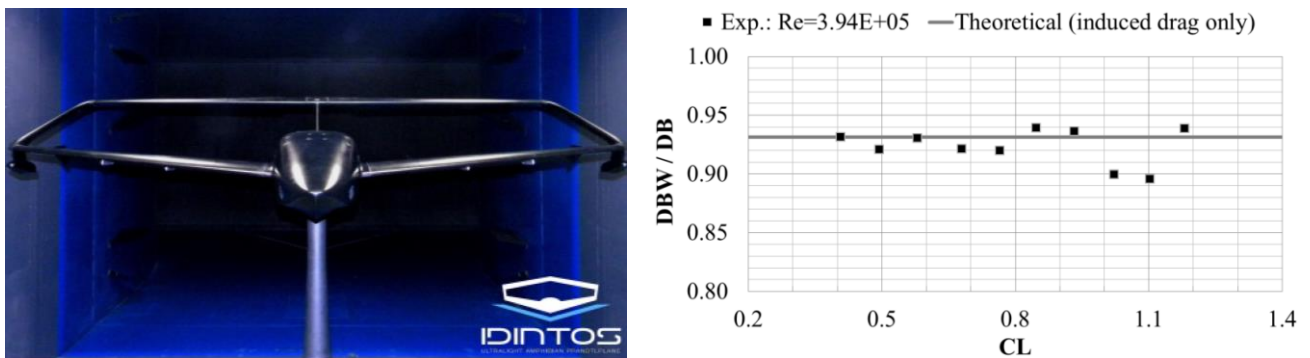

Figure 28. Wind tunnel test model (left) and results (right); DBW and DB are the drag of the box-wing and of the biplane model, respectively

The aerodynamic performance in cruise was then evaluated in terms of C_L - C_D , C_L - α , and C_M - α curves. The aerodynamic polar, Figure 29-left, shows the experimental findings for the amphibious box-wing aircraft developed in IDINTOS; specifically, it exhibits a maximum lift-to-drag ratio of 16.3 given around; this value is high for an aircraft whose fuselage is actually a hull. On the other hand, the C_L - α (Figure 29-centre) and C_M - α (Figure 29-right) curves highlight the very smooth stall behaviour of the box-wing: in fact, it is observed that, when the lift begins to lose linearity (around $\alpha=10^\circ$), the moment coefficient is pitching down with a larger slope, thus tending to provide a pitch behaviour that acts as a stall recovery. This is mainly due to the fact that at high angles of attack the front wing experiences flow separation, and the rear wing still generates lift which increases the pitching moment. The smoothness of the stall can also be observed from the C_L plateau, which does not show sudden and severe drops.

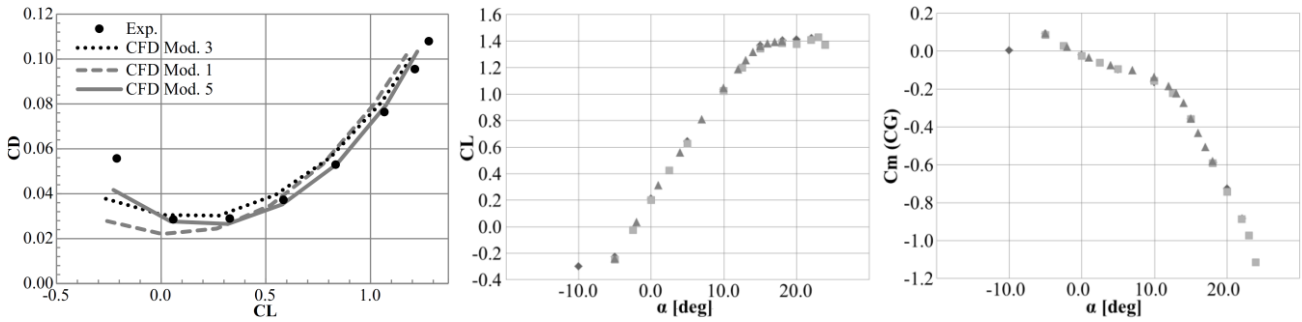

Figure 29. Experimental results: drag polar curve (left), lift coefficient curve (centre), pitch moment coefficient curve (right)

It was even more interesting to analyse the stall behaviour at low speed, which is the most critical for flight safety, when the flaps are deployed. Figure 30 shows the C_L - α curve (see ref. [88]) in which a large lift plateau after the stall is also observed in the flapped case, showing effective smoothness under critical conditions. Other tests were carried out to verify that the precision of pitch manoeuvres can be increased by using two counter-rotating elevators, placed on the front and rear wings, which can generate pure pitch without perturbing the lift; the results showed that by properly calibrating the elevator deflections it is possible to manoeuvre in pitch with negligible impact on the lift variations, increasing safety in the case of critical manoeuvres near the ground (e.g. aborted landing).

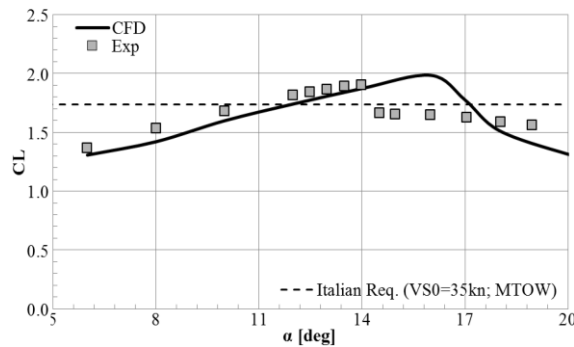

Figure 30. Experimental curve for C_L - α in flapped condition

A parallel experimental campaign was carried out in the water tank, with the aim of defining the final geometry of the hull (see design parameters available in Figure 31-left) and evaluating its dynamic characteristics during the complex take-off manoeuvre from the water. A 1/3-scaled model of the hull was properly instrumented and mounted on the test rig in the naval tank (Figure 31-right). Specifically, actuators simulating the forces introduced by the propellers, springs simulating the pitch stiffness $Cm\alpha$, dampers simulating the $Cm\dot{\alpha}$, and lift-relief systems were calibrated and installed on the model to simulate real-time changes in aeromechanical parameters during the take-off run. Hundreds of tests were carried out to study the hull dynamics in the different phases of the manoeuvre, such as the displacement and planing phases, to evaluate the hydrodynamic drag during the take-off run, and to characterise the dynamic behaviour of the hull, in order to study the instability phenomenon known as porpoising, and to make the most suitable design choices to avoid it. More details are available in refs. [88,93].

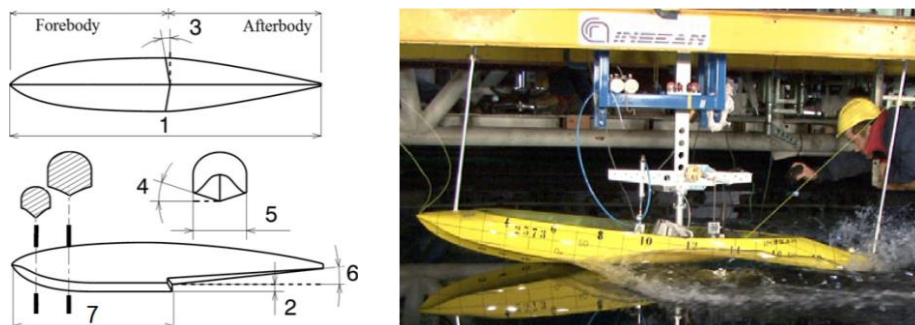

Figure 31. Hull geometry (left) and scaled model during water tank testing (right)

Finally, a last experimental campaign was focused on the study of the aircraft's dynamics in different flight conditions, by means of flight tests on a radio-controlled scaled model. The sub-scaled model was built using the rules of dynamic scaling [94]; in particular, the model is in 1/4 scale of the real

aircraft, and has a wingspan of 2 m, a wing surface of 0.88 m², and a mass of 9 kg; images of the dynamically scaled amphibious box-wing aircraft model set on the ground, in water, and in flight, are shown in Figure 32; more details are in ref [88]. Preliminary flight tests have produced very interesting results, especially regarding the stall and manoeuvrability. A stall speed of 32 km/h was measured at an incidence of $\alpha=14^\circ$, at which a C_{Lmax} of 2.3 was estimated. Qualitative tests demonstrated the longitudinal stability and good manoeuvrability of the aircraft throughout the investigated operating envelope. Further preliminary tests were carried out by taking-off and landing on water surfaces, to evaluate the dynamic response in the complex phases of acceleration and deceleration in the seaplane mode. Further more detailed flight tests on this scaled model are planned in the near future.



Figure 32. Scaled flying model in ground (left), in water (centre), and in flight (right)

Also from the structural point of view, the design of the main structures of the lifting system was carried out with a multi-fidelity approach, as schematised in Figure 33. Initial assessments were carried out by means of stick models, which were simplified but effective in providing information in the early stages of the design, see ref. [95]. Subsequently, more accurate assessments and detailed constructive solutions were carried out by means of Finite Element Method (FEM) numerical simulations. Finally, the most promising structural solutions were prototyped to verify the easiness of manufacturing and assembly (see ref. [96]), and to make a real estimation of the economic effort required.

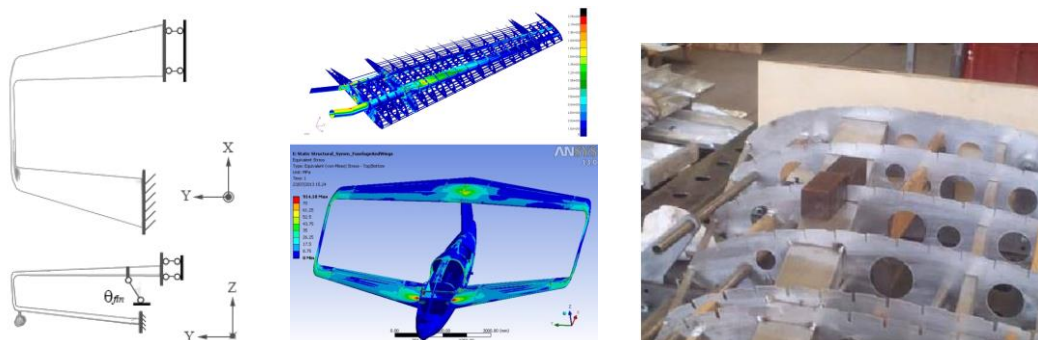

Figure 33. Stick model (left), finite element model (centre), and built prototype (right) of IDINTOS wings

All in all, with the manufacture and assembly of the full-scale version of the technological demonstrator prototype, depicted in Figure 34, the IDINTOS project demonstrated that a bottom-up design path integrating aeronautical innovation applied to small aircraft is feasible and leads to significant scientific-technological advancements. The designed aircraft not only represents a disruptive step in its sector, that of ultralights, but has represented a real laboratory for testing and experimentation to obtain technical indications that can be exploited for aircraft of other categories and larger sizes. This approach, if replicated in incremental scales of aircraft size, could be the least risky and most valuable in integrating a new disruptive configuration into the transport aviation industry.



Figure 34. IDINTOS full scale demonstrator and its flying scaled model

3.5 Freighter

Another application case of the box-wing configuration is that of the very large cargo aircraft. Some preliminary studies investigated box-wing effectiveness within a context, that of air freight transport, which is very different from that of passenger transport and strongly constrained by ground infrastructure. In this case, the *basic requirement* partially follows the one discussed in Section 3.1 regarding the medium-range aircraft; as widely discussed in ref. [97], in fact, also in this case it was exploited the box-wing concept to increase the payload weight to be transported. However, in this case, the payload capacity is extremised towards the maximum limits and compatibly with airport constraints, therefore the wingspan of the aircraft has been set at the maximum possible, i.e. equal to 80 meters. This would allow to design and optimize the box-wing lifting system with the highest possible lifting capacity, and therefore probably the possibility of transporting as much cargo as possible with a single aircraft. This design driver has been extensively discussed at the conceptual level in refs. [97-99]. Relevant insights, in addition to the design and optimization of the lifting system (see ref. [100]), and the integration of the propulsion system [97], have mainly concerned the design of the fuselage, which is essential for the proper storage of the huge number of cargo containers to be transported, see ref. [101]. Figure 35 shows an artistic representation of the box-wing freighter. The studies on the development of a very large box-wing aircraft capable of carrying the maximum possible payload were also accompanied by detailed studies on the infrastructural scenario of the cargo traffic sector and the related network of available airport facilities; this is essential to calibrate the requirements and size the best possible vehicle that can integrate cost-efficiently into this scenario. Details of these studies are given in refs. [97,102]. The combined aircraft design and airfreight system optimization is therefore aimed at identifying the most cost-effective space to improve air cargo traffic, which especially in recent years has been growing substantially. These studies have stopped at the conceptual level, but have nevertheless shown that even such an application of the box-wing configuration could introduce substantial advantages in an area that is currently technologically underdeveloped, such as air freight.

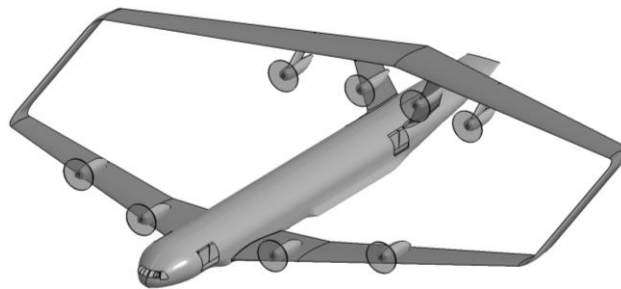

Figure 35. Artistic representation of the box-wing very large freighter. Image adapted from [97]

3.6 Urban Air Mobility

A very interesting and much studied application of electric propulsion for transport aircraft is that of the emerging Urban Air Mobility (UAM) sector [103]. This sector involves the development of small air transport units capable of acting as air-taxis in very large metropolitan areas. Currently, studies and developments on ground infrastructure and most suitable aircraft for this market are flourishing and booming [104]. The peculiar feature that UAM aircraft must have, in addition to electric propulsion, is that they can take-off and land vertically, thus allowing easy mobility within urban contexts, where it is not possible to have several small airports; these aircraft are therefore called electric Vertical Take-Off and Landing (eVTOL). Different architectures were investigated to meet this requirement, such as multirotors, tiltrotor, and lift-and-cruise, see refs. [105]. On the other hand, the box-wing configuration can be exploited in the tiltwing category, i.e. the one in which an aircraft is designed having the wings that can rotate, and the engines jointly with them. This feature would allow the eVTOL to be efficient both in the take-off, landing and hovering phases, having a behavior similar to that of a multirotor, and in the cruise phase, having the aerodynamic performance typical of a fixed-wing aircraft (box-wing in this case). A conceptual study on this application has been proposed in ref. [106], where a box-wing aircraft with tiltwing features, called *TiltOne*, has been designed to perform different missions in the context of the UAM scenario, with a number of seats equal to 4 and a flight distance varying between 7 and 50 nm; an artistic sketch of this concept, in the fixed wing and multirotor configurations, is proposed in Figure 36. The study proposed in ref. [106] offers design ideas at the conceptual level, and an extensive performance analysis for different operating requirements (e.g. flight distance, or

number of repeated flights without charging batteries), considering different levels of battery technological readiness. The results show that conceptually such a machine would be adequate to effectively cover a wide range of operating scenarios in the UAM sector, and thus paves the way for more refined detailed studies.

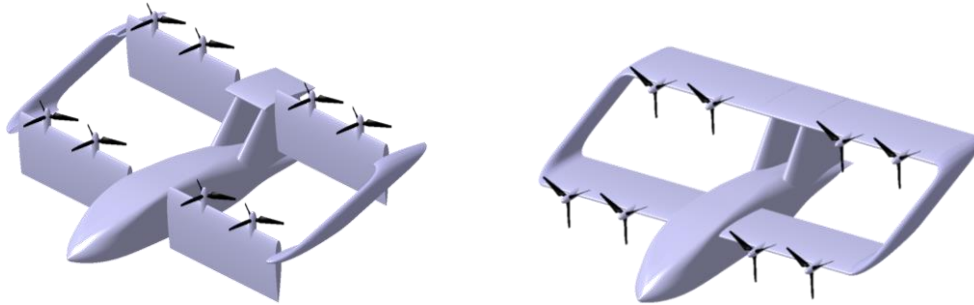

Figure 36. Box-wing tiltwing in multirotor (left) and fixed-wing (right) layouts. Image taken from [106]

In particular, the main problem to be studied in depth before a possible integration into an industrial design path lies in its safety and reliability. In this regard, the most critical aspect is that of the transition from multicopter to fixed-wing aircraft, in which the dynamic behaviour of the aircraft is highly uncertain and variable, and require effectively robust control systems [107]. In order to evaluate these aspects in the initial phase of the development of such a complex machine, in parallel with the conceptual studies proposed in ref. [106], experimental studies are being developed on scaled flying models reproducing the characteristics of the *TiltOne*. Given the strong uncertainty about the control characteristics in the transition phase, these models are manufactured in a simplified way, but still having a dynamic behaviour attributable to that of the full-scale aircraft, so as to be able to carry out a large number of tests while keeping costs low; a representation of one of the models developed and used in the testing phase is shown in Figure 37. The design development of the scaled models, together with the first preparatory activities related to the flight testing campaign is described in refs. [108,109]; the experimental campaign is still ongoing, and at the moment no results are yet available in the literature.

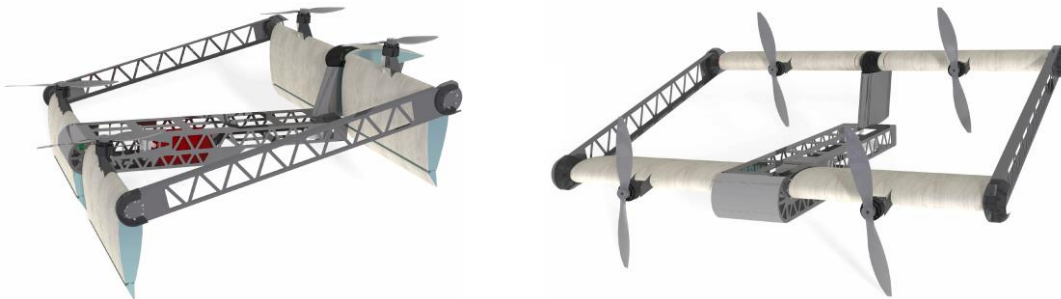

Figure 37. Experimental scaled model of the box-wing eVTOL. Image adapted from [108]

4. Limitations

The scenario outlined above offered interesting insights into the potential of applying the box-wing configuration to different categories of aircraft. In particular, by overturning the classical evolutionary approach, which could introduce limited and barely consistent advantages to the current scenario, a breakthrough approach could open up specific functional and performance scenarios for such innovation. It has therefore been noted that, even at levels of conceptual or demonstrative integration, there is a substantial terrain in which the introduction of the box-wing concept can introduce significant advantages, potentially not obtainable with the incremental development of the consolidated tube-and-wing configuration. On the other hand, it seems that these analyses stop at a level *'on the paper'* and that they have not served as a driving force to start a broader development program, aimed at some form of experimental industrial integration. What could be the reasons that are leading to this condition of plateauing in the development of such a concept? We have indicated qualitatively some of them below, according to the authors' judgment, premising that it is well known that the civil aeronautical industry is a complex and articulated structure, and that introducing radical innovations in such a complicated system involves risks of massive scale.

A first technical problem lies in the need to undertake an incremental path of the level of knowledge

and technological maturity of the concept analysed. In the case of the box-wing, this maturity is partial but coherent as far as the aerodynamic characterization is concerned, but there are still numerous knowledge gaps in the structural design, the integration of the main structures in a manufacturing and assembly context, and a solid characterization from the aeroelastic point of view. While from the point of view of a small aircraft such limitations are easily overcome, as demonstrated by the IDINTOS project, they become the main cornerstone of the development of a large transport aircraft. However, a structural and aeroelastic characterization with an adequate level of technological readiness for an unconventional concept such as the box-wing requires significant and targeted investments; conceptual studies, therefore, would serve as an initial driving source to encourage industrial interest in investing resources, even substantial ones, in the experimentation and development of this concept. The description of aeroelastic behaviour is definitely very uncertain at a conceptual stage of development, and therefore it is the one that contributes the most to a certain reluctance to investigate at higher fidelity and at a higher cost. Starting from small aircraft, which have a much lower aeroelastic structural complexity than airliners, could be the right approach to build step by step the road towards a sound interchange between basic research and industrial integration; In this path, the main piece is currently missing, the one that would lead an ultralight box-wing configuration (such as IDINTOS) to a demonstration full-scale flight test campaign.

Secondly, the impact that the integration of the box-wing at an industrial level could have on the consolidated manufacturing and assembly processes has never been addressed in a sufficiently rigorous and reliable way. Although the concept of box-wing does not introduce the need to produce and assemble components that are totally different from those of tube-and-wing aircraft (which is not the case of totally radical configurations, such as blended-wing-body), it is still necessary to clarify the impact that this can have on production chains and on the use of current assembly lines. To comply with established manufacturing processes, and their efficiency and maturity, is a key point for the successful development of a complex product such as a novel transport aircraft.

Finally, certification must be carefully considered from the very early stages of the development of an aircraft with potentially different operating characteristics with respect to the established practices. Undoubtedly, when introducing disruptive technologies and configurations in the field of transport aviation, the certification aspects (and the associated costs) represent the main obstacle and challenge, and must be addressed from the very beginning of the design development; Some methods and comments on the issue are proposed in refs. [110,111].

One of the roles of basic research is to try to prove the goodness of an idea at a conceptual level, and to show its potential and possible critical issues, in an initial step of a much broader process of development and industrial integration. The box-wing seems to have passed this initial test, but now it is necessary to increase the detail of the level of technical investigation, and therefore its *Technology Readiness Level* (TRL). The development curve, especially for extremely complex products such as transport aircraft can only grow with increasing investments and deepest studies and experimentation.

5. Conclusion

This article has proposed a general review of the possible applications of the box-wing configuration to different categories of transport aircraft. The comment and the discussion of this review aimed to highlight the peculiarities of the box-wing configuration, which could theoretically introduce performance and functional benefits compared to the state of the art. The possible ways in which radical innovations can be developed into the aeronautical frame have been preliminarily commented, showing that breakthrough innovations may require different design development paths than those of conventional aircraft. In particular, providing applications specifically tailored to the performance and functional characteristics of the specific innovation considered, the box-wing in this case, is a key aspect to contribute to its effective development. By following this approach, in the literature the box-wing configuration has been applied to categories of aircraft having different requirements, features, and objectives, such as: medium-haul transport, regional (hybrid-electric), general aviation, amphibious ultralight, freighter, urban air mobility. For each category, several studies have applied the box-wing concept trying to extract its maximum performance and functional potential. The commented analyses were carried out following multidisciplinary and holistic

approaches, highlighting through a complete overview the operating potential of the configuration. For each category, the box-wing configuration seems to offer peculiar advantages, which would enable a step forward compared to the incremental development of the currently consolidated configuration, the tube-and-wing. However, the actual introduction of such a radical innovation in the transport aviation sector is not simple and requires increasingly accurate and detailed investigations. In addition, specific problems related to the certification and assembly procedures may represent showstoppers to the effective integration of the concept.

Copyright Statement

The authors confirm that they, and/or their company or organization, hold copyright on all of the original material included in this paper. The authors also confirm that they have obtained permission, from the copyright holder of any third party material included in this paper, to publish it as part of their paper. The authors confirm that they give permission, or have obtained permission from the copyright holder of this paper, for the publication and distribution of this paper as part of the ICAS proceedings or as individual off-prints from the proceedings.

References

1. McMasters J. H., Paisley D. J., Hubert R. J., Kroo, I., et al., "Advanced configurations for very large subsonic Transport Airplanes," NASA CR 198351, 1996, available at: <https://ntrs.nasa.gov/citations/19970003675>
2. Bravo-Mosquera P. D., Catalano F. M., Zingg, D. W., "Unconventional aircraft for civil aviation: A review of concepts and design methodologies," *Progress in Aerospace Sciences*, 131, 100813, 2022, <https://doi.org/10.1016/j.paerosci.2022.100813>
3. Prandtl, L., "Induced Drag of Multiplanes," *Technical Note, NACA TN-182*, 1924, <https://ntrs.nasa.gov/citations/19930080964>
4. Frediani A., Montanari G., "Best wing system: an exact solution of the Prandtl's problem," *Variational Analysis and Aerospace Engineering*, Springer Optimization and Its Applications, vol. 33, 2009, doi: 10.1007/978-0-387-95857-6_11
5. Frediani A., "The PrandtlWing," *VKI, Lecture Series: Innovative Configurations and Advanced Concepts for Future Civil Transport Aircraft*, 2005, available online: <https://perma.cc/XU6F-8YLG>
6. Cavallaro R., Demasi L., "Challenges, Ideas, and Innovations of Joined-Wing Configurations: A Concept from the Past, an Opportunity for the Future," *Progress in Aerospace Sciences*, vol. 87, 2016, doi: 10.1016/j.paerosci.2016.07.002
7. Frediani A., Cipolla V., Rizzo E., "The PrandtlPlane Configuration: Overview on Possible Applications to Civil Aviation," *Variational Analysis and Aerospace Engineering: Mathematical Challenges for Aerospace Design*, vol. 66, Springer, 2012, https://doi.org/10.1007/978-1-4614-2435-2_8
8. Picchi Scardaoni, M., "A Simple Model for Minimum Induced Drag of Multiplanes: Could Prandtl Do the Same?," *Aerotecnica Missili & Spazio*, 99, 233–249, 2020, <https://doi.org/10.1007/s42496-020-00058-y>
9. Demasi L., Dipace A., Monegato G., Cavallaro R., "Invariant formulation for the minimum induced drag conditions of nonplanar wing systems," *AIAA journal*, vol. 52(10), pp. 2223-2240, 2014, <https://doi.org/10.2514/1.J052837>
10. Demasi L., Monegato G., Dipace A., Cavallaro R., "Minimum Induced Drag Theorems for Joined Wings, Closed Systems, and Generic Biwings: Theory," *Journal of Optimization Theory and Applications*, 169, 200–235, 2016, <https://doi.org/10.1007/s10957-015-0849-y>
11. Demasi L., Monegato G., Rizzo E., Cavallaro R., Dipace A., "Minimum Induced Drag Theorems for Joined Wings, Closed Systems, and Generic Biwings: Applications," *Journal of Optimization Theory and Applications*, 169, 236–261, 2016, <https://doi.org/10.1007/s10957-015-0850-5>
12. Demasi L., Monegato G., Cavallaro R., "Minimum induced drag theorems for multiwing systems," *AIAA Journal*, 55(10), 3266-3287, 2017, <https://doi.org/10.2514/1.J055652>
13. Abu Salem, K., Palaia, G., Quarta, A.A., Chiarelli, M.R., "Preliminary Analysis of the Stability and Controllability of a Box-Wing Aircraft Configuration," *Aerospace*, 10, 874, 2023, <https://doi.org/10.3390/aerospace10100874>
14. Munk M., "General biplane theory," *Technical Report, NACA-TR-151*, 1923, <https://ntrs.nasa.gov/citations/19930091216>
15. Howe, D., *Aircraft conceptual design synthesis*, London, UK: Professional Engineering Publishing, 2000, ISBN:9781118903094
16. Adler, E. J., Martins, J. R., "Hydrogen-powered aircraft: Fundamental concepts, key technologies, and environmental impacts," *Progress in Aerospace Sciences*, 141, 100922, <https://doi.org/10.1016/j.paerosci.2023.100922>
17. Schiktanz D., Scholz D., "Box Wing Fundamentals - An Aircraft Design Perspective," *DGLR: Deutscher Luft- und Raumfahrtkongress, DLRK*, Bremen, Germany, 2011, Download: <http://Airport2030.ProfScholz.de>
18. Roy Salam, I., Bil, C., "Multi-disciplinary analysis and optimisation methodology for conceptual design of a box-wing aircraft," *The Aeronautical Journal*, 120(1230), 1315-1333, 2016, <https://doi.org/10.1017/aer.2016.59>
19. Andrews S. A., Perez, R. E., "Comparison of box-wing and conventional aircraft mission performance using multidisciplinary analysis and optimization," *Aerospace Science and Technology*, 79, 336-351, 2018, <https://doi.org/10.1016/j.ast.2018.05.060>
20. Abu Salem, K., Palaia, G., Carrera, E., "A discussion on benchmarking unconventional configurations with conventional aircraft: the box-wing study case", 2024, *submitted*
21. Abu Salem, K., Binante, V., Cipolla, V., Maganzi, M., "PARSIFAL Project: a Breakthrough Innovation in Air Transport," *Aerotecnica Missili & Spazio*, 97, 40–46, 2018, <https://doi.org/10.1007/BF03404764>

22. Airbus, *Global Market Forecast, 2023*, available online at: <https://www.airbus.com/en/products-services/commercial-aircraft/market/global-market-forecast>
23. Eurocontrol, *European Aviation in 2040, Challenges of Growth*, 2018, available online: <https://perma.cc/2A2J-B7PW>
24. Platzer, M. F., "A perspective on the urgency for green aviation," *Progress in Aerospace Sciences*, 141, 100932, 2023, <https://doi.org/10.1016/j.paerosci.2023.100932>
25. Ficca, A., Marulo, F., Sollo, A., "An open thinking for a vision on sustainable green aviation," *Progress in Aerospace Sciences*, 141, 100928, 2023, <https://doi.org/10.1016/j.paerosci.2023.100928>
26. Delbecq, S., Fontane, J., Gourdain, N., Planès, T., Simatos, F., "Sustainable aviation in the context of the Paris Agreement: A review of prospective scenarios and their technological mitigation levers," *Progress in Aerospace Sciences*, 141, 100920, 2023, <https://doi.org/10.1016/j.paerosci.2023.100920>
27. Afonso, F., Sohst, M., Diogo, C. M., et al., "Strategies towards a more sustainable aviation: A systematic review," *Progress in Aerospace Sciences*, 137, 100878, 2023, <https://doi.org/10.1016/j.paerosci.2022.100878>
28. Degirmenci, H., Uludag, A., Ekici, S., Karakoc, T. H., "Challenges, prospects and potential future orientation of hydrogen aviation and the airport hydrogen supply network: A state-of-art review," *Progress in Aerospace Sciences*, 141, 100923, 2023, <https://doi.org/10.1016/j.paerosci.2023.100923>
29. Abu Salem, K., Palaia, G., Bravo-Mosquera, P. D.,Quarta, A. A. "A review of novel and non-conventional propulsion integrations for next-generation aircraft," *Designs*, 8(2), 20, 2024, <https://doi.org/10.3390/designs8020020>
30. International Civil Aviation Organization. *Aerodromes: Volume I—Aerodrome Design and Operations*. International Standards and Recommended Practices; ICAO Annex 14: Montréal, QC, Canada, 2009.
31. Cipolla V., Frediani A., Abu Salem K., Picchi Scardaoni M., Nuti A., Binante V., "Conceptual design of a box-wing aircraft for the air transport of the future," *AIAA Aviation Forum, Aviation Technology, Integration, and Operations Conference*, Atlanta, GA, USA, Jun. 2018, doi: 10.2514/6.2018-3660
32. Cipolla V., Abu Salem K., Picchi Scardaoni M., Binante V., "Preliminary design and performance analysis of a box-wing transport aircraft," *AIAA SciTech Forum*, Orlando, FL, USA, 2020, doi: 10.2514/6.2020-0267
33. Picchi Scardaoni, M., Binante, V., Cipolla, V., "WAGNER: a new code for parametrical structural study of fuselages of civil transport aircraft," *Aerotecnica Missili & Spazio*, 96, 136–147, 2017, <https://doi.org/10.1007/BF03404748>
34. 3DS Dassault Systems Simulia, ABAQUS Unified FEA. Available online: <https://perma.cc/X8L3-JGSV>
35. Frediani A., Cipolla V., Abu Salem K., Binante V., Picchi Scardaoni M., "Conceptual design of PrandtlPlane civil transport aircraft," *Proceedings of the Institution of Mechanical Engineers, Part G: Journal of Aerospace Engineering*, vol. 234, 10, 2019, doi: 10.1177/0954410019826435
36. Abu Salem, K., Palaia, G., Carini, M., et al., "A CFD-Based Collaborative Approach for Box-Wing Aircraft Aerodynamic Assessment: The PARSIFAL Study Case," *Aerotecnica Missili & Spazio*, 102, 385–407, 2023, <https://doi.org/10.1007/s42496-023-00172-7>
37. Abu Salem K., Palaia G., Cipolla V., Binante V., Zanetti D., Chiarelli M., "Tools and methodologies for box-wing aircraft conceptual aerodynamic design and aeromechanic analysis," *Mechanics & Industry*, vol. 22,39, 2021, doi: 10.1051/meca/2021037
38. Rizzo E., Frediani A., "Application of Optimisation Algorithms to Aircraft Aerodynamics," *Variational Analysis and Aerospace Engineering*, Springer Optimization and Its Applications, vol. 33. Springer, New York, NY, 2009, https://doi.org/10.1007/978-0-387-95857-6_23
39. Rizzo E., "Optimization Methods Applied to the preliminary design of innovative non conventional aircraft configurations," *Ph.D. Thesis*, University of Pisa, 2009, <https://etd.adm.unipi.it/theses/available/etd-05122010-103814/>
40. Drela M., Youngren H., "AVL 3.36 User Primer," *Online Software Manual*, 2017, Available online: <https://perma.cc/R35R-W29F>
41. Raymer D. P., *Aircraft Design: A Conceptual Approach*, AIAA Education Series, 1992, <https://doi.org/10.2514/4.104909>
42. Cipolla V., Frediani A., Abu Salem K., Binante V., Rizzo E., Maganzi M., "Preliminary transonic CFD analyses of a PrandtlPlane transport aircraft," *Transportation Research Procedia*, Vol. 29, 2018, doi: 10.1016/j.trpro.2018.02.008
43. Carini M., Méheut M., Kanellopoulos S., Cipolla V., Abu Salem K., "Aerodynamic analysis and optimization of a boxwing architecture for commercial airplanes," *AIAA SciTech Forum*, Orlando, USA, 2020, doi: 10.2514/6.2020-1285
44. Abu Salem K., "Development of design tools and methods for box-wing airplanes and application of the PrandtlPlane concept to a short-medium range aircraft," *Ph.D. Thesis*, University of Pisa, 2021, <https://etd.adm.unipi.it/theses/available/etd-05312021-171241/>
45. Picchi Scardaoni M. P., Montemurro M., Panettieri, E., "PrandtlPlane wing-box least-weight design: A multi-scale optimisation approach," *Aerospace Science and Technology*, 106, 106156, 2020, <https://doi.org/10.1016/j.ast.2020.106156>
46. Cipolla V., Abu Salem K., Bachi F., "Preliminary stability analysis methods for PrandtlPlane aircraft in subsonic conditions," *Aircraft Engineering and Aerospace Technology*, vol. 91,3, 2018, doi: 10.1108/AEAT-12-2017-0284
47. van Ginneken D., Voskuil M., van Tooren M., Frediani A., "Automated control surface design and sizing for the prandtl plane," *51st AIAA Structures, Structural Dynamics, and Materials Conference*, Orlando, USA, Apr. 2010, <https://doi.org/10.2514/6.2010-3060>
48. Voskuil M., de Klerk J., van Ginneken D., "Flight Mechanics Modeling of the PrandtlPlane for Conceptual and Preliminary Design," *Variational Analysis and Aerospace Engineering: Mathematical Challenges for Aerospace Design*, Springer Optimization and Its Applications, vol 66, Springer, Boston, MA, 2012, https://doi.org/10.1007/978-1-4614-2435-2_19
49. Wahler, N. F., Varriale, C., La Rocca, G., "Impact of Control Allocation Methods on the Design of Control Surface Layouts for Box-Wing Aircraft under Flying Qualities Constraints," *AIAA Aviation Forum*, San Diego, CA, 12-16 June, 2023, <https://doi.org/10.2514/6.2023-3485>
50. Amato, F. D., "Direct Lift Control of a Prandtlplane Aircraft for Improved Landing Performances," *M.Sc. Thesis*, University of Pisa, 2019, <https://etd.adm.unipi.it/theses/available/etd-01302019-114303/>
51. de Wringer, S., Varriale, C., Oliviero, F., "A generalized approach to operational, globally optimal aircraft mission performance evaluation, with application to direct lift control," *Aerospace*, 7(9), 134, 2020, <https://doi.org/10.3390/aerospace7090134>
52. Abu Salem K., Cipolla V., Palaia G., Binante V., Zanetti D., "A Physics-Based Multidisciplinary Approach for the Preliminary Design and Performance Analysis of a Medium Range Aircraft with Box-Wing Architecture," *Aerospace*, 8(10):292, 2021, <https://doi.org/10.3390/aerospace8100292>

53. Risse K., Schäfer K., Schülke, F., Stumpf E., "Central reference aircraft data system (CeRAS) for research community," *CEAS Aeronautical Journal*, Vol. 7, pp. 121–133, 2021, <https://doi.org/10.1007/s13272-015-0177-9>
54. CeRAS, Central Reference Aircraft System, website, 2016, available online: <https://ceras.ilr.rwth-aachen.de/>
55. Arkell, D., "Moving toward the Middle," *Boeing Frontiers Magazine*, 2003, available online at: <https://www.boeing.com/news/frontiers/archive/2003/march/cover.html>
56. Tasca A. L., Cipolla V., Abu Salem K., Puccini, M., "Innovative box-wing aircraft: Emissions and climate change," *Sustainability*, 13(6), 3282, <https://doi.org/10.3390/su13063282>
57. Azar, C., Johansson, D. J., "Valuing the non-CO₂ climate impacts of aviation," *Climatic Change*, 111, 559-579, 2012, <https://doi.org/10.1007/s10584-011-0168-8>
58. Schmidt, M., "A review of aircraft turnaround operations and simulations," *Progress in Aerospace Sciences*, 92, 25-38, 2017, <https://doi.org/10.1016/j.paerosci.2017.05.002>
59. Wu, C. L., Caves, R. E., "Aircraft operational costs and turnaround efficiency at airports," *Journal of Air Transport Management*, 6(4), 201-208, 2000, [https://doi.org/10.1016/S0969-6997\(00\)00014-4](https://doi.org/10.1016/S0969-6997(00)00014-4)
60. Scardaoni, M. P., Magnacca, F., Massai, A., Cipolla, V., "Aircraft turnaround time estimation in early design phases: Simulation tools development and application to the case of box-wing architecture," *Journal of Air Transport Management*, 96, 102122, 2021, <https://doi.org/10.1016/j.jairtraman.2021.102122>
61. Magnacca, F., Abu Salem, K., Cipolla, V., "Economic assessment of box-wing aircraft architecture: methodology and application in the Parsifal project," *Proceedings of the XXVI AIDAA International Congress* (pp. 545-554), Casa Editrice Persiani, Pisa, Italy, 2021.
62. Magnacca, F., "Management accounting practices and value creation in the PARSIFAL project. A pragmatic constructivist approach to new product development in the air transportation industry," *Ph.D. Thesis*, University of Pisa, 2021, <https://etd.adm.unipi.it/theses/available/etd-03032021-164447/>
63. Thorbeck, J., Scholz, D., "DOC-Assessment method," *3rd Symposium on Collaboration in Aircraft Design*, Linköping, Sweden, 2013, available online at: https://www.fzt.haw-hamburg.de/pers/Scholz/Aero/TU-Berlin_DOC-Method_with_remarks_13-09-19.pdf
64. Scholz, A.E.; Trifonov, D.; Hornung, M. "Environmental life cycle assessment and operating cost analysis of a conceptual battery hybrid-electric transport aircraft," *CEAS Aeronautical Journal*, 13, 215–235, 2022, <https://doi.org/10.1007/s13272-021-00556-0>
65. PARSIFAL Project Consortium, "Report on operational and economic assessment," *PARSIFAL Project Deliverables*, D 1.2, 2020, available online at: <https://cordis.europa.eu/project/id/723149/results>
66. Breije B. J., Martins, J. R., "Electric, hybrid, and turboelectric fixed-wing aircraft: A review of concepts, models, and design approaches," *Progress in Aerospace Sciences*, 104, 1-19, 2019, <https://doi.org/10.1016/j.paerosci.2018.06.004>
67. Orefice F., Nicolosi F., Della Vecchia P., Ciliberti D., "Aircraft conceptual design of commuter aircraft including distributed electric propulsion," *AIAA Aviation Forum*, virtual event, 2020, <https://doi.org/10.2514/6.2020-2627>
68. Isikveren A. T., Fefermann Y., Maury C., Level C., Zarati K., Salanne J. P., Pomet C., Thoraval B., "Pre-design of a commuter transport utilising Voltaic-Joule/Brayton motive power systems," *The Aeronautical Journal*, 122(1248), 205-237, 2018, <https://doi.org/10.1017/aer.2017.126>
69. de Vries R., Brown M., Vos R., "Preliminary Sizing Method for Hybrid-Electric Distributed-Propulsion Aircraft," *Journal of Aircraft*, Vol. 56, N. 6, p. 2172-2188, 2019, doi: 10.2514/1.C035388
70. Karpuk S., Elham A., "Influence of Novel Airframe Technologies on the Feasibility of Fully-Electric Regional Aviation," *Aerospace*, 8-163, p. 1-29, 2021, doi: 10.3390/aerospace8060163
71. Sgueglia A., Schmollgruber P., Bartoli N., et al., "Multidisciplinary Design Optimization Framework with Coupled Derivative Computation for Hybrid Aircraft," *Journal of Aircraft*, Vol. 57, N. 4, p. 715-729, 2020, doi: 10.2514/1.C035509
72. Gnad A., Speth R., Sabnis J., Barrett S., "Technical and environmental assessment of all-electric 180-passenger commercial aircraft," *Progress in Aerospace Sciences*, Vol. 105, p.1-30, 2019, doi: 10.1016/j.paerosci.2018.11.002
73. Abu Salem, K., Palaia, G., Quarta, A.A., Chiarelli, M.R., "Medium-Range Aircraft Conceptual Design from a Local Air Quality and Climate Change Viewpoint," *Energies*, 16, 4013, 2023, <https://doi.org/10.3390/en16104013>
74. Palaia, G. "Design and performance assessment methodologies for box-wing hybrid-electric aircraft from urban to regional transport applications," *Ph.D. Thesis*, University of Pisa, 2022, <https://etd.adm.unipi.it/etd-11092022-150110/>
75. Palaia, G.; Zanetti, D.; Abu Salem, K.; et al. "THEA-CODE: A design tool for the conceptual design of hybrid electric aircraft with conventional or unconventional airframe configurations," *Mechanics and Industry*, Vol. 22, 2021, <https://doi.org/10.1051/meca/2021012>
76. Palaia, G.; Abu Salem, K. "Mission Performance Analysis of Hybrid-Electric Regional Aircraft," *Aerospace*, 10, 246, 2023, <https://doi.org/10.3390/aerospace10030246>
77. Cipolla, V.; Abu Salem, K.; Palaia, G.; Binante, V.; Zanetti, D. "A DoE-based approach for the implementation of structural surrogate models in the early stage design of box-wing aircraft," *Aerospace Science and Technology*, 2021, 117, 106968. <https://doi.org/10.1016/j.ast.2021.106968>
78. Wells, D.P.; Horvath, B.L.; McCullers, L.A. "The Flight Optimization System Weights Estimation Method," NASA Tech. Rep. 2017. Available online: <https://ntrs.nasa.gov/citations/20170005851>
79. Abu Salem K., Palaia G., Quarta, A. A., "Impact of Figures of Merit Selection on Hybrid-Electric Regional Aircraft Design and Performance Analysis," *Energies*, 16(23), 7881, <https://doi.org/10.3390/en16237881>
80. Abu Salem K., Palaia G., Quarta, A. A., "Review of hybrid-electric aircraft technologies and designs: Critical analysis and novel solutions," *Progress in Aerospace Sciences*, 141, 100924, <https://doi.org/10.1016/j.paerosci.2023.100924>
81. Eisenhut, D.; Moebs, N.; Windels, E.; Bergmann, D.; et al. "Aircraft Requirements for Sustainable Regional Aviation," *Aerospace* 2021, 8, 61. <https://doi.org/10.3390/aerospace8030061>
82. Palaia, G., Abu Salem, K., Quarta, A.A., "Comparative Analysis of Hybrid-Electric Regional Aircraft with Tube-and-Wing and Box-Wing Airframes: A Performance Study," *Applied Sciences*, 13, 2023, <https://doi.org/10.3390/app13137894>
83. Abu Salem, K., Palaia, G., Quarta, A.A., "Introducing the Box-Wing Airframe for Hybrid-Electric Regional Aircraft: A Preliminary Impact Assessment," *Applied Sciences*, 13, 2023, <https://doi.org/10.3390/app131810506>
84. Abu Salem, K., Palaia, G., Chiarelli, M.R., Bianchi, M., "A Simulation Framework for Aircraft Take-Off Considering Ground Effect Aerodynamics in Conceptual Design," *Aerospace*, 10, 2023, <https://doi.org/10.3390/aerospace10050459>
85. Abu Salem K., "Studio Sulla Configurazione Aerodinamica di Velivoli Civili di Tipo PrandtlPlane di Piccole e Medie Dimensioni," (trad. "Analysis of the aerodynamic configuration of small-medium sized PrandtlPlane civil aircraft") *M.Sc. Thesis*, University of Pisa, Italy, 2016, available at: <https://etd.adm.unipi.it/theses/available/etd-06222016-110207/>

86. Sollo, A., "P.180 Avanti: An Iconic Airplane and the Achievement of an Historical Milestone," *Aerotecnica Missili & Spazio*, 100, 69–78, 2021, <https://doi.org/10.1007/s42496-020-00073-z>
87. Zangani G., "Un approccio multidisciplinare alla metaprogettazione aeronautica," (trad. "A multidisciplinary approach to aeronautical meta-design"), *M.Sc. Thesis*, ISIA, Florence, Italy, 2016
88. Frediani, A., Cipolla, V., Oliviero, F., "Design of a prototype of light amphibious PrandtlPlane," *56th AIAA/ASCE/AHS/ASC Structures, Structural Dynamics, and Materials Conference*, Kissimmee, FL, USA, 5-9 January 2015, <https://doi.org/10.2514/6.2015-0700>
89. Cipolla, V., Frediani, A., Lonigro, E., "Aerodynamic design of a light amphibious PrandtlPlane: wind tunnel tests and CFD validation," *Aerotecnica Missili & Spazio*, 94, 113–123, 2015, <https://doi.org/10.1007/BF03404694>
90. Oliviero, F., Zanetti, D., Cipolla, V., "Flight dynamics model for preliminary design of PrandtlPlane wing configuration with sizing of the control surface," *Aerotecnica Missili & Spazio*, 95, 201–210, 2016, <https://doi.org/10.1007/BF03404728>
91. Viti, A., "CFD aerodynamic design of an ultra-light amphibious PrandtlPlane aircraft," *M.Sc. Thesis*, University of Pisa, Italy, 2012, available at: <https://etd.adm.unipi.it/theses/available/etd-11062012-172107/>
92. Frediani, A., Cipolla, V., Oliviero, F., "IDINTOS: the first prototype of an amphibious PrandtlPlane-shaped aircraft," *Aerotecnica Missili & Spazio*, 94, 195–209, 2015, <https://doi.org/10.1007/BF03404701>
93. Frediani, A., Cipolla, V., Oliviero, F., et al., "A new ultralight amphibious PrandtlPlane: preliminary CFD design of the hull," *Aerotecnica Missili & Spazio*, 92, 77–86, 2013, <https://doi.org/10.1007/BF03404665>
94. Chambers, J. R., *Modeling Flight: The Role of Dynamically Scaled Free-Flying Models in NASA's Research Program*, NASA SP 2009-575, 2015, ISBN: 9780160846335
95. Santarini A., "Analisi strutturale di sistemi portanti boxwing di velivoli ultraleggeri," (trad. "Structural analysis of boxwing lifting systems for ultralight aircraft"), *M.Sc. Thesis*, University of Pisa, Italy, 2013, available at: <https://etd.adm.unipi.it/theses/available/etd-06192013-230347/>
96. Cipolla, V., Binante, V., Nardone, A., "Design, Optimization and Manufacturing of Metallic Wings of Light Aircraft," *Aerotecnica Missili & Spazio*, 97, 219–227, 2018, <https://doi.org/10.1007/BF03406056>
97. Oliviero, F., "Preliminary design of a very large PrandtlPlane freighter and airport network analysis," *Ph.D. Thesis*, University of Pisa, Italy, 2015, available at: <https://etd.adm.unipi.it/theses/available/etd-12152015-103232/>
98. Oliviero, F., Frediani, A., "Conceptual Design of a Very Large PrandtlPlane Freighter," *Variational Analysis and Aerospace Engineering: Mathematical Challenges for Aerospace Design*, 66. Springer, 2012, https://doi.org/10.1007/978-1-4614-2435-2_13
99. Cappelli, L., Costa, G., Cipolla, V., A. Frediani, F. Oliviero, E. Rizzo, "Aerodynamic optimization of a large PrandtlPlane configuration," *Aerotecnica Missili & Spazio*, 95, 163–175, 2016, <https://doi.org/10.1007/BF03404725>
100. Cappelli, L., Costa, G., "Aerodynamic optimization of a large PrandtlPlane configuration," *M.Sc. Thesis*, University of Pisa, Italy, 2015, available at: <https://etd.adm.unipi.it/theses/available/etd-01262015-123524/>
101. Oliviero, F., "Conceptual design of a large PrandtlPlane freighter," *M.Sc. Thesis*, University of Pisa, Italy, 2010, available at: <https://etd.adm.unipi.it/theses/available/etd-06242010-000726/>
102. Frediani, A., Oliviero, F., Rizzo, E., "Design of an airfreight system based on an innovative PrandtlPlane aircraft," *56th AIAA/ASCE/AHS/ASC Structures, Structural Dynamics, and Materials Conference*, Kissimmee, FL, USA, 5-9 January 2015, <https://doi.org/10.2514/6.2015-1186>
103. Bauranov, A., Rakas, J., "Designing airspace for urban air mobility: A review of concepts and approaches," *Progress in Aerospace Sciences*, 125, 100726, 2021, <https://doi.org/10.1016/j.paerosci.2021.100726>
104. Bacchini, A., Cestino, E., "Electric VTOL Configurations Comparison," *Aerospace*, 6, 26, 2019, <https://doi.org/10.3390/aerospace6030026>
105. Ugwueze, O., Statheros, T., Bromfield, M. A., Horri, N., "Trends in eVTOL aircraft development: the concepts, enablers and challenges," *AIAA SciTech Forum*, National Harbor, USA, 23-27 January, 2023, <https://doi.org/10.2514/6.2023-2096>
106. Palaia G., Abu Salem K., Cipolla V., Binante V., Zanetti D., "A conceptual design methodology for e-VTOL aircraft for urban air mobility," *Applied Sciences*, 11(22), 10815, 2021, <https://doi.org/10.3390/app112210815>
107. Xiang, S., Xie, A., Ye, M., et al., "Autonomous eVTOL: A summary of researches and challenges," *Green Energy and Intelligent Transportation*, 100140, 2024, <https://doi.org/10.1016/j.geits.2023.100140>
108. Palaia, G., Abu Salem, K., Cipolla, V., et al., "Preliminary design of a Tiltwing UAV with a box wing configuration," *Aerotecnica Missili & Spazio*, 97, 198–207, 2018, <https://doi.org/10.1007/BF03406054>
109. Palaia, G., Cipolla, V., Binante, V., Rizzo, E., "Preliminary design of a box-wing VTOL UAV," *Aircraft Engineering and Aerospace Technology*, Vol. 92 No. 5, pp. 737-743, 2020, <https://doi.org/10.1108/AEAT-06-2019-0121>
110. Fioriti, M., Cabaleiro, C., Lefebvre, T., et al., "Multidisciplinary design of a more electric regional aircraft including certification constraints," *AIAA Aviation Forum*, Chicago, USA, Jun. 27-Jul. 1, 2022, <https://doi.org/10.2514/6.2022-3932>
111. Xie, J., Chakraborty, I., Briceno, S. I., Mavris, D. N., "Development of a certification module for early aircraft design," *AIAA Aviation Forum*, Dallas, USA, 17-21 June 2019, <https://doi.org/10.2514/6.2019-3576>