

Circuit Theory Inspired Solutions for Energy Harvesting Applications

Original

Circuit Theory Inspired Solutions for Energy Harvesting Applications / Bonnin, M.; Song, Kailing; Traversa, Fabio Lorenzo; Bonani, Fabrizio. - ELETTRONICO. - (2023), pp. 181-182. (Intervento presentato al convegno Micro and Nanotechnology for Power Generation and Energy Conversion Applications (PowerMEMS) tenutosi a Abu Dhabi, United Arab Emirates nel 11-14 December, 2023) [10.1109/PowerMEMS59329.2023.10417679].

Availability:

This version is available at: 11583/2986477 since: 2024-03-01T07:36:58Z

Publisher:

IEEE

Published

DOI:10.1109/PowerMEMS59329.2023.10417679

Terms of use:

This article is made available under terms and conditions as specified in the corresponding bibliographic description in the repository

Publisher copyright

IEEE postprint/Author's Accepted Manuscript

©2023 IEEE. Personal use of this material is permitted. Permission from IEEE must be obtained for all other uses, in any current or future media, including reprinting/republishing this material for advertising or promotional purposes, creating new collecting works, for resale or lists, or reuse of any copyrighted component of this work in other works.

(Article begins on next page)

Circuit theory inspired solutions for energy harvesting applications.

M. Bonnin¹, K. Song^{1,2}, F.L. Traversa³, and F. Bonani¹

¹Politecnico di Torino, Torino, Italy, ²IUSS University School for Advanced Studies, Pavia, Italy, and ³Memcomputing Inc, CA, US

In this work, we propose and analyze two solutions, inspired from circuit theory, to design energy harvesters with improved performances [1,2]. The pros and cons of both solutions are discussed, and their ideal application range is outlined. Our theoretical and numerical analysis shows that the proposed solutions outperform traditional energy harvesting systems both in terms of harvested power and of power efficiency.

The first solution that we consider, is based on impedance matching theory [2]. The maximum power transfer theorem states that maximum power is absorbed by the load, if its impedance is the complex conjugate of the source impedance. Typically, energy harvesting systems are composed by an oscillating structure, a mechanical-to-electrical energy transducer, and an electrical load (Fig. 1(a)). The limited power efficiency is the consequence of the very different impedance of the mechanical and the electrical parts. A possible solution consists in interposing a matching network between the source and the load (Fig. 1(b)). The matching network is ideally composed of reactive elements (inductors and capacitors), that do not absorb average power, but they modify the load impedance. Application of the matching network permits to obtain very high average harvested power, with very high-power efficiency. Unfortunately, to achieve optimal performances, the matching network often must include very large inductors. This limitation is particularly serious in applications of energy harvesting at very low frequency. In fact, electrical circuits are characterized by resonance frequencies that are several orders of magnitude higher than those of mechanical systems. As a rule of thumb, the resonance frequency of a mechanical object is inversely proportional to its size. Therefore, miniaturized harvesters have relatively high resonance frequencies, that are closer to that of electrical circuits. On the contrary, to match the low resonance frequency of a large mechanical system, a very large inductance is required.

The second proposed solution consists in an application of filter theory (Fig. 1(c)). Passive filters are electronic circuits designed to transmit/block signals within a given frequency band. Similarly, energy harvesters are designed to capture energy, and convey it to a load. This suggests the idea to apply filter theory to design energy harvesters with optimal performances. Using mechanical-to-electrical analogies (Table 1), equivalent circuits for the electro-mechanical energy harvesters can be derived. A passband filter with Cauer topology, is interposed between the voltage source, representing ambient energy source, and the equivalent circuit. The passband filter is optimized to maximize the power transmitted to the load. Using electrical-to-mechanical analogy, the filter corresponds to a mechanical filter, composed by a chain of harmonic oscillators. Multi-degrees of freedom systems composed by chain of oscillators have already been considered in the past, but their design and optimization has not been discussed. Practical realization of a mechanical filter can be quite complicated, and this solution offers less power performances with respect to the impedance matching solution. On the other hand, the problem of very high inductances is eliminated.

We support our considerations, here summarized in the results in Table 2, with theoretical results and numerical simulations.

force → voltage
displacement → charge
velocity → current
mass → inductance
compliance (1/stiffness) → capacitance
damping → resistance

Table 1. Electro-mechanical analogies.

Solution setup	Average harvested power
Simple resistive load	65 μW
Matched load	115 μW
Mechanical Filter, 1 st order	92 μW
Mechanical Filter, 2 nd order	97 μW

Table 2. Power performance comparison.

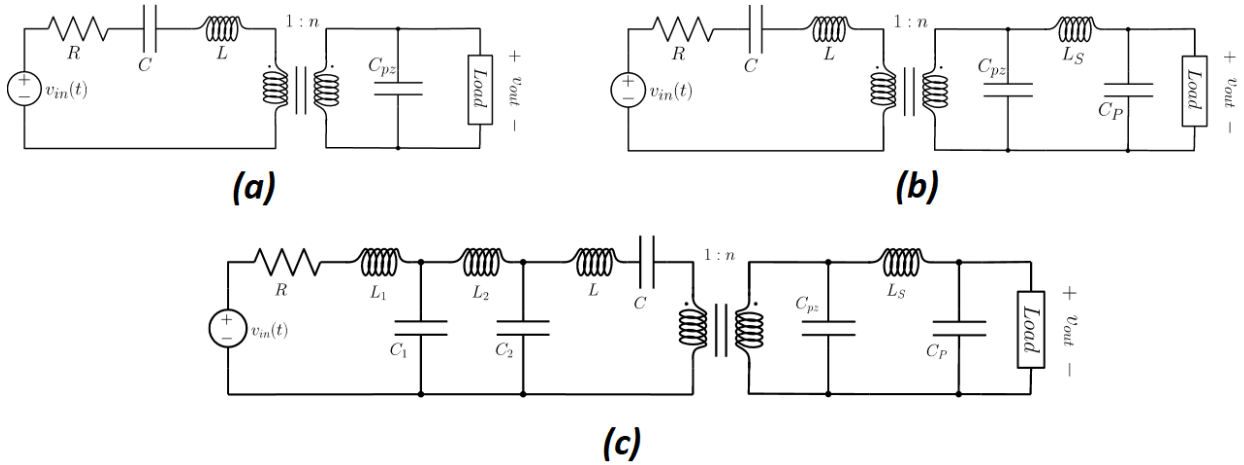

Figure 1. Equivalent circuits for a piezoelectric (PZ) energy harvester. (a) PZ energy harvester with resistive load. (b) PZ energy harvester with matched load. (c) PZ energy harvester with mechanical filter composed by a chain of harmonic oscillators.

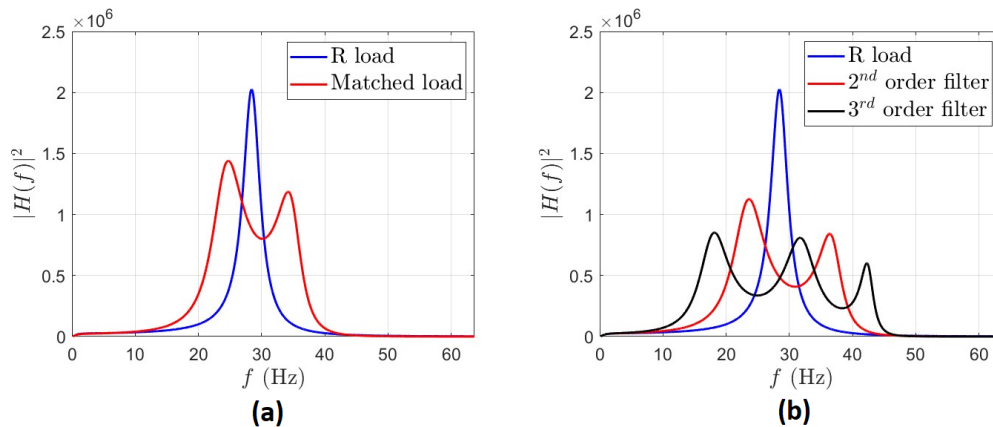

Figure 2. Transfer function of a simple energy harvester with resistive load (blue line), and the two proposed solutions. Harvested power is proportional to the area under the curves. (a) Matching network (red line). (b) Mechanical filter (red and black lines). In both solutions power at the resonant frequency is traded for larger bandwidth.

Submitting author: M. Bonnin, Department of Electronics and Telecommunications, Politecnico di Torino, Torino, Italy, Tel: +39-011-090-4089; E-mail: michele.bonnin@polito.it

References

- [1] K. Song *et al*, *Nonlinear Dynamics*, 111 (2023), pp. 16991-17005.
- [2] M. Bonnin *et al*, *Energies*, 15(8) (2022), pp. 2764.