

Exploitation of deployed telecommunication fiber infrastructures for sensing applications

*Original*

Exploitation of deployed telecommunication fiber infrastructures for sensing applications / Boffi, P.; Di Luch, I.; Ferrario, M.; Rizzelli Martella, G.; Gaudino, R.. - ELETTRONICO. - 2020-(2020), pp. 1-4. (Intervento presentato al convegno 22nd International Conference on Transparent Optical Networks, ICTON 2020 tenutosi a ita nel 2020) [10.1109/ICTON51198.2020.9203016].

*Availability:*

This version is available at: 11583/2859722 since: 2021-04-24T15:21:30Z

*Publisher:*

IEEE Computer Society

*Published*

DOI:10.1109/ICTON51198.2020.9203016

*Terms of use:*

This article is made available under terms and conditions as specified in the corresponding bibliographic description in the repository

*Publisher copyright*

IEEE postprint/Author's Accepted Manuscript

©2020 IEEE. Personal use of this material is permitted. Permission from IEEE must be obtained for all other uses, in any current or future media, including reprinting/republishing this material for advertising or promotional purposes, creating new collecting works, for resale or lists, or reuse of any copyrighted component of this work in other works.

(Article begins on next page)

# Exploitation of Deployed Telecommunication Fiber Infrastructures for Sensing Applications

P. Boffi<sup>1</sup>, I. Di Luch<sup>1</sup>, M. Ferrario<sup>1</sup>, G. Rizzelli<sup>2</sup>, and R. Gaudino<sup>2</sup>

<sup>1</sup>Politecnico di Milano, Dept. Electronics, Information and Bioengineering, Via Ponzio 34/5, Milano, Italy

<sup>2</sup>Politecnico di Torino, Dept. Electronics and Telecommunications, Corso Duca degli Abruzzi 24, Torino, Italy

e-mail: pierpaolo.boffi@polimi.it

## ABSTRACT

The optical fiber infrastructure deployed in our cities to support the metropolitan area networks is exploited for sensing applications, where the optical sensing signals co-propagate together with the telecom traffic. Thanks to a coherent interferometric approach, structural monitoring of buildings can be achieved in deployed passive optical networks based on fiber-to-the-home structure. Moreover, the same technology is experimented in urban fibre ring networks to detect and localize mechanical vibrations or dynamic perturbation.

**Keywords:** metro networks, fiber sensors, interferometric sensors.

## 1. INTRODUCTION

Nowadays, the 90% of the total telecom data traffic is concentrated in the 5% of the geographical area [1], i.e. not in the long-haul transport network, but in the metropolitan and access networks. Hundreds of km of fibers are already deployed in our cities. The industry trends estimate a continuous investment in urban fiber infrastructures by traditional telecom operators, communications service providers and public-private partnerships, to improve very high-speed access, new residential and business connectivity services and wireless densification for 5G. Regarding 5G development, more deep fiber will be necessary to connect the large quantity of small cells and hotspots in order to ensure the foreseen 4-fold increase in the mobile data traffic in the next years. Moreover, the reinforcement of fiber to the home (FTTH) solutions is mandatory to face the issue of the present “digital divide”.

The present and future large fiber infrastructure installed in our cities can be exploited as a pervasive sensor as well. The optical fiber can not only carry the telecom data, but also be in the same time the sensing medium sensitive to the physical parameters to be measured, such as temperature, strain, vibration, etc. Not special sensing components, such as fiber Bragg gratings (FBGs) are required, providing an added value to the fiber infrastructure itself, where the optical sensing signals and the telecom traffic can co-propagate together.

Optical fiber cables are usually employed as sensors to supervise gas&oil [2] and hydraulic pipelines [3], and also manufacturing machine diagnostic can be performed [4, 5]. Recently, vehicle speed and car density in a road [6] and the onset of seismic and ground motions [7] have been monitored in a deployed fiber carrying simultaneously high-speed data traffic. These experimental proofs made use of complex and expensive sensing systems, for example based on phase optical time domain reflectometer (phase-OTDR) to recover distributed vibration patterns along the optical fiber link.

In this paper we present the exploitation of a deployed metropolitan fiber infrastructure running in the city of Turin in Italy, devoted to telecom applications, to assess the performance of coherent sensing solution, providing a fruitful synergy between telecommunications and sensing. In particular, we demonstrate the surveillance of urban buildings, assuring the coexistence with standard downstream 10-Gb/s traffic. The condition of the road and the optical cable health itself is also monitored thanks to a real-time diagnostic of the embedded cable. The adoption of the coherent interferometric approach allows to achieve reliable embedded sensing systems with simple implementation supported by off-the-shelf low-cost instrumentations.

## 2. DEPLOYED METROPOLITAN FIBER INFRASTRUCTURE IN TURIN

The fiber infrastructure exploited in our experimentation is deployed in the city of Turin, Italy, by one of the Italian FTTH operators for telecom applications. The link shown in Fig. 1b comprises of spans of single-mode fiber (SMF) of different lengths, enclosed in normal conduits, connecting the lab of Politecnico di Torino. The fiber layout can be organized in several topologies, according to the interconnections among the network sections and applications. In particular, an optical link of 11 km operating as a passive optical network (PON) connection is considered, with two optical network units (ONUs) devoted for monitoring the structural integrity of city buildings. In the same way, we select a 32-km SMF ring used to demonstrate the detection and localization of vibrations and mechanical stress applied to the network cable with a spatial accuracy of few meters.

## 3. PERVASIVE MONITORING OF CIVIL BUILDINGS AND FACILITIES THROUGH PON

The structural integrity of city buildings, such as skyscrapers, can be subject to dynamic deformations, i.e. vibrations, occurring continuously or in case of critical events. The detection of such a deformation may indicate the beginning of a structural failure. FTTH solution, providing fiber connection to each residential apartment, can be exploited for this kind of monitoring. In our implementation based on a simple coherent interferometric approach, two ONU fibers at the output of the PON 1xN splitter are devoted to the sensing functionalities

(as shown in Fig. 1a) [8]. They are terminated with Faraday rotator mirrors (FRM) to back-reflect signals at 1550 nm. The C band is used for the sensing purposes, while the downstream telecom signal remains at the standard O band. The two mirrored ONU fibers constitute the sensing and reference arms of a Michelson interferometer, where the demodulation of the interferometric signal occurs inside the splitter in a similar way to what happens in a  $1 \times 2$  coupler. FRMs assure the retracing of signal polarizations to avoid fading impairments [9]. In this configuration, the trunk fiber connecting the central office to the splitter does not introduce any phase noise contribution as the phase shift induced by the vibration is immediately converted into amplitude after the splitter.

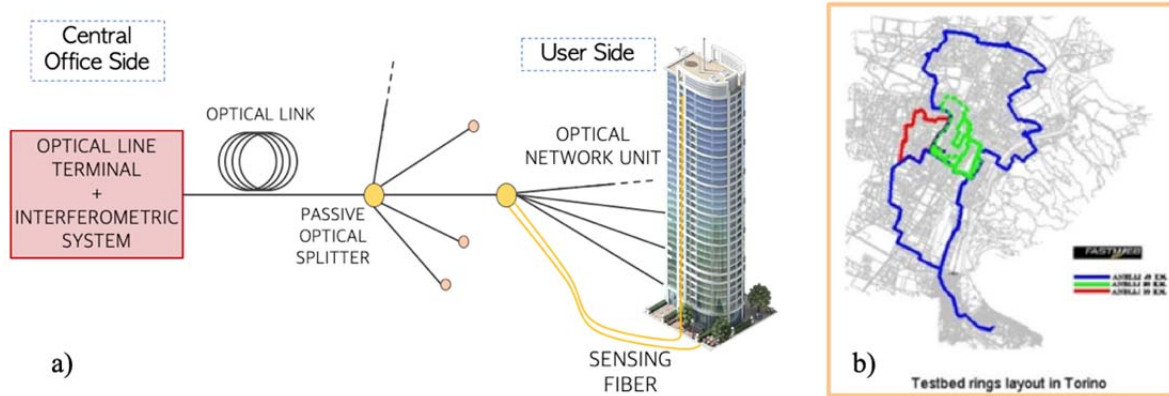

Figure 1: a) PON access network architecture exploited for building structural monitoring; b) Deployed metropolitan fiber infrastructure in Turin.

In order to demonstrate the capabilities of such interferometric approach, we fed the PON at the central office side with a 1550-nm sensing beam emitted by narrow-linewidth optical source, copropagating in the link with a downstream 10-Gb/s NRZ signal at 1310 nm. At the user side a piezoelectric (PZT) transducer was applied to the sensing fiber to induce dynamic strain variations in the range of few Hz, to emulate structural vibrations, which cause a phase shift between the two arms of the Michelson interferometer. After back-propagating inside the fiber link coexisting with the data traffic, the interferometric signal is detected and thanks to the digital phase-generated carrier (PGC) homodyne technique [10] the differential phase induced by the vibration is recovered. In the SMF infrastructure deployed in Turin described before, a 11-km fiber links (with 10-dB roundtrip loss) has been considered, combined with different splitting ratios for the  $1 \times N$  splitter ( $1 \times 4$ ,  $1 \times 8$ , and  $1 \times 16$ ) in order to assess the PON impact on the accuracy in the vibration monitoring. In our experimentation, both the central office and user sides were located in Politecnico di Torino lab. In particular, the received electrical signal-to-noise ratio (SNR) has been evaluated, considering the spectral amplitude of the vibration first harmonic (in our experimentation at 3 Hz) and the spectral noise level evaluated on a 0.1-Hz bandwidth. The measured SNR (reported in Fig. 2a) remains almost constant for the input sensing power owing to the backscattering contributions induced along the link, increasing linearly with the input power.

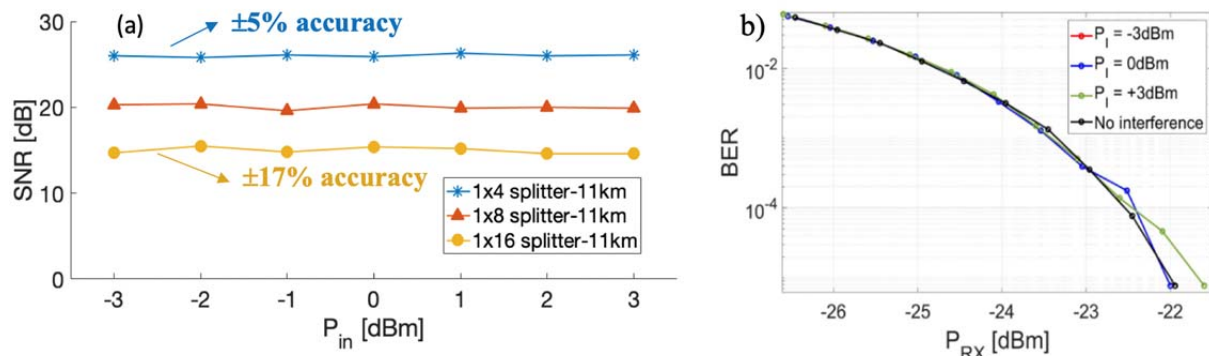

Figure 2: a) SNR vs input sensing power in case of 11-km PON link; b) BER vs. received downstream signal power, for different levels of sensing signal power.

From the measures it is demonstrated that 26-dB SNR (achieved with  $1 \times 4$  splitter) is enough to assure  $\pm 5\%$  strain accuracy in vibration detection, while the use of  $1 \times 16$  splitter decreases the SNR to 15 dB, still able to assure an acceptable  $\pm 17\%$  strain accuracy. Figure 2b shows the BER measured for the downstream 10-Gb/s signal in case of  $1 \times 8$  splitter, demonstrating negligible impact of the sensing signals copropagating in the PON with the downstream data.

#### 4. OPTICAL NETWORK SURVEILLANCE IN A METRO FIBER RING

The ring layout of the metro network opens the possibility of new sensing applications, running on a dedicated wavelength in parallel to all the other WDM telecom channels. In particular, a counter-propagating interferometric scheme allows to detect and localize the onset of vibrations and dynamic fiber stress along the entire link, in order to prevent dangerous damages or breakages, that are topical issues causing prolonged out of service and time-consuming and high-cost repairs for the telecommunication network. In this case, a dual Mach-Zehnder interferometer (MZI) arranged in a loop configuration is exploited (Fig. 3), where the clockwise (CW) and the counter-propagating counter-clockwise (CCW) waves travel along the two fiber arms of the interferometer inside the same deployed optical cable [11]. The two fibers act as the sensing and reference arm of each MZI. When a mechanical or acoustic vibration acts on the fiber loop, an additional phase modulation is generated in the optical signals, which propagate in the two opposite directions. Vibration localization is achieved by evaluating the time delay between the two counter-propagating phase modulations at the receivers. Typically, the reference arm in the MZI is kept isolated by the measurement area. In our arrangement we use as reference arm a fiber inside the same deployed cable. In fact, the phase noise accumulated by the sensing arm deployed in the fiber infrastructure is very strong, owing to the city environment. By exploiting the proposed scheme, the reference and the sensing arms accumulate the same common mode noise that can be cancelled by a balance detection at the receiver. Of course, the reference arm is affected itself by the vibration, but just a slight difference in the geometrical arrangement of the fibers in the cable allows to reveal the vibration. The coexistence with telecom data is assured by devoting just a single wavelength in the WDM grid comb to the sensing applications, leaving all the other wavelengths available for the data traffic transmission.

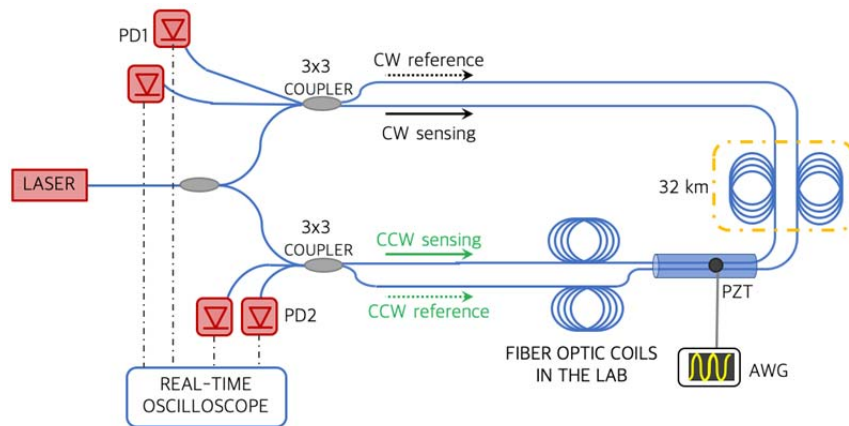

Figure 3. Dual MZI arranged in the metro fiber ring exploited for vibration detection and localization.

The proposed sensing system has been experimented in a 32-km SMF ring of the deployed Turin infrastructure. We applied to the fiber cable crossing the Politecnico di Torino lab a vibration generated by a PZT transducer to emulate a dynamic stress event. The interferometric signals were detected by photoreceivers with a bandwidth of 125 MHz, sampled at 20 MS/s and then processed to recover the phases and evaluate the relative time delay. The sampling rate allows to assure around 10-m spatial resolution in the event localization, considered a good compromise between a reduced DSP complexity and spatial accuracy in fault localization. In Fig. 4 an example of localization of the onset of the dynamic event is shown, considering a 5-kHz vibration applied after 1 km. The measured delay, achieved as a mean value after repeated measures, is 153.3  $\mu$ s, corresponding to an estimated position of 1,015 m, in agreement with the point of application of the vibration, with an accuracy of  $\pm 15$  m.

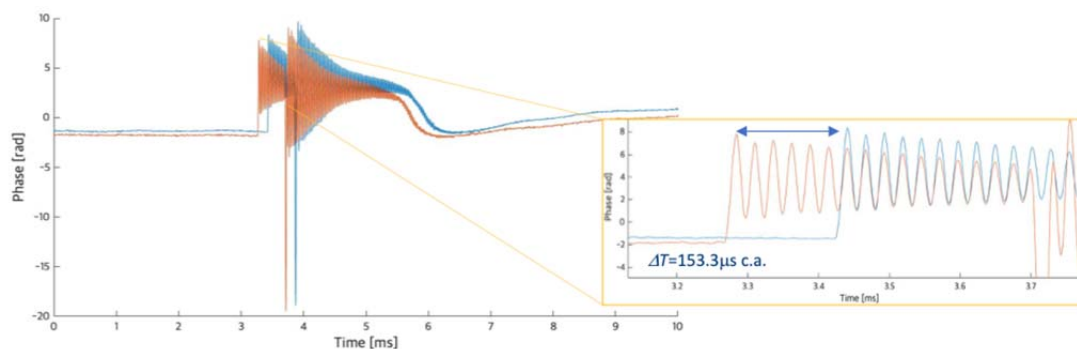

Figure 4. Recovered phase modulation by the CW (in orange) and CCW interferometer (in blue). In the inset the measured time delay.

## 5. CONCLUSIONS

We proposed coherent interferometric sensing architectures exploiting the installed metropolitan fiber network for the monitoring of vibrations and the detection of the onset of dynamic stress events in civil buildings connected by FTTH access links and in the whole deployed cable infrastructure. All the sensing monitoring is achieved preserving the coexistence with the high-speed telecom data traffic transmission. Preliminary assessments of the proposed sensing solutions have been experimented by exploiting the metro fiber link deployed in the city of Turin.

For the PON-based architecture, the backscattering contributions affect the received SNR, depending on the roundtrip losses and the splitting ratio of the employed  $1 \times N$  splitter, and determine the actual strain accuracy in vibration detection.

On the other hand, in case of ring-based dual MZI scheme (Fig. 5), the spatial resolution in the event localization depends on the adopted sampling rate at the receiver: 10-meter spatial resolution has been demonstrated with off-the-shelf programmable 20-MS/s sampling boards, without the necessity of complex and expensive sensors, such as phase-OTDR. The proposed sensing solutions provide significant added value to the present and future installed metro fiber infrastructure, that can turn into simple and reliable embedded systems for optical surveillance, preventing dangerous damages to both urban buildings and the optical network infrastructure itself, providing an unprecedented and fruitful synergy between telecommunications and sensing applications.

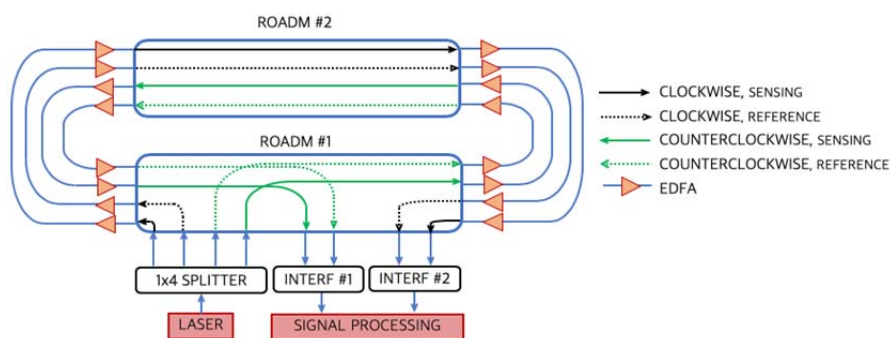

Figure 5. Application of the proposed sensing architecture in a ring network in presence of ROADMs.

## REFERENCES

- [1] Viavi 2018, <https://blog.viavisolutions.com/2018/07/10/viavi-releases-2018-state-of-the-network-study/>
- [2] A. Kersey, "Optical fiber sensors for permanent downwell monitoring applications in the oil and gas industry," *IEICE Trans. Electron.*, vol. E83-C, no. 3, pp. 400-404, 2000.
- [3] P. Boffi *et al.*, "Coherent optical fiber interferometric sensor for incipient cavitation index detection," *Flow Measurement and Instrumentation*, vol. 66, pp. 37-43, 2019.
- [4] M. Ferrario *et al.*, "A software-defined coherent fiber optic sensor for manufacturing machine diagnostic", in *Proc. 11th IEEE Sensors Applications Symposium (SAS)*, 2016, paper 7479852.
- [5] J. Morosi *et al.*, "Phase-coded Brillouin optical correlation domain analysis for extreme temperature sensing", in *Proc. European Conference on Lasers and Electro-Optics (CLEO Europe 2019)*, 2019, paper 2019-ch\_13\_5.
- [6] A. Glenn *et al.*, "First field trial of sensing vehicle speed, density and road conditions by using fiber carrying high speed data," in *Proc. 2019 Optical Fiber Communications Conference (OFC 2019)*, San Diego, CA, 2019, paper Th4C.7.
- [7] P. Jousset *et al.*, "Dynamic strain determination using fibre-optic cables allows imaging of seismological and structural features," *Nature Communications*, vol. 9, p. 2509, 2018.
- [8] I. Di Luch *et al.*, "Demonstration of structural vibration sensing in a deployed PON infrastructure," in *Proc. 45th European Conference on Optical Communication (ECOC 2019)*, Dublin, 2019.
- [9] M. Martinelli, "A universal compensator for polarization change induced by birefringence on a retracing beam," *Opt. Comm.*, vol. 72, p. 341, 1989.
- [10] A. Dandridge *et al.*, "Homodyne demodulation scheme for fiber optic sensors using phase generated carrier," *J. of Quantum Elect.*, vol. QE-18, pp. 1647-1653, 1982.
- [11] I. Di Luch *et al.*, "Vibration sensing for deployed metropolitan fiber infrastructures," in *Proc. 2020 Optical Fiber Communications Conference (OFC 2020)*, San Diego, CA, paper 15966, 2020.