

CO<sub>2</sub> from direct air capture as carbon feedstock for Fischer-Tropsch chemicals and fuels: Energy and economic analysis

*Original*

CO<sub>2</sub> from direct air capture as carbon feedstock for Fischer-Tropsch chemicals and fuels: Energy and economic analysis / Marchese, Marco; Buffo, Giulio; Santarelli, Massimo; Lanzini, Andrea. - In: JOURNAL OF CO<sub>2</sub> UTILIZATION. - ISSN 2212-9820. - 46:(2021), p. 101487. [10.1016/j.jcou.2021.101487]

*Availability:*

This version is available at: 11583/2874202 since: 2021-03-12T15:13:34Z

*Publisher:*

Elsevier

*Published*

DOI:10.1016/j.jcou.2021.101487

*Terms of use:*

This article is made available under terms and conditions as specified in the corresponding bibliographic description in the repository

*Publisher copyright*

(Article begins on next page)

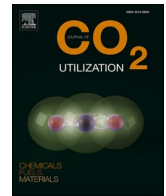

# CO<sub>2</sub> from direct air capture as carbon feedstock for Fischer-Tropsch chemicals and fuels: Energy and economic analysis

Marco Marchese <sup>\*,1</sup>, Giulio Buffo <sup>1</sup>, Massimo Santarelli, Andrea Lanzini

Department of Energy, Politecnico di Torino, Corso Duca degli Abruzzi 24, 10129 Torino, Italy

## ARTICLE INFO

### Keywords:

CO<sub>2</sub> utilization  
Process integration  
Direct air capture  
Fischer-Tropsch  
Techno-economic analysis  
Hydrogen generation

## ABSTRACT

The investigated plant concept integrates the direct air capture technology with the Fischer-Tropsch synthesis. 250 kt/h of air, with a CO<sub>2</sub> concentration of 400 ppm, are used as feedstock to produce the synthetic hydrocarbons. The direct air capture is modelled as a high-temperature calcium recovery loop process. An alkaline electrolyser and a reverse water-gas shift reactor produce the required syngas. The Fischer-Tropsch products distribution is described by a carbide model developed for a Co-Pt/γAl<sub>2</sub>O<sub>3</sub> catalyst for alkanes and alkenes of carbon number C<sub>1</sub>-C<sub>70</sub>. Five integration scenarios are analysed. In the base case, the energy demand of the direct air capture process is supplied with natural gas from the distribution grid. In improved configurations, the effect of Fischer-Tropsch off-gas recirculation to the reverse water-gas shift and/or the direct air capture units is explored, excluding the need of fossil fuel. An electrified direct air capture solution is also included. In the analysed scenarios, the highest system efficiency corresponds to 36.3 %, while the maximum carbon dioxide conversion is of 68.3 %. The maximum waxes production corresponds to 8.7 t/h. Lastly, capital and operating plant costs are allocated in an economic investigation, considering different market electricity costs and financial risk values. In a medium financial risk scenario (interest rate: 7.5 %), the minimum Fischer-Tropsch waxes production cost corresponds to 6.3 €/kg<sub>wax</sub>, reaching 5.05 €/kg<sub>wax</sub> at an interest rate of 0%. Lastly, the effect of learning curves over the production cost at the year 2030 and 2050 is included.

## 1. Introduction

Solutions to reduce CO<sub>2</sub> emissions can involve different portfolios of mitigation measures: lowering energy and resource intensity, increasing the rate of decarbonization, and enhancing the reliance of carbon dioxide removal technologies [1]. In this framework, the European Union has pledged its commitment to achieving climate-neutrality by 2050 [2].

One way to reach such an achievement, is through the utilization of non-fossil carbon sources [3–5]. In non-fossil applications, hydrogen can be produced via electrochemical processes fed by electricity from renewable energy sources (RES). H<sub>2</sub> is then combined with a carbon feedstock to produce synthesis gas, determining the utilization of CO<sub>2</sub> available from a carbon capture process (namely, CCU). The resulting

synthetic gas (i.e., syngas) is further upgraded to synthetic gaseous/liquid fuels and chemicals of practical use and market value [6]. In most of the analyzed scenarios forecasting future net-zero GHG emissions, CCU routes with thermo-/electrochemical processes are expected to play a vital role for the decarbonization of several economic sectors and the increased integration of RES in the electricity generation portfolio and manufacturing [2,6].

For these production chains, ambient air is attracting interest since it might be considered a nearly unlimited CO<sub>2</sub> resource available regardless of the plant location. Hence, research activity has been flourishing in recent years to exploit the carbon content of ambient air through Direct Air Capture (DAC) and reduce the atmospheric CO<sub>2</sub> concentration [7–9]. DAC through sorbent-based processes is studied to increase the removal rate ensured by the natural sinks in carbon cycles and enhance CO<sub>2</sub>

**Abbreviations:** AF, Annuity factor; AFS, Anderson-Flory-Schultz; BEC, Bare erected cost; CAPEX, Capital cost; CC, Combined cycle; CCU, Carbon Capture and Utilization; CEPCI, Chemical Engineering Plant Cost Index; CSP, Concentrated solar power; DAC, Direct air capture; DCF, Discounted cash flow; FCF, Free cash flow; FT, Fischer-Tropsch; HX, Heat exchanger; KPI, Key performance indicators; LCA, Life cycle analysis; LHV, Lower Heating Value; NG, Natural gas; NPV, Net present value; O&M, Operation and maintenance; OG, Off-gas; OPEX, Operating cost; PtL, Power-to-liquid; PV, Photovoltaic; RES, Renewable energy source; RKS, Redlich-Kwong-Soave; RKS-BM, Redlich-Kwong-Soave, with Boston-Mathis modification; RWGS, Reverse water gas shift.

\* Corresponding author.

E-mail address: [marco.marchese@polito.it](mailto:marco.marchese@polito.it) (M. Marchese).

<sup>1</sup> The authors equally contributed to the process model development.

<https://doi.org/10.1016/j.jcou.2021.101487>

Received 28 October 2020; Received in revised form 9 February 2021; Accepted 15 February 2021

2212-9820/© 2021 The Authors. Published by Elsevier Ltd. This is an open access article under the CC BY-NC-ND license

(<http://creativecommons.org/licenses/by-nc-nd/4.0/>).

### Nomenclature

|               |   |
|---------------|---|
| $E_{spCO_2}$  | Specific energy consumption over the CO <sub>2</sub> removed from the air (kWh kg <sub>CO<sub>2</sub></sub> <sup>-1</sup> ) |
| $E_{spwax}$   | Specific energy consumption over the waxes produced (kWh kg <sub>wax</sub> <sup>-1</sup> )                                  |
| $i$           | Interest rate   |
| k-year        | k-th operational year   |
| $\dot{m}$     | Mass flow rate (kg h <sup>-1</sup> )  |
| $n$           | Scaling factor  |
| $\dot{n}$     | Molar flow rate (mol s <sup>-1</sup> )  |
| $\eta_{life}$ | Plant lifetime  |
| $Q_{th}$      | Thermal power (kW)  |
| $S_i$         | Size of the system component  |
| $W_{el}$      | Electric power (kW)   |
| $\Delta H$    | Enthalpy change   |
| $\eta_C$      | Carbon conversion efficiency  |
| $\eta_{CO_2}$ | Carbon dioxide removal efficiency   |
| $\eta_{GI}$   | Plant global efficiency   |

mitigation. For DAC applications, chemical sorbents are required to effectively capture CO<sub>2</sub>, given its low concentration in ambient air [10]. Causticization with alkali and alkali-earth aqueous hydroxide sorbents [11], solid alkali carbonates [12] and organic-inorganic hybrid sorbents [10] are possible options to capture CO<sub>2</sub> from the air through reversible chemisorption.

The captured molecules can be used as raw material into carbon capture and utilization routes, producing several synthetic products [13], including Fischer-Tropsch (FT) material. CO<sub>2</sub> can be combined with H<sub>2</sub> or steam to form syngas via electrochemical or thermochemical catalytically driven processes [14]. Exothermic hydrogenation of CO to synthetic hydrocarbons inside the FT reactor is then applied [15]. The resulting products comprise of alkanes, alkenes and alcohols in gas, liquid, and wax phases. The advantage of the FT synthesis is the capability of targeting multiple hydrocarbons, with carbon numbers from C<sub>1</sub> to C<sub>100+</sub> [16]. Specifically for high molecular weight products, the source is usually of fossil form. Therefore, the synthesis of long-chain FT hydrocarbons from CO<sub>2</sub> becomes strategic to reduce the consumption of fossil material not only in the transport sector but also in the chemical sector [17,18].

Much research effort has been spent in recent years in designing and demonstrating the integration of DAC into CCU routes. The Soletair project [19] and the Kopernikus Project [20] are examples of applications to synthesize FT products from air CO<sub>2</sub>. Although these represent small-scale pilot applications, they are promising in establishing the effectiveness of this route. As reported in Table 1, most of the literature works on DAC-to-FT mainly deal with the life-cycle analysis (LCA) and the economic feasibility of the process, and the assessment of its role in current and future economic scenarios. For instance, Viebahn et al. [21] explored the possible role of the DAC into the German technology portfolio, through a multi-dimensional analysis to highlight the research needs that this technology still demands. The authors presented the best practices for DAC integration with several downstream technologies. However, their work was not focused on modeling, nor energy analysis. In the configuration of the FT route, they used exogenous productivity data from existing operating plants, without modeling information. van der Giesen et al. [22] investigated the LCA of solar liquid FT fuels production, comparing their environmental impact against their fossil counterparts. The FT reaction kinetics was not implemented in the study and the two sections of the scheme were not integrated into mass nor thermal terms. Fasihi et al. [23–25] investigated the production of FT fuels in a cost-optimized power-to-liquid routes, exploiting CO<sub>2</sub> from the air and a hybrid PV-wind power plant. The authors included a

recirculation of the FT off-gas to produce electric energy in a combined cycle gas turbine to sustain the endothermicity of an electrified RWGS reactor. Contrarily to the present model, they employed a DAC section based on the solid sorbent technology and utilized clustered data for the FT products distribution taken from literature. Recently, Liu et al. [26] focused on the LCA of a high temperature DAC system paired with an FT unit to produce transportation fuel (i.e., diesel). The analysis was based on data and models from other works (e.g., Mansouri et al. [27] for the simplified FT synthesis power-law description and Keith et al. [28] process data for the DAC unit). Nonetheless, the authors highlighted the need for extensive DAC-FT matching analyses to maximize emissions reductions, as the focus of their study was not on the process integration.

In our work, we provide a detailed assessment on the techno-economic performance of a DAC-to-FT CCU plant. By means of process and energy integration, we identify the most suitable configuration to maximize CO<sub>2</sub> conversion into synthetic chemical and fuel feedstocks. Hence, the present work provides new and novel results on the DAC-to-FT route, filling the gap of system matching investigation. Firstly, the integrated DAC-to-FT process model is presented. Five separate configurations based on different FT off-gas recirculation solutions are studied, including detailed energy and mass integrations and the evaluation of key performance indicators (i.e., the specific energy consumption of carbon capture and conversion, carbon removal efficiency, system global efficiency). A solution with an electrified high temperature DAC section is also investigated. Secondly, a detailed mechanistic kinetic model describing the FT product distribution up to carbon number C<sub>70</sub> is adopted. This allows identifying the plant design that synthesises the highest quantity of heavy hydrocarbons (i.e., wax fraction) while maximizing the CO<sub>2</sub> removal rate from the air and studying the effect of each plant configuration on the FT products distribution. Lastly, economic considerations are provided to estimate the cost of FT waxes production under each plant design. Sensitivities over the interest rate, the cost of electricity from different renewable energy sources and carbon credits solutions are provided. Additionally, learning curves estimation at the year 2030 and 2050 provide the evolution of the cost of production of FT waxes over the next decades with this route. Thus, this work represents a milestone in the development of highly integrated plants to produce synthetic FT material from the air, and represents the first investigation in terms of FT wax production costs from air CO<sub>2</sub>.

## 2. Methods

The proposed system comprises of three main blocks: the capture of CO<sub>2</sub> from ambient air; the generation of syngas; the FT reaction for the synthesis of hydrocarbons. The process developed in this study is depicted in Fig. 1. The mass and energy balances of the different sections and the thermodynamic transformations of the operating streams were obtained using the commercial process simulator Aspen PLUS™. Large-scale data based on the DAC process proposed by Keith et al. [28] for the recovery of carbon dioxide from ambient air are used. The DAC system is connected to a reverse water-gas shift (RWGS) and an FT reactor. Moreover, in compliance with the model of Keith et al. [28], a natural gas (NG) turbine is used to meet the DAC section electric needs. NG is also fed to the DAC calciner reactor to meet its thermal needs. The process is studied under five plant designs, in terms of FT products synthesis and distribution, plant efficiency and carbon removal efficiency. The base process design considers NG supplied to the gas turbine and calciner, with FT off-gas recirculated to the RWGS (C.1). The upgraded configurations contemplate the avoidance of fossil natural gas, with recirculation of part of the FT off-gas to the DAC unit (configuration C.2), or to both the DAC and the RWGS (configuration C.3). Additionally, configurations C.4 and C.5 exclude the use of the power island, with C.4 having an electrified calciner, and C.5 utilizing the FT off-gas to the calciner. More details are found in section 2.4.

**Table 1**

Literature articles on DAC-FT processes and position of our research work compared to study objective, type of DAC and FT units, and application of recirculation of the FT off-gas.

| Ref.                | Study Objectives  | DAC-section  | FT-section  | FT off-gas recirculation   |
|---------------------|---|--|---|--|
| [19]                | Results of a pilot plant within the Finnish national project SOLETAIR   | Low-T Hydrocell-based technology   | Experimental distribution   | Not included, suggested within the SOLETAIR Project  |
| [29]                | Assessment of combustion properties of FT fuels for aviation  | Not modelled – mentioned among the CO <sub>2</sub> sources for the Kopernikus Project  | Experimental distribution   | FT off-gas recycle possibility to the RWGS - not modelled  |
| [22]                | LCA for Liquid FT fuels, using different carbon sources   | Low-T, model after [30]  | No kinetic model, Shell FT reactor data   | Not included, off-gas assumed for steam generation and mild heat recovery from FT to RWGS catalyst regeneration. No integration to the DAC unit                                    |
| [31]                | LCA and economic assessment for FT jet fuels  | Low-T Climeworks-based technology (no model, only energy consumption)  | Not modelled. Only assumed 90 % syngas-to-hydrocarbon conversion  | Not included nor discussed. Only water recycle   |
| [32]                | LCA and economic assessment for FT fuels in 2015/2030   | Low-T Climeworks/Lackner et al. for CO <sub>2</sub> cost. Not modelled   | Not modelled. Literature-based syngas-to-hydrocarbon conversion of 71 %   | Not included   |
| [33]                | Assessment of combustion processes and emission of e-fuels (FT/OMeX) and LCA when using CO <sub>2</sub> from DAC  | N.A.-not modelled  | N.A. Evaluation of fuels from tanks   | Included only as exhaust gas recirculation - not intended as FT production yield increment   |
| [26]                | LCA for liquid FT transportation fuels w/ sensitivity on the carbon intensity of electricity source   | High-T C.E.-based technology and model   | Simple power-law kinetic model [27]. No FT products full distribution description                                       | Not included, off-gas assumed for steam generation and CHP. Only sensitivity on the H <sub>2</sub> /CO and FT temperature. No detailed information on the FT products distribution |
| [34, 35]            | Review, Environmental and Techno-Economic assessment of PtL routes (MeOH/FT)  | Low-T, Climeworks-based technology   | FT process based on literature data. Not modelled   | Not included   |
| [21]                | Best practices for DAC integration into the German's technology horizon   | Multiple technologies accounted  | Productivity data from operating plants/pilot plants. Not modelled  | Not included. Detailed integrated energy model not a study goal  |
| [36]                | Review article of the CO <sub>2</sub> conversion through FT   | –  | –   | Mentioned within SOLETAIR Project description but not discussed  |
| [37]                | Review of CO <sub>2</sub> recycling pathways, techno-economic analysis for the production of synthetic fuels from CO <sub>2</sub> captured from the air and solid oxide co-electrolysis to Fischer-Tropsch. | Solid sorbent DAC at low-T operations (45 °C). Black box with energy consumption and CO <sub>2</sub> stream cost   | State-of-the-art High Temperature Fischer-Tropsch technology (300 °C), not modelled with detailed products distribution | Recovery of heat from the Fischer-Tropsch reactor. No information provided over FT off-gas recirculation   |
| [23,24, 25, 38, 39] | TEA forecast scenarios for transportation fuels production (including FT-derived fuels) based on cost-optimized renewable power plants and capture of CO <sub>2</sub> from the air technologies.            | Low-T DAC unit accounting for energy and costs related to the Climeworks technology  | Low-Temperature Fischer-Tropsch unit with mass share of clustered products based on literature data.                    | Account for heat and mass integration. Recirculation of the FT off-gases is studied towards a combined cycle gas turbine to sustain an electrified RWGS                            |
| [25]                | Report on the cost of liquid fuels based on the MeOH and FT technologies utilizing CO <sub>2</sub> from the air in the country of Germany   | Description and energy/economic data based on Climeworks low-T configuration   | Fischer-Tropsch description based on literature data [24,25].   | Not mentioned, but most likely accounted as off-gas recirculation for electric generation based on literature studies [24, 25].  |
| [40]                | Description of the Direct Air Capture technology as a key technology to produce carbon-based materials (minerals and fuels)   | Low-T technology based on Climeworks application   | Not described, only mentioned for transportation fuels productions.   | Not included   |
| [41]                | Production of FT syn crude based on either biomass gasification or DAC fed with intermittent RES coupled with CO <sub>2</sub> storage unit  | Modelling of the DAC not provided  | Fischer-Tropsch model based on experimental data on a commercial catalyst [42]  | Not included   |
| [43]                | Techno-economic assessment with forecast scenarios of kerosene production in Germany, exploiting CO <sub>2</sub> from air, biomass, and CO <sub>2</sub> from flue gases as carbon feedstocks                | Both the DAC and the FT performance and cost data are taken from literature works. No information about modelling, mass and energy integration, nor recirculation if provided. |   |  |
| [44]                | Review of PtL technologies (reactors and materials, production costs) for the production of MeOH, DME, and FT fuels from air CO <sub>2</sub> capture with DAC technology                                    | Description of DAC technologies and their applications in PtL routes   | Description of FT reactors and products share   | Not included   |
| [45]                | Evaluation of production cost of synthetic liquid hydrocarbons based on different CO <sub>2</sub> sources (industry, air, biomass), most profitable production chains, and allocation of end-products       | Literature data based on unspecified DAC cost configuration projected to the year 2050   | Literature data [34]  | –  |
| This study          | DAC + FT energy and mass integration for enhanced wax production yield and economic evaluation. Effect of process configuration on the FT products distribution   | High-T C.E.-based technology and model   | Detailed mechanistic kinetic model, describing the full FT products distribution  | In-depth analysis to evaluate the best recirculation design of the FT gas fraction for enhanced wax production and CO <sub>2</sub> mitigation potential                            |

### 2.1. Direct air capture

The process of DAC was modelled taking the cue from a reference layout based on calcium recovery loop, similar to the work proposed by Keith et al. [28]. The process chemistry is described by the following reactions:

In the DAC section, two separate loops are identified: the first one

comprising of an air contactor, an absorber column, and a pellet reactor for CO<sub>2</sub> capture; the second one involving the pellet reactor, a cyclone, a washer, a slaker and a calciner reactor. In the air contactor, CO<sub>2</sub> (400 ppm in air) was removed from ambient air through an aqueous alkali solution of 1.0 mol OH<sup>-</sup>, 0.5 mol CO<sub>3</sub><sup>2-</sup> and 2.0 mol K<sup>+</sup> yielding K<sub>2</sub>CO<sub>3(aq)</sub>. The capture rate of this component was set to 75 % of CO<sub>2</sub> in the form of K<sub>2</sub>CO<sub>3(aq)</sub> [28]. Similarly, 90 % of the CO<sub>2</sub> contained in the

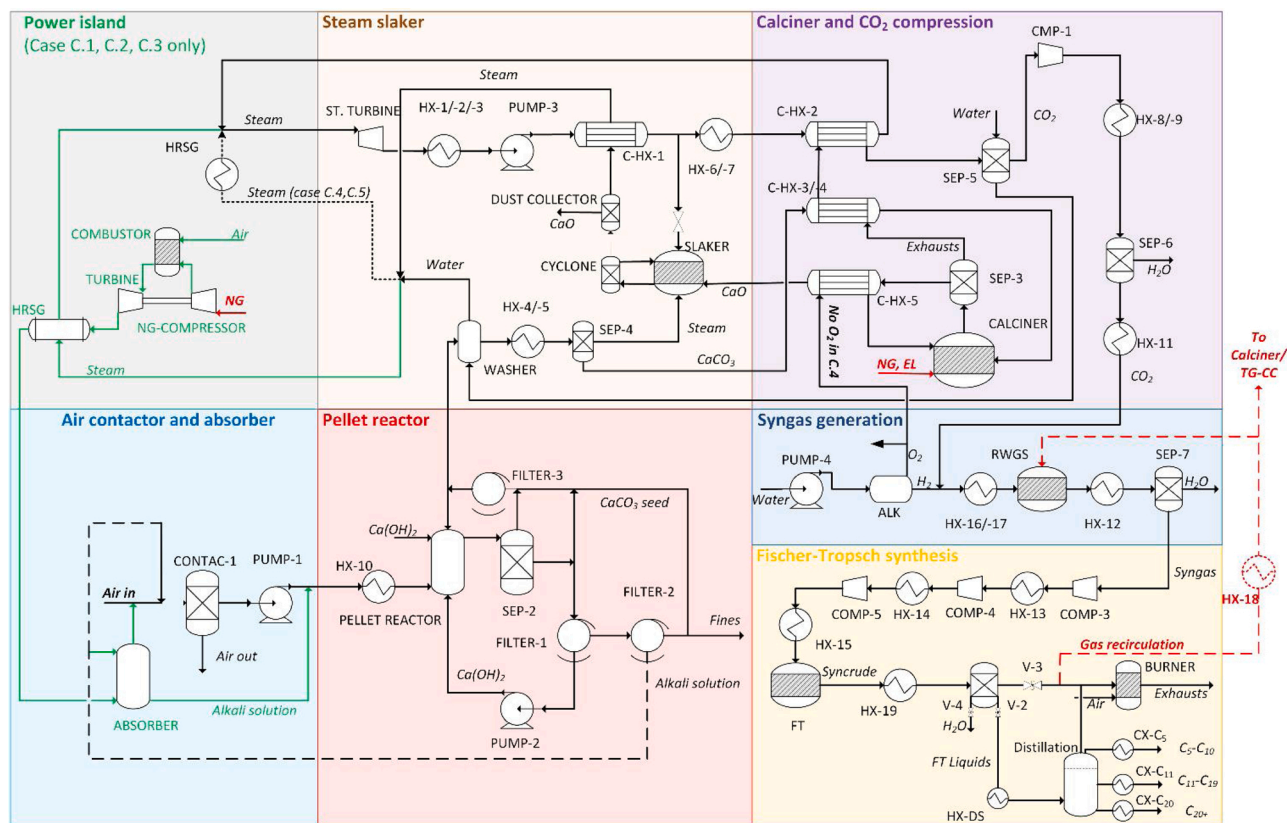

**Fig. 1.** Proposed DAC-FT system. Only the baseline configuration (C.1) presents natural gas fed to the DAC. For configurations C.1, C.2, and C.3 there exists a power island (highlighted with green solid lines and text), which is excluded in configurations C.4 and C.5.

exhausts leaving the combined cycle was absorbed in a packed column (absorber). The stripped-off gas was mixed with ambient air. The calcium loop regenerated the alkali capture solution through the precipitation of  $\text{CO}_3^{2-}$  reacting with  $\text{Ca}^{2+}$  of  $\text{Ca}(\text{OH})_2$  in the pellet reactor, forming  $\text{CaCO}_3$  via reactions 5–6 (Table 2). This pellet reactor was simulated with a crystallizer reactor component of Aspen PLUS<sup>TM</sup> implementing reactions 5–10, ensuring calcium retention equal to 90 % (i.e., the share of injected calcium leaving the reactor as pellets rather than being disposed of as fines) [28]. The precipitation of calcium carbonate pellets is adapted from a fluidized-bed crystallizer commercialized by RHDHV [46] used also for DAC applications. The  $\text{CaCO}_3$  pellets were washed, dried, heated up and entered an oxygen-fired calciner (95.6 %  $\text{O}_2$ , 4.4  $\text{N}_2$ ) with a  $\text{CaCO}_3$ -to- $\text{CaO}$  conversion efficiency equal to 98 %. Finally, the concentrated stream of  $\text{CO}_2$  leaving the calciner was washed in a water knockout and fed to the RWGS reactor. The complete combustion of NG in the calciner thermally sustained the endothermic decomposition of  $\text{CaCO}_3$  pellets, thus providing adiabatic operations in the calciner. The stoichiometric reactor for the  $\text{CaO}$  hydration in the steam slaker was fed by a fraction of the steam in the bottom cycle of the

combined cycle. A primary cyclone elutriated and recirculated small  $\text{CaO}$  particles to the slaker. The further  $\text{CaO}$  particles collected in the downstream dust collector can be disposed of or reused: their end of life is out of the scope of this study, but suggested to assess the potential savings of raw material and energy. The output  $\text{Ca}(\text{OH})_{2(\text{aq})}$  was then fed to the pellet bed to react with  $\text{K}_2\text{CO}_3$ . Table S.1 in supporting material reports the specifications of the DAC main blocks.

The properties and thermodynamic parameters of the chemical components were estimated with the unsymmetrical electrolyte non-random two-liquid method (for the liquid phase), Redlich-Kwong equation and Henry's Law for gas phase and Vapor-Liquid Equilibrium. In two-phase blocks, the mass transfer was modelled with a "two-film" rate-based approach neglecting the mixing by convection [47,48].

## 2.2. Syngas generation

The syngas, a mixture of  $\text{H}_2$ ,  $\text{CO}$ ,  $\text{CO}_2$ , and  $\text{H}_2\text{O}$ , was yielded at the RWGS reactor outlet and compressed to the operating pressure of the FT reactor.

### 2.2.1. Hydrogen generation

The required hydrogen was obtained through electrolysis of water in a low-temperature alkaline electrolyser. The electrolyser operated at ambient pressure and 60 °C and consumed 15  $\text{L}_{\text{H}_2\text{O}}/\text{kg}_{\text{H}_2}$  and 52  $\text{kWh}_{\text{el}}/\text{kg}_{\text{H}_2}$  [49], resulting in a absorbed power ranging between 646 and 858  $\text{MW}_{\text{el}}$ . The electric input to run the electrolysis process was assumed to be of renewable energy source (e.g., hydro, PV, wind, etc.), hence not affecting the carbon balance with indirect emissions associated to power generation. Balancing renewable energy production mismatch with the electrolysis power demand through a dynamic charging/discharging schedule of hydrogen storage is out of the scope of this work. Oxygen was considered as an electrolyser by-product, and a fraction of it was fed

**Table 2**  
DAC unit chemical reactions.

| Reaction   | Type         | Reaction   | Type         |
|--|--------------|--|--------------|
| 1) $\text{H}_2\text{O} + \text{HCO}_3^- \leftrightarrow \text{CO}_3^{2-} + \text{H}_3\text{O}^+$ | Equilibrium  | 6) $\text{K}_2\text{CO}_3(\text{s}) + \text{CO}_3^{2-} + 2 \text{K}^+$     | Salt precip. |
| 2) $\text{CaOH}^+ \leftrightarrow \text{Ca}^{2+} + \text{OH}^-$                                  | Equilibrium  | 7) $\text{CaCO}_3 \leftrightarrow \text{CO}_3^{2-} + \text{Ca}^{2+}$       | Salt precip. |
| 3) $2\text{H}_2\text{O} + \text{CO}_2 \leftrightarrow \text{HCO}_3^- + \text{H}_3\text{O}^+$     | Equilibrium  | 8) $\text{KOH}(\text{s}) \leftrightarrow \text{OH}^- + \text{K}^+$         | Salt precip. |
| 4) $2\text{H}_2\text{O} \leftrightarrow \text{OH}^- + \text{H}_3\text{O}^+$                      | Equilibrium  | 9) $\text{K}_2\text{CO}_3 \leftrightarrow \text{CO}_3^{2-} + 2 \text{K}^+$ | Dissociation |
| 5) $\text{Ca}(\text{OH})_2 \leftrightarrow \text{CaOH}^+ + \text{OH}^-$                          | Salt precip. | 10) $\text{KOH} \leftrightarrow \text{OH}^- + \text{K}^+$                  | Dissociation |



to the calciner reactor to sustain the process of oxy-combustion and ensure adiabatic operation.

### 2.2.2. Reverse water-gas shift

CO<sub>2</sub> coming from the DAC unit was mixed with H<sub>2</sub> and preheated to 550 °C before entering the RWGS reactor operating at ambient pressure and 800 °C. The generated syngas had the desired H<sub>2</sub>/CO outlet molar ratio of 2.0. The RWGS operated at equilibrium conditions, employing a Ni-Al<sub>2</sub>O<sub>3</sub> catalyst [50], and described with Redlich-Kwong-Soave (RKS) equation of state. The conversion of CO<sub>2</sub>-to-CO followed reaction 11 of Table 3, determining the high endothermicity of the reactor. In parallel, side reactions of methanation (12–13), Boudouard reactions (14–15), hydrocarbon cracking (16–17) were considered.

### 2.3. Fischer-Tropsch

A low-temperature FT reactor was operated at 230 °C and 25 bar. It converted the feed of syngas into synthetic hydrocarbons via catalytically driven reactions of CO with H<sub>2</sub>. The syngas was compressed to the operating pressure before the FT reactor. A mechanistic carbide kinetic model for a Co-Pt/ $\gamma$ -Al<sub>2</sub>O<sub>3</sub> catalyst was used to describe the production rate of the FT reactor [51]. The kinetic model was inserted in the process simulator via an external subroutine. The simplified chemical reactions are presented in Table 4. Thanks to the application of detailed kinetic model, each product generation rate and reactant consumption rate were accounted for. The distribution of the FT products followed a modification of the Anderson-Flory-Schultz (AFS) distribution, where a higher CH<sub>4</sub> generation, a lower C<sub>2</sub>H<sub>4</sub> generation and a linearization of the curve for carbon numbers higher than C<sub>20</sub> were obtained with respect to the AFS theory. A per-pass CO conversion of 75 % was assumed [52]. The products leaving this reactor comprised unreacted CO<sub>2</sub>, CO and H<sub>2</sub>, steam and alkanes and alkenes synthesised up to carbon number C<sub>70</sub> and carbon number C<sub>40</sub>, respectively. A three-phase (liquid-liquid-gas) separator operating at the FT pressure and ambient temperature separated the FT off-gas (CO, H<sub>2</sub>, CO<sub>2</sub> and mainly light hydrocarbons up to carbon number C<sub>6-7</sub>), the liquid products and water. The liquid products were preheated to 230 °C and further separated into a distillation column based on their boiling temperatures as naphtha (120 °C, C<sub>5</sub>-C<sub>11</sub>), middle distillates (225 °C, C<sub>11</sub>-C<sub>20</sub>) and waxes (380 °C, C<sub>20</sub>-C<sub>70</sub>). The liquid products were used to account for the energy performance of the full plant. The FT reactor used the RKS equation of state, with Boston-Mathis alpha-value modification. More details can be found at [52].

### 2.4. Plant upgrading and thermal integration

The recirculation of the FT off-gas can provide a variation in plant productivity and efficiency [53]. Additionally, they can be used as a solution to avoid feeding fossil natural gas to the system. Therefore, four additional plant designs were studied in this analysis. These configurations are presented in Fig. 2.

- Configuration C.1: the FT off-gas were recirculated at the RWGS reactor inlet. The recirculated stream included unreacted CO<sub>2</sub>, H<sub>2</sub>,

**Table 3**  
RWGS reactor chemical reactions.

| Reaction   | $\Delta H_{298K}^0$ [kJ/mol] | Reaction  | $\Delta H_{298K}^0$ [kJ/mol] |
|--|------------------------------|---|------------------------------|
| 11) CO <sub>2</sub> +H <sub>2</sub> ↔ CO+H <sub>2</sub> O <sub>(v)</sub>                 | +41                          | 15) 2 CO+H <sub>2</sub> ↔ H <sub>2</sub> O <sub>(v)</sub> +C <sub>(s)</sub>                     | -131                         |
| 12) CO+3H <sub>2</sub> ↔ CH <sub>4</sub> +H <sub>2</sub> O <sub>(v)</sub>                | -165                         | 16) C <sub>n</sub> H <sub>m</sub> ↔ nC+(m/2)H <sub>2</sub>                                      | e.g. +791 CH <sub>4</sub>    |
| 13) CO <sub>2</sub> +4H <sub>2</sub> ↔ CH <sub>4</sub> +2H <sub>2</sub> O <sub>(v)</sub> | -206                         | 17) C <sub>n</sub> H <sub>m</sub> +nH <sub>2</sub> O <sub>(v)</sub> ↔ nCO+(n+m/2)H <sub>2</sub> | e.g. +206 CH <sub>4</sub>    |
| 14) 2CO ↔ CO <sub>2</sub> +C <sub>(s)</sub>  | -172                         |   |                              |

**Table 4**  
FT reactor chemical reactions.

| Reaction   | $\Delta H_{298K}^0$ [kJ/mol] |
|--|------------------------------|
| 18) CO+2H <sub>2</sub> ↔ -(CH <sub>2</sub> )-+H <sub>2</sub> O                     | -165                         |
| 19) nCO+(2n+1)H <sub>2</sub> ↔ C <sub>n</sub> H <sub>2n+2</sub> +nH <sub>2</sub> O | Paraffins                    |
| 20) nCO+(2n)H <sub>2</sub> ↔ C <sub>n</sub> H <sub>2n</sub> +nH <sub>2</sub> O     | Olefins                      |

CO and CH<sub>4</sub>, and other light hydrocarbons in a lower concentration. These underwent steam reforming according to reaction 17, increasing the yield of syngas production. NG was fed to the DAC section, in accordance with the DAC configuration proposed by Keith et al. [28].

- Configuration C.2: the FT off-gas were recirculated to the DAC, substituting the NG stream. CH<sub>4</sub> and light hydrocarbons underwent oxy-combustion inside the calciner reactor and combustion inside the combined cycle. The fraction of off-gas recirculated to the combined cycle allowed covering the electric needs of the DAC system, while the remaining flow ensured adiabatic operations of the calciner reactor.
- Configuration C.3: the FT off-gas were recirculated to the RWGS reactor inlet and DAC unit. The off-gas recirculated to the DAC unit were distributed to both the combined cycle and calciner with the same criterion as in configuration C.2.
- Configuration C.4: the FT off-gas is recirculated to the inlet of the RWGS reactor. The combined cycled and the absorption column are excluded from the DAC section, and the calciner is electrically heated.
- Configuration C.5: even in this case the combined cycle and the absorption column are excluded from the model, and the calciner heat is provided by partial recirculation of the FT off-gas. The remaining part of the FT off-gas is fed to the RWGS reactor.

Under all configurations, a fixed electric output of 30 MW<sub>el</sub> from the combined cycle turbine was assumed. Moreover, the airflow to the combined cycle compressor for case C.1, C.2, and C.3 was iteratively changed to reach an absorber column inlet temperature of 93 °C [28].

Concerning the possible issue of resource availability, the process uses natural gas in C.1, for which it may not be installed anywhere; thus, our study assessed four designs (C.2 to C.5) that do not require any feed of natural gas to the calciner nor the combined cycle in the DAC section. These configurations are completely decoupled from the natural gas infrastructure, hence without any restriction about the installation site from this standpoint. Additionally, they allow having a solution where the only carbon source is the air. Concerning water consumption, this cannot be avoided since water is the essential feed stream for hydrogen production through electrolysis and is also used in the knockout section. Hence, it is worth remarking that water availability is extremely important when assessing the techno-economic feasibility of this technology and its integration in local contexts.

In any recirculation solution, a minimum value of 5% of the FT off-gas was fed to the burner at the FT separation unit outlet, avoiding the accumulation of inert gases in the plant lines [54]. The off-gas percentage sent to the RWGS in configurations C.3 and C.5 was evaluated accordingly:

$$OG\%_{RWGS} = 95\% - (OG\%_{C.Cycle} + OG\%_{Calciner}) \quad (1)$$

With the value to the combined cycle equal zero in C.5. NG had a composition of CH<sub>4</sub>/C<sub>2</sub>H<sub>6</sub>/CO<sub>2</sub>/N<sub>2</sub>: 89/4/3/4mol-%. Finally, endothermicity and exothermicity of the different plant components were exploited to reduce the total plant thermal needs. The pinch analysis methodology was applied, identifying the optimal energy integration of the whole plant under each configuration.

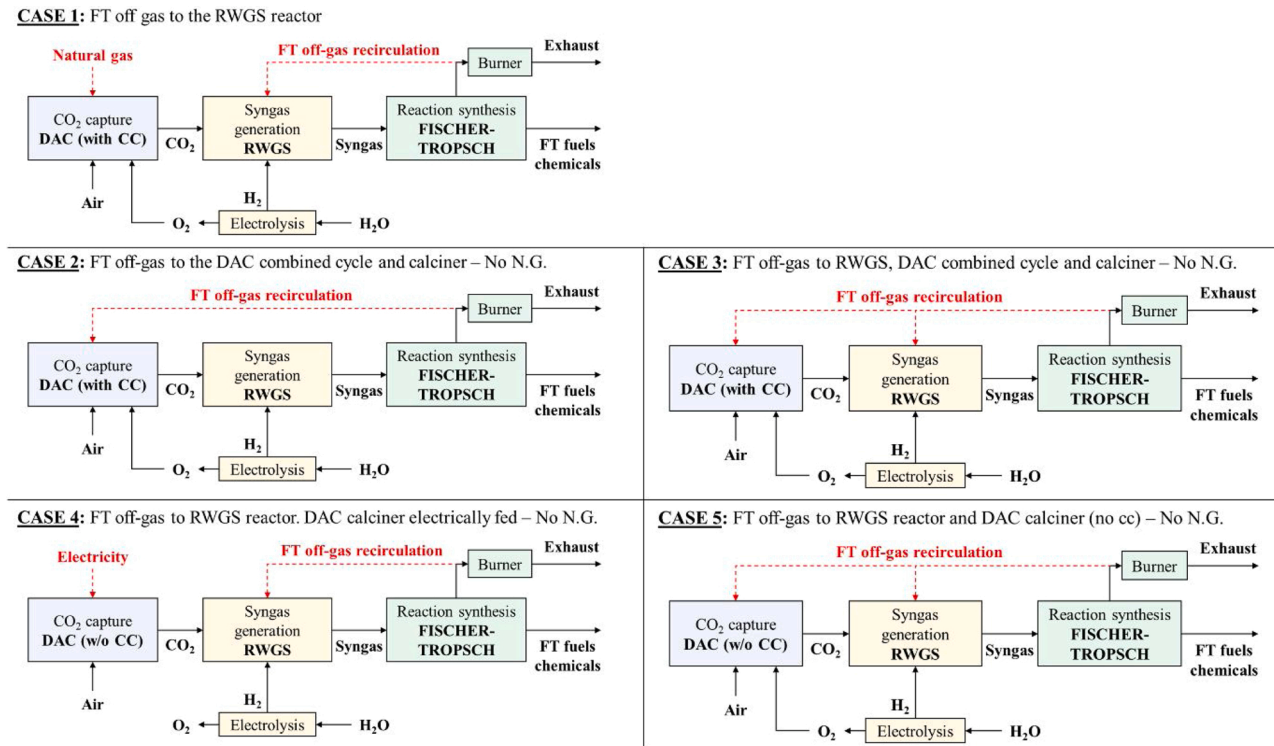

Fig. 2. Configurations studied in this work. Recirculation options are highlighted with red-dashed lines.

## 2.5. Economic assessment

To complete the investigation, an economic assessment was included. Starting from the mass and energy balances, the capital cost (CAPEX) and the annual operating costs (OPEX) of each system were computed, assuming:

- 8,000 operating hours per year;
- plant lifetime of 25 years;
- 2019 as the year for cost estimations (Chemical Engineering Plant Cost Index, CEPCI: 619 [55]);
- Costs in euros, at an exchange rate \$/€ of 1.145 when applied;
- no remuneration of invested capital;
- nor depreciation nor taxes, to be as more site-independent as possible.

The investment cost of the system was computed starting from exogenous data found in literature, adopting a top-down approach:

- for the DAC subsystem, a unit capital cost of 733 €/t<sub>CO<sub>2</sub></sub> y was assumed, actualizing the value provided by Fasihi et al. [9] for the installation of the N-th DAC plant and referred to an estimate by Carbon Engineering [56], including direct field costs, non-field costs and indirect costs. For the electrified configuration C.4 and configuration C.5 without combined cycle a cost of 562 €/t<sub>CO<sub>2</sub></sub> y and 549 €/t<sub>CO<sub>2</sub></sub> y for the N-th DAC installed unit was assumed, respectively [9].
- The bare erected cost (BEC) of the heat exchanger was assessed as a function of their power (S, in kW) [57]:

$$BEC_{HX} = 1.3 \cdot 144 \left( \frac{S}{150} \right)^{0.78} \quad (2)$$

where 144 k€ (2019, i.e., 130 k€ in 2015) is the bare module cost of a 150-kW heat exchanger and 1.3 is the installation factor. Indirect costs were assessed as half of the bare module cost [57]. This cost function is

in good agreement with the one provided by Atsonios et al. [58] for large-size heat exchangers.

- For an alkaline electrolyzer (including the stack, power converters, water purification system, gas purification unit and water recirculation pump) with a nominal size equal to  $P_{WE}$  (kW), the following function fitting the data reported in [59] was derived:

$$\tilde{c}_{BM, WE} \left[ \frac{\text{€}}{\text{kW}} \right] = 1437 \cdot P_{WE}^{-0.095} \quad (3)$$

- The RWGS, the syngas compressors, the burner and the distillation column costs were evaluated utilizing eq. 4, as follows:

$$C_i = C_{ref, i} \left( \frac{S_i}{S_{ref, i}} \right)^n \left( \frac{CEPCI_{2019}}{CEPCI_{ref, i}} \right) \quad (4)$$

Being S and  $S_{ref}$  the model and reference size of the i-th component according to Table 5, C and  $C_{ref}$  the capital cost of the i-th component.

- Decker et al. [63] provided a linear cost function for the FT system, with a specific capital cost of 530 €/kW and an installation factor equal to 2.

The sum of the capital costs after contingencies and installation factors of the different sections represented the plant CAPEX, assuming a confidence range of the investment costs as  $\pm 30\%$  [64].

Table 5

Cost parameters used for the RWGS, syngas compression, FT products distillation column and burner.

| Element             | n    | $S_{ref}$ | $C_{ref}$ | Ref. |
|---------------------|------|-----------|-----------|------|
| Burner              | 0.80 | 20.00 MW  | 1.97 M€   | [60] |
| Syngas Compressor   | 0.68 | 0.413 MW  | 0.49 M€   | [60] |
| Distillation Column | 0.70 | 6.590 t/h | 0.73 M\$  | [61] |
| RWGS                | 0.65 | 43.00 t/h | 32.0 M\$  | [62] |

The operating costs of the system were allocated to the different sections according to Table 6, which included electrical and non-electrical related costs derived from the systems operations. Catalysts replacements in the reactors were assumed every 3 years of operations [64].

For the electrolyser replacement, we have assumed its substitution every 10 years, with a direct dependency over the capacity of the device, according to the following equation [66]:

$$Alk_{Repl.} \left[ \frac{\text{€}}{\text{kW}} \right] = \frac{2}{3} 0.4 Alk_{Capex} \quad (5)$$

Moreover, the sensitivity of the power-related OPEX (i.e., sensitivity over the electric costs) to the market price of electric energy from different renewable sources was assessed, considering the global-weighted costs valid in 2019 and taken from [68]:

- 41.05 €/MWh hydropower;
- 46.29 €/MWh – onshore wind;
- 59.39 €/MWh – PV;
- 63.76 €/MWh – geothermal;
- 100.44 €/MWh – offshore wind;
- 158.95 €/MWh – CSP (concentrated solar power).
- 210.00 €/MWh – Baseload electricity from hybrid PV-wind power plant [69].

Among the selected sources, hydropower can be considered the cheapest solution, but also constrained to resource availability throughout the year. Additionally, such a resource might be used for direct power demands, rather than being utilized in CCU routes. However, studies assessing the production of synthetic fuels and hydrogen with hydropower are available from the open literature [70,71], with the possibility of also matching power production and demand [72]. Moreover, the use of direct renewable energy might be non-trivial and affected by fluctuation and location, with the need of expensive hydrogen storage solutions at 470 €/kg<sub>H2</sub> [49] (e.g., in PV or wind applications). Hence, baseload operations were also considered, as high capacity CCU plants for synthetic hydrocarbons can be connected to the electric grid supposing a feed of mixed renewable energy sources [69]. Adopting such a solution, might not represent cost-optimized values, depending on the site of installation.

The systems revenues were derived considering the sale of residual oxygen from the steam electrolysis not consumed internally to the system (sale value €/kg<sub>O2</sub> 0.15 [73,74]) and the FT products of carbon number C<sub>5</sub>-C<sub>20</sub> separated from the resulted heavy wax fraction (i.e., naphtha at 0.31 \$/l and middle distillates at 0.5 \$/l [67]).

The discounted cash flow analysis [75] was performed considering

**Table 6**

Operating costs of the different sections of the system. <sup>a</sup>Reference to the section CAPEX. <sup>b</sup>Includes syngas compression, products distillation, and off-gas combustor.

| OPEX                                  | Value   | Ref.          | DAC | Alk | HEN | RWGS | FT <sup>b</sup> |
|---------------------------------------|---------|---------------|-----|-----|-----|------|-----------------|
| <b>Non-electric costs</b>             |         |               |     |     |     |      |                 |
| O&M (% CAPEX <sup>a</sup> )           | 3.70    | [9]           | X   | X   | X   | X    | X               |
|                                       | 3.00    | [60,61,62,65] |     |     |     |      |                 |
| Water consumption (€/m <sup>3</sup> ) | 0.09    | [56]          | X   | X   | X   |      |                 |
| Alk. repl. every 10 years (k€/kW)     | Eq. (5) | [66]          |     | X   |     |      |                 |
| Cat. repl. every 3 years (%)          | 1.00    | [64]          |     |     |     | X    |                 |
| Cat. repl. every 3 years (€/kg)       | 112.9   | [67]          |     |     |     |      | X               |
| NG to CC/calcliner (€/MWh)            | 11.3    | [56]          | X   |     |     |      |                 |
| <b>Electric costs</b>                 | –       |               | X   | X   | X   |      | X               |

three values of the interest rate to account for different levels of investment risks ( $i = 0\%$  - low risk;  $i = 7.5\%$  - medium risk;  $i = 12.5\%$  - high risk), assuming total capital expenditure at year 0 [56]. The cash flow at the  $k^{\text{th}}$  year consists of the sum of the operating costs:

- Free Cash Flow:

$$FCF_k = OPEX_k - Revenue_k \quad (6)$$

- Discounted Cash Flow:

$$DCF_k = \frac{FCF_k}{(1+i)^k} \quad (7)$$

- Net present value, i.e. the total money flow during the plant lifetime ( $n_{lfe}$ ):

$$NPV = CAPEX + \sum_{k=1}^{n_{lfe}} DCF_k \quad (8)$$

Lastly, at each interest rate value, the cost of Fischer-Tropsch waxes production was assessed [€/kg<sub>wax</sub>], considering as lower and upper boundaries the electricity generation costs of hydropower and CSP sources, respectively:

$$Wax\ cost = \frac{NPV}{\dot{m}_{wax,out} \cdot AF} \quad (9)$$

where  $\dot{m}_{wax,out}$  is the wax mass flow rate. AF is the annuity factor computed as:

$$AF = \frac{1 - (1+i)^{-n_{lfe}}}{i} = \sum_{k=1}^{n_{lfe}} \frac{1}{(1+i)^k} \quad (10)$$

### 2.5.1. Future production costs

In the case of baseload electricity, the cost of producing FT waxes was assessed with reference to the year 2030 and 2050 by application of learning curves for the involved technologies and reduction in the baseload power cost. 15 % learning rate was assumed for the DAC unit, as reported in [9]. The cost of alkaline was reduced over time to 415 €/kW and 220 €/kW in 2030 and 2050, as listed by Gorre et al. [76]. Finally, 10 % learning rate was included for the installation of 100 units for the RWGS and FT, in accordance with the statements available from [77] and [78]. The baseload electricity cost corresponded to 75 €/MWh and 60 €/MWh in 2030 and 2050, respectively [69].

## 2.6. Key performance indicators

Key performance indicators (KPIs) were evaluated for each plant solution. The specific plant energy consumption was estimated and expressed both in terms of CO<sub>2</sub> removed from the air and FT waxes production, and expressed as kWh/kg<sub>CO2</sub> and kWh/kg<sub>wax</sub>, respectively:

$$E_{SP_{CO_2}} = \frac{W_{el,in} + Q_{th,in} + \dot{n}_{NG} \cdot LHV_{NG}}{\dot{m}_{CO_2,rem}} \quad (11)$$

$$E_{SP_{wax}} = \frac{W_{el,in} + Q_{th,in} + \dot{n}_{NG} \cdot LHV_{NG}}{\dot{m}_{wax,out}} \quad (12)$$

$$\dot{m}_{CO_2,rem} = \left( \dot{m}_{CO_2,Air,in} \right) - \left( \dot{m}_{CO_2,Air,out} + \dot{m}_{CO_2,Exh,out} \right) \quad (13)$$

where  $\dot{m}_{CO_2,air,in}$ ,  $\dot{m}_{CO_2,air,out}$  and  $\dot{m}_{CO_2,exh,out}$  are the mass flow rate of CO<sub>2</sub> in the streams denoted as “Air in”, “Air out” and “Exhaust” in Fig. 1. The  $W_{el,in}$  and  $Q_{th,in}$  terms represent the net electrical and thermal power required by the plant (kW), respectively.  $\dot{n}_{NG}$  is the molar flow rate of NG (mol/s). LHV is the lower heating value of NG (kJ/mol).

The carbon efficiency ( $\eta_C$ ) was also evaluated. This parameter



accounted for the carbon that is converted into FT liquid products in all the considered configurations.

$$\eta_C = \frac{\left[ \left( \dot{n}_{C_{AIR,in}} + \dot{n}_{C_{NG,in}} \right) - \left( \dot{n}_{C_{AIR,out}} + \dot{n}_{C_{EXH,out}} \right) \right]}{\dot{n}_{C_{AIR,in}} + \dot{n}_{C_{NG,in}}} \quad (14)$$

$\dot{n}_{C_{AIR,in}}$  and  $\dot{n}_{C_{NG,in}}$  are the molar flow rates of carbon entering the system with “Air in” flow rate and the NG stream, respectively.  $\dot{n}_{C_{AIR,out}}$  and  $\dot{n}_{C_{EXH,out}}$  are the molar flow rates of carbon leaving the system with “Air out” flow rate and the exhausts of the burner after the FT, respectively.

The efficiency of carbon dioxide removal from the air ( $\eta_{CO_2}$ ) was evaluated according to the following formula:

$$\eta_{CO_2} = \frac{\left[ \left( \dot{n}_{CO_2,AIR,in} \right) - \left( \dot{n}_{CO_2,AIR,out} + \dot{n}_{CO_2,EXH,out} \right) \right]}{\dot{n}_{CO_2,AIR,in}} \quad (15)$$

$\dot{n}_{CO_2,AIR,in}$  is the molar flow rate of carbon entering the system with “Air in” stream.  $\dot{n}_{CO_2,AIR,out}$  and  $\dot{n}_{CO_2,EXH,out}$  are the molar flow rates of carbon leaving the system, respectively, with the “Air out” flow rate and the exhausts of the burner.

The total plant efficiency ( $\eta_{GI}$ ) was computed as the ratio of the chemical power of the FT liquid products to the plant consumption of electricity (including electrolysis demand), external heat and NG supply (where *LHV* stands for lower heating value) as follows:

$$\eta_{GI} = \frac{\sum \dot{n}_{FT,liq} \cdot LHV_{FT,liq}}{W_{el,in} + Q_{th,in} + \dot{n}_{NG} \cdot LHV_{NG}} \quad (16)$$

In Eqs. (13)–(15), the terms referring to NG stream existed only for configuration C.1.

### 3. Results and discussion

#### 3.1. Mass balances of analysed configurations

The results regarding the mass balances are summarized in Table 7. Concerning the DAC section, all configurations process 250,000 t/h of air, containing 150 t/h of carbon dioxide. This flow joins the gas coming from the absorber, where CO<sub>2</sub> is captured from the exhausts of the combined cycle for C.1, C.2 and C.3. Apart from the baseline configuration C.1, the only source of carbon material is the ambient air stream entering the system. Contrarywise, in configuration C.1 the sources of carbon material are ambient air and NG. The latter injects an additional stream with 14.5 t/h of C into the plant.

Regarding the FT synthesis section, configuration C.1 provides 207.3 t/h of gas fraction and 33.6 t/h of the liquid fraction. The products distribution is presented in Fig. 3. In the same figure, the distribution is broken down into its main contributors: the figure highlights the difference between the gas fraction, separated in the liquid-liquid-gas separator at the outlet of the FT reactor, and the olefins and paraffins in the liquid fraction. The gas fraction is mainly composed of methane, which also accounts for 38.6 %-mol of the total FT products, with a lower concentration of light hydrocarbons up to carbon number C<sub>4</sub>. Considering the liquid fraction, paraffins represent the most relevant compound contributors, with a peak around carbon number C<sub>7-8</sub>, while the olefins can be considered relevant in the carbon number range C<sub>2-12</sub>, with a peak around C<sub>6-7</sub>. This is in good agreement with the research in the field of cobalt-based FT synthesis, where the paraffin fraction is increasingly more influent over the olefins at increasing carbon numbers [79]. It is to note that the total distribution follows the modification of the AFS theory for FT products, as predicted by the kinetic model, and it reaches a linearization of the curve for carbon number higher than C<sub>18-20</sub>. However, compared to the traditional FT distribution, there exists a shift towards heavier hydrocarbons, due to the recirculation of the FT off-gases, providing a local peak at C<sub>7</sub> (a direct comparison of the FT distribution with and without recirculation is available in the

**Table 7**  
Mass balance information.

| Mass flow rate [t/h]                | C.1      | C.2      | C.3      | C.4      | C.5      |
|-------------------------------------|----------|----------|----------|----------|----------|
| Air inlet                           | 250000.0 | 250000.0 | 250000.0 | 250000.0 | 250000.0 |
| Air outlet                          | 248354   | 248379.7 | 248377.9 | 248163.1 | 248163.1 |
| C. Cycle                            | 232.5    | 244.1    | 242.9    | 0.0      | 0.0      |
| Exhausts                            |          |          |          |          |          |
| Absorber Solvent                    | 347.0    | 290.2    | 287.3    | 0.0      | 0.0      |
| Air Contactor Solvent               | 2767.7   | 2764.2   | 2761.7   | 2681.6   | 2681.6   |
| H <sub>2</sub> O Knockout           | 531.0    | 531.0    | 531.0    | 531.0    | 531.0    |
| Natural Gas to C. Cycle             | 12.2     | –        | –        | 0.0      | 0.0      |
| Natural Gas to Calciner             | 110.1    | –        | –        | 0.0      | 0.0      |
| Air to C. Cycle                     | 220.3    | 223.1    | 223.6    | 0.0      | 0.0      |
| Air to Burner                       | 222.4    | 189.1    | 92.2     | 146.9    | 140.4    |
| Burner Exhausts                     | 233.8    | 207.7    | 98.7     | 152.7    | 148.7    |
| Condensed H <sub>2</sub> O          | 130.9    | 75.1     | 84.1     | 74.5     | 94.3     |
| CO <sub>2</sub> to RWGS section     | 123.9    | 159.9    | 149.7    | 93.9     | 142.4    |
| H <sub>2</sub> O electrolysis       | 250.5    | 211.3    | 234.4    | 193.3    | 256.5    |
| O <sub>2</sub> electrolysis         | 133.5    | 113.1    | 124.9    | 103.4    | 137.2    |
| to Calciner                         | 29.5 %   | 33.7 %   | 29.8 %   | –        | 25.5 %   |
| FT Products                         | 240.9    | 99.0     | 117.3    | 114.5    | 163.2    |
| Gas fraction to burner              | 11.4     | 18.4     | 6.5      | 5.8      | 8.3      |
| Gas fraction recirculated           | 195.9    | 67.4     | 92.3     | 82.1     | 128.6    |
| Liquid/Wax fraction                 |          |          |          |          |          |
| (C <sub>5</sub> -C <sub>11</sub> )  | 11.98    | 5.01     | 6.98     | 9.94     | 9.75     |
| (C <sub>11</sub> -C <sub>20</sub> ) | 12.9     | 4.7      | 6.63     | 9.72     | 9.66     |
| (C <sub>20</sub> +)                 | 8.7      | 3.5      | 4.8      | 6.94     | 6.83     |
| Gas fraction recirculation          |          |          |          |          |          |
| to RWGS                             | 95.0 %   | –        | 37.1 %   | 95.00 %  | 77.30 %  |
| to C. Cycle                         | –        | 24.9 %   | 19.9 %   | –        | –        |
| to Calciner                         | –        | 54.7 %   | 38.0 %   | –        | 22.70 %  |

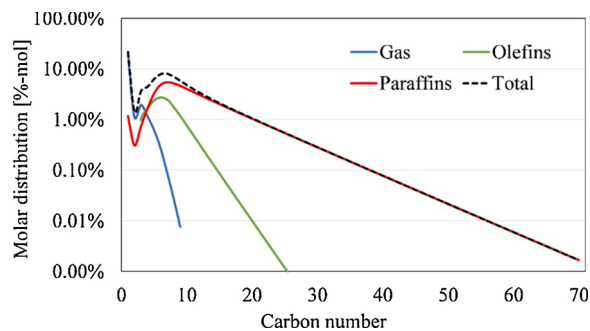

**Fig. 3.** FT products distribution of C.1: global FT distribution (black dashed line) and break-down of the products’ components.

Supporting Material).

Depending on the recirculation solution applied (to the RWGS and/or the DAC) the throughput of synthetic material collected at the outlet of the FT reactor changes, and so does the FT distribution. Such a trend can be noticed from the results listed in Table 7 and from the FT distributions provided in Fig. 4. With respect to the production of FT material, configurations C.2 to C.5 all present a slight reduction in the total amount of FT hydrocarbons with respect to the baseline C.1: the difference is particularly significant for products with a carbon number higher than C<sub>4</sub> (C<sub>5</sub> for configuration C.2). Configuration C.1 seems to be the most suitable solution when targeting a high amount of FT liquid products. This behavior could be linked to different factors. Firstly, C.1 introduces in the system more carbon with the NG flow, determining a higher amount of carbon material looping in the plant that reacts to

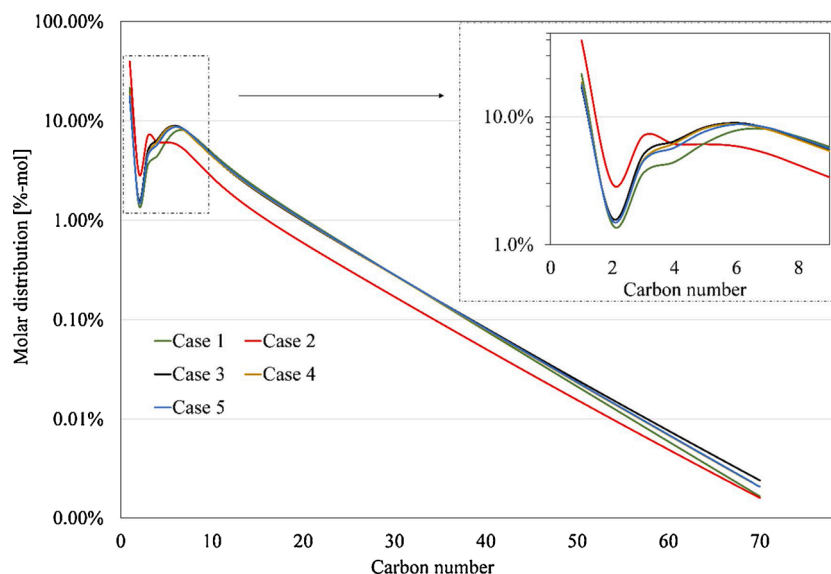

Fig. 4. FT products distribution: scenarios comparison on molar share.

synthetic FT compounds. Secondly, C.2 and C.3 deliver a part of the carbon dioxide entering the system back to the air contactor, whose capture efficiency of 75 % determines a small loss of carbon material towards the environment [28]. This could also explain the slightly lower synthesis of FT compounds in configuration C.3 with respect to C.2, although both designs recycle 95 % of the off-gas. Finally, configurations C.4 and C.5 present very similar production results in terms of liquid fraction. In case C.4, carbon dioxide is looped only within the RWGS reactor, determining a conversion to CO by reaction with unconverted hydrogen. Contrarywise, in C.5 part of the FT off-gas are sent to the calciner for the oxy-combustion process, determining a rise in the CO<sub>2</sub> content sent to the RWGS and the latter higher demand for hydrogen and a higher throughput of light gases.

In terms of products distribution, configuration C.2 should be discarded, as the shift towards heavy hydrocarbons is not as remarkable as in the other cases. C.1 can be a profitable solution to shift towards high molecular weight products, but it presents a distribution peak at C<sub>7</sub> (the highest carbon number peak among the configurations, as depicted in the zoomed section of Fig. 4) which turns in a tail at carbon number higher than C<sub>40-45</sub> going towards C.2. Lastly, configurations C.3, C.4, and C.5 suggest being the most suitable solution when targeting heavy hydrocarbons due to the higher concentration of products with a carbon number higher than C<sub>20+</sub>. This result is interesting from an economic standpoint, since recent market analyses report demand for heavy waxes in the paraffinic form [80].

As a matter of fact, looping the FT off-gas to the DAC and the RWGS units allow reforming of light hydrocarbons. Moreover, dragging inert nitrogen in the recirculated flows could influence the partial pressures of reactants in both the RWGS and the FT reactors and their efficiencies, shifting the selectivity towards heavier hydrocarbons [4,81]. Remarkably, no solid carbon is deposited onto the RWGS reactor in any of the cases, thus no addition of external oxygen carrier to this reactor is required (See supporting material for C-deposition check).

### 3.2. Energy balance

The information about energy balances is provided in Table 8. Considering the electric power, the electrolyzer is the most energy-intensive component, accounting for more than 85 % of the absorbed power regardless of the system configurations. Remarkably, C.4 is the configuration with the lowest electrolyzer consumption, possibly due to a more virtuous hydrogen management provided by the FT off-gas

Table 8

Energy balance information for each configuration.

| [MW]                      | C.1     | C.2     | C.3     | C.4     | C.5     |
|---------------------------|---------|---------|---------|---------|---------|
| <b>Electric power</b>     |         |         |         |         |         |
| Auxiliaries               | 0.92    | 0.69    | 0.72    | 0.63    | 0.83    |
| CC Compression            | 22.06   | 22.35   | 22.40   | 0.00    | 0.00    |
| FT compression            | 101.05  | 32.26   | 43.81   | 59.09   | 66.25   |
| Electrolysis              | 838.09  | 707.16  | 784.31  | 646.74  | 858.14  |
| CC Turbine                | -30.01  | -30.00  | -30.03  | 0.00    | 0.00    |
| Slake Steam-Turbine       | -22.39  | -24.92  | -24.95  | -21.88  | -25.06  |
| <b>Chemical content</b>   |         |         |         |         |         |
| NG/FT off-gas CC          | 140.54  | 0       | 0.00    | 0.00    | 0.00    |
| NG/FT off-gas<br>Calciner | 127.55  | 0       | 0.00    | 0.00    | 0.00    |
| FT liquid products        | -419.78 | -166.49 | -235.84 | -337.73 | -331.21 |
| <b>Thermal power</b>      |         |         |         |         |         |
| Heaters                   | 343.03  | 293.80  | 301.00  | 334.51  | 324.75  |
| Coolers                   | -507.80 | -339.40 | -339.60 | -339.22 | -386.63 |
| RWGS reactor              | 182.12  | 41.14   | 69.53   | 123.67  | 117.86  |
| FT reactor                | -210.36 | -80.94  | -111.30 | -154.80 | -159.81 |
| Pellet reactor            | -13.14  | -6.77   | -6.93   | -5.47   | -5.47   |
| Slaker reactor            | -46.31  | -41.89  | -41.89  | -46.31  | -41.89  |
| TG Comb                   | -81.27  | -1.97   | -11.14  | 0.00    | 0.00    |
| Calciner                  | 0.00    | 0.00    | 0.00    | 128.47  | 0.00    |

recirculation to the RWGS only. Contrarywise, when recycling the FT off-gas to the DAC unit, hydrogen exists the system in the form of water, due to reaction in the calciner reactor. However, configuration C.4 requires 128 MW<sub>el</sub> to sustain the reactions evolving in the electrified calciner.

Regarding the chemical power of NG, this directly depends on the mass flow rate entering the combined cycle and the calciner. 64 % of the power content of the NG is fed to the calciner in C.1. Moreover, given the higher amount of FT liquid products obtained in C.1, this configuration also provides the highest energy content in the synthetic hydrocarbons. However, such a thermal power is completely avoided for all the other configuration, where NG is excluded.

With respect to the thermal power of the system, the heaters absorb more than 60 % of the required thermal power, with a peak of 86.2 % required for the heaters in configuration C.2 and 64.3 % as the lowest condition in design C.1. Similarly, coolers in design C.1 require 58.8 % of the cooling power, whereas in C.2 account for 70.9 %, C.3 65.3 %, C.4 61.2 %, C.5 64.1 %. Concerning the main components of the plant, the washer and the absorber column disperse thermal power to the

environment, while calciner operates at adiabatic conditions, besides under configuration C.4. However, heat fluxes exchanged by the flows at inlets and outlets of these components are considered in the heaters and coolers. The RWGS reactor is the most critical component: it requires a high amount of thermal power for isothermal conditions, with C.1 requiring 182 MW<sub>th</sub> for operations as the highest value, and C.2 requiring 41 MW<sub>th</sub> as the lowest value (Fig. 5).

### 3.3. Thermal integration

Thermal integration among cold and hot streams through a network of recovery heat exchangers ( $\Delta T_{\min} = 15\text{ }^{\circ}\text{C}$ ) was investigated applying pinch analysis methodology to minimize the heat supply from the environment. Fig. 6 provides the results on the pinch analysis applied to the considered system configurations. Both hot and cold composite curves are shown. Table 9 presents the thermal energy required by each case before and after optimal energy integration. It is worth noting how the integration process sensibly reduces the heat required by the plant.

Even in this case, it is possible to address the RWGS reactor as the most critical thermal sink, creating a plateau at 800 °C. In the case of surplus energy demand, electric heaters could supply the required amount. Moreover, in all the cases studied, three plateaux can be identified in the hot composite curves at 300 °C, 230 °C and 99 °C corresponding to the slaker reactor, the FT reactor and the phase change of the steam leaving the slaker steam turbine, respectively. The first two heat fluxes can potentially be employed to heat low-temperature streams (e.g., the steam entering the slaker), and to preheat the gas mixture entering the RWGS reactor

### 3.4. Key performance indicators

KPIs were evaluated considering each case under the optimal energy integration presented in section 3.3: these are presented in Table 10. Configuration C.1 has the highest energy consumption per mass of CO<sub>2</sub> removed from the air ( $E_{\text{SPCO}_2} = 13.9\text{ kW h/kg}_{\text{CO}_2}$ ) due to the feeding of

extra natural gas. However, it reaches the midd value of 154.7 kW h/kg<sub>wax</sub> thanks to the highest production of FT material. It also presents a plant efficiency  $\eta_{\text{GI}}$  of 31.2 %, a CO<sub>2</sub> removal efficiency  $\eta_{\text{CO}_2}$  of 64.4 % and a carbon efficiency  $\eta_{\text{C}}$  of 73.8 %. The latter is the highest among the configurations, due to the presence of additional carbon material fed with natural gas.

On the contrary, it is possible to note how solution C.2 provides the highest energy consumption when referred to the amount of FT waxes produced by the system (210.5 kW h/kg<sub>wax</sub>), as well as the lowest system efficiency and carbon conversion (58.1 % and 22.6 %). Hence, once again, configuration C.2 shall be discarded. It is to note that the carbon conversion and the CO<sub>2</sub> conversion efficiencies of C.2-C.5 are the same, as no additional carbon is fed with the avoidance of fossil natural gas.

Moreover, C.3  $\eta_{\text{GI}}$  and  $\eta_{\text{C}}$  are only a few percentage points lower than the corresponding values of C.1, and it is important to remark that configuration C.3 has the highest value of carbon dioxide removal from the air (almost  $\eta_{\text{CO}_2} = 70\%$ ). This means that substituting the flow of NG with FT off-gas considerably increases the usage of carbon material captured from the air, and it is beneficial from an environmental point of view, when presenting high FT off-gas recirculation rates. From this point of view, even C.4 and C.5 have better performance than C.1, both as global plant efficiency and conversion of carbon dioxide into FT material. Moreover, configuration C.4 provides the highest  $\eta_{\text{GI}}$  at 36.5 %, connected to the much lower electric demand of the electrolyser.

Thus, from a production perspective, configuration design C.1 can be preferential. Nonetheless, configuration C.3 results in a most suitable solution to extract CO<sub>2</sub> from the air, with C.4 and C.5 outperforming C.1 also in terms of plant efficiency.

## 4. Economic evaluation

The economic analysis provides the systems installation and operations costs, as well as economic indicators identified in the FT wax production cost and the CO<sub>2</sub> removal cost.

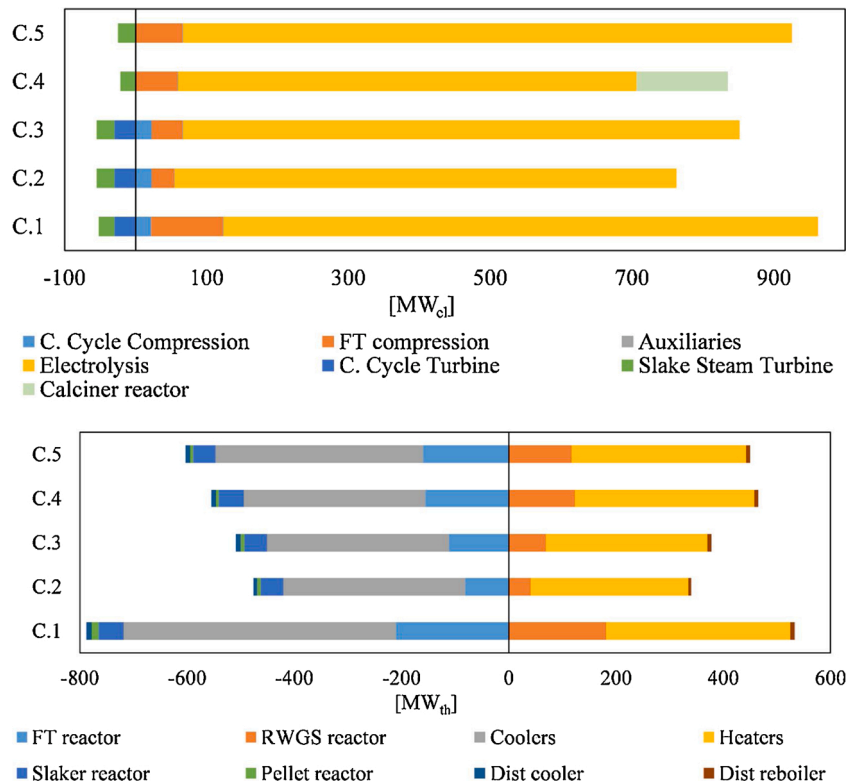

Fig. 5. Inlet and outlet power for the main plant components: electric (top) and thermal powers (bottom) are shown.

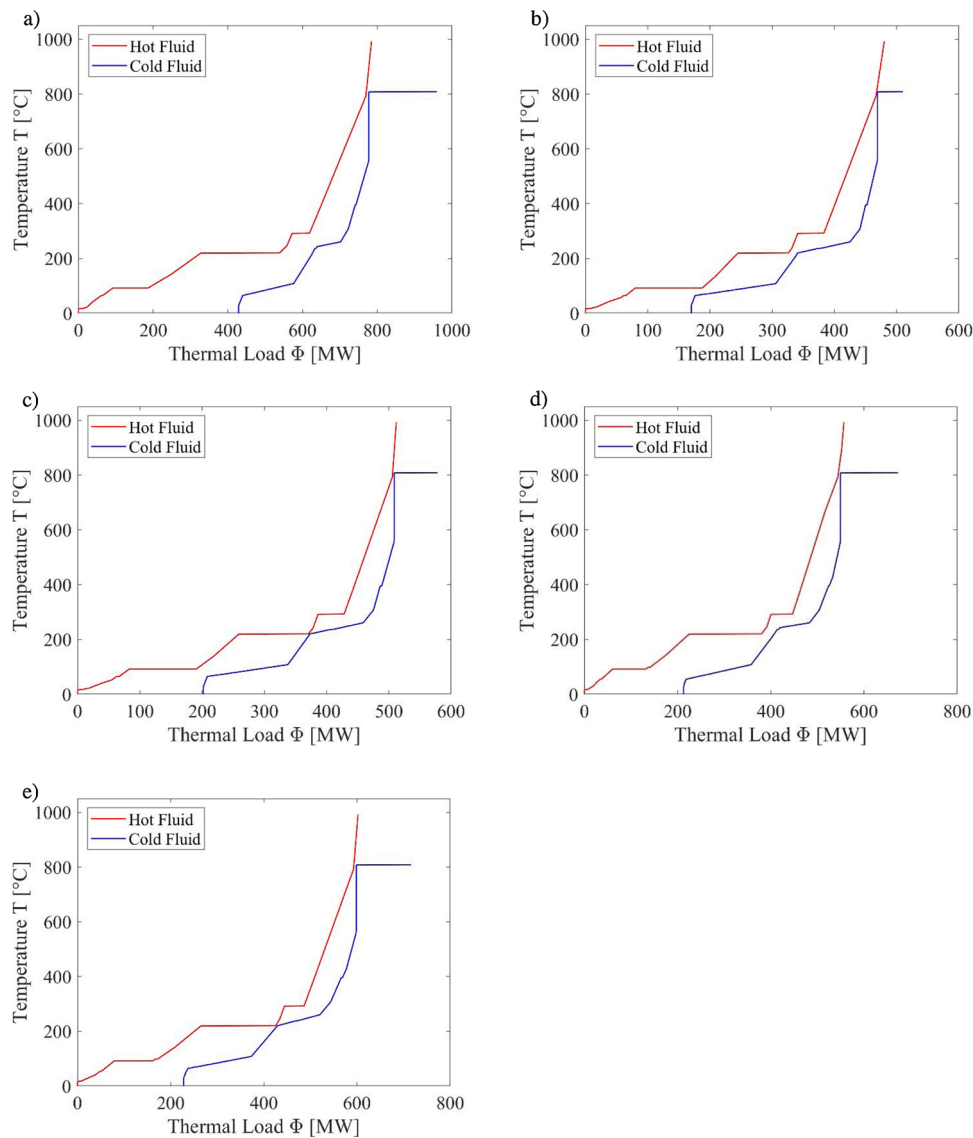

Fig. 6. Hot and cold composite curves for each configuration derived by the Pinch Analysis: a) C.1; b) C.2; c) C.3; d) C.4; e) C.5.

**Table 9**  
Energy integration effect on the plants heat demand.

| [MW <sub>th</sub> ]         | C.1   | C.2   | C.3   | C.4   | C.5   |
|-----------------------------|-------|-------|-------|-------|-------|
| Heat Demand W/o Integration | 531.0 | 342.8 | 379.0 | 592.4 | 487.9 |
| Heat Demand W/ Integration  | 168.2 | 28.8  | 63.7  | 111.8 | 109.1 |

**Table 10**  
Key performance indicators results.

| KPI   | C.1     | C.2    | C.3    | C.4    | C.5    |
|---|---------|--------|--------|--------|--------|
| ES <sub>PCO2</sub> [kWh/kg <sub>CO2</sub> ] | 13.9    | 8.5    | 8.4    | 9.2    | 10.1   |
| ES <sub>PWax</sub> [kWh/kg <sub>wax</sub> ] | 154.7   | 210.5  | 179.2  | 133.4  | 147.8  |
| η <sub>C</sub>                              | 73.78 % | 58.1 % | 68.3 % | 67.2 % | 66.4 % |
| η <sub>CO2</sub>                            | 64.4 %  | 58.1 % | 68.3 % | 67.2 % | 66.4 % |
| η <sub>GI</sub>                             | 31.2 %  | 22.6 % | 27.2 % | 36.5 % | 32.8 % |

#### 4.1. Capital cost

Following the methodology described in Section 2.5, an overall CAPEX of 1.87 G€ (billions of €) was obtained for the baseline scenario C.1. From Fig. 7 it is possible to note a reduction of the CAPEX value of

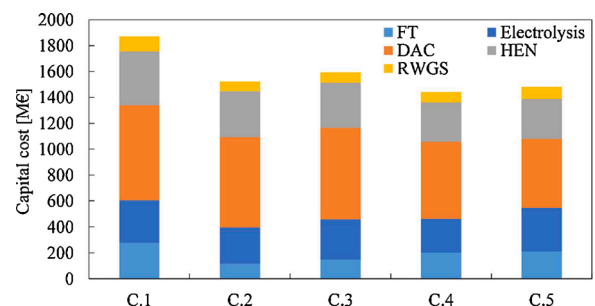

Fig. 7. Distribution of the CAPEX in the different sections of the CCU plant.

14–23 % in scenarios C.2 to C.5. Specifically, this is mainly related to a lower cost of the RWGS and the FT reactors units, where a higher amount of material processed in C.1 determine a rise in their capital costs. Additionally, for configurations C.4 and C.5, the reduced value is connected to the lower installation costs applied for the DAC section, either electrified or without the combined cycle section [9], and the reduced size of the electrolyser of C.4. In all the studied configurations, the DAC unit accounts between 28.6 % (in C.5) to 39.2 % (in C.2) of the



total CAPEX, the electrolyser between 14%–18%, while the FT synthesis unit and distillation unit account for 6–15 % of the CAPEX. A detailed cost breakdown is provided in Table S5 of the Supporting Material.

#### 4.2. Operating costs

With a comprehensive estimation of the operating costs starting from the mass and energy balances of the plant, the breakdown of the OPEX is provided in Fig. 8, with a presentation of both non-electric and electric OPEX. In all the studied configurations, the sum of the non-electric OPEX ranges between 89 and 129 M€/y, corresponding to C.4 and C.1, respectively. The non-electric OPEX value is counterbalanced by the revenues from the sale of the process by-products: oxygen, naphtha, and middle FT distillate. Specifically for configurations C.1, C.4, and C.5, the revenues exceed the non-electric OPEX (149 vs. 129 M€/y, 135 vs. 89 M€/y, and 134 vs. 100 M€/y, respectively), with a beneficial effect on the plant economics. In configuration C.3, the same value of revenues and non-electric OPEX is reached (103.2 and 104 M€/y, respectively), while C.2 has non-beneficial costs, with the non-electric OPEX being at 102 M€/y and revenues at only 81 M€/y.

Moreover, the cost of running the electrically fed equipment of the plants was studied (i.e., electric OPEX). The biggest contribution to the electric operating costs is represented by the electrolysis section, in compliance with the outcome of the energy balance (Table 8). Depending on the plant configuration, this cost represents between 70–78 % of the electric OPEX in the scenario fed with hydropower-generated electricity, and up to 79–90 % in the scenario employing CSP electricity. Lastly, the overall highest electric OPEX was found in the process design C.1. As expected, based on the costs selected, the hydropower is the most effective solution, reaching the lowest values of electric-related OPEX. However, as mentioned in the Methodology section, the cost of electricity based on baseload values from mix RES provides a more conservative value [69].

#### 4.3. Production costs

Fig. 9 depicts the costs of FT waxes production evaluated according to eq. (8). Configuration C.1 and C.4 reach similar wax production costs, with this C.4 being the most promising configuration. In this case, the wax production cost ranges between 5.05 €/kg<sub>wax</sub> and 25.0 €/kg<sub>wax</sub> at 0% interest rate, 6.3 €/kg<sub>wax</sub> and 26.3 €/kg<sub>wax</sub> at 7.5 %, and 7.4 €/kg<sub>wax</sub> and 27.4 €/kg<sub>wax</sub> at 12.5 %, where the lower costs result from hydropower electricity feed and the higher costs from mixed RES baseload electricity feed. In the case of C.1, its low production cost can be related to the high amount of Fischer-Tropsch material that is produced. On the contrary, for C.4, such a cost is related to the low installation cost and operating costs. Moreover, even from a cost of wax production point of view, configuration C.2 shall be discarded as preferential one, given the

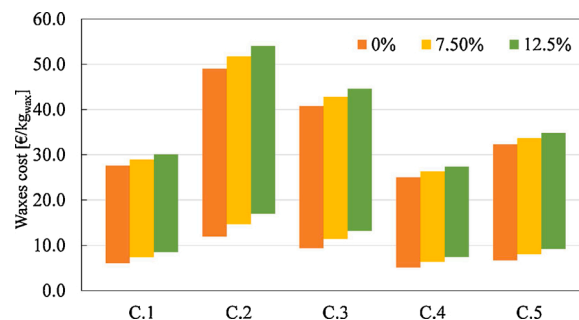

Fig. 9. Ranges of the cost of FT waxes production under different interest rates. The minimum price level corresponds to hydropower electricity source, the maximum to baseload one.

high installation costs and low throughput of FT compounds. Finally, configuration C.3 and C.5 are the intermediate solutions, with C.5 reaching a lower production costs given the avoidance of the combined cycle unit. For this configuration, the cost range corresponds to 6.7–32.3 €/kg<sub>wax</sub> at 0% interest rate, 8.0–33.7 €/kg<sub>wax</sub> at 7.5 %, and 9.2–34.8 €/kg<sub>wax</sub> at 12.5 %.

From an FT production cost point of view, the present system results in a higher marginal value compared to market fossil-derived paraffin wax cost that is about 2.50 €/kg<sub>wax</sub>, even when considering low-priced electricity scenarios [82,83]. This can be related to the electrolyser and DAC units cost, which may be economically unfeasible without carbon credits or incentives. For instance, Karki et al. [84] determined a cost of 2.40 €/kg<sub>wax</sub> (carbon number C<sub>18+</sub>) when exploiting the CO<sub>2</sub> from a concentrated point source, making the source of CO<sub>2</sub> economically relevant. Hence, external incentives would be required for the feasible production of synthetic material with this type of route. As stated by Herz et al. [83], a CO<sub>2</sub> compensation of 300 €/t<sub>CO2</sub> might allow the market entry of alternative-to-oil routes for hydrocarbons production. Considering the upper-cost reference of 2.50 €/kg<sub>wax</sub>, the present system would reach a feasible solution under configuration C.1, C.4, and C.5 at interest rates of 0% (compensation of 204 €/t<sub>CO2</sub>, 175 €/t<sub>CO2</sub>, and 287 €/t<sub>CO2</sub>, respectively) and configuration C.1 and C.4 at interest rate of 7.5 % (compensation of 282 €/t<sub>CO2</sub> and 264 €/t<sub>CO2</sub>) in scenario of electricity supply from hydropower source. If onshore wind electricity was to be employed, the feasibility would be granted only at 0% interest rate for configurations C.1 and C.4, with a carbon dioxide compensation of 282 €/t<sub>CO2</sub> and 264 €/t<sub>CO2</sub>, respectively. Contrarywise, for C.4 (the most promising configuration) if baseload electricity was utilized, a credit 1549 €/t<sub>CO2</sub> would be needed.

#### 4.4. Future production cost

Utilizing baseload electricity of mixed source is currently unfeasible,

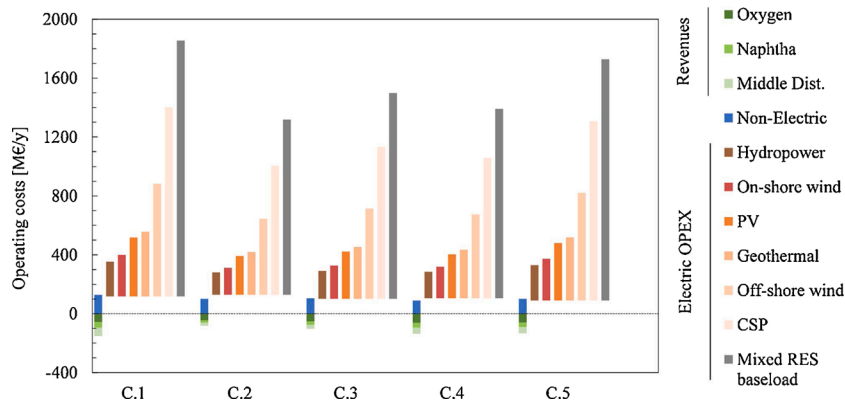

Fig. 8. Revenues and operating costs considered in the definition of the free cash flow.

from both a waxes production cost point of view and a possible compensation related to the amount of carbon dioxide removed from the air. Hence, in accordance with the forecast analyses proposed by Fasihi et al. [9,69] and Gorre et al. [76], the costs of FT waxes production in the year 2030 and 2050 are provided in Fig. 10. Predictably, both the application of experience rates on the cost of components and a reduction of the baseload electricity cost provide a sensible reduction in the year 2030 and 2050 compared to the baseline analysis. Predictably, configuration C.4 remains the most profitable solution: at year 2030 the wax production cost ranges from 7.9 €/t<sub>CO<sub>2</sub></sub> to 9.0 €/t<sub>CO<sub>2</sub></sub>, and 5.9 and 6.7 €/t<sub>CO<sub>2</sub></sub> at the year 2050 (Table 11). Such a cost could be further reduced if the actual learning rates of the DAC and electrolyser technologies would increase up to 20%.

## 5. Conclusions

In the baseline configuration, 124 t/h of CO<sub>2</sub> are utilized to synthesize 8.7 t/h of Fischer-Tropsch waxes, with a plant efficiency ( $\eta_{GI}$ ) of 33.2 %. In configurations C.2, C.3, C.4 and C.5, the net FT waxes production corresponds to 3.5 t/h, 4.8 t/h, 6.9 t/h and 6.8 t/h, respectively. Consequently, the plant efficiency changes to 22.6 %, 27.2 %, 36.5 %, and 32.8 %, respectively, due to the variation in both the FT production and energy consumption. Lastly,  $\eta_{CO_2}$  varies to 58.1 %, 68.3 %, 67.2 %, and 66.4 % in C.2, C.3, C.4, and C.5 configurations, respectively, starting from the baseline value of 31.2 % (configuration C.1). Hence, considering only the production of FT material, configuration C.1 is the most effective solution. However, this configuration comes with the drawback of utilizing natural gas, a fossil material that has to be avoided. Hence, this configuration should be avoided. From an environmental point of view, configuration C.3 is the most effective in removing carbon dioxide from the air, only one percentage point higher than in configuration C.4. Finally, configuration C.4 is the best one when considering the overall production costs of FT waxes. If utilizing hydropower electricity source, this cost corresponds to 5.05 €/kg<sub>wax</sub>. Carbon credits can provide a feasible market entry of this CO<sub>2</sub>-to-FT wax route, that helps offsetting the high capital cost of the DAC unit. At 7.5 % interest rate for the scenario C.4, the FT wax breakeven can be reached at 264 €/t<sub>CO<sub>2</sub></sub> with electricity from hydropower source. At 0% interest rate, the same result is reached with 175 €/kg<sub>CO<sub>2</sub></sub> as credits. Moreover, if utilizing baseload electricity, profitable applications of this process route shall be expected from the year 2030, when a reduction of the components cost (DAC, electrolyser, system reactors) and of the baseload electricity cost from mixed RES can be expected.

## Funding

This work received funding from the Politecnico di Torino and the European Union's *Horizon 2020 research and innovation programme* under grant agreement No. 768543 ("ICO2CHEM").

## CRedit authorship contribution statement

**Marco Marchese:** Conceptualization, Methodology, Formal analysis, Investigation, Software, Data curation, Writing - original draft, Visualization. **Giulio Buffo:** Conceptualization, Investigation, Data curation, Writing - review & editing. **Massimo Santarelli:** Supervision, Writing - review & editing. **Andrea Lanzini:** Supervision, Project administration, Writing - review & editing.

## Declaration of Competing Interest

N.A.

## Appendix A. Supplementary data

Supplementary data associated with this article can be found, in the

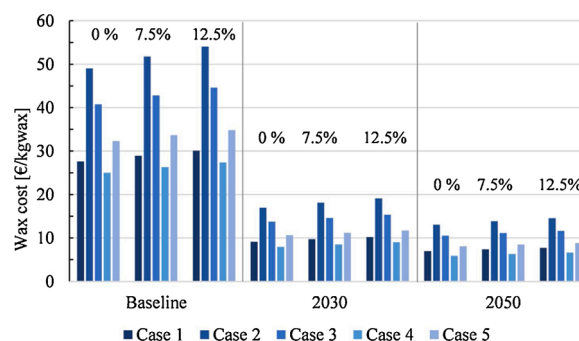

Fig. 10. Cost of wax production utilizing baseload electricity in the year 2030 and 2050.

Table 11

Evolution of CAPEX and OPEX at the year 2030 and 2050. <sup>a</sup>Accounted at the baseload electricity price.

| CAPEX             | Unit | C.1    | C.2    | C.3    | C.4    | C.5    |
|-------------------|------|--------|--------|--------|--------|--------|
| Baseline          | M€   | 1871   | 1524   | 1595   | 1440   | 1483   |
| 2030              | M€   | 796    | 653    | 667    | 655    | 639    |
| 2050              | M€   | 575    | 449    | 463    | 458    | 454    |
| OPEX <sup>a</sup> |      |        |        |        |        |        |
| Baseline          | M€/y | 1996.3 | 1393.6 | 1604.9 | 1465.6 | 1839.8 |
| 2030              | M€/y | 754.9  | 529.5  | 604.5  | 550.7  | 688.8  |
| 2050              | M€/y | 612.7  | 429.0  | 489.0  | 444.4  | 557.0  |
| Revenues          | M€/y | 149.9  | 81.0   | 103.2  | 135.2  | 133.7  |

online version, at <https://doi.org/10.1016/j.jcou.2021.101487>.

## References

- [1] Global Warming of 1.5 °C - An IPCC Special Report on the Impacts of Global Warming of 1.5 °C Above pre-Industrial Levels and Related Global Greenhouse Gas Emission Pathways, in the Context of Strengthening the Global Response to the Threat of Climate Change, IPCC, Geneva, Switzerland, 2018.
- [2] European Commission, A Clean Planet for All - A European Long-Term Strategic Vision for a Prosperous, Modern, Competitive and Climate Neutral Economy, Eur. Comm., 2018, p. 114. [https://ec.europa.eu/clima/sites/clima/files/docs/page\\_s/com\\_2018\\_733\\_en.pdf?utm\\_campaign=AktuellHällbarhetDirekten\\_181129\\_Username&utm\\_medium=email&utm\\_source=Eloqua&elqTrackId](https://ec.europa.eu/clima/sites/clima/files/docs/page_s/com_2018_733_en.pdf?utm_campaign=AktuellHällbarhetDirekten_181129_Username&utm_medium=email&utm_source=Eloqua&elqTrackId).
- [3] E. Rozzi, F.D. Minuto, A. Lanzini, P. Leone, Green synthetic fuels: renewable routes for the conversion of non-fossil feedstocks into gaseous fuels and their end uses, *Energies* 13 (2020), <https://doi.org/10.3390/en13020420>.
- [4] G. Herz, E. Reichelt, M. Jahn, Techno-economic analysis of a co-electrolysis-based synthesis process for the production of hydrocarbons, *Appl. Energy* 215 (2018) 309–320, <https://doi.org/10.1016/j.apenergy.2018.02.007>.
- [5] G. Buffo, D. Ferrero, M. Santarelli, A. Lanzini, Energy and environmental analysis of a flexible power-to-X plant based on reversible solid oxide cells (rSOCs) for an urban district, *J. Energy Storage* 29 (2020) 101314, <https://doi.org/10.1016/j.est.2020.101314>.
- [6] J. Lehtonen, V. Järnefelt, S. Alakurtti, A. Arasto, I. Hannula, A. Harlin, T. Koljonen, R. Lantto, M. Lienemann, K. Onarheim, J.-P. Pitkänen, M. Tähtinen, The carbon reuse economy: transforming CO<sub>2</sub> from a pollutant into a resource, *VTT Tech. Res. Cent. Finl.* (2019), <https://doi.org/10.32040/2019.978-951-38-8709-4>.
- [7] D.W. Keith, Why capture CO<sub>2</sub> from the atmosphere? *Science* (80-) 325 (2009) 1654–1655, <https://doi.org/10.1126/science.1175680>.
- [8] F.D. Meylan, V. Moreau, S. Erkman, CO<sub>2</sub> Utilization in the Perspective of Industrial Ecology, an Overview, 2015, <https://doi.org/10.1016/j.jcou.2015.05.003>.
- [9] M. Fasihi, O. Efimova, C. Breyer, Techno-economic assessment of CO<sub>2</sub> direct air capture plants, *J. Clean. Prod.* 224 (2019) 957–980, <https://doi.org/10.1016/j.jclepro.2019.03.086>.
- [10] E.S. Sanz-Pérez, C.R. Murdock, S.A. Didas, C.W. Jones, Direct capture of CO<sub>2</sub> from ambient air, *Chem. Rev.* 116 (2016) 11840–11876, <https://doi.org/10.1021/acs.chemrev.6b00173>.
- [11] F. Zeman, Energy and material balance of CO<sub>2</sub> capture from ambient air, *Environ. Sci. Technol.* 41 (2007) 7558–7563, <https://doi.org/10.1021/es070874m>.
- [12] V. Nikulshina, C. Gebald, A. Steinfeld, CO<sub>2</sub> capture from atmospheric air via consecutive CaO-carbonation and CaCO<sub>3</sub>-calcination cycles in a fluidized-bed solar reactor, *Chem. Eng. J.* (2009), <https://doi.org/10.1016/j.cej.2008.06.005>.
- [13] R.M. Cuéllar-Franca, A. Azapagic, Carbon capture, storage and utilisation technologies: a critical analysis and comparison of their life cycle environmental impacts, *J. CO<sub>2</sub> Util.* 9 (2015) 82–102, <https://doi.org/10.1016/j.jcou.2014.12.001>.

- [14] S.M. Jarvis, S. Samsatli, Technologies and infrastructures underpinning future CO<sub>2</sub> value chains: a comprehensive review and comparative analysis, *Renew. Sustain. Energy Rev.* 85 (2018) 46–68, <https://doi.org/10.1016/j.rser.2018.01.007>.
- [15] N. Moazzami, M.L. Wyszynski, K. Rahbar, A. Tsolakis, H. Mahmoudi, A comprehensive study of kinetics mechanism of Fischer-Tropsch synthesis over cobalt-based catalyst, *Chem. Eng. Sci.* 171 (2017) 32–60, <https://doi.org/10.1016/j.ces.2017.05.022>.
- [16] E. Iglesia, Design, synthesis, and use of cobalt-based Fischer-Tropsch synthesis catalysts, *Appl. Catal. A, Gen.* 161 (1997) 59–78.
- [17] A. Rafiee, M. Panahi, K.R. Khalilpour, CO<sub>2</sub> utilization through integration of post-combustion carbon capture process with Fischer-Tropsch gas-to-liquid (GTL) processes, *J. CO<sub>2</sub> Util.* 18 (2017) 98–106, <https://doi.org/10.1016/j.jcou.2017.01.016>.
- [18] S.S. Ail, S. Dasappa, Investigations into enhanced wax production with combustion synthesized Fischer-Tropsch catalysts, *Energy Convers. Manag.* 116 (2016) 80–90, <https://doi.org/10.1016/j.enconman.2016.02.075>.
- [19] F. Vidal Vázquez, J. Koponen, V. Ruuskanen, C. Bajamundi, A. Kosonen, P. Simell, J. Ahola, C. Frilund, J. Elfving, M. Reinikainen, N. Heikkinen, J. Kauppinen, P. Piermartini, Power-to-X technology using renewable electricity and carbon dioxide from ambient air: SOLETAIR proof-of-concept and improved process concept, *J. CO<sub>2</sub> Util.* 28 (2018) 235–246, <https://doi.org/10.1016/j.jcou.2018.09.026>.
- [20] Kopernikus projekte, 2019. <https://www.kopernikus-projekte.de/>.
- [21] P. Viebahn, A. Scholz, O. Zelt, The potential role of direct air capture in the German energy research program—results of a multi-dimensional analysis, *Energies* 12 (2019) 1–27, <https://doi.org/10.3390/en12183443>.
- [22] C. van der Giesen, R. Kleijn, G.J. Kramer, Energy and climate impacts of producing synthetic hydrocarbon fuels from CO<sub>2</sub>, *Environ. Sci. Technol.* 48 (2014) 7111–7121, <https://doi.org/10.1021/es500191g>.
- [23] M. Fasihi, D. Bogdanov, C. Breyer, Economics of Global Gas-To-Liquids (GtL) Fuels Trading Based on Hybrid Pv-Wind Power Plants; Economics of Global Gas-To-Liquids (GtL) Fuels Trading Based on Hybrid Pv-Wind Power Plants, 2015.
- [24] M. Fasihi, D. Bogdanov, C. Breyer, Techno-economic assessment of power-to-liquids (PTL) fuels production and global trading based on hybrid PV-wind power plants, *Energy Procedia* (2016) 243–268, <https://doi.org/10.1016/j.egypro.2016.10.115>. Elsevier Ltd.
- [25] M. Fasihi, D. Bogdanov, C. Breyer, Long-term hydrocarbon trade options for the Maghreb region and Europe-renewable energy based synthetic fuels for a net zero emissions world, *Sustain* 9 (2017), <https://doi.org/10.3390/su9020306>.
- [26] C.M. Liu, N.K. Sandhu, S.T. McCoy, J.A. Bergerson, A Life Cycle Assessment of Greenhouse Gas Emissions from Direct Air Capture and Fischer-Tropsch Fuel Production, 2020, <https://doi.org/10.1039/c9se00479c>.
- [27] M. Mansouri, H. Atashi, A.A. Mirzaei, Hydrogenation of CO on cobalt catalyst in Fischer-Tropsch synthesis, *J. Thermodyn. Catal.* 03 (2012), <https://doi.org/10.4172/2157-7544.1000113>.
- [28] D.W. Keith, G. Holmes, D.St. Angelo, K. Heidel, A process for capturing CO<sub>2</sub> from the atmosphere, *Joule* 2 (2018) 1573–1594, <https://doi.org/10.1016/j.joule.2018.05.006>.
- [29] S. Jürgens, P. Obwald, M. Selinsek, P. Piermartini, J. Schwab, P. Pfeifer, U. Bauder, S. Ruoff, B. Rauch, M. Köhler, Assessment of combustion properties of non-hydroprocessed Fischer-Tropsch fuels for aviation, *Fuel Process. Technol.* 193 (2019) 232–243, <https://doi.org/10.1016/j.fuproc.2019.05.015>.
- [30] K.S. Lackner, Capture of carbon dioxide from ambient air, *Eur. Phys. J. Spec. Top.* 176 (2009) 93–106, <https://doi.org/10.1140/epjst/e2009-01150-3>.
- [31] C. Falter, V. Batteiger, A. Sizmann, Climate Impact and Economic Feasibility of Solar Thermochemical Jet Fuel Production, 2015, <https://doi.org/10.1021/acs.est.5b03515>.
- [32] L.E. Hombach, L. Doré, K. Heidgen, H. Maas, T.J. Wallington, G. Walther, Economic and environmental assessment of current (2015) and future (2030) use of E-fuels in light-duty vehicles in Germany, *J. Clean. Prod.* 207 (2019) 153–162, <https://doi.org/10.1016/j.jclepro.2018.09.261>.
- [33] A. García, J. Monsalve-Serrano, D. Villalta, R.L. Sari, V. Gordillo Zavaleta, P. Gaillard, Potential of e-Fischer Tropsch Diesel and Oxymethyl-Ether (OMEx) as Fuels for the Dual-Mode Dual-Fuel Concept, 2019, <https://doi.org/10.1016/j.apenergy.2019.113622>.
- [34] P. Schmidt, V. Batteiger, A. Roth, W. Weindorf, T. Raksha, Power-to-liquids as renewable fuel option for aviation: a review, *Chemie-Ingenieur-Technik* 90 (2018) 127–140, <https://doi.org/10.1002/cite.201700129>.
- [35] P. Schmidt, W. Weindorf, Power-to-Liquids: Potentials and Perspectives for the Future Supply of Renewable Aviation Fuel, 2016. <https://www.umweltbundesamt.de/en/publikationen/power-to-liquids-potential-perspectives-for-the>.
- [36] C. Panzone, R. Philippe, A. Chappaz, P. Fongarland, A. Bengaouer, Power-to-liquid catalytic CO<sub>2</sub> valorization into fuels and chemicals: focus on the Fischer-Tropsch route, *J. CO<sub>2</sub> Util.* 38 (2020) 314–347, <https://doi.org/10.1016/j.jcou.2020.02.009>.
- [37] C. Graves, S.D. Ebbesen, M. Mogensen, K.S. Lackner, Sustainable hydrocarbon fuels by recycling CO<sub>2</sub> and H<sub>2</sub> with renewable or nuclear energy, *Renew. Sustain. Energy Rev.* 15 (2011) 1–23, <https://doi.org/10.1016/j.rser.2010.07.014>.
- [38] S. Horvath, M. Fasihi, C. Breyer, Techno-economic analysis of a decarbonized shipping sector: technology suggestions for a fleet in 2030 and 2040, *Energy Convers. Manag.* 164 (2018) 230–241, <https://doi.org/10.1016/j.enconman.2018.02.098>.
- [39] Agora Verkehrswende, Agora Energiewende and Frontiers Economics: The Future Cost of Electricity-Based Synthetic Fuels, 2018 (accessed January 29, 2021), [www.agora-verkehrswende.de](http://www.agora-verkehrswende.de).
- [40] C. Beuttler, L. Charles, J. Wurzbacher, The role of direct air capture in mitigation of anthropogenic greenhouse gas emissions, *Front. Clim.* 1 (2019) 10, <https://doi.org/10.3389/fclim.2019.00010>.
- [41] M. Loewert, M. Riedinger, P. Pfeifer, Dynamically operated Fischer-Tropsch synthesis in PTL—Part 2: coping with Real PV profiles, *Chem. Eng.* 4 (2020) 27, <https://doi.org/10.3390/chemengineering4020027>.
- [42] M. Loewert, P. Pfeifer, Dynamically operated Fischer-Tropsch synthesis in PTL-part 1: system response on intermittent feed, *Chem. Eng.* 4 (2020) 21, <https://doi.org/10.3390/chemengineering4020021>.
- [43] S. Drünert, U. Neuling, T. Zitscher, M. Kaltschmitt, Power-to-liquid fuels for aviation – processes, resources and supply potential under German conditions, *Appl. Energy* 277 (2020) 115578, <https://doi.org/10.1016/j.apenergy.2020.115578>.
- [44] V. Dieterich, A. Buttler, A. Hanel, H. Spliethoff, S. Fendt, Power-to-liquid via synthesis of methanol, DME or Fischer-Tropsch-fuels: a review, *Energy Environ. Sci.* 13 (2020) 3207–3252, <https://doi.org/10.1039/d0ee01187h>.
- [45] H. Blanco, W. Nijs, J. Ruf, A. Faaij, Potential for hydrogen and power-to-liquid in a low-carbon EU energy system using cost optimization, *Appl. Energy* 232 (2018) 617–639, <https://doi.org/10.1016/j.apenergy.2018.09.216>.
- [46] R. Bacocchi, G. Storti, M. Mazzotti, Process design and energy requirements for the capture of carbon dioxide from air, *Chem. Eng. Process.* 45 (2006), <https://doi.org/10.1016/j.ccep.2006.03.015>.
- [47] W.K. Lewis, W.G. Whitman, Principles of gas absorption, *Ind. Eng. Chem.* 16 (1924) 1215–1220, <https://doi.org/10.1021/ie50180a002>.
- [48] S. Mioili, L.A. Pellegrini, S. Gamba, Simulation of CO<sub>2</sub> capture by MEA scrubbing with a rate-based model, *Procedia Eng.* 42 (2012) 1651–1661, <https://doi.org/10.1016/j.proeng.2012.07.558>.
- [49] Tractebel, Engie, Hincio, Study on Early Business Cases for H<sub>2</sub> in Energy Storage and More Broadly Power To H<sub>2</sub> Applications, 2017 [https://doi.org/fch.europa.eu/sites/default/files/P2H\\_Full\\_Study\\_FCHJU.pdf](https://doi.org/fch.europa.eu/sites/default/files/P2H_Full_Study_FCHJU.pdf).
- [50] F. Vidal Vázquez, P. Pfeifer, J. Lehtonen, P. Piermartini, P. Simell, V. Alopaeus, Catalyst screening and kinetic modeling for CO production by High pressure and temperature reverse Water gas shift for Fischer-Tropsch applications, *Ind. Eng. Chem. Res.* 56 (2017) 13262–13272, <https://doi.org/10.1021/acs.iecr.7b01606>.
- [51] M. Marchese, N. Heikkinen, E. Giglio, A. Lanzini, J. Lehtonen, M. Reinikainen, Kinetic study based on the carbide mechanism of a Co-Pt/γ-Al<sub>2</sub>O<sub>3</sub> Fischer-Tropsch catalyst tested in a laboratory-scale tubular reactor, *Catalysts* 9 (2019) 717, <https://doi.org/10.3390/catal9090717>.
- [52] M. Marchese, E. Giglio, M. Santarelli, A. Lanzini, Energy performance of power-to-liquid applications integrating biogas upgrading, reverse water gas shift, solid oxide electrolysis and Fischer-Tropsch technologies, *Energy Convers. Manag.* X (2020) 100041, <https://doi.org/10.1016/j.ecmx.2020.100041>.
- [53] F.J. Campanario, F.J. Gutiérrez Ortiz, Fischer-Tropsch biofuels production from syngas obtained by supercritical water reforming of the bio-oil aqueous phase, *Energy Convers. Manag.* 150 (2017) 599–613, <https://doi.org/10.1016/j.enconman.2017.08.053>.
- [54] P.M. Maitlis, A. de Klerk, Greener Fischer-Tropsch Processes for Fuels and Feedstocks, 2013, <https://doi.org/10.1002/9783527656837>.
- [55] Chemical Engineering, 2019 Chemical Engineering Plant Cost Index Annual Average, 2020.
- [56] D.W. Keith, G. Holmes, D.St. Angelo, K. Heidel, A process for capturing CO<sub>2</sub> from the atmosphere, *Joule* 2 (2018) 1573–1594, <https://doi.org/10.1016/j.joule.2018.05.006>.
- [57] G. Herz, E. Reichelt, M. Jahn, Design and evaluation of a Fischer-Tropsch process for the production of waxes from biogas, *Energy* 132 (2017) 370–381, <https://doi.org/10.1016/j.energy.2017.05.102>.
- [58] K. Antonios, K.D. Panopoulos, E. Kakaras, Investigation of technical and economic aspects for methanol production through CO<sub>2</sub>, *Int. J. Hydrogen Energy* 41 (2016) 2202–2214, <https://doi.org/10.1016/j.ijhydene.2015.12.074>.
- [59] J. Proost, State-of-the art CAPEX data for water electrolyzers, and their impact on renewable hydrogen price settings, *Int. J. Hydrogen Energy* 44 (2019) 4406–4413, <https://doi.org/10.1016/j.ijhydene.2018.07.164>.
- [60] R.U. Dietrich, F.G. Albrecht, S. Maier, D.H. König, S. Estelmann, S. Adelung, Z. Bealu, A. Seitz, Cost calculations for three different approaches of biofuel production using biomass, electricity and CO<sub>2</sub>, *Biomass Bioenergy* 111 (2018) 165–173, <https://doi.org/10.1016/j.biombioe.2017.07.006>.
- [61] W.L. Becker, R.J. Braun, M. Penev, M. Melaina, Production of Fischer-Tropsch liquid fuels from high temperature solid oxide co-electrolysis units, *Energy* 47 (2012) 99–115, <https://doi.org/10.1016/j.energy.2012.08.047>.
- [62] L.J.F. Comidy, M.D. Staples, S.R.H. Barrett, Technical, economic, and environmental assessment of liquid fuel production on aircraft carriers, *Appl. Energy* 256 (2019) 113810, <https://doi.org/10.1016/j.apenergy.2019.113810>.
- [63] M. Decker, F. Schorn, R.C. Samsun, R. Peters, D. Stolten, Off-grid power-to-fuel systems for a market launch scenario – a techno-economic assessment, *Appl. Energy* 250 (2019) 1099–1109, <https://doi.org/10.1016/j.apenergy.2019.05.085>.
- [64] F.J. Campanario, F.J. Gutiérrez Ortiz, Techno-economic assessment of bio-oil aqueous phase-to-liquids via Fischer-Tropsch synthesis and based on supercritical water reforming, *Energy Convers. Manag.* 154 (2017) 591–602, <https://doi.org/10.1016/j.enconman.2017.10.096>.
- [65] T.E. Akinola, E. Oko, M. Wang, Study of CO<sub>2</sub> removal in natural gas process using mixture of ionic liquid and MEA through process simulation, *Fuel* 236 (2019) 135–146, <https://doi.org/10.1016/j.fuel.2018.08.152>.
- [66] M.F. Shehzad, M.B. Abdelghany, D. Liuzza, V. Mariani, L. Glielmo, Mixed logic dynamic models for MPC control of wind farm hydrogen-based storage systems, *Inventions* 4 (2019) 57, <https://doi.org/10.3390/inventions4040057>.

- [67] M. Hillestad, M. Ostadi, G.d. Alamo Serrano, E. Rytter, B. Austbø, J.G. Pharoah, O. S. Burheim, Improving carbon efficiency and profitability of the biomass to liquid process with hydrogen from renewable power, *Fuel* 234 (2018) 1431–1451, <https://doi.org/10.1016/j.fuel.2018.08.004>.
- [68] IRENA, *Renewable Power Generation Costs in 2019: Latest Trends and Drivers*, 2019.
- [69] M. Fasihi, C. Breyer, Baseload electricity and hydrogen supply based on hybrid PV-wind power plants, *J. Clean. Prod.* 243 (2020) 118466, <https://doi.org/10.1016/j.jclepro.2019.118466>.
- [70] L. De Souza Noel Simas Barbosa, J.F. Orozco, D. Bogdanov, P. Vainikka, C. Breyer, Hydropower and power-to-gas storage options: the Brazilian energy system case, *Energy Procedia* (2016) 89–107, <https://doi.org/10.1016/j.egypro.2016.10.101>. Elsevier Ltd.
- [71] V. Dieterich, A. Buttler, A. Hanel, H. Spliethoff, S. Fendt, Power-to-liquid: via synthesis of methanol, DME or Fischer-Tropsch-fuels: a review, *Energy Environ. Sci.* 13 (2020) 3207–3252, <https://doi.org/10.1039/d0ee01187h>.
- [72] H2 energy to generate green hydrogen from hydropower in aarau, *Fuel Cells Bull.* 2016 (2016) 8, [https://doi.org/10.1016/s1464-2859\(16\)30181-x](https://doi.org/10.1016/s1464-2859(16)30181-x).
- [73] A. Hassan, M.K. Patel, D. Parra, An assessment of the impacts of renewable and conventional electricity supply on the cost and value of power-to-gas, *Int. J. Hydrogen Energy.* (2018), <https://doi.org/10.1016/j.ijhydene.2018.10.026>.
- [74] D. Parigi, E. Giglio, A. Soto, M. Santarelli, Power-to-fuels through carbon dioxide Re-utilization and high-temperature electrolysis: a technical and economical comparison between synthetic methanol and methane, *J. Clean. Prod.* 226 (2019) 679–691, <https://doi.org/10.1016/j.jclepro.2019.04.087>.
- [75] *Cost Estimation Methodology for NETL Assessments of Power Plant Performance DOE/NETL-2011/1455*, National Energy Technology Laboratory (NETL), 2019.
- [76] J. Gorre, F. Ortloff, C. Van Leeuwen, Production Costs for Synthetic Methane in 2030 and 2050 of an Optimized Power-to-Gas Plant With Intermediate Hydrogen Storage, 2019, <https://doi.org/10.1016/j.apenergy.2019.113594>.
- [77] F.G. Albrecht, D.H. König, N. Baucks, R.U. Dietrich, A standardized methodology for the techno-economic evaluation of alternative fuels – a case study, *Fuel* 194 (2017) 511–526, <https://doi.org/10.1016/j.fuel.2016.12.003>.
- [78] S. Martin, F.G. Albrecht, P. Van Der Veer, D. Liefink, R.U. Dietrich, Evaluation of on-site hydrogen generation via steam reforming of biodiesel: process optimization and heat integration, *Int. J. Hydrogen Energy* (2016) 6640–6652, <https://doi.org/10.1016/j.ijhydene.2016.02.138>. Elsevier Ltd.
- [79] T. Bhatelia, E. Li, Y. Sun, P. Hazewinkel, N. Burke, V. Sage, Chain length dependent olefin re-adsorption model for Fischer-Tropsch synthesis over Co-Al<sub>2</sub>O<sub>3</sub> catalyst, *Fuel Process. Technol.* (2014) 277–289, <https://doi.org/10.1016/j.fuproc.2014.03.028>.
- [80] K.L. Jensen, R.J. Menard, B.C. English, *Market Analysis for Fischer-Tropsch Waxes*, 2013 <https://doi.org/www.se-ibss.org>.
- [81] A. Chiodini, L. Bua, L. Carnelli, R. Zwart, B. Vreugdenhil, M. Vocciant, Enhancements in biomass-to-liquid processes: gasification aiming at high hydrogen/carbon monoxide ratios for direct Fischer-Tropsch synthesis applications, *Biomass Bioenergy* 106 (2017) 104–114, <https://doi.org/10.1016/j.biombioe.2017.08.022>.
- [82] IGrand View Research, *Global Paraffin Wax Market*, 2019.
- [83] G. Herz, E. Reichelt, M. Jahn, Techno-economic analysis of a co-electrolysis-based synthesis process for the production of hydrocarbons, *Appl. Energy* 215 (2018) 309–320, <https://doi.org/10.1016/j.apenergy.2018.02.007>.
- [84] J. Kärki, T. Thomasson, K. Melin, M. Suomalainen, H. Saastamoinen, M. Hurskainen, S. Mäkikouri, New business opportunities based on biogenic carbon dioxide utilization, 14th Greenh. Gas Control Technol. Conf. Melb. (2018).