

In-vivo monitoring for electrical expression of plant living parameters by an impedance lab system

*Original*

In-vivo monitoring for electrical expression of plant living parameters by an impedance lab system / Bar-On, L.; Peradotto, S.; Sanginario, A.; Motto Ros, P.; Shacham-Diamand, Y.; Demarchi, D.. - (2019), pp. 178-180. (Intervento presentato al convegno 26th IEEE International Conference on Electronics, Circuits and Systems, ICECS 2019 tenutosi a ita nel 2019) [10.1109/ICECS46596.2019.8964804].

*Availability:*

This version is available at: 11583/2858247 since: 2020-12-23T09:26:47Z

*Publisher:*

Institute of Electrical and Electronics Engineers Inc.

*Published*

DOI:10.1109/ICECS46596.2019.8964804

*Terms of use:*

This article is made available under terms and conditions as specified in the corresponding bibliographic description in the repository

*Publisher copyright*

IEEE postprint/Author's Accepted Manuscript

©2019 IEEE. Personal use of this material is permitted. Permission from IEEE must be obtained for all other uses, in any current or future media, including reprinting/republishing this material for advertising or promotional purposes, creating new collecting works, for resale or lists, or reuse of any copyrighted component of this work in other works.

(Article begins on next page)

# In-Vivo Monitoring for Electrical Expression of Plant Living Parameters by an Impedance Lab System

Lee Bar-on\*, Sebastian Peradotto<sup>†</sup>, Alessandro Sanginario<sup>†</sup>, Paolo Motto Ros<sup>†</sup>,  
Yosi Shacham-Diamand<sup>†</sup>, Danilo Demarchi\*,<sup>†</sup>

\*School of Electrical Engineering, Tel Aviv University, Tel Aviv, Israel

<sup>†</sup>Dept. of Electronics and Telecommunications, Politecnico di Torino, Torino, Italy

Email:leebaron@mail.tau.ac.il

**Abstract**—We present a complete in-lab system to monitor the plant and its surrounding environment. The plant impedance is directly measured in a continuous manner, while, simultaneously surrounding environment parameters known to affect plant status, are monitored. This is done combining a new in-vivo direct measurement of the plant together with an embedded system using available sensor technology and a designated interface for continuous data acquisition. Furthermore, the next versions this system can be deployed as a field monitoring device, with simple adaptations.

**Index Terms**—Plant Monitoring, Precision Agriculture, Plant IoT, In-Vivo Plant Sensor, Continuous Monitoring System

## I. INTRODUCTION

As world population increases and the demand for agricultural food produce grows, the need for closer monitoring of crops is increasing. This is incorporated into the term of precision agriculture [1], [2], [3], where more specific monitoring of crops is achieved based on available technology, whilst attempting to reduce crop loss due to environmental changes. Within this area, the concept of ‘Internet of Things’ for plants is discussed. Here, information is gathered from plants and their surroundings and sent to the cloud, where further data processing can be done and overall monitoring and care can be improved. The ability to promote these concepts is directly dependant on the availability of direct sensor technology and the ability to assess the acquired data, as well as the accessibility of the technology. One of the ways to promote plant monitoring is direct monitoring of plant changes, in conjunction with measurements of other environment parameters. Here, we suggest a complete lab system for monitoring in-vivo plant electrical changes[4], [5], as well as ongoing monitoring of the environment.

The need for a system that will allow for the collection of environmental data, using available sensor technology is apparent for research purposes, as well as determining the significance of new suggested technologies. The presented in-lab setup could easily be adapted to a portable field device [6], to allow data collection from the environment, whilst collecting measurements directly from the plant, using the newly suggested methods.

The direct measurement of the plant uses an impedance measurement covering a broad range of frequencies, whilst the environment is measured using off the shelf available components. The setup allows for continuous study of environmental changes that will later be studied in coordination with measurements of the plant impedance. A combination of the newly acquired data directly from the plant, and known environmental changes will open way for improving plant monitoring and care within the field of precision agriculture. In addition, the electrical changes measured directly from the plant, rather than the surrounding environment may allow improved plant care and better evaluation of the plant status.

## II. EXPERIMENTAL SETUP

A system of sensors to collect information on the environmental status was set up (figure 1). It allows continuous data collection of the surrounding plant environment, and samples every 15 minutes. The system is controlled and programmed using a Python interface and the hardware is based on the RaspberryPi<sup>©</sup> platform [7].

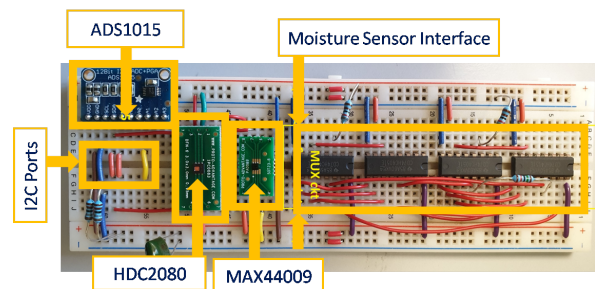

Fig. 1. Generic Sensors setup connected indicating the  $I^2C$  ports that are then connected to the RaspberryPi<sup>©</sup>

The system includes three generic sensors:

- 1) HDC2080 (Texas Instruments Ltd) - temperature and relative air humidity sensor [8];
- 2) MAX44009 (Maxim Integrated Ltd) - ambient light sensor monitoring [9];
- 3) 200SS WATERMARK Sensor (Irrrometer Ltd) - soil moisture monitoring [10].

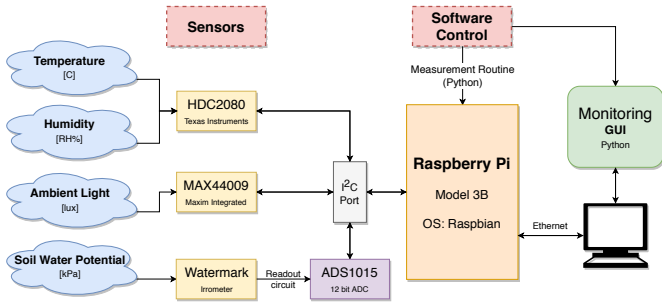

Fig. 2. Sensor system block diagram

The sensors are all connected to the *GPIO* port of the RaspberryPi<sup>®</sup> [7] using the *I<sup>2</sup>C* protocol (port #1). While the moisture sensor requires an analog to digital converter and a readout circuit. The circuit is constituted by the schematics and components recommended by the manufacturer [11], also using the *I<sup>2</sup>C* protocol and sharing the port with the previously mentioned sensors. The complete supporting circuit allows to control and collect data in a synchronized manner, while having the readout from each sensor collected serially every 15 minutes and saved to a data file. A block diagram of the system is shown in figure 2.

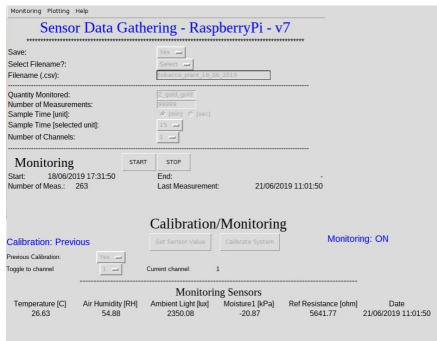

Fig. 3. User Interface

The system is controlled using a Python interface, developed for data collection and monitoring. It is connected via a PC using an Ethernet connection. The user controlled interface is shown in figure 3. The collected data is also displayed in real time, as in figure 4.

Simultaneously, impedance measurements using a four terminal setup connected directly to the plant stem, are run. An impedance analyzer (Keysight Technologies model 4294A) is connected and controlled by a designated LabView<sup>®</sup> software [12] interface. Measurements are conducted every 15 minutes and data is collected using LabView<sup>®</sup> software [12]. A diagram of the system can be seen in figure 5.

The direct sensing from the plant is done using an in-vivo method [4], [5] for impedance measurements with gold electrodes. These are inserted into the plant stem. Here a young Tobacco plant has been monitored over time.

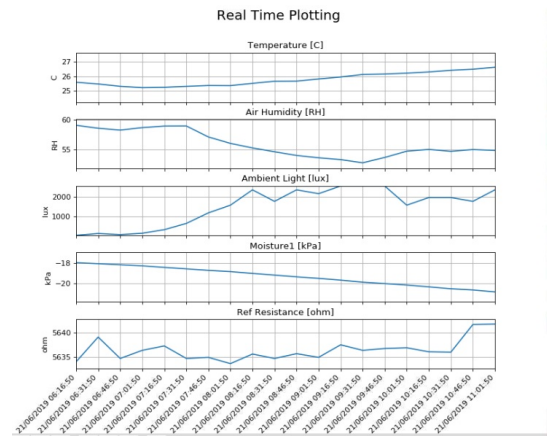

Fig. 4. Example of real time data acquired from the sensing system and presented graphically

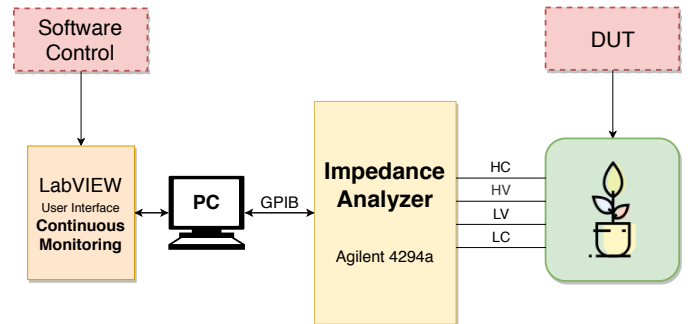

Fig. 5. Plant Monitoring system block diagram controlled by LabView<sup>®</sup> interface

### III. CONTROLLED NUTRIENTS SETUP

In addition to the presented configuration, the suggested system can be used with a controlled plant growth environment. In this case the soil can be replaced with agar gel, where the concentration of nutrients to the plant can be completely controlled. In this case, instead of assessment based on watering needs and amount of soil.

This configuration will allow for better control of plant environment for research uses as well as improved understanding of the electrical response withing the plant, as a function of different nutrients in the soil.

### IV. RESULTS AND DISCUSSION

Continuous measurements were completed over a time period of 3-5 days each time. Impedance was run over frequencies in the range of 40 Hz – 1 MHz, collecting data four times in every hour.

A summary of the measured impedance values for a distance of 20 cm across the plant stem, and standard deviations for some specific frequencies can be seen in Table I.

Observation of the data shows that a day, i.e. 24 hours, can be divided into time slots in which changes in measured impedance are visible. These changes are smaller than the standard deviation of the mean value, yet are not continuous

TABLE I  
IMPEDANCE MEAN VALUES OF TOBACCO PLANT

Frequency [Hz]	Modulus [k $\Omega$ ]	Angle [deg]
100	94755 $\pm$ 6320	-9 $\pm$ 0.68
1000	74388 $\pm$ 3882	-24.3 $\pm$ 0.93
10000	27320 $\pm$ 1024	-44 $\pm$ 0.51
100000	7855 $\pm$ 153	-49.5 $\pm$ 0.98

across all time slots. Therefore additional data acquisition and further study are needed. These results can be seen in figure 6.

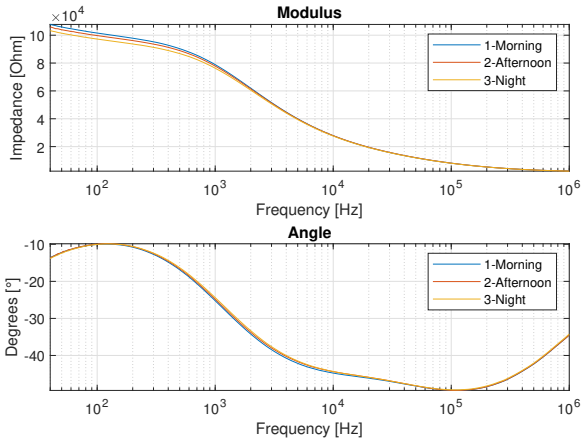

Fig. 6. Impedance plot during different times of the day

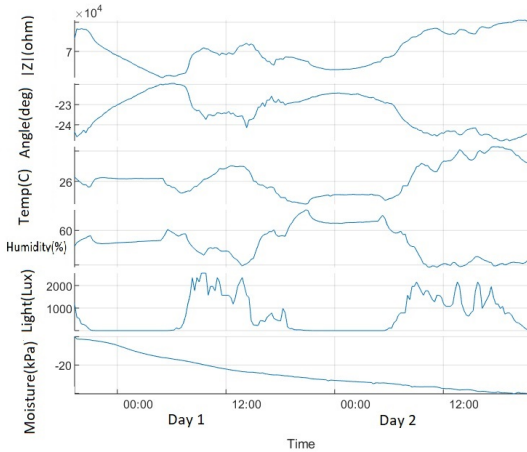

Fig. 7. Results of impedance and all sensor data from the system monitored over 2 days, around the centroid frequency

Then, examination of the data collected from our environment sensors system was done, in conjunction with data collected directly from the plant. An example of data gathered from both the plant and the sensor system, across a 2 day time window is shown in figure 7. The impedance data is shown at the centroid frequency, showing fluctuations over time. In

addition, daylight hours and the constant decrease in moisture are easily visible. Yet, further study of the change dependency of the different parameters and the response time within the plant to these changes, is needed.

Clearly, it can be seen that the system will allow research and study of environment changes in the plant surroundings, while examining plant impedance changes. The system allows the gathering of large amounts of data for an in depth study of these changes.

## V. CONCLUSIONS

We have presented an in-lab generic experimental system for continuous monitoring of the plant and its surrounding environment to provide a basis for study of physiological changes in the plant related to environmental changes. The system will allow to study change in electrical response of the plant directly, with possibility of learning the dependencies on the different surrounding environment parameters.

The presented setup is also adaptable to serve as a field sensor system combined with different sensing technologies being developed and will open way for direct measurement of plants and data gathering for Internet of Things, that is the plan for the continuation of this research work.

## ACKNOWLEDGEMENT

The authors would like to thank Prof. Adi Avni of the Faculty of Life Sciences, at the Tel Aviv University, Tel Aviv, Israel. The authors would like to thank Prof. Roberto Jona and Prof. Ivana Gribado of the Institute for Sustainable Plant Protection, National Research Council, Grugliasco (TO), 10095, Italy. The authors would like to thank the *Italian Ministry of Foreign Affairs and Cooperation* for collaboration grant 2018-2019.

## REFERENCES

- [1] A. Luvisi, "Electronic identification technology for agriculture, plant, and food. a review," *Agronomy for Sustainable Development*, vol. 36, no. 1, p. 13, Feb 2016.
- [2] A. Walter, R. Finger, R. Huber, and N. Buchmann, "Opinion: Smart farming is key to developing sustainable agriculture," *Proceedings of the National Academy of Sciences*, vol. 114, no. 24, pp. 6148–6150, 2017. [Online]. Available: <https://www.pnas.org/content/114/24/6148>
- [3] S. Fritz, L. See, J. C. L. Bayas, F. Waldner, and D. Jacques, "A comparison of global agricultural monitoring systems and current gaps," *Agricultural Systems*, vol. 168, pp. 258–272, 2019.
- [4] L. Bar-on, A. Jog, and Y. Shacham-Diamand, "Four Point Probe Electrical Spectroscopy Based System for Plant Monitoring," *2019 IEEE International Symposium on Circuits and Systems (ISCAS)*, pp. 1–5, 2019.
- [5] P. M. Ros, E. Macrelli, A. Sanginario, Y. Shacham-Diamand, and D. Demarchi, "Electronic System for Signal Transmission Inside Green Plant Body," *2019 IEEE International Symposium on Circuits and Systems (ISCAS)*, pp. 1–5, 2019.
- [6] A. Jog and Y. Shacham-Diamand, private communication.
- [7] Raspberry Pi Foundation, "Raspberry Pi 3B." [Online]. Available: <https://www.raspberrypi.org/products/raspberry-pi-3-model-b/>
- [8] Texas Instruments, "HDC2080 Low Power Humidity and Temperature Digital Sensor," 2018.
- [9] Maxim Integrated, "MAX44009 Industry's Lowest-Power Ambient Light Sensor," pp. 1–20, 2011.
- [10] Irrometer, "Model 200SS WATERMARK Soil Moisture Sensor," 1978.
- [11] Texas Instruments, "AD1015." [Online]. Available: <http://www.ti.com/product/ADS1015#>
- [12] National Instruments, "Labview Software." [Online]. Available: <http://sine.ni.com/np/app/main/p/docid/nav-104/lang/it/fmid/1765/>