

NFV Platforms: Taxonomy, Design Choices and Future Challenges

Original

NFV Platforms: Taxonomy, Design Choices and Future Challenges / Zhang, Tianzhu; Qiu, Han; Linguaglossa, Leonardo; Cerroni, Walter; Giaccone, Paolo. - In: IEEE TRANSACTIONS ON NETWORK AND SERVICE MANAGEMENT. - ISSN 1932-4537. - STAMPA. - 18:1(2021), pp. 30-48. [10.1109/TNSM.2020.3045381]

Availability:

This version is available at: 11583/2859733 since: 2021-01-06T10:49:18Z

Publisher:

IEEE

Published

DOI:10.1109/TNSM.2020.3045381

Terms of use:

This article is made available under terms and conditions as specified in the corresponding bibliographic description in the repository

Publisher copyright

IEEE postprint/Author's Accepted Manuscript

©2021 IEEE. Personal use of this material is permitted. Permission from IEEE must be obtained for all other uses, in any current or future media, including reprinting/republishing this material for advertising or promotional purposes, creating new collecting works, for resale or lists, or reuse of any copyrighted component of this work in other works.

(Article begins on next page)

NFV Platforms: Taxonomy, Design Choices and Future Challenges

Tianzhu Zhang, Han Qiu, *Member, IEEE*, Leonardo Linguaglossa, *Member, IEEE*,
Walter Cerroni, *Senior Member, IEEE*, Paolo Giaccone, *Senior Member, IEEE*

Abstract—Due to the intrinsically inefficient service provisioning in traditional networks, Network Function Virtualization (NFV) keeps gaining attention from both industry and academia. By replacing the purpose-built, expensive, proprietary network equipment with software network functions consolidated on commodity hardware, NFV envisions a shift towards a more agile and open service provisioning paradigm. During the last few years, a large number of NFV platforms have been implemented to facilitate the development, deployment, and management of Virtual Network Functions (VNFs). Nonetheless, just like any complex system, such platforms commonly consist of abounding software and hardware components and usually incorporate disparate design choices based on distinct motivations or use cases. This broad collection of convoluted alternatives makes it extremely arduous for network operators to make proper choices. Although numerous efforts have been devoted to investigating different aspects of NFV, none of them specifically focused on NFV platforms or attempted to explore their design space. In this paper, we present a comprehensive survey on the NFV platform design. Our study solely targets existing NFV platform implementations. We begin with a top-down architectural view of the standard reference NFV platform and present our taxonomy of existing NFV platforms based on what features they provide in terms of a typical network function life cycle. Then we thoroughly explore the design space and elaborate on the implementation choices each platform opts for. We also envision future challenges for NFV platform design in the incoming 5G era. We believe that our study gives a detailed guideline for network operators or service providers to choose the most appropriate NFV platform based on their respective requirements. Our work also provides guidelines for implementing new NFV platforms.

Keywords—*Network Function Virtualization, Service Function Chaining, Service Management and Orchestration, NFV Infrastructure, VNF Life Cycle*

I. INTRODUCTION

Traditionally, network services are provisioned using purpose-built, proprietary hardware appliances (or middle-

boxes). Middleboxes embody a large variety of specialized functions to forward, classify, or transform traffic based on packet content. Examples of middleboxes include L2 switching, L3 Routing, Network Address Translation (NAT), Firewall (FW), Deep Packet Inspection (DPI), Intrusion Detection System (IDS), Load Balancers (LB), WAN optimizers, and stateful proxies. Nowadays, middleboxes are ubiquitous in enterprise networks [1]. With the increasingly diversified user requirements, as well as the rapid growth of Internet traffic in terms of both volume and heterogeneity [2], hardware middleboxes begin to exhibit several fundamental disadvantages. First off, middleboxes are generally expensive to acquire and it usually requires domain-specific knowledge to manage them, resulting in large capital expenditure (CapEx) and operational expenditure (OpEx). Also, adding customized functionalities is extremely time-consuming if not impossible, and it sometimes takes an entire purchase cycle (e.g. four years) to bring in equipment with new features [3]. Such tight coupling with the hardware production cycle considerably hampers network innovation and prolongs time-to-market. Deploying new Network Services (NSs) is also a tedious process, as technicians are required to visit specific sites and place the middleboxes in a pre-defined order to form the correct Service Function Chains (SFCs). Service instantiation might even take days. Worse still, service maintenance usually involves constant repetition of the same process. Furthermore, because of the inherent inflexibility, it is not trivial for hardware middleboxes to elastically scale in and out based on the shifting demand or other system dynamics. Consequently, network operators usually resort to peak-load (over-)provisioning, which in turn leads to inefficient resource utilization and high energy consumption.

To improve resource utilization and overcome the network ossification, telecommunication operators began to pursue new solutions that can guarantee both cost-effectiveness and flexi-

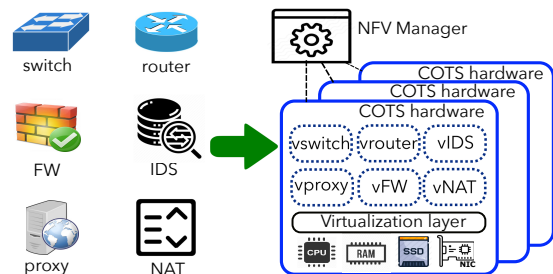

Fig. 1: Traditional vs. NFV paradigm

T. Zhang was with the Department of Network and Computer Science, Telecom Paris. He is now with Nokia Bell Labs, 91620 Nozay, France. (email: tianzhu.zhang@nokia-bell-labs.com)

H. Qiu and L. Linguaglossa are with the Department of Network and Computer Science, Telecom Paris, 91120 Paris, France. (email: han.qiu@telecom-paris.fr, linguaglossa@telecom-paris.fr)

W. Cerroni is with the Department of Electrical, Electronic, and Information Engineering “Guglielmo Marconi,” University of Bologna, 40136 Bologna, Italy. (email: walter.cerroni@unibo.it)

P. Giaccone is with Consorzio Nazionale Interuniversitario per le Telecomunicazioni (CNIT), 43124, Parma, Italy and with the Department of Electronics and Telecommunications, Politecnico di Torino, 10138 Torino, Italy. (email: paolo.giaccone@polito.it)

bility. The advent of Software Defined Networking (SDN) [4] and Network Function Virtualization (NFV) [5] opened new alternative approaches for network management and service provisioning. SDN decouples the control plane from the data plane and leverages a logically centralized controller to configure the programmable switches based on a global view, while NFV aims at replacing specialized middleboxes with software-based Virtual Network Functions (VNFs) deployed on Commodity Off-The-Shelf (COTS) hardware. The key to their success lies in separating the evolution timeline of software network functions from that of specialized hardware, completely unleashing the potential of the former. An illustrative example contrasting the NFV paradigm with traditional network infrastructures is shown in Fig. 1. Compared to the traditional service provisioning paradigm based on hardware middleboxes, NFV manages to achieve cost-effectiveness by leveraging multiple instances of VNFs on high-volume yet less expensive COTS servers, routers, or storage. Service provisioning in NFV is thus highly simplified, as the previously mentioned troublesome tasks, such as middlebox deployment, monitoring, migration, and scaling, can be optimally automated and flexibly managed through software control mechanisms. It is thus convenient for NFV solutions to exploit available resources and management tools typical of cloud or edge computing infrastructures. In addition, NFV remarkably promotes network innovation and accelerates the time-to-market process as network function development is cut down to writing software programs using standard application programming interfaces (APIs).

Thanks to these benefits, NFV keeps gaining momentum from both industry and academia. The first concerted effort towards NFV standardization began in 2012, with the appointment of the Industry Specification Group on NFV as part of the European Telecommunications Standards Institute (ETSI) [6]. Currently, ETSI consists of more than 500 members across the world, including major telecommunication operators, service providers, manufacturers, as well as universities. Meanwhile, the continuous advancement of COTS hardware capabilities and the emergence of high-speed packet processing techniques have managed to reduce the previously huge performance gap between software network functions and specialized middleboxes. Resources of other hardware components, such as Graphics Processing Unit (GPU) and in-path programmable network devices, can also be exploited to share the workload and alleviate the CPU burden. These technical opportunities considerably stimulate the growth of NFV and foster its adoption by telecom operators. During the last eight years, a large variety of NFV platforms have been developed and implemented to spur the innovation and evolution of NFV.

However, just like any complex system, existing NFV platforms usually encompass many closely interacting software and hardware components and embrace divergent design choices driven by their respective motivations, use cases, and application fields. To deal with the non-trivial network function life cycle, the design space of these platforms can be very wide, with choices ranging from high-level VNF development to low-level infrastructure details. The former category includes VNF execution models, state management schemes, or genres of APIs, while the latter category includes system design

choices like packet I/O frameworks, VNF interconnecting methods, or virtualization technologies, as well as various datapath acceleration techniques such as batch processing, zero-copy packet transfer, data prefetching, and computation offloading. Such a broad range of platform implementations coupled with even more extensive design space makes it extremely difficult (if not impossible) for network operators to choose the most suitable solution to their needs. The tradeoffs and caveats between different design choices are also unclear, making new platforms laborious and error-prone to implement.

This paper presents a comprehensive survey of existing NFV platforms and their design. The main contributions can be summarized as follows:

- We conduct a literature review and classify the existing NFV platforms according to what features they provide in terms of a typical VNF life cycle. We also briefly review the internals of each platform.
- We explore the NFV design space and discuss the various design choices adopted by existing platforms.
- We discuss potential challenges of bringing Artificial Intelligence (AI), network slicing, and Internet of Things (IoT) into NFV.

Several existing literature surveys investigated some particular aspects of NFV, including VNF placement [7], resource allocation [8], fault management [9], service function chaining [10], and security [11], but none of them specifically focused on the design aspects of NFV platforms from a VNF life cycle perspective, nor did they attempt to explore the design space or review different implementation choices. In [12], the authors investigated several industrial NFV Management and Orchestration (MANO) projects, whereas our work additionally considers the NFV management frameworks from academia. In [13] and [14], a subset of the state-of-the-art NFV platforms were generally reviewed, while our work considers, to the best of our knowledge, all the existing platforms and focuses on their tailored implementation.

This paper is organized as follows: in Sec. II, we give an architectural overview of the components of NFV platforms. Then we present our taxonomy on existing platforms in Sec. III based on a typical VNF life cycle. In Sec. IV, we propose a collection of critical design choices and survey the solutions adopted by different platforms. We envision future directions and draw our conclusion in Secs. V and VI, respectively.

II. NFV PLATFORM: AN ARCHITECTURAL OVERVIEW

We devote this section to presenting a general architectural overview of a typical NFV platform and to reviewing the key components in depth. Although a reference architecture has been defined by the ETSI specification [15], most of the existing NFV platforms did not strictly follow it. For example, some key ETSI components were not implemented by some industrial NFV platforms [12], whereas other implementations focused only on partial management aspects. As a result, we seek to combine the ETSI reference architecture with those of the existing platforms and present a generic view, as illustrated in Fig. 2. An NFV platform generally consists of three primary components, namely the NFV MANO plane,

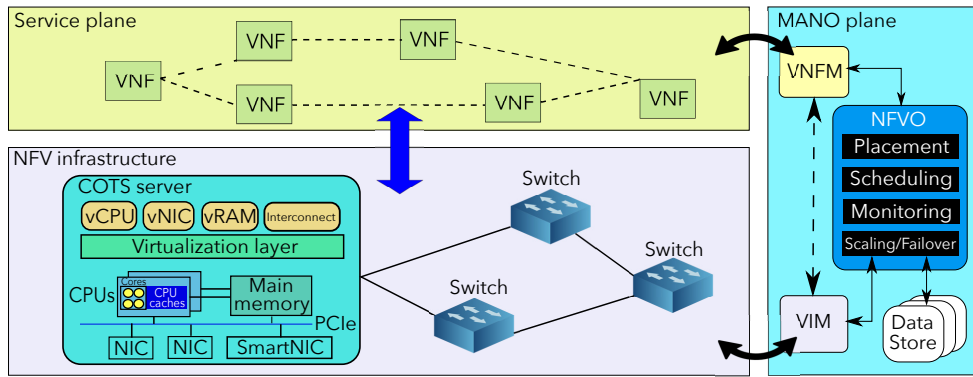

Fig. 2: The architecture of a general NFV platform

the service plane, and the NFV Infrastructure (NFVI). The MANO plane provides centralized control over service provisioning and management. The NFVI contains a collection of computation, storage, and network resources that are distributed across different infrastructural nodes. MANO plane components systematically monitor and schedule the resources to build a virtualized environment and accommodate different network services. The service plane contains a diversified collection of VNFs that are ordered in the form of service chains to fulfill the desired network services. These service chains are also carefully monitored and adjusted by the MANO plane components to efficiently multiplex the NFVI resources. In general, the service plane is enabled through concerted operations from both the MANO plane and NFVI.

A. MANO plane

The NFV MANO plane is the central point for service provisioning in NFV. A MANO system typically consists of three sub-systems: NFV Orchestrator (NFVO), Virtualized Infrastructure Manager (VIM), and VNF Manager (VNFM). As shown in Fig. 2, the NFVO is responsible for the instantiation, management, and termination of network services. At present, an NFVO commonly encompasses different modules to apply different MANO operations. On the right part of Fig 2, we illustrate four example modules. The placement module is in charge of rendering the best deployment, possibly in an incremental fashion. When new services need to be deployed, the placement module analyzes the service descriptions or requirements specified by network operators, constructs an aggregated service representation (e.g., service processing graph), performs necessary optimizations (e.g., function merging, redundant elimination), and calculates the best possible placement strategy by determining the nodes on which to deploy the related VNFs and their chaining order. The monitoring module is responsible for collecting statistics and events from both the service plane and the infrastructure and provides runtime feedback to other NFVO modules. Based on the traffic condition and resource utilization collected on-the-fly, the placement module can recalculate a new placement to achieve better performance. The scheduling module can

dynamically make fine-grained resource allocation to attain resource efficiency. The scaling/failover module can also collaborate with the placement module to scale in/out particular VNFs or service chains to accommodate traffic fluctuations or instantiate new VNF replicas upon failure. Based on the decisions made by the aforementioned modules, the NFVO interacts with other MANO plane components to realize the intended service configurations and resource allocations.

The VIM is designed to configure infrastructure components to accommodate the heterogeneous VNFs or service chains instantiated in the service plane. In specific, it directs the provision/release/upgrade of NFVI resources and manages the mapping between virtual and physical resources. It also manages the data path for network services by creating/deleting/updating virtual interfaces and logical links and collects the NFVI software and hardware resource status on behalf of the NFVO monitoring module. Note that a VIM instance might control either all the resources of the whole NFVI or those of multiple NFVI-Nodes. In some cases, a VIM might also just control a specific type of resource.

On the other hand, VNFM interacts with the service plane and takes care of the lifecycle (i.e., instantiating, scaling, upgrading, and terminating) of individual VNFs and service chains. It also needs to synchronize with VIMs to allocate or release the related infrastructural resources. According to ETSI specification, the MANO system might also maintain several data stores to hold configuration information such as network service descriptors, VNF templates, NFVI resource repositories, etc.

B. NFV Infrastructure

The NFV Infrastructure (NFVI) contains all the essential hardware and software components to compose virtual network services. The infrastructure might belong to Internet service providers, cloud/edge operators, or simply infrastructure providers. It usually embodies a large variety of computing nodes and network equipment. Each computing node or network equipment is commonly referred to as NFVI-Node. Network equipment in NFVI can be traditional purpose-built switches/routers or the emerging programmable switches that

can be remotely orchestrated with SDN or P4 [16] semantics. The most typical form of computing nodes in NFVI is represented by COTS servers. These servers normally contain several critical hardware components, including multicore CPUs, the main memory, and the physical Network Interface Controllers (NICs), which are interconnected through PCI buses. The physical NICs are capable of operating at Gigabit rates with multiple queues promoting parallelization. High-speed packet I/O techniques are also integrated by the NICs to transport packets to the service plane. Inside the server, multi-core CPUs are distributed across non-uniform memory access (NUMA) nodes to speed up traffic processing. Aside from CPU, other computing units such as smartNICs and GPUs are also widely utilized by existing NFV platforms to further boost performance. The virtualization layer in the COTS server provides the environment to accommodate network functions. The virtualization can be at the hardware level relying on bare-metal hypervisors or at the OS level using container engines. Some platforms even execute network functions as ordinary processes, which are addressed as Physical Network Functions (PNFs) in some works. In this paper, we universally refer to them as VNFs for the sake of simplicity. To ensure efficient communication between the VNFs and the external network, virtual interconnects need to be precisely established. This is typically accomplished using state-of-the-art software-based virtual switches or customized forwarding tables. Note that we consider physical links between COTS servers and network equipment as part of the NFVI as well.

C. Service plane

The service plane is populated with a variety of VNFs implementing different processings to constitute various network services. The distribution of VNFs inside virtual environments is quite flexible. For instance, a VNF or a whole service chain can be mapped to a single VM for execution, but a VNF can also be split into finer-grained processing elements and deployed across multiple NFVI-Nodes. In addition, VNFs are usually constructed using different programming abstractions and operate in different runtime execution models. Some platforms provide complete primitives to build and manage stateful VNFs or SFCs.

III. TAXONOMY OF NFV PLATFORMS

Our taxonomy of NFV platforms follows the typical life cycle of network functions, as shown in Fig. 3. The initial step is *prototyping*, which implements the first instances of the desired network functions. Then it follows the extensive *testing* phase to validate the correctness and performance of the implemented functions. Afterward, during the *deployment* phase, the network functions are instantiated for execution in the production environment. Finally, the *management and execution* phase ensures smooth service provisioning by taking care of different management issues and execution optimizations at runtime. Based on our literature review, most of the existing NFV platforms are specially purposed to facilitate a particular phase in the life cycle. Therefore, we opted to classify existing NFV platforms according to their *main focus*

for the VNF life cycle. Note that the *integrated NFV platforms* aim at actualizing end-to-end service provisioning and thus take care of multiple phases in the life cycle, we discuss them in detail at the end of this section.

The remainder of this section is organized as follows. Sec. III-A focuses on the design and implementation of network functions. In Sec. III-B, we discuss NFV platforms purposed to validate and benchmark the implemented network functions. We devote Sec. III-C to discussing NFV platforms that specifically target the problem of deployment. In Sec. III-D, we review platforms dealing with the management and execution of VNFs and SFCs. Finally, we discuss the integrated NFV platforms in Sec. III-E.

A. Prototyping

Rapid prototyping massively reduces the time-to-market of network services and plays a critical role in the growing popularity of NFV. Existing NFV platforms usually undertake two approaches to spur VNF development. The first approach is embracing *modular design* by pre-building a set of simple, loosely-coupled, and extensible network functions for developers to implement more advanced network services without reinventing the wheel. The second approach is employing *complexity abstraction* to deal with the intricacies of the VNF execution environment and let the developers concentrate on implementing the essential VNF processing logics.

Modular design: Several existing NFV platforms specifically follow the modular design approach. In particular, **xOMB** [17] is among the earliest endeavors for building scalable, programmable, and performant network functions on COTS servers. It provides a set of programmable modules and allows them to be arranged into a general pipeline to implement the expected network services. **NetBricks** [18] facilitates the VNF development process by implementing a small set of core processing elements that are highly optimized and customizable through user-defined functions. It also employs safe language, an efficient runtime library, and unique types to ensure the execution and performance isolation of the implemented VNFs. μ **NF** [19] builds SFCs using disaggregated, reusable components, and employs a centralized orchestrator to convert service policies to equivalent forwarding graphs. It further instructs per-server agents to install and manage the VNFs. Some platforms even provide modular transport stack to develop network functions at the application layer. For example, **Microboxes** [20] implements a modular, customizable, asynchronous TCP stack for each flow to avoid redundant SFC processing. It also provides a publish/subscribe channel to chain network functions and realize complex network services. **ClickNF** [21] augments the Click router [22] with a modular TCP stack to build L2-L7 VNFs and devises a blocking socket to ease VNF development difficulty imposed by traditional asynchronous non-blocking paradigm.

Complexity abstraction: Existing NFV platforms commonly provide high-level abstractions of the underlying function execution environment to relieve developers from the peripheral

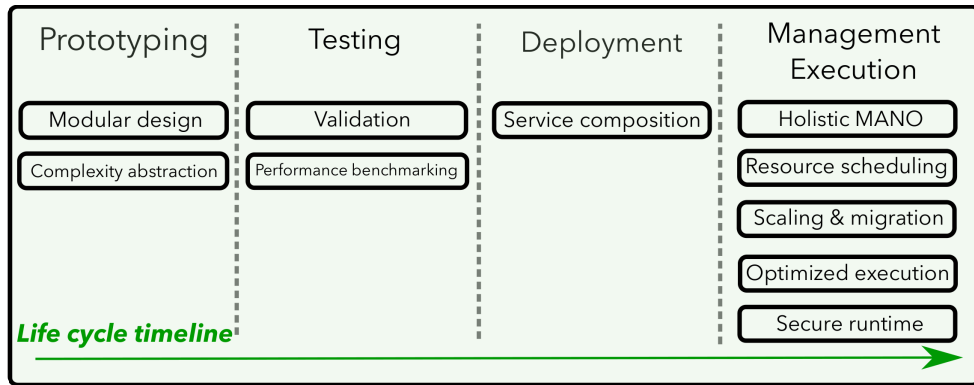

Fig. 3: Our taxonomy is inspired by the typical life cycle of network functions, namely: prototyping, testing, deployment, management and execution. We highlight in boxes some of the principles and objectives, and their main positioning within the network function life cycle.

but tedious tasks such as packet I/O, traffic classification, state management, task coordination, and resource allocation. In particular, **NFMorph** [23] decouples VNF logics from packet processing optimizations and proposes a domain-specific language with coherent processing pipelines. It also optimizes VNF execution based on the runtime workload and system constraints. **Polycube** [24] builds reconfigurable SFCs in kernel space. It separates the processing pipeline into a fast kernel path and a slow path and exposes an API to handle fast-/slow-path processing and system events. The fast path leverages extended Berkeley Packet Filter (eBPF) [25] to sustain high speed, while the slow path provides more advanced, complex processing in user-space. Some platforms aim at providing APIs to realize customized processing for individual traffic classes. For instance, **FlowOS** [26] exposes an API for VNF developers to implement customized processing for each packet flow without dealing with the low-level complexities such as inter-process communication and raw packet I/O. **Scylla** [27] is a declarative language for per-flow custom processing in wireless networks. It also provides a set of programming abstractions to express management intents, which are realized in NFVI by Scylla runtime. **MiddleClick** [28] aims at building high-speed, parallelized service chains. It provides APIs for network operators to define SFC intents which are synthesized into a flow table. A session abstraction is also implemented to facilitate per-flow inspection.

Some platforms provide APIs to automatically manage VNF execution states. For instance, **libVNF** [29] implements a generic library to assist the development of VNFs ranging from L2/L3 middleboxes to transport-/application-layer endpoints, with the support of seamless integration of the kernel and third-party network stacks. A request object abstraction is proposed to maintain application states across multiple non-blocking, event-driven callbacks. The libVNF API is also capable of interacting with multi-level data stores for state management across threads of a single VNF or multiple VNF replicas. **StatelessNF** [30] embraces the separation of concerns design by decoupling the VNF states from processing so that devel-

opers only need to concentrate on VNF-specific logic, while StatelessNF arranges for state replication and management tasks. The VNF states are maintained in a distributed key-value data store that guarantees low-latency access and data resilience. **S6** [31] extends distributed state objects (DSO) with a programming model to build scalable VNFs. S6 runtime manages shared VNF states distributed in DSO space. S6 also employs several optimizations including micro-threaded scheduling and DSO space reorganization. **NFVector** [32] employs the distributed actor model to support per-flow abstraction and provides APIs to implement VNFs with resilience. **NetStar** [33] implements a flow-based asynchronous interface combined with a future/promise library for VNF development. Instead of spreading control logic across multiple callback functions, NetStar mimics sequential execution by chaining multiple future objects and functions over a single call.

B. Testing

After the prototyping phase, an extensive testing campaign is required to validate the correctness and performance of the newly developed VNFs. In this section, we review existing NFV platforms specially designed for execution validation as well as performance benchmarking.

Validation: A few NFV platforms adopt code analysis to validate the correctness of VNFs and SFCs. For example, **SFC-Checker** [34] is a diagnosis framework to verify the correctness of SFC forwarding behaviors. It extends OpenFlow to represent each VNF with a Match/Action table and a state machine and builds a stateful forwarding graph to capture both forwarding behaviors and state transitions so that SFC forwarding behaviors can be verified under different traffic conditions. **BUZZ** [35] is a testing framework that models complex network functions as finite-state machines to detect policy violations. It also employs an optimized symbolic execution to achieve high scalability. **ChainGuard** [36] is an independent tool for static SFC verification in the dynamic cloud environment. It leverages flow tables to model the processing and forwarding behaviors for the SFCs and implements

a graph traversing algorithm for verification. **NFactor** [37] automatically synthesizes a VNF model through code analysis to verify network policy and service chaining.

Performance benchmarking: There is a broad range of platforms designed to benchmark the performance of the newly developed VNFs and SFCs. Some of them mainly focus on performance monitoring in different environments. For instance, **ConMon** [38] is a distributed framework to monitor the performance of containerized VNFs. It dynamically discovers and monitors the communication between containers, and executes network monitoring functions inside a standby container interconnected through a virtual switch. **KOMon** [39] is a kernel-based online monitoring tool to measure packet processing times imposed by the target VNF. **NFVPerf** [40] detects performance bottlenecks for a SFC by monitoring inter-VNF communication. **VBaaS** [41] envisions a Benchmark-as-a-Service platform to perform runtime performance profiling on VNFs and NFVI. **OPNFV Barometer** [42] is designed to monitor the performance of DPDK-accelerated VNFs. It can be attached to the target VNF as a secondary process to gather data plane information. **NFV-VIPP** [43] can be integrated into the DPDK-accelerated data plane to collect execution metrics and demonstrate the internals of an NFVI node.

Besides performance monitoring, some platforms are also capable of performance analysis. **NFV-vital** [44] interprets deployment and workload configurations to setup VNFs and generate workload. It also receives runtime statistics for posttest analysis. **Gym** [45] is designed for automatic VNF performance benchmarking. It embraces a modular architecture with an extensible set of benchmarking tools and a simple messaging subsystem for remote procedure calls. It further provides a means for data post-processing and result visualization. **Du et al.** [46] build a benchmarking framework on the OPNFV clearwater platform. They leverage the microservices architecture to integrate existing open-source tools to realize comprehensive tests under varied traffic loads and fault conditions. **Symperf** [47] predicts VNF runtime performance and functional behaviors under various traffic dynamics through code analysis. **Perfsight** [48] aggregates runtime information from data path to diagnose performance issues. **SFCPerf** [49] uses a control module to parse service descriptions and deploy the corresponding SFCs in NFVI. The control module also collects critical statistics for data analysis and visualization. In [50], the authors proposed **NFV-Bench**, a benchmarking solution capable of performing dependability and performance evaluations for NFV solutions, and presented a case study on two state-of-the-art virtualization techniques. **BOLT** [51] defines the concept of the performance contract, which expresses the expected VNF or SFC performance as a function of critical parameters (e.g., execution instructions, CPU cycles, memory accesses). **DeepDiag** [52] monitors the runtime queuing statistics for each VNF and constructs an online impact graph to diagnose the cause of performance degradation. **CASTAN** [53] adopts symbolic execution to identify the worst code path and a CPU cache model to determine memory access patterns that cause cache invalidation. Currently, CASTAN has successfully analyzed a dozen DPDK-based network functions. In [54], the authors proposed a Proof-of-Concept (PoC) implementation of

a semi-supervised learning algorithm to monitor and detect malfunctioning VNFs. The authors planned to optimize the algorithm and extend their approach to more complex environments and malfunctions for further validation.

C. Deployment

The deployment phase requires careful planning of *service composition* to realize the intended SFCs.

Service composition: Many NFV platforms provide customized services for different traffic classes by parsing the specified service intents, organizing VNFs into logical execution graphs, and configuring the correct traffic routes to steer packets through the corresponding service chains. These platforms commonly employ different mechanisms to reduce the processing redundancy and optimize service deployment. For instance, **Slick** [55] allows developers to specify network services based on traffic classes. Then a Slick “runtime” component parses the service specifications and makes placement decisions using several heuristics before placing the VNFs and configuring the forwarding routes. **SpeedyBox** [56] utilizes a match/action table to consolidate VNF actions at runtime and eliminate redundant processing for SFCs. **NFCompass** [57] adopts a two-level SFC reorganization technique to parallelize VNFs and eliminate redundant processing. It also adopts a task allocation scheme to balance the load and minimize latency. **ParaBox** [58] utilizes a dependency analysis module to identify parallelizable VNFs and implements mirror/merge functions to distribute and aggregate packet copies across the parallelization stages. **NFP** [59] incorporates an orchestrator to analyze VNF dependencies and build optimized service graphs. The NFP infrastructure handles graph execution while dealing with traffic steering, load balancing, and parallel execution. **Metron** [60] decomposes SFC processing graph into stateless and stateful operations. The former is offloaded to in-path programmable switches, while the latter remains on COTS servers. Metron also leverages the in-path tagging to dispatch packets to the correct processing cores. An agent is also deployed on each server to conduct MANO operations. **Flurries** [61] is a container-based NFV platform with flexible service chaining and flow-level service customization. A combination of polling and interrupt I/O scheme is also adopted to consolidate per-flow service chains. **SNF** [62] uses graph composition and set theory for traffic classification, and synthesizes VNFs for each traffic class using a minimal number of elements. **vConductor** [63] automates service deployment with a resource scheduling algorithm to meet business requirements, and uses enhanced inventory management for fault isolation. **CoMb** [64] advocates consolidated development of network functions at execution and management level. It parses service policies and infrastructure descriptions and solves an optimization model to decide the optimal deployment strategy, which is mapped to the distributed data plane by allocating the required resources. **VirtPhy** [65] integrates server-centric topology, SDN techniques, and software switches to realize efficient VNF deployment and service function chaining for edge data centers. **VLH** [66] combines NFV and edge computing to

handle the complex IoT application call-graphs with improved resource efficiency. It also adopts container techniques and the microservices architecture for remote function sharing. **NetFATE** [67] implements a PoC architecture to advocate deploying SFCs on the edge. **fNF** [68] proposes the concept of flyweight network functions that construct slices on the shared IoT infrastructure for applications with diversified QoS requirements. **CoNFV** [69] combines cloud and end-hosts to reduce SFC deployment cost and processing latency.

D. Management and execution

The final phase of the VNF life cycle involves both management and execution of the deployed network services. Some NFV management platforms aim at building full-fledged, holistic MANO systems, while others tackle only a subset of the MANO problems, such as resource scheduling and VNF scaling/migration. We also review platforms that attend to the optimized execution and secure runtime of VNFs and SFCs.

Holistic MANO: Some platforms are purposed for full-fledged, holistic MANO systems. In particular, **ETSO** [70] is an ETSI-compliant NFV MANO platform for heterogeneous cloud environments. It addresses various key service orchestration issues through a shared service abstraction. **UNIFY** [71], [72] employs a layered graph abstraction to automatically map user-specified services into SFCs deployed to the underlying NFVI PoPs. It also models network and service altogether and provides joint optimizations for service management and orchestration. **Open Source MANO (OSM)** [73] aims at implementing a production-grade MANO stack interoperable with third-party NFV components while it allows for efficient service provisioning. **OpenMANO** [74] consists of an orchestrator (openmano), a VIM (openvim), and a graphical user interface. Openvim manages NFVI resources and relies on a REST API to communicate with OpenMANO for MANO operations. **Open Baton** [75] is an extensible MANO framework for service orchestration across heterogeneous NFVIs. It manages a diverse set of VNFs running across NFVI-Nodes with different virtualization technologies and features network slicing for resource multiplexing. **T-NOVA** [76] leverages SDN and cloud management tools to design and implement a software NFV MANO stack for automated VNF management. **TeNOR** [77] is an NFV orchestrator based on a micro-services architecture. It proposes two approaches to address resource and service mapping and provides a marketplace to accommodate third-party VNFs.

Resource scheduling: A large set of NFV platforms specifically tackle the problem of runtime resource scheduling. **NFVnice** [78] adopts rate-cost proportional fairness by adjusting CPU weight for each VNF based on the estimated traffic arrival rate and service time. The scheduling is done by tuning the OS scheduler via Linux cgroups. At runtime, NFVnice monitors workload and employs a back-pressure mechanism to early-drop packets for congested SFCs to spare resources. **EdgeMiner** [79] spares CPU resources from co-located VNFs to execute other applications at the network edge, by employing a back-pressure scheme to detect SFC overloads and puts

upstream VNFs into sleep to harvest the otherwise wasted CPU cycles. **UNiS** [80] is tailored to schedule poll-mode VNFs. For each worker core, it measures intermediate buffer occupancies to make scheduling decisions. The scheduling is non-intrusive as UNiS just tunes parameters of the Linux Realtime Scheduling without rewriting the VNFs. **SNF**¹ [81] dynamically traces the VNF workload and allocates compute resources at a fine granularity. A peer-to-peer in-memory store is deployed to proactively replicate the states and reduce packet processing latency. **ResQ** [82] is a cluster-based resource management framework with guaranteed service layer objectives. It consists of a performance profiler and a scheduler. The profiler performs a set of experiments on the target VNFs to construct profiles. Based on the profiling results, the ResQ scheduler computes a resource-efficient allocation using a greedy approach. ResQ also periodically solves a Mix Integer Linear Programming (MILP) formulation to obtain the optimal allocation, which can be applied to substitute the current allocation if a pre-defined threshold is exceeded. **NetContainer** [83] aims at exploiting cache locality to achieve maximum throughput and low latency for containerized VNFs. The authors first identify the random page allocation policy as the root cause of cache pollution. Then they build an estimation model based on the footprint theory to infer the cache access overhead and model the cache mapping problem as a Minimum Cost/Maximum Flow (MCMF) problem to decide the optimal memory buffer mappings. **NFV-throttle** [84] spreads modules across NFVI to dynamically monitor system conditions and drop excessive packets to prevent VNFs from being overwhelmed. **Iron** [85] introduces an enforcement mechanism to account for the time spent by the VNFs in kernel space, and throttles or even drops packets for the aggressive VNFs through Linux scheduler or a hardware-based approach. **ESFC** [86] is designed for flexible SFC resource scheduling. It implements a controller to monitor the VNF and enforce resource allocation policies using an asynchronous notification mechanism. A hash algorithm is devised to balance packets across VNF replicas while ensuring flow-level affinity. **SCC** [87] collects execution statistics to identify the root causes of SFC delays, which are addressed by SCC runtime by adjusting the allocated batch size, scheduling policies, priorities, and time slices.

Scaling and migration: Some platforms strive for efficient VNF scaling and migration. **Split/Merge** [88] uses a centralized orchestrator and SDN controller to direct instance scaling and flow migration. It provides an API to split or merge flow states among VNF replicas. The system then migrates the relevant states and configures the network to direct flows to the correct replicas. **TFM** [89] performs migration through a centralized controller, which decouples flow and state migration processes with three modules: a state manager, a flow manager, and a forwarding manager. The state manager conducts state migration through southbound APIs. The forwarding manager interacts with the SDN controller to update the corresponding traffic steering rules. The flow manager distributes TFM boxes for packet classification and buffering during VNF migration.

¹The SNF cited here is different from the one previously mentioned [62].

OpenNF [90] implements a controller that consists of an event-driven model to capture relevant packets, a southbound API to request the import/export of VNF states at different granularities, and a northbound API to control applications and instruct state migration, which is carefully crafted to avoid packet losses or out-of-order packets. It also performs state synchronization with strong or eventual consistency. **DiST** [91] and **U-HAUL** [92] follow similar procedures for state and flow migration without controller intervention. In particular, U-HAUL only identifies and migrates states for elephant flows while serving mice flows in original VNFs until expiration, reducing the number of migrated states. **Slim** [93] proposes statelet, a compact packet data representation, to achieve bandwidth-efficient state migration. It also integrates a kernel-bypassing I/O technique to boost performance. **StateAlyzr** [94] is a non-intrusive framework that handles state clone and migration based on program analysis. **LEGO** [95] provides a set of mechanisms for traffic splitting, instance partitioning, and runtime management, to enable elastic scaling of Artificial Neural Network (ANN)-based VNFs. **Lange et al.** [96] employs a machine learning approach to predict and scale the number of VNF instances based on recently monitored traffic. The authors also provided guidelines on the data features and parameters to render reliable predictions. **DeepMigration** [97] deduces the migration and scaling cost of existing VNF instances using a customized graph neural network, and dynamically decides the best flow migration policies through a trained reinforcement learning model. **CHC** [98] adopts a set of state management and optimization techniques to ensure service correctness without degrading performance. In particular, it offloads VNF states to the distributed data store and employs state caching and update algorithms to ensure high performance. It additionally leverages metadata to guarantee a set of correctness properties during traffic redistribution and instance/component failures.

Optimized execution: There are many platforms devoted to optimizing the underlying NFVI to accelerate the execution of VNFs and SFCs. The optimization can be performed directly within individual NFVI nodes (e.g. COTS servers), or by leveraging a hardware-assisted approach that delegates some portion of the VNFs' computational resources to external accelerators. Within the first class, **NetVM** [99] achieves line-rate processing through a shared memory mechanism and relies on a hypervisor switch to steer packets based on traffic or system conditions. It also defines multiple trust domains to limit memory access of untrusted VNFs. **OpenNetVM** [100] follows NetVM design, but adopts containers to wrap VNFs. It achieves more flexible traffic steering by enabling VNFs and management entities to make routing decisions. **ClickOS** [3] utilizes the Click Modular Router [22] to build a wide range of VNFs in Xen-based uni-kernel VMs. A set of optimizations is performed on the hypervisor data path to boost the performance. Similarly, **HyperNF** [101] advocates consolidating VNFs for resource efficiency and reduces synchronization overhead with hypervisor-based packet I/O. **ClimBOS** [102] implements lightweight, isolated, and modular IoT backends based on ClickNF. **MVMP** [103] employs a virtual device

abstraction to flexibly steer traffic between containerized VNFs and physical NICs. **NFF-Go** [104] is designed to build and deploy network functions in the cloud. It leverages Go language for concurrency and safety, and a scheduler to scale VNFs on demand. **IOVtee** [105] optimizes the VNF RX path by mapping the VM queues to hypervisor switch, eliminating the expensive copy operations while ensuring security. **HALO** [106] optimizes the flow classification process by exploiting hardware parallelism of the CPU caches and extending the CPU instruction set to scale flow-rule lookups. **NNF** [107] extends UNIFY's data plane to execute VNFs at end devices and a native controller to instantiate service graphs according to the corresponding VNF templates and employs network namespaces to guarantee isolation and multi-tenancy.

Some platforms adopt the hardware-assisted NFVI optimization. In particular, **P4SC** [108] and **P4NFV** [109], both exploring P4 language to accelerate SFC processing. P4SC parses specified service policies and converts them into a P4 program, which is subsequently deployed onto the P4-compatible hardware. P4NFV is designed for both hardware and software targets and supports runtime reconfiguration without violating state consistency. Albeit augmented with various software acceleration techniques, CPU cores might still fall short of performance. As a result, several platforms explore other hardware components for processing acceleration. **OpenANFV** [110] aims at supporting VNF acceleration in the cloud by delegating a subset of tasks to PCIe-based FPGA card. Similarly, the work in [111] proposes to integrate OpenNetVM with SmartNICs to offload VNF processing and enforce memory isolation. **ClickNP** [112] augments COTS servers with FPGA acceleration and exposes a modular abstraction to implement VNFs. **UNO** [113] targets the SmartNICs (i.e. ASIC, FPGA, System on Chip) for computation offloading without violating the interoperability with the existing orchestration plane. While still relying on a centralized orchestrator to make global decisions, UNO selectively places new VNFs on the underlying SmartNICs to minimize host CPU usage, based on a placement algorithm considering local system status. It also actively reruns the algorithm and adjusts VNF placement between host and SmartNICs. To hide the complexity of SmartNICs from the remote orchestrator, UNO exposes a single-switch abstraction that correctly maps traffic steering rules to the host or SmartNIC switches. **NICA** [114] exploits F-NICs to accelerate inline processing. It implements an API to grant direct control over F-NIC accelerators and an I/O path virtualization for multiple VMs to share F-NICs with security and fairness. Some platforms construct CPU-GPU pipelines to expedite SFC processing. **NetML** [115] accelerates data transfer to GPU by optimizing the data path. **FlowShader** [116] leverages kernel stack for traffic classification and exposes an API to develop compatible VNFs across CPU and GPU domains. It also employs a scheduling algorithm to balance the workload between GPU and CPU. **GPUNFV** [117] employs flow-level parallelism and runs an SFC to completion in a GPU thread. It exploits GPU for processing and devotes CPU for packet I/O and flow classification. **Gen** [118] features the dynamic scheduling of GPU threads for VNF scaling, and supports runtime SFC modification using CUDA API. **Grus** [119]

reduces the processing latency through coordinated access of the PCI-E bus, fine-grained VNF scheduling, and dynamic batching. **G-NET** [120] manipulates GPU context to allow for spatial GPU sharing across manifold VNF kernels and leverages safe pointers to guarantee GPU memory isolation. A scheduling algorithm is also employed to calculate the per-SFC cost and optimize the GPU resource sharing.

Secure runtime: Another group of platforms has been specifically devoted to developing secure VNFs for execution in untrusted environments. **vEPC-sec** [121] incorporates a variety of traffic encryption, validation, and monitoring schemes to safeguard cloud-based LTE VNFs. **SplitBox** [122] distributes VNF functionalities to multiple cloud VMs to obscure its internals from public cloud. **Embark** [123] allows VNFs to operate on encrypted data leveraging a special HTTPS encryption scheme. **BSec-NFVO** [124] introduces a blockchain-based architecture to protect NFV orchestration by auditing all the operations over the SFCs. Other platforms exploit Intel[®] Software Guard Extensions (SGX) [125] instruction codes to secure VNFs from memory reading attacks. In specific, **S-NFV** [126] concentrates on the protection of VNF states by stashing them into the shielded SGX memory region (*enclave*) to prevent unauthorized access or snooping. **Trust-edClick** [127] and **ShieldBox** [128] extend the Click modular router to secure packet processing within SGX enclave, and rely on SGX remote attestation to verify code correctness. **ShieldBox** additionally integrates DPDK for high-speed packet processing and ring buffers to support SFC deployment. Several platforms further protect VNF states. **SafeLib** [129] offers comprehensive protection, including user traffic, VNF code, policy, and execution states. It also integrates DPDK and libVNF to support TCP functionalities without compromising performance. **LightBox** [130] employs a virtual interface to protect enclave I/O, a state management scheme to cache states for active flows, and a space-efficient algorithm for flow classification. **Safebricks** [131] partitions VNF code to minimize the trusted computing base in enclaves and performs packet exchanges across trust boundaries through shared memory. It also supports deploying an entire SFC inside an enclave and leverages Rust primitives to isolate the VNFs.

E. Integrated NFV platforms

Besides the foregoing NFV platforms that can be categorized into a specific phase of the typical VNF life cycle, there is a large collection of integrated NFV platforms that involve multiple phases for end-to-end service provisioning.

Several industrial projects strive for building integrated NFV platforms. For instance, **CloudBand** [132] is a carrier-grade NFV platform from Nokia. It consists of two components: the CloudBand Management System and the CloudBand Node. The former functions as the NFVO that interfaces with the latter through standard OpenStack APIs. CloudBand node integrates the OpenStack Platform as VIM and other Red Hat virtualization solutions to construct NFVI. CloudBand also implements different abstractions that support network services optimized for distributed cloud infrastructure and VNF lifecycle management. **CloudNFV** [133] is an open-source NFV

platform based on cloud computing and SDN. It employs a data model named “active virtualization” to represent network services and infrastructural resources. Based on the current resource usage and specific service profiles, CloudNFV’s MANO plane deploys VNFs to the most suitable NFVI PoPs and configures the corresponding routes. The MANO plane also inspects resources and traffic conditions in real-time to make orchestration decisions according to pre-defined management policies. **SONATA** [134] implements a service development toolchain for service composition and integrates a service platform and a modular orchestration system to deploy and manage network services. **OPNFV** [135] is a Linux Foundation project which integrates several open-source sub-components for the development of NFV systems. It can provide a large variety of tasks including continuous components integration, function verification, performance benchmarking, and service automation, as well as cycle management, dynamic service provisioning, fault recovery, and vendor-agnostic deployment. **ONAP** [136] is a cloud-native NFV platform that provides a whole set of solutions to compose, deploy, and manage the complete life cycle of network services across the NFVI.

There are also many integrated NFV platform implementations from academia. For instance, **Eden** [137] is purposed for provisioning network functions at end-hosts in a single administrative domain. It is composed of a controller, stages, and enclaves at the end-hosts. The controller provides centralized VNF coordination based on its global network view. Stages reside in the end-host stack to associate application semantics to particular traffic classes. The per-host Eden enclave maintains a set of Match/Action tables to decide the destination VNF for each packet based on its traffic class. In Eden, VNFs are written in F# language and are automatically compiled into executable byte-code to be interpreted inside the enclaves. **OpenBox** [138] allows developers to implement VNF logic through the northbound API of the OpenBox controller, which in turn deploys the logic to the data plane and implements the intended processing sequence through the OpenBox protocol. The OpenBox controller merges the core control logic of multiple VNFs to avoid duplicated processing and spare NFVI resources for other tasks. The OpenBox data plane is extensible with specialized hardware or pure software. **Cloud4NFV** [139] is an ETSI-compliant platform. It provides an SFC model for fine-grained traffic classification and steering and relies on cloud management tools for service orchestration. **MicroNF** [140] builds modularized SFCs based on element dependency analysis and places them with minimal inter-VM data transfer. It also employs two algorithms to achieve load-balanced scaling and introduces an infrastructure to realize high-speed forwarding and fair scheduling. **Flick** [141] brings application-specific semantics into VNF development on multi-core COTS servers. The authors implement a domain-specific language to offer high-level abstractions and common primitives to assist VNF development. The compiler automatically translates the flick programs into parallel task graphs with bounded runtime resource usage. Multiple graphs can execute simultaneously without interference through cooperative scheduling. **E2** [142] exposes a “pipelet” abstraction to express network policies, each of which consists of a subset of input

traffic (or traffic class) and a processing graph. E2 manager merges multiple pipelets into a graph and instructs local agents to place VNFs across servers and interconnect them through a high-speed data plane. E2 also provides hooks to VNFs and data plane to make dynamic adjustments. **SDNFV** [143] combines SDN and NFV to realize a flexible, hierarchical control framework over VNFs. It consists of three hierarchies: SDNFV application, SDN controller, NFV orchestrator, and NF manager. SDNFV application utilizes a graph abstraction to represent the intended network services for different traffic flows. Then it proposes a heuristic algorithm to jointly deploy the VNFs to COTS servers and configure traffic routes across them, through the SDN controller and NFV orchestrator. An instance of NF manager is installed on each COTS server to manage the local VNFs and traffic routing. Each manager maintains an extended OpenFlow (OF) table based on host-level status. This table can also be configured by the remote SDN controller (for default routing) and the local VNFs (based on their internal states), realizing a more flexible control paradigm beyond SDN. **GNF** [144] exposes an interface to specify services at the network edge and relies on a manager for MANO operations. The manager instructs per-device agents to deploy and manage VNFs in containers. **DeepNFV** [145] is based on GNF. It incorporates deep learning techniques to learn hidden data patterns and provide enhanced services such as traffic classification, QoS optimization, and link status analysis. Additionally, the NFV platform can provide the tools to automatically detect redundant code and parallelize the jobs that could be performed in parallel.

IV. DESIGN SPACE

We now explore the design space and summarize the different design choices adopted by existing NFV platforms. This section focuses on the technological solution adopted by each platform, and it is complementary to Sec. III, whose taxonomy refers to the platform life cycle of VNFs. We begin our discussion from the MANO plane followed by the service plane and NFVI. The design choices of some existing representative NFV platforms are listed in Table I. For a more detailed description of the NFV design space, please refer to our technical report [146]. Note that in general there is no superior choice over the others, and a choice should be made according to specific use scenarios and application contexts.

A. MANO plane

High-level API: Most of the existing NFV frameworks provide high-level APIs to specify service policies or smooth the process of VNF development. These APIs can be either **Domain-Specific Language (DSL)** or **General-Purpose Language (GPL)**. GPLs such as C, C++, Java, and Python are mature programming languages capable of solving problems in multiple domains. They are shipped with multitudinous control primitives, miscellaneous data structures, and flexible operating patterns. Most of the existing NFV platforms adopt GPL. For example, OpenNF relies on a C++ API to develop control applications. NFVNice exposes the “libnf” C library to perform I/O operations asynchronously and to monitor

the workload of each VNF. OpenBox exposes a Java API for operators to specify processing logic and subscribe to system events. Slick API allows developers to specify service policies in Python, while NetBricks achieves it with a Rust API. Compared to GPLs, DSLs provide higher-level optimized abstractions for specific problems, and they usually operate in an environment with limited operation patterns and restricted resource usage. For example, Flick language supports parallel execution and safe resource sharing. In addition to basic primitives such as event handling and common data types, Flick can deserialize input packets into application-specific data types and vice versa, bringing application semantics into VNF development. Service policies in Eden are specified in F# language for safety checking. NFMorph proposes a DSL that allows developers to express per-packet operations and compiler hints for dependency analysis and runtime optimization.

Placement: Service placement is achieved in two steps: **pre-processing** and **deployment**. In the pre-processing phase, input policies are optimized through graph merging and parallelization. In the deployment phase, network services are installed across NFVI-Nodes with pre-defined objectives. Existing platforms generally follow the same procedure. For instance, CoMb consolidates SFCs on a single NFVI-Node by solving an optimization model based on service and infrastructural description. OpenBox merges input processing graphs with correctness guarantees and deploys the related VNFs to the specified NFVI-Nodes. Slick employs an inflation heuristic to consolidate VNFs with minimum cost and uses a placement algorithm to deploy them while configuring traffic steering rules on the network switches. E2 also merges multiple service graphs to reduce processing redundancy. It models VNF placement as a graph partition problem over NFVI-Nodes and employs a heuristic placement algorithm to minimize the inter-server traffic. SDNFV formulates the placement problem as a MILP problem and designs a heuristic algorithm to maximize resource utilization. Metron leverages SNF to optimize the input graph and constructs a synthesized one, which is subsequently split into a stateful subgraph and a stateless subgraph. The stateful graph is deployed on COTS servers selected by the Metron server selection scheme. The stateless graph is offloaded to in-path network elements based on the locations of the stateful graph. MicroNF performs dependency analysis for VNF elements and reconstructs the service graph to reduce redundant processing and improve resource efficiency. It places the modularized SFCs to the COTS servers by solving an integer programming problem to minimize inter-VM overhead. The μ NF orchestrator constructs an optimal forwarding graph by consolidating VNFs performing similar processing, but the authors did not indicate the placement approaches.

State coordination: With the proliferation of stateful VNFs, it is critical to timely coordinate the processing states upon the scaling, migration, and failover of VNFs. However, it is extremely challenging to simultaneously guarantee flow affinity, correct processing, and minimal service interruption. Existing NFV platforms resort to two strategies, **state migration** and **migration avoidance**, respectively. The former employs different approaches to migrate states. For instance, Split/Merge suspends traffic flows for all replicas and transfers

TABLE I: Design choices for a subset of the existing NFV platforms.

Platform	MANO plane					Service plane				NFV infrastructure (NFVI)						
	High-level API		Placement engine	State coordination		Execution model		TCP function	VNF I/O		Packet I/O	VNF interconnect		Virtualization technique		
	GPL	DSL		SM	MA	RTC	Pipe.		Poll.	Intr.		VS	Cus.	VM	Co.	Pr.
OpenBox	✓		✓	✓	✓					Kernel			✓			
E2		✓	✓	✓	✓		✓			DPDK	✓					
SDNFV			✓		✓			✓		DPDK		✓	✓			
Slick	✓		✓		✓		✓			Kernel					✓	
Eden		✓	✓				✓			Kernel		✓			✓	
MicroNF			✓	✓		✓		✓		DPDK	✓		✓	✓		
μNF		✓		✓	✓	✓			✓	DPDK		✓	✓	✓	✓	
Metron	✓		✓	✓	✓					DPDK	✓				✓	
Flurries	✓						✓	✓	✓	DPDK				✓		
MicroBoxes	✓						✓			DPDK				✓		
OpenNF				✓			✓			Kernel						
Split/Merge	✓			✓						Kernel	✓		✓			
ClickNF	✓				✓		✓	✓		DPDK					✓	
Flick		✓		✓		✓	✓		✓	DPDK					✓	
NetStar	✓			✓	✓	✓	✓	✓		DPDK		✓			✓	
StatelessNF	✓			✓			✓	✓		DPDK					✓	
NFMorph		✓				✓	✓	✓		DPDK		✓			✓	
NetVM	✓				✓			✓		DPDK	✓		✓			
OpenNetVM	✓				✓			✓		DPDK	✓			✓	✓	
NetBricks	✓				✓		✓	✓		DPDK	✓				✓	
ClickOS	✓					✓			✓	netmap	✓		✓			
HyperNF										netmap	✓		✓			
IOVTee										DPDK		✓	✓	✓		
CHC				✓				✓		VMA		✓		✓		
NICA	✓							✓	✓	VMA			✓			
Polycube	✓							✓		eBPF			✓			
NFP						✓				DPDK		✓		✓		
ParaBox										DPDK	✓			✓		
NFVNice	✓						✓	✓		DPDK		✓		✓		
libVNF	✓			✓	✓	✓	✓	✓	✓	DPDK netmap kernel	✓		✓		✓	

the relevant states across them while configuring the related traffic routes. Metron divides states of the overloaded SFC into two groups and copies one group to new replicas. However, both approaches incur in-transit packet losses that might lead to state inconsistency. OpenNF uses a centralized controller and in-path OpenFlow switches to preserve flow affinity and packet processing order without in-transit losses. MicroNF, UNO, and OpenBox also advocate this solution for state coordination. Similarly, TFM deploys a “box” at each VNF instance to buffer incoming packets and feed them in the correct order to the new replica. In contrast, some platforms adopt a migration avoidance strategy to avoid state migration overhead. In particular, E2 splits the flow space and steers part of the incoming flows to the new instance while keeps serving existing flows till termination. Another migration avoidance strategy is state externalization. For example, StatelessNF, CHC, NetStar, and libVNF keep VNF processing states in external data stores to avoid state migration costs.

B. Service plane

NFV platforms are required to consider several critical design choices in the service plane.

Execution model: In NFV domain, two VNF execution models are adopted: **run-to-completion (RTC)** and **pipeline**. In the RTC model, all the elements of a VNF run on a single thread, whereas in the pipeline model, each element

is pinned to a separate thread, as illustrated in Fig. 4a. The performance of either model is highly dependent on processing complexity and input workload, which leads to different levels of cache and memory access patterns. In general, the RTC model presents better performance executing simple VNFs or short SFCs by eliminating inter-core transfer overhead [60]. It also requires fewer cores than the pipeline model. However, the pipeline model enables finer granularity scaling and incurs fewer cache misses processing complex VNFs. Some platforms employ the RTC model to accommodate lightweight VNFs or trimmed SFCs. For instance, CoMb, NetVM, NetBricks, ClickNF, ClickOS, NetStar, and SafeBricks execute VNFs in the RTC model to avoid the inter-core transfer and synchronization overhead; Metron offloads part of its SFCs to the in-path hardware devices, executing the trimmed tasks in RTC model on COTS servers. Other platforms employ the pipeline model. In particular, μNF and MicroNF decompose VNFs or SFCs into loosely-coupled elements to be scaled individually.

TCP functionality: As stateful VNFs have become an important building block in the NFV ecosystem, it is worth pointing out existing platforms that implement or integrate TCP/IP stack to support stateful VNFs at layer 4 or beyond. ClickNF is equipped with a full-fledge modular TCP stack to facilitate the end-host application development. Microboxes comes with a modular, customizable TCP stack that can be shared among a group of VNFs to eliminate redundant pro-

cessing. OpenANFV also designs a TCP stack in the userspace. NICA even implements a simplified TCP stack in SmartNICs to enrich its in-path processing features. xOMB stack only implements simple functions such as TCP connection termination. Instead of developing TCP functionalities from scratch, some platforms choose to directly incorporate third-party solutions. For example, Flick integrates the high-speed kernel-bypassing mTCP stack [147] to realize transport layer VNFs, NetStar directly employs a third-party user-space TCP stack with future/promise abstraction. libVNF is designed to be generic by integrating both the standard networking stack and mTCP. Besides, all the NFV platforms using the kernel TCP/IP stack and POSIX sockets are granted TCP functionalities by default. In particular, Polycube directly cooperates with the kernel TCP/IP stack to build complex SFCs.

VNF I/O: There are also two alternative means for VNFs to perform packet I/O, namely **polling mode** and **interrupt mode**. VNFs running in polling mode keep querying the NICs or upstream VNFs for data, which normally renders better performance at the cost of wasted CPU cycles and increased energy consumption due to idle waiting. Interrupt-based I/O usually does not entail wasted resources but suffers from performance losses due to interrupt propagation delay and cache line warm-up. Existing NFV platforms such as UNO, CHC, NetBricks, ClickNF, NetStar, and StatelessNF, execute VNFs in the polling mode to enhance performance. Other platforms such as Flick, NFNice, xOMB, ClickOS, Flurries, and libVNF execute VNFs in interrupt mode.

Secure execution: As VNFs are increasingly delegated to untrusted environments (e.g., public cloud or third-party networks), traffic data and VNF internals are exposed to potential cyber-attacks. Existing NFV platforms secure the execution of VNFs with **encryption** and **shield execution**. Platforms adopting the former (e.g., vEPC-sec, Embark) leverage cryptographic schemes to enable VNFs to operate directly on encrypted traffic. Platforms adopting shield execution run VNFs in memory regions called enclaves whose contents are strictly protected from external accesses. For example, S-NFV, TrustedClick, ShieldBox, SafeLib, SafeBricks, and LightBox leverage Intel SGX to provide a shield execution environment for VNFs. Similarly, NetVM and OpenNetVM place VNFs inside trusted domains to ensure security. Compared to shield execution, encryption approaches usually incur higher overhead imposed by the complex cryptographic operations and support a limited set of functionalities.

C. NFV Infrastructure (NFVI)

Packet I/O techniques: Existing NFV platforms adopt different I/O techniques to exchange packets with the outside network through physical NICs. When such NICs are managed by COTS servers, the two approaches used for I/O are **kernel-based** and **kernel-bypassing**, as shown in Fig. 4b. Traditional network applications rely on the feature-rich kernel stack for packet I/O, although the overhead imposed by kernel stack makes software solutions fail to sustain line-rate processing [148]. This bottleneck can be overcome by adopting kernel-bypassing techniques (e.g., DPDK [149], netmap [150]).

Netmap partially bypasses the kernel, and it adopts system call based validation and interrupt-based packet reception. DPDK employs complete kernel-bypassing and poll-mode drivers to boost performance. They also expose APIs to simplify VNF development. As shown in Tab. I, most of platforms such as E2, Flick, ClickNF, IOVTee, NetStar, μ NF, Flurries, StatelessNF, NetVM, and OpenNetVM leverage DPDK for packet I/O. netmap is used by ClickOS and HyperNF. NICA and CHC adopt Mellanox Message Accelerator (VMA) [151], another kernel-bypassing technique with standard socket APIs and user-space library. Note that even though the traditional kernel-based approach fails to render comparable performance as kernel-bypassing techniques, it can still be useful when the VNFs are not I/O intensive or the cost to set up a kernel-bypassing stack is too high. The extended Berkeley Packet Filter (eBPF) [25] adopts an in-kernel virtual machine to run user-space programs that can be used to execute network functions. In conjunction with the XDP enhancements [152], it provides high-performance packet processing capabilities. eBPF is adopted by Polycube for packet I/O. Note that libVNF supports kernel, DPDK, and netmap to achieve generality.

VNF interconnects: Existing NFV platforms concatenate consolidated VNFs by integrating or implementing **software switches**. Software switches are widely used by existing platforms for efficient traffic steering. For instance, E2 augments BESS [153] as data plane, ClickOS and HyperNF extend VALE switch [154], CoMb customizes the Click Modular Router [22]. Metron, MiddleClick, SCC, and SplitBox leverage FastClick [148] to transfer packets between VNFs and the network. SplitMerge, TFM, and MicroNF employ Open vSwitch (OVS) [155] for VM networking. UNO extends OVS-DPDK [156] to steer packets at both host and SmartNIC level. NetBricks adopts both OVS-DPDK and BESS to interconnect VNFs. More details about the performance of these software switches can be found in [157]–[159]. Rather than adopting third-party software switches, some platforms implement customized solutions. For instance, G-NET uses a bespoke software switch to route packets between VNFs and physical NICs, NetVM implements a hypervisor software switch to enable state- and data-dependent forwarding.

Virtualization technique: As the central point of any NFV platform, existing implementations deploy network functions in **Virtual Machines (VMs)**, **Containers**, and **Processes**. As illustrated in Fig. 4c, virtualization is implemented at different layers in the commodity hardware, and therefore present different degrees of isolation and resource requirements. VM is a hardware-level virtualization technique that relies on the Virtual Machine Monitor (VMM) or hypervisor to accommodate VNFs². Hypervisors also manage the VMs for efficient resource sharing. Some platforms adopt different VM hypervisors to host VNFs. For example, NetVM, NICA, OpenANFV, IOVTee, and SDNFV adopt KVM; SplitMerge, HyperNF, and FlowOS adopt Xen. However, VMs commonly impose heavy resource demands, huge memory footprints, and

²Note that there is another kind of hypervisor that operates at OS level (namely, hosted hypervisor) which was excluded from our discussion as rarely used by existing NFV platforms.

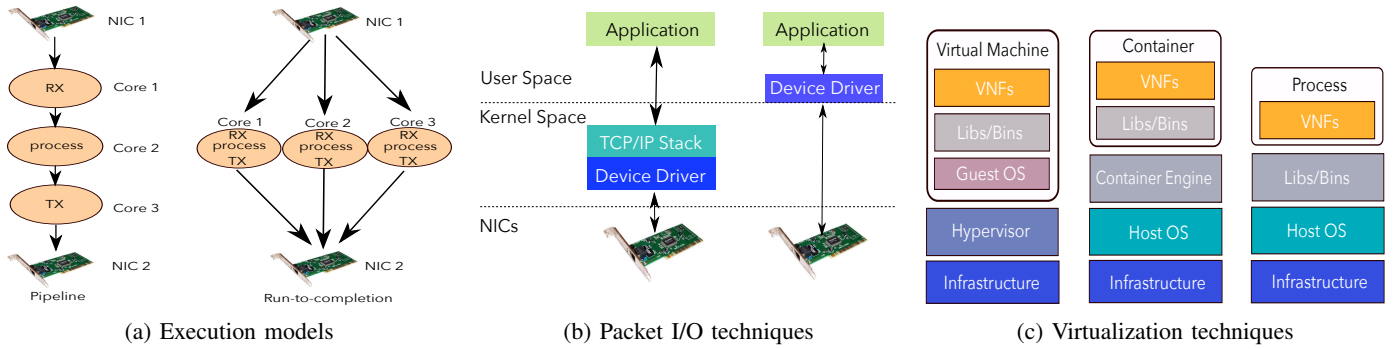

Fig. 4: Illustration of several key design choices

high migration costs. To overcome these deficits, ClickOS and CliMBOS adopt unikernel VMs that are small, agile, and fast-to-boot. The advent of containers, such as LXC and Docker, gives another option. Compared to VMs, containers are OS-level virtualization techniques with a small memory footprint, short boot time, high deployment density, and low migration cost. The disadvantages of containers include weak isolation and degraded security. In terms of performance, they both can sustain line rate processing using tailored I/O paths. At present, many existing NFV platforms opt for containerized VNFs. For instance, OpenNetVM, Flurries, MicroBoxes, NFNice, MVMP, NFP, ParaBox, MVMP, statelessNF, and GNFC employ Docker, while CHC and Iron adopt LXC. Aside from VMs and containers, some platforms deploy VNFs as processes to trade isolation for performance. For example, NetBricks, ClickNF, libVNF, and SafeLib execute VNFs as processes and use different means to guarantee isolation. GPUNFV, Gen, FlowShader, Grus, and G-NET execute VNFs or SFCs as GPU threads. Note that some platforms feature multiple techniques. For example, OpenNetVM and μ NF adopt both process and container. MicroNF runs containers inside VMs probably to improve security.

D. Other design choices

As discussed in [160], there is a large assortment of acceleration techniques for high-speed packet processing. Here, we choose the most commonly utilized techniques and enumerate their adoption by existing NFV platforms. The optimization knobs we consider including zero-copy, batching, memory pre-allocation, parallel execution, CPU cache optimization, and computation offloading. Although these optimizations are commonly applied by high-speed packet processing applications, we discuss them in the context of NFV.

Zero-copy: In the high-speed packet processing domain, runtime memory copy is an expensive operation that usually leads to unbearable overhead. For the sake of performance, many existing NFV platforms deliver packets across VNFs or memory boundaries in a zero-copy manner, by copying only their associated packet descriptors. For example, μ NF implements a zero-copy port abstraction that only exchanges

packet addresses instead of copying full packets between VNFs. NetVM employs a shared memory mechanism to enable zero-copy packet delivery to and between the VNFs running in VMs. Instead of shared memory, IOVTee implements a safe zero-copy mechanism through memory mapping between hypervisor switch and VM. NetBricks adopts Unique Types to implement safe zero-copy packet delivery between NFs. The TCP stack of ClickNF exposes zero-copy interfaces to interact with user-space VNF. NICA leverages ring buffers for zero-copy message exchange between the F-NIC units and the user-space VNFs. GPUNFV achieves zero-copy packet delivery across CPU and GPU boundary through CUDA's page-lock memory. G-NET's switch also employs a zero-copy design.

Batching: In high-speed packet processing frameworks, I/O batching is widely used to amortize the overhead of accessing the physical NIC over multiple packets. This technique is also employed by some NFV platforms to enhance performance. For example, NFNice and EdgeMiner batch the I/O interrupts to amortize VNF wakeup overhead. SCC handles the system calls of VNF I/O in dynamic batches to reduce the overhead of context switches. NFMorph advocates optimizing performance with batch tuning. The VNFs on μ NF platform perform packet I/O in batches through the intermediate ring buffers. The TCP stack of ClickNF exchanges packets with the user-space VNFs in batches. StatelessNF aggregates multiple read/write requests to the data store into a single request to amortize the overhead of remote procedure call (RPC). SafeBricks implements an in-enclave module to perform batched packet I/O between the enclave and the host. LightBox adopts packet batching to amortize the system call overhead. GPUNFV, Grus, FlowShader, G-NET, and Gen deliver packets between CPU and GPU in dynamic batches.

Pre-allocation: Runtime memory allocation remains a heavy task. Barring pre-allocating packet buffers and descriptors for packet I/O with physical NICs, existing NFV platforms usually reserve memory regions to stage and reuse other relevant packet processing data structures. For example, libVNF pre-allocates memory pools for its per-core, persistent request objects, and lock-free packet buffers. Flick pre-allocates its task graphs and queues. S6 pre-allocates a pool of the cooperative, user-space, per-flow micro-threads to avoid the

dynamic thread creation/deletion overhead. NetVM maintains a pool of idle VMs for prompt VNF migration. ShieldBox pre-allocates packet descriptor memory. LightBox pre-allocates state management data structures.

Parallel execution: To take advantage of the multicore CPUs, many platforms explore possibilities for parallelization. μ NF performs a dependency analysis on its forwarding graphs to identify parallelize VNFs. Consecutive VNFs are deemed parallelizable if they perform read-only operations or update disjoint packet regions. Then these VNFs are assigned independent CPU cores to process packets. A reference counter is attached as meta-data to avoid out-of-order operations from downstream VNFs. Likewise, SDNFV allows multiple VNFs to access a packet in parallel using a reference counter embedded in the packet descriptor. Eden exposes a concurrency model that creates consistent state copies for multiple VNFs to execute in parallel in the Eden enclave. CoMb allocates each SFC an independent shim layer to allow for parallel execution of multiple SFCs. Flick instantiates a new task graph for each new connection and schedules the tasks of these graphs onto multiple worker cores in parallel. NetBricks runs per-tenant service processing graphs in parallel in a multi-tenant environment. ClickNF utilizes the Receive-Side Scaling (RSS) of physical NICs to distribute incoming packets to multiple cores with flow-level affinity guaranteed. NetStar builds VNFs with a share-nothing thread model and distributes incoming packets to different threads for parallelized multicore processing. libVNF is built with multicore scalability of VNF and uses per-core data structures to avoid inter-core communication which can hamper the multicore scalability of a VNF.

Cache optimization: Modern CPUs are equipped with hierarchical caches between their cores and the main memory. Cache misses result in extra access to other cache levels or the main memory, which significantly slows down the processing speed. Many existing NFV platforms are aware of this issue and explore opportunities for cache optimization. NetContainer aims at exploiting cache locality at inter-flow and intra-flow levels for NFV workload and leverages page coloring techniques to aggregate buffer pages to separate cache regions to avoid cache contention. ResQ exploits Intel Cache Allocation Technology with corresponding buffer sizing to eliminate last level cache invalidation while ensuring performance isolation. LightBox adapts cache line protection techniques to reduce the cache miss rate. μ NF and NFMorph perform data prefetching in batches to increase the cache hit rate. Some platforms also make their critical internal data structures cache-optimized. For example, the request objects of libVNF are cache-optimized, all the per-core data structures of ClickNF are cache-aligned.

Computation offloading: Computation offloading is widely adopted by existing NFV platforms to alleviate the pressure of COTS servers. Potential resources to offload computing tasks include GPU, smartNICs, and in-path network switches. E2 selectively offloads simple VNFs to adjacent hardware switches. Metron offloads stateless operations to the in-path programmable NICs and switches. OpenBox and Eden also implement their forwarding plane in hardware. OpenNetVM and OpenANFV incorporate programmable NICs or FPGAs for computation offloading. ClickNF explores common NIC

features to perform TCP/IP checksum offloading, TCP segmentation offloading (TSO), and large receive offloading (LRO). GPUNFV, Gen, FlowShader, Grus, and G-NET employ GPU offloading to boost performance. SmartNICs are commonly equipped with programmable, multi-core processors and an integrated operating system, making them ideal to execute computation tasks. UNO exploits smartNICs to offload VNFs, forwarding rules, flow tables, and crypto/compression operations. NICA leverages the inline processing of FPGA on smartNICs to accelerate data plane processing.

V. OPEN ISSUES AND CHALLENGES

In this section, we envision some future directions for NFV platform design, including Artificial Intelligence (AI), network slicing, and Internet of Things (IoT), and discuss the potential challenges therein.

A. AI in NFV

With the proliferation of Artificial Intelligence, an increasing amount of effort has been devoted to driving networks using AI techniques without human intervention. Although Machine Learning (ML) and Deep Learning (DL) techniques have begun to be adopted by some NFV platforms for traffic prediction and runtime management [54], [95], [96], [145], AI is still far away from complete integration into NFV. Since AI techniques such as Neural Networks are intrinsically complex (if not impossible) to comprehend, a huge amount of domain-specific expertise is required to guarantee the correctness and reliability of the AI-integrated NFV solutions. Developers need to master knowledge in both NFV and AI domains to implement production-ready NFV platforms, making it more difficult for newbies to get started and expensive for companies to recruit talents. As the base of ML/DL, large sets of relevant data need to be collected and pre-processed. While plenty of datasets for legacy networks and applications are available, the patterns or features may be at odds with contemporary NFV and 5G networks. It is also time-consuming to extract correct features and train the models, not to mention the tedious verification process to avoid inaccuracy or overfitting. While we believe AI will become commonplace in the NFV domain, it is still in its infancy in the telecommunication industry and several challenges yet need to be overcome to thoroughly unleash the potentials of AI in NFV.

B. Network slicing

As one of the key enabling technologies for 5G, network slicing promises to slice the physical network infrastructure into multiple self-contained, isolated, and programmable logical (or virtual) networks to indulge different genres of services demanded by assorted tenants [161]. Combined with other trending network softwarization technologies such as SDN and cloud/edge computing, NFV platforms are envisaged to realize network slicing over 5G infrastructure. We identify several fundamental challenges that need to be surmounted. Firstly, creating variable-sized network slices for varied tenants or business verticals entails effective management of

an NFV platform's components, including dynamic slice instantiation/termination, cognitive resource scheduling among network slices, adaptive VNF placement and configuration for each slice, efficient intra-/inter-slice communication, and so on. Although some of the management issues have been individually resolved, few platforms come up with a joint solution to manage heterogeneous network slices, each of which calls for a particular set of resource and SLA requirements. As a result, it is of uttermost importance for NFV platforms to manage their services and resources tailored for each slice with guaranteed performance and efficient resource usage. Similarly, each network slice may also come with different levels of security concerns originated from diverse industrial verticals, NFV platforms are thus required to provide means to ensure customized security policies. At a minimum, attacks on one slice must be unconditionally isolated from the others. It is also challenging to enforce security policies for slices spanning across multiple administrative domains. Therefore, NFV platforms are required to implement a brand-new set of mechanisms to eliminate these security concerns.

C. Integration with IoT

In the foreseeable 5G era, the IoT ecosystem is expected to accommodate an unprecedented deluge of data traffic generated by hundreds of billions of heterogeneous interconnected devices. NFV platforms are envisioned to enable massive deployment and flexible management of IoT services [162]. However, most of the platforms reviewed in this paper are not specifically designed for IoT use cases. At present, only a few NFV platforms are tailored for IoT in terms of user privacy [102], QoS [68], deployment [66], and still, a vast design space must be explored in addition to proof-of-concept implementations. In particular, it is unclear whether NFV platforms can handle enormous data traffic with ultra-low latency and high-throughput. While many existing NFV platforms manage to sustain 40/100 Gbps links using high-speed I/O techniques, their performances have not been tested under IoT configurations. The NFV platforms may also face scalability issues due to the immense number of connections from densely distributed IoT devices, making service provisioning and scheduling even more critical. Energy consumption is yet another crucial challenge faced by IoT systems, especially under the progressively heavy and fluctuating traffic load. Albeit a large collection of scientific research has been devoted to energy efficiency, few NFV platforms include this as their design goals. Also, as IoT devices are increasingly deployed in third-party environments, it is equally important to ensure the security of IoT applications. Despite NFV platforms usually leverage data encryption and shield execution to secure VNFs, their applicability in 5G-IoT environments is yet to be comprehensively validated.

VI. CONCLUSION

As a novel paradigm to shift network management and service provisioning, NFV is expected to revolutionize the next-generation telecommunication networks. To accelerate the innovation and commercial adoption of NFV, a large spectrum

of platforms have been implemented in the last eight years. While sharing the ultimate objective of promoting NFV, they usually tackle divergent problems in the NFV eco-system and embrace disparate design choices to achieve different performance metrics or service layer agreements, and few works have been devoted to interpreting this huge collection of platform implementations. In this paper, we concentrate on existing NFV platforms and strive for comprehending their design. After introducing the NFV reference architecture, we present our taxonomy on existing NFV platforms based on their focus on the life cycle of a network function. Then we explore the design space and investigate the various choices individual NFV platforms opt for to tackle different implementation challenges. Last but not least, we envision future research directions for NFV platforms concerning AI, network slicing, and IoT, and discuss the variety of challenges to overcome. We believe that our work presents a first-hand guideline for both network operators and developers to choose or design NFV solutions according to their respective requirements.

VII. ACKNOWLEDGEMENTS

The work has been supported by European Horizon 2020 Programme through the project 5G-EVE on "European 5G validation platform for extensive trials" (grant agreement n. 815074).

REFERENCES

- [1] J. Sherry, S. Hasan, C. Scott, A. Krishnamurthy, S. Ratnasamy, and V. Sekar, "Making middleboxes someone else's problem: network processing as a cloud service," *ACM SIGCOMM CCR*, 2012.
- [2] V. Cisco, "Cisco visual networking index: Forecast and trends, 2017–2022," *White Paper*, 2018.
- [3] J. Martins, M. Ahmed, C. Raiciu, V. Olteanu, M. Honda, R. Bifulco, and F. Huici, "ClickOS and the art of network function virtualization," in *USENIX NSDI*, 2014.
- [4] N. McKeown, T. Anderson, H. Balakrishnan, G. Parulkar, L. Peterson, J. Rexford, S. Shenker, and J. Turner, "OpenFlow: Enabling innovation in campus networks," *ACM SIGCOMM CCR*, 2008.
- [5] R. Mijumbi, J. Serrat, J.-L. Gorricho, N. Bouten, F. De Turck, and R. Boutaba, "Network function virtualization: State-of-the-art and research challenges," *IEEE Communications Surveys & Tutorials*, 2015.
- [6] "The European Telecommunications Standards Institute Industry Specification Group on Network Function Virtualization (ETSI ISG NFV)," <https://www.etsi.org/committee/nfv>, 2019.
- [7] X. Li and C. Qian, "A survey of network function placement," in *IEEE CCNC*, 2016.
- [8] J. G. Herrera and J. F. Botero, "Resource allocation in NFV: A comprehensive survey," *IEEE TNSM*, 2016.
- [9] S. Cherrared, S. Imadali, E. Fabre, G. Gössler, and I. G. B. Yahia, "A survey of fault management in network virtualization environments: Challenges and solutions," *IEEE TNSM*, 2019.
- [10] D. Bhamare, R. Jain, M. Samaka, and A. Erbad, "A survey on service function chaining," *Elsevier JNCA*, 2016.
- [11] W. Yang and C. Fung, "A survey on security in network functions virtualization," in *IEEE NetSoft*, 2016.
- [12] R. Mijumbi, J. Serrat, J.-L. Gorricho, S. Latré, M. Charalambides, and D. Lopez, "Management and orchestration challenges in network functions virtualization," *IEEE Communications Magazine*, 2016.

- [13] N. F. S. de Sousa, D. A. L. Perez, R. V. Rosa, M. A. Santos, and C. E. Rothenberg, "Network service orchestration: A survey," *Computer Communications*, 2019.
- [14] B. Yi, X. Wang, K. Li, M. Huang *et al.*, "A comprehensive survey of network function virtualization," *Computer Networks*, 2018.
- [15] G. ETSI, "Network Functions Virtualisation (NFV): Architectural framework," *ETSI Gs NFV*, 2013.
- [16] P. Bosshart, D. Daly, G. Gibb, M. Izzard, N. McKeown, J. Rexford, C. Schlesinger, D. Talayco, A. Vahdat, G. Varghese *et al.*, "P4: Programming protocol-independent packet processors," *ACM SIGCOMM CCR*, 2014.
- [17] J. W. Anderson, R. Braud, R. Kapoor, G. Porter, and A. Vahdat, "xOMB: Extensible open middleboxes with commodity servers," in *ACM/IEEE ANCS*, 2012.
- [18] A. Panda, S. Han, K. Jang, M. Walls, S. Ratnasamy, and S. Shenker, "NetBricks: Taking the V out of NFV," in *USENIX OSDI*, 2016.
- [19] S. R. Chowdhury, Anthony, H. Bian, T. Bai, and R. Boutaba, " μ NF: A disaggregated packet processing architecture," in *IEEE NetSoft*, 2019.
- [20] G. Liu, Y. Ren, M. Yurchenko, K. Ramakrishnan, and T. Wood, "Microboxes: high performance NFV with customizable, asynchronous TCP stacks and dynamic subscriptions," in *ACM SIGCOMM '18*, 2018.
- [21] M. Gallo and R. Laufer, "ClickNF: A modular stack for custom network functions," in *USENIX ATC '18*, 2018.
- [22] E. Kohler, R. Morris, B. Chen, J. Jannotti, and M. F. Kaashoek, "The Click modular router," *ACM TOCS*, 2000.
- [23] O. Alipourfard and M. Yu, "Decoupling algorithms and optimizations in network functions," in *ACM HotNets*, 2018.
- [24] S. Miano, M. Bertrone, F. Risso, M. V. Bernal, Y. Lu, J. Pi, and A. Shaikh, "A service-agnostic software framework for fast and efficient in-kernel network services," in *ACM/IEEE ANCS*, 2019.
- [25] "eBPF - extended Berkeley Packet Filter," <https://prototype-kernel.readthedocs.io/en/latest/bpf/>, 2020.
- [26] M. Bezahaf, A. Alim, and L. Mathy, "FlowOS: A flow-based platform for middleboxes," in *ACM HotMiddlebox '13*, 2013.
- [27] R. Riggio, I. G. B. Yahia, S. Latré, and T. Rasheed, "Scylla: A language for virtual network functions orchestration in enterprise WLANs," in *IEEE/IFIP NOMS*, 2016.
- [28] T. Barbette, C. Soldani, R. Gaillard, and L. Mathy, "Building a chain of high-speed VNFs in no time," in *IEEE HPSR*, 2018.
- [29] P. Naik, A. Kanase, T. Patel, and M. Vutukuru, "libVNF: Building virtual network functions made easy," in *ACM SOCC*, 2018.
- [30] M. Kablan, A. Alsudais, E. Keller, and F. Le, "Stateless network functions: Breaking the tight coupling of state and processing," in *USENIX NSDI*, 2017.
- [31] S. Woo, J. Sherry, S. Han, S. Moon, S. Ratnasamy, and S. Shenker, "Elastic scaling of stateful network functions," in *USENIX NSDI*, 2018.
- [32] J. Duan, X. Yi, S. Zhao, C. Wu, H. Cui, and F. Le, "NFVactor: A resilient NFV system using the distributed actor model," *IEEE JSAC*, 2019.
- [33] J. Duan, X. Yi, J. Wang, C. Wu, and F. Le, "NetStar: A future/promise framework for asynchronous network functions," *IEEE JSAC*, 2019.
- [34] B. Tschaen, Y. Zhang, T. Benson, S. Banerjee, J. Lee, and J.-M. Kang, "SFC-Checker: Checking the correct forwarding behavior of service function chaining," in *IEEE NFV-SDN*, 2016.
- [35] S. K. Fayaz, T. Yu, Y. Tobioka, S. Chaki, and V. Sekar, "{BUZZ}: Testing context-dependent policies in stateful networks," in *USENIX NSDI*, 2016.
- [36] M. Flittner, J. M. Scheuermann, and R. Bauer, "Chainguard: Controller-independent verification of service function chaining in cloud computing," in *IEEE NFV-SDN*, 2017.
- [37] W. Wu, Y. Zhang, and S. Banerjee, "Automatic synthesis of nf models by program analysis," in *ACM HotNets*, 2016.
- [38] F. Moradi, C. Flinta, A. Johnsson, and C. Meirosu, "Conmon: An automated container based network performance monitoring system," in *IFIP/IEEE IM*, 2017.
- [39] S. Geissler, S. Lange, F. Wamser, T. Zinner, and T. Hoßfeld, "KOMon - Kernel-based online monitoring of VNF packet processing times," in *IEEE NetSys*, 2019.
- [40] P. Naik, D. K. Shaw, and M. Vutukuru, "NFVPerf: Online performance monitoring and bottleneck detection for NFV," in *IEEE NFV-SDN*, 2016.
- [41] R. V. Rosa, C. E. Rothenberg, and R. Szabo, "VBaaS: VNF benchmark-as-a-service," in *IEEE EWSDN '15*, 2015.
- [42] "Barometer Home, OPNFV wiki," <https://wiki.opnfv.org/display/fastpath/Barometer+Home>.
- [43] M. Dodare, Y. Taguchi, R. Kawashima, H. Nakayama, T. Hayashi, and H. Matsuo, "NFV-VIPP: Catching internal figures of packet processing for accelerating development and operations of NFV-nodes," in *IFIP CNSM*, 2019.
- [44] L. Cao, P. Sharma, S. Fahmy, and V. Saxena, "NFV-VITAL: A framework for characterizing the performance of virtual network functions," in *IEEE NFV-SDN*, 2015.
- [45] R. V. Rosa, C. Bertoldo, and C. E. Rothenberg, "Take your VNF to the gym: A testing framework for automated NFV performance benchmarking," *IEEE Communications Magazine*, 2017.
- [46] Q. Du, Z. Ni, R. Zhu, M. Xu, K. Guo, W. You, R. Huang, K. Yin, and Q. Zheng, "A service-based testing framework for NFV platform performance evaluation," in *IEEE ICRMS*, 2018.
- [47] F. Rath, J. Krude, J. Rütth, D. Schemmel, O. Hohlfeld, J. Á. Bitsch, and K. Wehrle, "Symperf: Predicting network function performance," in *ACM SIGCOMM Posters and Demos*, 2017.
- [48] W. Wu, K. He, and A. Akella, "Perfsight: Performance diagnosis for software dataplanes," in *ACM IMC*, 2015.
- [49] I. J. Sanz, D. M. F. Mattos, and O. C. M. B. Duarte, "SFCPerf: An automatic performance evaluation framework for service function chaining," in *IEEE/IFIP NOMS*, 2018.
- [50] D. Cotroneo, L. De Simone, and R. Natella, "NFV-Bench: A dependability benchmark for network function virtualization systems," *IEEE TNSM*, 2017.
- [51] R. Iyer, L. Pedrosa, A. Zaostrovnykh, S. Pirelli, K. Argyraki, and G. Candea, "Performance contracts for software network functions," in *USENIX NSDI*, 2019.
- [52] J. Gong, Y. Li, B. Anwer, A. Shaikh, and M. Yu, "DeepDiag: Detailed nfv performance diagnosis," in *ACM SIGCOMM 2019 Conference Posters and Demos*, 2019.
- [53] L. Pedrosa, R. Iyer, A. Zaostrovnykh, J. Fietz, and K. Argyraki, "Automated synthesis of adversarial workloads for network functions," in *ACM SIGCOMM '18*, 2018.
- [54] J. Ahrens, M. Strufe, L. Ahrens, and H. D. Schotten, "An AI-driven malfunction detection concept for NFV instances in 5G," *arXiv preprint arXiv:1804.05796*, 2018.
- [55] B. Anwer, T. Benson, N. Feamster, and D. Levin, "Programming slick network functions," in *ACM SOSR '15*, 2015.
- [56] Y. Jiang, Y. Cui, W. Wu, Z. Xu, J. Gu, K. Ramakrishnan, Y. He, and X. Qian, "SpeedyBox: Low-latency NFV service chains with cross-NFV runtime consolidation," in *IEEE ICDCS*, 2019.
- [57] Y. Hu and T. Li, "Enabling efficient network service function chain deployment on heterogeneous server platform," in *IEEE HPCA*, 2018.
- [58] Y. Zhang, B. Anwer, V. Gopalakrishnan, B. Han, J. Reich, A. Shaikh, and Z.-L. Zhang, "Parabox: Exploiting parallelism for virtual network functions in service chaining," in *ACM SOSR*, 2017.
- [59] C. Sun, J. Bi, Z. Zheng, H. Yu, and H. Hu, "NFP: Enabling network function parallelism in NFV," in *ACM SIGCOMM '17*, 2017.
- [60] G. P. Katsikas, T. Barbette, D. Kostic, R. Steinert, and G. Q. Maguire Jr, "Metron: NFV Service Chains at the true speed of the underlying hardware," in *USENIX NSDI*, 2018.

- [61] W. Zhang, J. Hwang, S. Rajagopalan, K. Ramakrishnan, and T. Wood, "Flurries: Countless fine-grained NFs for flexible per-flow customization," in *ACM CoNEXT*, 2016.
- [62] G. P. Katsikas, M. Enguehard, M. Kuźniar, G. Q. Maguire Jr, and D. Kostić, "SNF: Synthesizing high performance NFV service chains," *PeerJ Computer Science*, 2016.
- [63] W. Shen, M. Yoshida, K. Minato, and W. Imajuku, "vConductor: An enabler for achieving virtual network integration as a service," *IEEE Communications Magazine*, 2015.
- [64] V. Sekar, N. Egi, S. Ratnasamy, M. K. Reiter, and G. Shi, "Design and implementation of a consolidated middlebox architecture," in *USENIX NSDI*, 2012.
- [65] C. K. Dominicini, G. L. Vassoler, L. F. Meneses, R. S. Villaca, M. R. Ribeiro, and M. Martinello, "VirtPhy: Fully programmable NFV orchestration architecture for edge data centers," *IEEE TNSM*, 2017.
- [66] Y.-Y. Shih, H.-P. Lin, A.-C. Pang, C.-C. Chuang, and C.-T. Chou, "An NFV-based service framework for IoT applications in edge computing environments," *IEEE TNSM*, 2019.
- [67] A. Lombardo, A. Manzalini, G. Schembra, G. Faraci, C. Rametta, and V. Riccobene, "An open framework to enable NetFATE (Network Functions at the edge)," in *IEEE NetSoft*, 2015.
- [68] C. A. Ouedraogo, S. Medjah, C. Chassot, and J. Aguilar, "Flyweight network functions for network slicing in IoT," in *IEEE SaCoNet*, 2018.
- [69] Z. Xu, Y. Cui, and Y. Jiang, "CoNFV: An endhost-cloud collaborated network function virtualization framework," in *IEEE IMCEC*, 2018.
- [70] M. Mechtri, C. Ghribi, O. Soualah, and D. Zeghlache, "NFV orchestration framework addressing SFC challenges," *IEEE Communications Magazine*, 2017.
- [71] A. Császár, W. John, M. Kind, C. Meirosu, G. Pongrácz, D. Staessens, A. Takács, and F.-J. Westphal, "Unifying cloud and carrier network: EU FP7 project UNIFY," in *IEEE/ACM UCC*, 2013.
- [72] S. Van Rossem, X. Cai, I. Cerrato, P. Danielsson, F. Németh, B. Pechenot, I. Pelle, F. Risso, S. Sharma, P. Sköldström *et al.*, "NFV service dynamicity with a DevOps approach: Insights from a use-case realization," in *IFIP/IEEE IM*, 2017.
- [73] "Open Source Mano," <https://osm.etsi.org/>, 2020.
- [74] D. Lopez, "OpenMANO: The dataplane ready open source NFV MANO stack," in *IETF Meeting Proceedings, Dallas, Texas, USA*, 2015.
- [75] "OPEN BATON: An extensible and customizable NFV MANO-compliant framework," <https://openbaton.github.io/>, 2019.
- [76] G. Xilouris, M.-A. Kourtis, M. J. McGrath, V. Riccobene, G. Petralia, E. Markakis, E. Palis, A. Georgios, G. Gardikis, J. F. Riera *et al.*, "Tnova: Network functions as-a-service over virtualised infrastructures," in *IEEE NFV-SDN*, 2015.
- [77] J. F. Riera, J. Batallé, J. Bonnet, M. Días, M. McGrath, G. Petralia, F. Liberati, A. Giuseppi, A. Pietrabissa, A. Ceselli *et al.*, "TeNOR: Steps towards an orchestration platform for multi-PoP NFV deployment," in *IEEE NetSoft*, 2016.
- [78] S. G. Kulkarni, W. Zhang, J. Hwang, S. Rajagopalan, K. Ramakrishnan, T. Wood, M. Arumathurai, and X. Fu, "NFVNice: Dynamic backpressure and scheduling for NFV service chains," in *ACM SIGCOMM '17*, 2017.
- [79] L. Zhang, C. Li, P. Wang, Y. Liu, Y. Hu, Q. Chen, and M. Guo, "Characterizing and orchestrating NFV-ready servers for efficient edge data processing," in *ACM IWQoS '19*, 2019.
- [80] S. R. Chowdhury, T. Bai, R. Boutaba, J. François *et al.*, "UNiS: A user-space non-intrusive workflow-aware virtual network function scheduler," in *IEEE CNSM*, 2018.
- [81] A. Singhvi, J. Khalid, A. Akella, and S. Banerjee, "SNF: Serverless network functions," *arXiv preprint arXiv:1910.07700*, 2019.
- [82] A. Tootoonchian, A. Panda, C. Lan, M. Walls, K. Argyraki, S. Ratnasamy, and S. Shenker, "ResQ: Enabling slos in network function virtualization," in *USENIX NSDI*, 2018.
- [83] Y. Hu, M. Song, and T. Li, "Towards full containerization in containerized network function virtualization," *ACM SIGOPS Operating Systems Review*, 2017.
- [84] D. Cotroneo, R. Natella, and S. Rosiello, "NFV-throttle: An overload control framework for network function virtualization," *IEEE TNSM*, 2017.
- [85] J. Khalid, E. Rozner, W. Felter, C. Xu, K. Rajamani, A. Ferreira, and A. Akella, "Iron: Isolating network-based CPU in container environments," in *USENIX NSDI*, 2018.
- [86] Z. Shen and Y. Zhang, "An NFV framework for supporting elastic scaling of service function chain," in *IEEE ICC*, 2018.
- [87] G. P. Katsikas, G. Q. Maguire Jr, and D. Kostić, "Profiling and accelerating commodity NFV service chains with SCC," *Journal of Systems and Software*, 2017.
- [88] S. Rajagopalan, D. Williams, H. Jamjoom, and A. Warfield, "Split/merge: System support for elastic execution in virtual middleboxes," in *USENIX NSDI*, 2013.
- [89] Y. Wang, G. Xie, Z. Li, P. He, and K. Salamatian, "Transparent flow migration for NFV," in *IEEE ICNP*, 2016.
- [90] A. Gember-Jacobson, R. Viswanathan, C. Prakash, R. Grandl, J. Khalid, S. Das, and A. Akella, "OpenNF: Enabling innovation in network function control," in *ACM SIGCOMM CCR*, 2014.
- [91] B. Kothandaraman, M. Du, and P. Sköldström, "Centrally controlled distributed VNF state management," in *ACM HotMiddlebox '15*, 2015.
- [92] L. Liu, H. Xu, Z. Niu, P. Wang, and D. Han, "U-HAUL: Efficient state migration in NFV," in *ACM APSys*, 2016.
- [93] L. Nobach, I. Rimac, V. Hilt, and D. Hausheer, "Statelet-based efficient and seamless NFV state transfer," *IEEE TNSM*, 2017.
- [94] J. Khalid, A. Gember-Jacobson, R. Michael, A. Abhashkumar, and A. Akella, "Paving the way for NFV: Simplifying middlebox modifications using StateAlyzr," in *USENIX NSDI*, 2016.
- [95] M. Zhang, J. Bai, G. Li, Z. Meng, H. Li, H. Hu, and M. Xu, "When NFV meets ANN: Rethinking elastic scaling for ANN-based NFs," in *IEEE ICNP*, 2019.
- [96] S. Lange, H.-G. Kim, S.-Y. Jeong, H. Choi, J.-H. Yoo, and J. W.-K. Hong, "Machine learning-based prediction of VNF deployment decisions in dynamic networks," in *IEEE APNOMS*, 2019.
- [97] P. Sun, J. Lan, J. Li, Z. Guo, Y. Hu, and T. Hu, "Efficient Flow Migration for NFV with Graph-aware Deep Reinforcement Learning," *Computer Networks*, p. 107575, 2020.
- [98] J. Khalid and A. Akella, "Correctness and performance for stateful chained network functions," in *USENIX NSDI*, 2019.
- [99] J. Hwang, K. K. Ramakrishnan, and T. Wood, "NetVM: High performance and flexible networking using virtualization on commodity platforms," *IEEE TNSM*, 2015.
- [100] W. Zhang, G. Liu, W. Zhang, N. Shah, P. Lopreiato, G. Todeschi, K. Ramakrishnan, and T. Wood, "OpenNetVM: A platform for high performance network service chains," in *ACM HotMiddlebox '16*, 2016.
- [101] K. Yasukata, F. Huici, V. Maffione, G. Lettieri, and M. Honda, "HyperNF: Building a high performance, high utilization and fair NFV platform," in *ACM SOCC*, 2017.
- [102] M. Gallo, S. Ghamri-Doudane, and F. Pianese, "ClimBOS: A modular NFV cloud backend for the internet of things," in *IFIP NTMS*, 2018.
- [103] C. Zheng, Q. Lu, J. Li, Q. Liu, and B. Fang, "A flexible and efficient container-based NFV platform for middlebox networking," in *ACM SAC*, 2018.
- [104] "NFF-Go - Network Function Framework for GO (former YANFF)," <https://github.com/intel-go/nff-go>, 2019.
- [105] R. Kawashima and H. Matsuo, "IOVTee: A fast and pragmatic software-based zero-copy/pass-through mechanism for NFV-nodes," in *2018 IEEE Conference on Network Function Virtualization and Software Defined Networks (NFV-SDN)*. IEEE, 2018, pp. 1–6.

- [106] Y. Yuan, Y. Wang, R. Wang, and J. Huang, "HALO: Accelerating flow classification for scalable packet processing in NFV," in *Proceedings of the 46th International Symposium on Computer Architecture*, 2019.
- [107] R. Bonafiglia, S. Miano, S. Nuccio, F. Risso, and A. Sapio, "Enabling NFV services on resource-constrained CPEs," in *IEEE Cloudnet*, 2016.
- [108] X. Chen, D. Zhang, X. Wang, K. Zhu, and H. Zhou, "P4SC: Towards high-performance service function chain implementation on the p4-capable device," in *IFIP/IEEE IM*, 2019.
- [109] M. He, A. Basta, A. Blenk, N. Deric, and W. Kellerer, "P4NFV: An NFV architecture with flexible data plane reconfiguration," in *IEEE CNSM*, 2018.
- [110] X. Ge, Y. Liu, D. H. Du, L. Zhang, H. Guan, J. Chen, Y. Zhao, and X. Hu, "OpenANFV: Accelerating network function virtualization with a consolidated framework in openstack," in *ACM SIGCOMM CCR*, 2014.
- [111] Z. Ni, G. Liu, D. Afanasev, T. Wood, and J. Hwang, "Advancing network function virtualization platforms with programmable NICs," in *IEEE LANMAN*, 2019.
- [112] B. Li, K. Tan, L. Luo, Y. Peng, R. Luo, N. Xu, Y. Xiong, P. Cheng, and E. Chen, "ClickNP: Highly flexible and high performance network processing with reconfigurable hardware," in *Proceedings of the 2016 ACM SIGCOMM Conference*, 2016, pp. 1–14.
- [113] Y. Le, H. Chang, S. Mukherjee, L. Wang, A. Akella, M. M. Swift, and T. Lakshman, "UNO: Unifying host and smart NIC offload for flexible packet processing," in *ACM SoCC '17*, 2017.
- [114] H. Eran, L. Zeno, M. Tork, G. Malka, and M. Silberstein, "NICA: An infrastructure for inline acceleration of network applications," in *USENIX ATC*, 2019.
- [115] A. Dhakal and K. Ramakrishnan, "NetML: An NFV platform with efficient support for machine learning applications," in *IEEE NetSoft*, 2019.
- [116] X. Yi, J. Wang, J. Duan, W. Bai, C. Wu, Y. Xiong, and D. Han, "FlowShader: A generalized framework for GPU-accelerated VNF flow processing," in *IEEE ICNP*, 2019.
- [117] X. Yi, J. Duan, and C. Wu, "GPUNFV: a GPU-accelerated NFV system," in *ACM APNet '17*, 2017.
- [118] Z. Zheng, J. Bi, C. Sun, H. Yu, H. Hu, Z. Meng, S. Wang, K. Gao, and J. Wu, "Gen: A GPU-accelerated elastic framework for NFV," in *ACM APNet '18*, 2018.
- [119] Z. Zheng, J. Bi, H. Wang, C. Sun, H. Yu, H. Hu, K. Gao, and J. Wu, "Grus: Enabling latency SLOs for GPU-accelerated NFV systems," in *IEEE ICNP*, 2018.
- [120] K. Zhang, B. He, J. Hu, Z. Wang, B. Hua, J. Meng, and L. Yang, "G-NET: Effective GPU sharing in NFV systems," in *USENIX NSDI*, 2018.
- [121] M. T. Raza, S. Lu, and M. Gerla, "vEPC-sec: Securing LTE network functions virtualization on public cloud," *IEEE Transactions on Information Forensics and Security*, 2019.
- [122] H. J. Asghar, L. Melis, C. Soldani, E. De Cristofaro, M. A. Kaafar, and L. Mathy, "Splitbox: Toward efficient private network function virtualization," in *ACM HotMiddlebox '16*, 2016.
- [123] C. Lan, J. Sherry, R. A. Popa, S. Ratnasamy, and Z. Liu, "Embark: Securely outsourcing middleboxes to the cloud," in *USENIX NSDI*, 2016.
- [124] G. A. F. Rebello, I. D. Alvarenga, I. J. Sanz, and O. C. M. Duarte, "BSec-NFVO: A blockchain-based security for network function virtualization orchestration," in *IEEE ICC*, 2019.
- [125] F. McKeen, I. Alexandrovich, A. Berenzon, C. V. Rozas, H. Shafi, V. Shanbhogue, and U. R. Savagaonkar, "Innovative instructions and software model for isolated execution." *Hasp@ isca*, 2013.
- [126] M.-W. Shih, M. Kumar, T. Kim, and A. Gavrilovska, "S-NFV: Securing NFV states by using SGX," in *ACM SDN-NFV Security '16*, 2016.
- [127] M. Coughlin, E. Keller, and E. Wustrow, "Trusted click: Overcoming security issues of NFV in the cloud," in *ACM SDN-NFV Sec '17*, 2017.
- [128] B. Trach, A. Krohmer, F. Gregor, S. Arnautov, P. Bhatotia, and C. Fetzer, "ShieldBox: Secure middleboxes using shielded execution," in *ACM SOSR*, 2018.
- [129] E. Marku, G. Biczók, and C. Boyd, "Towards protected VNFs for multi-operator service delivery," in *IEEE NetSoft*, 2019.
- [130] H. Duan, C. Wang, X. Yuan, Y. Zhou, Q. Wang, and K. Ren, "LightBox: Full-stack protected stateful middlebox at lightning speed," in *ACM SIGSAC CCS*, 2019.
- [131] R. Poddar, C. Lan, R. A. Popa, and S. Ratnasamy, "Safebricks: Shielding network functions in the cloud," in *USENIX NSDI*, 2018.
- [132] "CloudBand: Adopt lean operations and increase business agility," <https://www.nokia.com/networks/solutions/cloudband/>, 2019.
- [133] "CloudNFV," <https://www.cloudnfv.com/>, 2020.
- [134] "SONATA NFV: Home," <http://sonatanfv.org/>, 2020.
- [135] C. Price, S. Rivera *et al.*, "OPNFV: An open platform to accelerate NFV," *White Paper: A Linux Foundation Collaborative Project*, 2012.
- [136] "ONAP - Home," <https://www.onap.org/>, 2020.
- [137] H. Ballani, P. Costa, C. Gkantsidis, M. P. Grosvenor, T. Karagiannis, L. Koromilas, and G. O'Shea, "Enabling end-host network functions," in *ACM SIGCOMM CCR*, 2015.
- [138] A. Bremner-Barr, Y. Harchol, and D. Hay, "OpenBox: a software-defined framework for developing, deploying, and managing network functions," in *ACM SIGCOMM*, 2016.
- [139] J. Soares, C. Gonçalves, B. Parreira, P. Tavares, J. Carapinha, J. P. Barraca, R. L. Aguiar, and S. Sargento, "Toward a telco cloud environment for service functions," *IEEE Communications Magazine*, 2015.
- [140] Z. Meng, J. Bi, H. Wang, C. Sun, and H. Hu, "MicroNF: An efficient framework for enabling modularized service chains in NFV," *IEEE JSAC*, 2019.
- [141] A. Alim, R. G. Clegg, L. Mai, L. Rupprecht, E. Seckler, P. Costa, P. Pietzuch, A. L. Wolf, N. Sultana, J. Crowcroft *et al.*, "FLICK: Developing and running application-specific network services," in *USENIX ATC*, 2016.
- [142] S. Palkar, C. Lan, S. Han, K. Jang, A. Panda, S. Ratnasamy, L. Rizzo, and S. Shenker, "E2: A framework for NFV applications," in *ACM SOSP '15*, 2015.
- [143] W. Zhang, G. Liu, A. Mohammadkhan, J. Hwang, K. Ramakrishnan, and T. Wood, "SDNFV: Flexible and dynamic software defined control of an application-and flow-aware data plane," in *ACM Middleware Industry '16*, 2016.
- [144] R. Cziva and D. P. Pezaros, "Container network functions: Bringing NFV to the network edge," *IEEE Communications Magazine*, 2017.
- [145] L. Li, K. Ota, and M. Dong, "DeepNFV: A lightweight framework for intelligent edge network functions virtualization," *IEEE Network*, 2018.
- [146] T. Zhang, "NFV platform design: A survey." *arXiv: Networking and Internet Architecture*, 2020.
- [147] E. Jeong, S. Wood, M. Jamshed, H. Jeong, S. Ihm, D. Han, and K. Park, "mTCP: A highly scalable user-level TCP stack for multicore systems," in *USENIX NSDI*, 2014.
- [148] T. Barbette, C. Soldani, and L. Mathy, "Fast userspace packet processing," in *ACM/IEEE ANCS*, 2015.
- [149] "Data Plane Development Kit," <https://www.dpdk.org/>, 2020.
- [150] L. Rizzo, "Netmap: A novel framework for fast packet I/O," in *USENIX Security 12*, 2012.
- [151] "Linux user space library for network socket acceleration based on RDMA compatible network adaptors," <https://github.com/Mellanox/libvma>, 2019.
- [152] T. Høiland-Jørgensen, J. D. Brouer, D. Borkmann, J. Fastabend, T. Herbert, D. Ahern, and D. Miller, "The express data path: Fast

programmable packet processing in the operating system kernel,” in *ACM CoNEXT’18*, 2018, pp. 54–66.

- [153] S. Han, K. Jang, A. Panda, S. Palkar, D. Han, and S. Ratnasamy, “SoftNIC: A software NIC to augment hardware,” *Tech. Rep. UCB/EECS-2015-155*, 2015.
- [154] L. Rizzo and G. Lettieri, “VALE, a switched ethernet for virtual machines,” in *ACM CoNEXT*, 2012.
- [155] B. Pfaff, J. Pettit, T. Koponen, E. Jackson, A. Zhou, J. Rajahalme, J. Gross, A. Wang, J. Stringer, P. Shelar *et al.*, “The design and implementation of Open vSwitch,” in *USENIX NSDI*, 2015.
- [156] “Open vSwitch with DPDK,” <http://docs.openvswitch.org/en/latest/intro/install/dpdk/>, 2020.
- [157] T. Zhang, L. Linguaglossa, J. Roberts, L. Iannone, M. Gallo, and P. Giaccone, “A benchmarking methodology for evaluating software switch performance for NFV,” in *IEEE NetSoft*, 2019.
- [158] T. Zhang, L. Linguaglossa, M. Gallo, P. Giaccone, L. Iannone, and J. Roberts, “Comparing the performance of state-of-the-art software switches for NFV,” in *ACM CoNEXT*, 2019.
- [159] R. Kawashima, H. Nakayama, T. Hayashi, and H. Matsuo, “Evaluation of forwarding efficiency in NFV-nodes toward predictable service chain performance,” *IEEE TNSM*, 2017.
- [160] L. Linguaglossa, S. Lange, S. Pontarelli, G. Rétvári, D. Rossi, T. Zinner, R. Bifulco, M. Jarschel, and G. Bianchi, “Survey of performance acceleration techniques for network function virtualization,” *Proceedings of the IEEE*, 2019.
- [161] A. A. Barakabitze, A. Ahmad, R. Mijumbi, and A. Hines, “5G network slicing using SDN and NFV: A survey of taxonomy, architectures and future challenges,” *Computer Networks*, vol. 167, p. 106984, 2020.
- [162] G. A. Akpakwu, B. J. Silva, G. P. Hancke, and A. M. Abu-Mahfouz, “A survey on 5G networks for the Internet of Things: Communication technologies and challenges,” *IEEE Access*, 2017.



Tianzhu Zhang is a research engineer at Nokia Bell Labs. He received his B.S. degree from Huazhong University of Science and Technology, Wuhan, China, in 2012. Afterward, he received the M.S. degree in 2014, and the Ph.D. degree in 2017, both from Politecnico di Torino, Turin, Italy. From 2017 to 2019, he was a PostDoc researcher at Telecom ParisTech and LINCS, under a research grant from Cisco Systems. He joined Nokia Bell Labs in August 2020. His current research interests include SDN/NFV, Artificial Intelligence, Edge Computing,

Robotics, Big Data, and log analysis.



Han Qiu (Member, IEEE) received the B.E. degree from the Beijing University of Posts and Telecommunications, Beijing, China, in 2011, the M.S. degree from Telecom-ParisTech (Institute Eurecom), Biot, France, in 2013, and the Ph.D. degree in computer science from the Department of Networks and Computer Science, Telecom-ParisTech, Paris, France, in 2017. He is currently a Research Engineer with Telecom Paris, France. His research interests include AI security, big data security, applied cryptography, and cloud computing.



Leonardo Linguaglossa is an assistant professor at Telecom Paris (France). He received his master degree in telecommunication engineering at University of Catania (Italy) in 2012. He pursued a Ph.D. in Computer Networks in 2016 through a joint doctoral program with Alcatel-Lucent Bell Labs (nowadays Nokia), INRIA and University Paris 7. Leonardo’s research interests focus on architecture, design and prototyping of systems for high-speed software packet processing, future Internet architecture and SDN.



Walter Cerroni (M’01, SM’16) is an Associate Professor of communication networks at the University of Bologna, Italy. His recent research interests include software-defined networking, network function virtualization, service function chaining in cloud computing platforms, intent-based northbound interfaces for multi-domain/multi-technology virtualized infrastructure management, modeling and design of inter- and intra-data center networks. He co-authored more than 130 articles published in the most renowned international journals, magazines and conference proceedings. He serves/served as Series Editor for the IEEE Communications Magazine, Associate Editor for the IEEE Communications Letters, and Technical Program Co-Chair for IEEE-sponsored international workshops and conferences.



Paolo Giaccone (M’99, SM’16) received the Dr.Ing. and Ph.D. degrees in telecommunications engineering from the Politecnico di Torino, Torino, Italy, in 1998 and 2001, respectively. During the summer of 1998, he was with High Speed Networks Research Group, Lucent Technology-Bell Labs, Holmdel, NJ, USA. From 2000 to 2001 and in 2002, he was with Information Systems Networking Lab, Department of Electrical Engineering, Stanford University, Stanford, CA, USA. He is currently an Associate Professor with the Department of Electronics, Politecnico

di Torino. His main area of interest is in the design of network algorithms, in particular for the control of software-defined networks, and cloud computing systems.