

Integrated sensing system for upper limbs in neurologic rehabilitation

Original

Integrated sensing system for upper limbs in neurologic rehabilitation / DE PASQUALE, Giorgio; Ruggeri, Valentina. - In: PROCEDIA STRUCTURAL INTEGRITY. - ISSN 2452-3216. - STAMPA. - 12:(2018), pp. 82-86.
[10.1016/j.prostr.2018.11.104]

Availability:

This version is available at: 11583/2854530 since: 2020-12-02T19:12:58Z

Publisher:

Elsevier

Published

DOI:10.1016/j.prostr.2018.11.104

Terms of use:

This article is made available under terms and conditions as specified in the corresponding bibliographic description in the repository

Publisher copyright

(Article begins on next page)



AIAS 2018 International Conference on Stress Analysis

Integrated sensing system for upper limbs in neurologic rehabilitation

Giorgio De Pasquale*, Valentina Ruggeri

Politecnico di Torino, Dept. of Mechanics and Aerospace, Torino 10129, Italy

Abstract

Wearable sensing devices for monitoring physiological parameters have proved their benefits in reducing the recovery time of mobility and in restoring the neuro-cognitive processes underlying the movement of the body. This is particularly evident in neurological patients from trauma or degenerative diseases. This kind of devices are generally wired sensors fixed on flexible supports, with complicated configuration and calibration. The work presented here has the goal to provide the design and implementation of a training system for rehabilitation including seven types of sensors, dedicated areas for data transmission in wireless mode, power management and signal multiplexing.

© 2018 The Authors. Published by Elsevier B.V.

This is an open access article under the CC BY-NC-ND license (<http://creativecommons.org/licenses/by-nc-nd/3.0/>)

Peer-review under responsibility of the Scientific Committee of AIAS 2018 International Conference on Stress Analysis.

Keywords: wearable sensors; smart fabrics; integrated systems; e-textiles; human monitoring.

1. Introduction

The sense of touch allows humans and animals to perform coordinated and efficient interactions within their environment. Hands, in particular, support a huge number of tasks in our everyday life. Because of this, hand function impairment caused by neurological disorders, such as stroke or cervical spinal cord injury, has high impact on life quality and independence for affected people. Physical training therapy is of high clinical importance to improve motor

* Corresponding author. Tel.: +39.011.0906912; fax: +39.011.0906999.

E-mail address: giorgio.depasquale@polito.it

recovery. Therefore, considerable research efforts have been addressed towards the development of novel therapies for upper limbs functions rehabilitation based on glove systems. Instrumented gloves allow monitoring hand motion during rehabilitative exercises, thanks to which patients reacquire/increase totally or partially their original abilities. This technology has important advantages. Firstly, it allows the simultaneous recording of dynamic finger movements during the performance of skilled tasks, such as grasping objects, pinching, etc. Secondly, it provides the tool for evaluating slight changes in the motor skills of the hand. Finally, instrumented gloves show the possibility to measure patient's abilities during the execution of activities of daily living tasks.

The first system that enhanced applied research with glove devices and spread their popularity worldwide was the commercialization of the Data Glove (Zimmerman 1982) in the United States in 1987. In 1997, Humanglove (Dipietro et al. 2003) was developed to measure the finger joint angles with 20 Hall effect sensors (four sensors for each finger), as well as fingers and thumb abduction/adduction. In the same years, a goniometric glove (the SIGMA glove: Sheffield Instrumented Glove for Manual Assessment) (Williams 1997; Williams et al. 2000) was commercialized. In 2009 we assist to one of the first glove-based systems (Swallow et al. 2009), which is able to provide a feedback to the user. This technology harvests waste mechanical energy and utilizes this energy to suppress hand tremors. In the same year two researchers, Gentner and Classen, developed at the German university of Würzburg the WU glove (Gentner et al. 2009) for hand rehabilitation. It has 14 resistive sensors to measure finger bending and ab/adduction. Successively in 2015 a wearable tactile data-glove (Busher et al. 2015) with 54 tactile cells was made by pressure sensors in order to estimate contact forces. The authors presented smart sensing gloves with embedded sensors and transducers in previous works (De Pasquale et al., 2018; De Pasquale et al. 2016; De Pasquale et al. 2015) and dedicated experimental methodologies to asses reliability of integrated systems (De Pasquale and Mura 2018; De Pasquale 2015; De Pasquale 2016).

In this paper, the investigation on the primary rehabilitation activities in neuro-rehabilitation processes has been conducted in order to identify the physical measurement parameters and the types of sensors. The selected transducers have reduced dimensions, consumption and low weight. The preliminary design activity has produced a prototype PCB for the evaluation of the functionality and compatibility of the electronic components. Different types of sensors and evaluation boards have been analyzed and tested. Once validated, the circuit layout has been miniaturized up to about 30x30mm.

2. Rehabilitation trainings

The clinical specifications of the device, i.e. the exercise that it must monitor, have been selected from the most common rehabilitation activities. This rehabilitation consists in daily exercises of the upper limbs that train simultaneously velocity, precision, force and accuracy. The results of this analysis in terms of quantities to measure and required sensors are reported in Table 1.

Table 1. Typologies of exercises and associated sensors.

Training	Quantity to measure	Sensor
PINCHING	Execution time	Force sensor
	Sequence errors	
GRASPING	Force of the fingers	Force sensors
	Opening angles of the fingers	Bend sensor
WRIST	Wrist rotation	3 axis Accelerometer, 3-axis Gyroscope, Magnetometer
	Wrist flexion	
REACHING	Execution time	Force sensor
FOLLOWING A SPOT ON A SCREEN	Reaction time	Accelerometer
	Execution time	Accelerometer
PHYSIOLOGICAL MEASUREMENTS	Heart Pulsation and Heart Rate	Pulsation sensor
	Temperature	Temperature sensor
	Sweating	Skin conductance sensor

3. System description

The system includes the following sensors:

a) four force sensors FlexiForce A301, based on variable resistance and fabricated by conductive inks deposited on flexible polymer substrate;

- b) four piezo-resistive bend sensors Flexpoint;
- c) galvanic skin response (GSR) sensor used to monitor the emotional status of the patient;
- d) integrated 3D MEMS accelerometer and gyroscope (LSM6DS0 by STMicroelectronics);
- e) pulsometer for monitoring the rate of the patient’s heart, also referred to as skin conductance (SC) or electro-dermal activity (EDA);
- f) temperature sensor (MAX30205 by Maxim Integrated);
- g) 3D magnetometer with I2C serial bus interface for providing spatial positioning of the hand in combination with the accelerometer and gyroscope’s outputs.

The microcontroller (nRF52832) has been selected to manage the different inputs/outputs coming from the sensors. It is characterized by supply voltage range of 1.7 V–3.6 V, 12-bit resolution, 200 kbps ADC and 8 configurable channels with programmable gain. It supports up to 2x I2C compatible 2-wires master/slave and is based on the Bluetooth® Low Energy communication protocol for 2.4GHz ultra low-power wireless applications. This component has been selected to provide the required computation and transmission capabilities to the system, and to reduce the power consumption with increased battery charge.

The evaluation board for electronic system testing has been designed with nine functional areas, supported by additional functions: power management and storage/service areas. The functional areas are reported in Fig. 1.

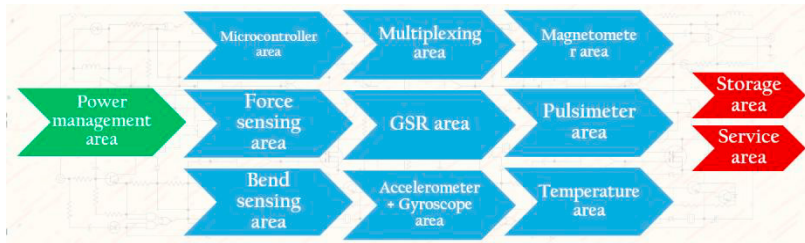

Figure 1. Functional areas of the electronic evaluation board.

After selecting the electronic components and identifying the proper conditioning scheme for every sensor, the circuit layout of the overall evaluation board has been designed.

The power management area provides the board supply with four alternative methods: 1) micro USB cable, 2) DC power jack/connector compatible with DC wall supplies, 3) connector for lithium-ion polymer (LiPo) battery, 4) two generic male headers.

The storage area includes two storage devices: a) micro SD with 15x11x1mm³ dimensions, and b) EEPROM with 1Mb size.

4. Evaluation board assembling and testing

The evaluation PCB is fabricated by 4 conductive layers with the configuration of Fig. 2. The evaluation board is then completed by soldering the electronic components and by validating the electric connection and interferences. The acquisition rates and processing capabilities have been also tested and verified. The final layout of the board is reported in Fig. 3.

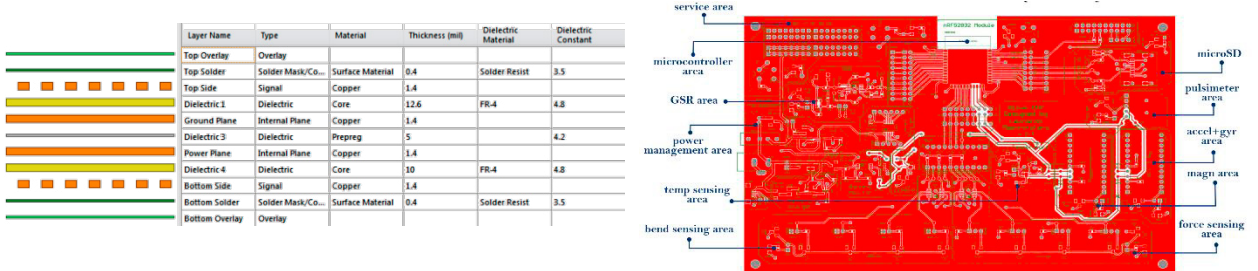

Figure 2. Conductive layers structure of PBC evaluation board and overall design including components footprints and vias.

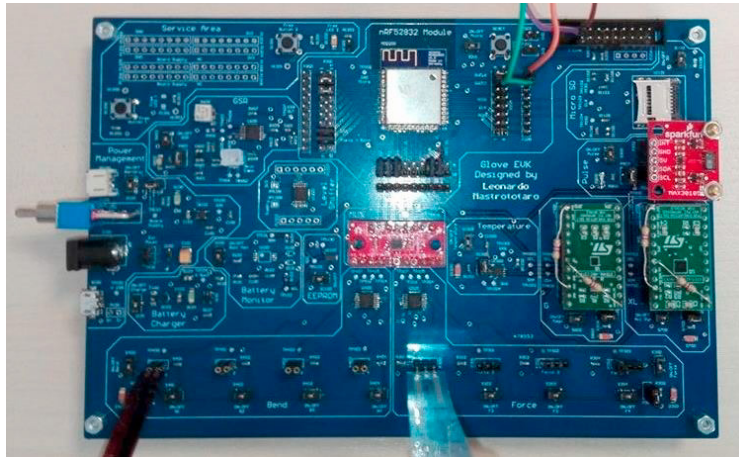

Figure 3. Final configuration of the assembled evaluation board.

5. Miniaturization

After validation of components compatibility, the further activity of miniaturization is addressed to scale down the circuit size at the dimensions compatible to the integration on a hand. Some redundant components have been removed, as LEDs, tactile buttons/switches and headers present in the service area of the evaluation board. Only the supply ports with Micro USB and to LiPo battery have been preserved. Only the EEPROM storage device has been maintained. Some components have been replaced with others having smaller dimensions, or able to integrate different functions; in particular the TPS65721 component able to integrate a voltage controller (1.8, 3.3 and 5.0 V), to pilot two LEDs, and to control the LiPo battery charge has been introduced. At the same time, the LDO voltage controller (3.0 V), the battery charge circuit and the battery level monitoring circuit have been removed. The previous microcontroller has been replaced with the EYSHSNZWZ, by Taiyo, with smaller size (8.55x 3.25 mm²).

The final schematics of the circuit layout of miniaturized electronic controller is reported in Fig. 4.

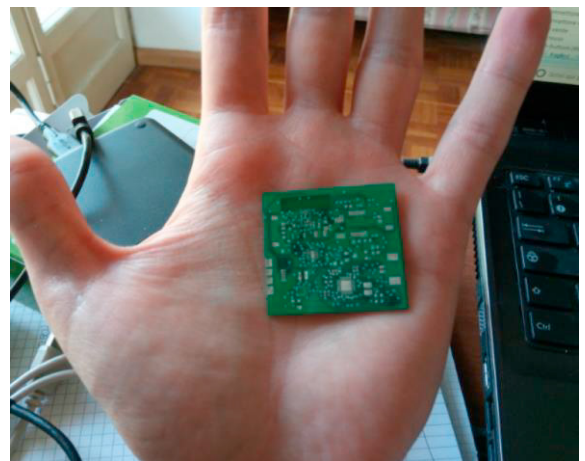
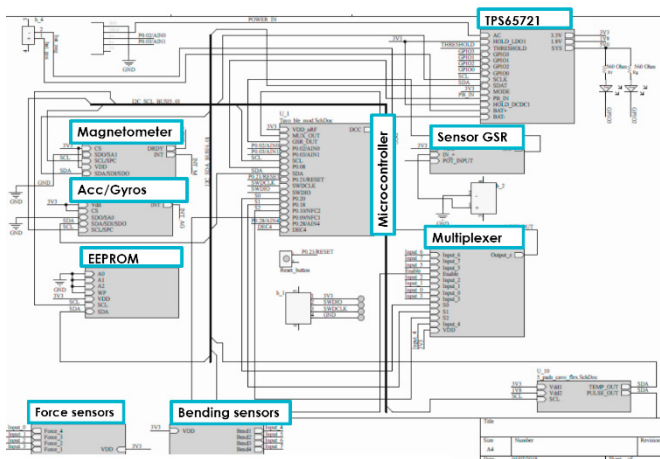

Figure 4. Final layout configuration and image of the miniaturized control circuit.

6. Conclusions

The design specifications of the sensing system for upper limbs in neurologic rehabilitation have been identified by analyzing the traditional trainings. Sensors typologies and quantities to measure have been defined. The evaluation board integrating the required sensing capabilities and additional functions as power management and data storage is designed and fabricated. After compatibility and functional tests, the board has been redesigned to scale down its dimensions to about 30x30mm, compatible to the size of hand backside. The final miniaturized circuit is suitable for integration in wearable gloves and controlled by specific firmware able to operate all the desired functions.

Acknowledgments

The authors thank Dr. Burin and Prof. Pia from University of Torino, Department of Psychology, for the support provided in the definition of the device specifications.

References

- Büscher, G.H., Kõiva, R., Schürmann, C., Haschke, R., Ritter, H.J., 2015. Flexible and stretchable fabric-based tactile sensor,” *Robotic Autonomous Systems* 63, 244–252.
- De Pasquale, G., Mastrototaro, L., Pia, L., Burin, D., 2018. Wearable system with embedded force sensors for neurologic rehabilitation trainings. *Proc. of DTIP, Roma, Italy*.
- De Pasquale, G., Mastrototaro, L., Ruggeri, V., 2018. Wearable sensing systems for biomechanical parameters monitoring. *Material Today*, in press.
- De Pasquale, G., Kim, S.G., De Pasquale, D., 2016. GoldFinger: wireless human–machine interface with dedicated software and biomechanical energy harvesting system. *IEEE/ASME Transactions on Mechatronics* 21(1), 565–575.
- De Pasquale, G., Kim, S.G., De Pasquale, D., 2015. Optical HMI with biomechanical energy harvesters integrated in textile supports, *proc. of PowerMEMS, Boston, USA. Journal of Physics: Conference Series* 660, 012031, 2015.
- De Pasquale, G., Mura, A., 2018. Accelerated lifetime tests on e-textiles: design and fabrication of multifunctional test bench. *Journal of Industrial Textiles* 47(8), 1925–1943.
- De Pasquale, G., 2016. Artificial human joint for the characterization of piezoelectric transducers in self-powered telemedicine applications. *Meccanica* 51(9), 2259–2275.
- De Pasquale, G., 2015. Biomechanical energy harvesting: design, testing, and future trends in healthcare and human-machines interfacing. In: “Innovative materials and systems for energy harvesting applications”, L. Mescia, O. Losito, F. Prudeniano, IGI Global - Engineering Science Reference (USA), 290–340.
- Dipietro, L., Sabatini, A.M., Dario, P., 2003. Evaluation of an instrumented glove for hand-movement acquisition. *Journal of Rehabilitation Research and Development* 40 (2), 179.
- Gentner, R., Classen, J., 2009. Development and evaluation of a low-cost sensor glove for assessment of human finger movements in neurophysiological settings. *Journal of Neuroscience Methods* 178(1), 138–147.
- Swallow, L., Siores, E., 2009. Tremor Suppression Using Smart Textile Fibre Systems. *Text. Bioeng. Informatics Symp. Proceedings*, 142–146.
- Williams, N.W., 1997. The virtual hand. *Journal of Hand Surgery* 22B(5), 560–567.
- Williams, N.W., Penrose, J.M.T., Caddy, C.M., Barnes, E., Hose, D.R., Harley, P., 2000. A goniometric glove for clinical hand assessment: construction, calibration and validation. *Journal of Hand Surgery* 25(2), 200–207.
- Zimmerman, T., “Optical flex sensor,” U.S. Patent 4 542 291, 1982.