

A Fuzzy Approach for Reducing Power Consumption in Wireless Sensor Networks: A Testbed With IEEE 802.15.4 and WirelessHART

Original

A Fuzzy Approach for Reducing Power Consumption in Wireless Sensor Networks: A Testbed With IEEE 802.15.4 and WirelessHART / Collotta, Mario; Ferrero, Renato; Rebaudengo, Maurizio. - In: IEEE ACCESS. - ISSN 2169-3536. - STAMPA. - 7:(2019), pp. 64866-64877. [[10.1109/ACCESS.2019.2917783](https://doi.org/10.1109/ACCESS.2019.2917783)]

Availability:

This version is available at: [11583/2734792](https://doi.org/10.11583/2734792) since: 2020-06-29T16:32:06Z

Publisher:

IEEE

Published

DOI:[10.1109/ACCESS.2019.2917783](https://doi.org/10.1109/ACCESS.2019.2917783)

Terms of use:

This article is made available under terms and conditions as specified in the corresponding bibliographic description in the repository

Publisher copyright

(Article begins on next page)

Received April 2, 2019, accepted May 3, 2019, date of publication May 20, 2019, date of current version May 31, 2019.

Digital Object Identifier 10.1109/ACCESS.2019.2917783

A Fuzzy Approach for Reducing Power Consumption in Wireless Sensor Networks: A Testbed With IEEE 802.15.4 and WirelessHART

MARIO COLLOTTA¹, (Member, IEEE), RENATO FERRERO², (Member, IEEE), AND MAURIZIO REBAUDENGO², (Senior Member, IEEE)

¹Laboratorio di Ingegneria Informatica e Reti, Università degli Studi di Enna "Kore," 94100 Enna, Italy

²Dipartimento di Automatica e Informatica, Politecnico di Torino, 10129 Turin, Italy

Corresponding author: Renato Ferrero (renato.ferrero@polito.it)

ABSTRACT The rapid growth in the adoption of wireless sensor networks (WSNs) is motivated by the advantages offered with respect to wired systems, such as cost-effectiveness, easiness of installation, scalability, flexibility, and self-organization. However, due to their nature, the nodes in WSN rely on a limited energy source; therefore, an efficient communication among the nodes is desirable to prolong the lifetime of the WSN. In particular, the alternation of active and sleep states and the regulation of the transmission power represent two common approaches to save energy. This paper proposes the simultaneous use of two fuzzy logic controllers to dynamically adjust the sleeping time and the transmission power of the nodes in order to optimize energy consumption. The experimental results show a network lifetime improvement ranging from 30 to 40%, according to the adopted Medium Access Control (MAC) protocol.

INDEX TERMS Fuzzy logic controller, sleeping time, transmission power, industrial WSN.

I. INTRODUCTION

In a wireless sensor network (WSN), a large number of small and autonomous nodes are deployed to sense and monitor the environment. Nodes communicate with each other via radio frequency waves to convey the acquired information to a *base station*, by means of single or multiple hops. The base station is a more powerful node for interfacing the WSN with the end user, as it generally forwards the received data to a server. The adoption of WSNs in industrial environments has recently increased due to several advantages with respect to traditional wired industrial systems [1]. Installation and re-location of the monitoring system are expedited, with better scalability, flexibility and self-organization. Cost-effectiveness represents another advantage, due to the absence of expensive communication cables and reduced costs for regular maintenance. However, due to requirements of low cost and miniaturization, the nodes of a WSN are resource-constrained, with limited memory and computation capability. In addition, the nodes are usually battery-supplied, so energy becomes the most limiting factor as it

directly affects the network lifetime [2]. Energy is mainly consumed in sensing, computing, and transmitting data; among them, transmission is by far the highest power consuming activity [3]. Therefore many solutions for energy efficient communication have been proposed at different levels of the protocol stack, mainly at network, data link and application layer.

At the network layer, a routing protocol can be adopted to find the communication path that minimizes the energy consumption [4], [5]. In addition, the nodes can be grouped by means of a clustering algorithm: in this way, the data collected by the nodes of a cluster can be aggregated and reduced by the cluster head before being transmitted, with a consequent energy saving [6]–[9].

At the data link layer, a Medium Access Control (MAC) protocol can provide energy-efficient mechanisms to control multiple accesses to the wireless channel [10], [11]. Different MAC protocols have been proposed according to the network properties. The IEEE 802.15.4 standard [12] regulates the wireless communication of low-power, low-data-rate, short-range devices. It defines two operating modes: *active* and *sleep*. Nodes are active only when they have to transmit or they expect to receive data, otherwise they enter

The associate editor coordinating the review of this manuscript and approving it for publication was Jinpeng Yu.

into the sleep mode and they switch off their modules to save power. An alternative protocol, especially adopted in process automation applications, is the WirelessHART open standard [13], which is characterized by a high data rate and a severe security policy.

At the application layer, regulating the sampling time (i.e., the rate of the environment measurements) can affect the network lifetime [14]–[16]. A high sampling time minimizes the energy consumption, since few measurements are required, but it also penalizes the reactivity and effectiveness of the WSN, due to the latency in recognizing environmental changes.

Also the transmission power can be adjusted to achieve a good trade-off between the network lifetime and the quality of service (QoS) of the application [17]–[20]. On one hand, if the transmission power is too high, the node wastes energy and its signal is more likely to disturb other nodes. On the other hand, a too low transmission power increases the probability of packet loss, because the signal-to-interference ratio (SIR) measured at the receiver's antenna decreases.

Among the described approaches, the most direct way to limit the power consumption is by adjusting the transmission power and sleeping time. Communicating with minimum transmission power can dramatically reduce power consumption: as an example, the wireless module MRF24J40MA¹ consumes 130 mAh if the transmission is performed at maximum power (0 dBm), but it requires only 91 mAh if the transmission power is reduced to the lowest value of -30 dBm, with 30% energy saving. The effect of prolonging the sleeping time is even more striking: as long as the node stays in the sleep mode, its power consumption can be considered negligible. Considering the same example, the module MRF24J40MA consumes only $2 \mu\text{A}$ in the sleep mode. Although extremely advantageous from the energetic point of view, spending most of the time in the sleep mode and communicating at minimum transmission power can be impractical. The node cannot accomplish its tasks because few data samples would be transmitted during short active phases and they would be detected only at close distance.

In this paper, two *fuzzy logic controllers* (FLCs) are proposed to dynamically adjust the transmission power and the sleeping time in order to find the proper trade-off between the power saving and the WSN performance. Fuzzy logic is widely adopted in WSNs [21], [22] because it can deal with uncertain and vague values, such as clock drifts and interference between nodes. In these cases, an exact computation may be too complex and it could also be meaningless due to the quick variation of the network parameters. The novelty of the proposal is the use of two FLCs in parallel for adjusting both the transmission power and the sleeping time. The FLCs operate at the data link layer, but their adoption do not imply any change to the protocol stack, as they only need primitives for adjusting the sleeping time. In addition, the implementation of the proposed approach requires two

kinds of control packets exchanged at the application layer, in order to inform on the input and output parameters of the FLCs.

The benefits of the proposed technique are confirmed by practical validations, whereas, to the best of our knowledge, all other state-of-the-art approaches were evaluated only by means of simulations. The energy savings due to the adoption of FLCs in IEEE 802.15.4 networks have been already shown in [23], although the advantages have been estimated only by means of simulations. This paper proves the validity of the approach to other MAC protocols, by extending the analysis to WirelessHART. In addition, it validates the results by means of two testbed scenarios.

The main novelties of this paper are:

- simultaneous use of two FLCs in order to regulate both transmission power and sleeping time at the application layer. In literature, energy-efficient solutions based on fuzzy logic focus on either one of the two parameters, and they exploit one FLC only.
- applicability of the proposed solution to two main standardized MAC protocols, i.e., IEEE 802.15.4 and WirelessHART. Instead, other fuzzy logic based methods are either compliant to only one standard, or they require changes to the standard, or they do not provide details at the data link layer.
- special attention to industrial applications with deadline-aware requirements. In this case, the number of packets sent in time is considered more important than the throughput in itself, i.e., the total number of packets sent. Other state-of-the-art methods have a different vision, such as quality of service and throughput, which can be suitable for different application fields.
- evaluation of the performance by means of a real implementation, whereas, to the best of our knowledge, the benefits of all similar solutions are shown only by means of simulations.

The remaining of this paper is organized as follows. Section II introduces the main concepts about the IEEE802.15.4 and WirelessHART standards. Section III reviews existing approaches for saving energy by adjusting the transmission power and the sleeping time. The proposed mechanism is presented in Section IV. The tested scenario and the simulation results are described in Section V. The obtained results are validated with a real implementation in Section VI. Finally, some conclusions are drawn in Section VII.

II. MAC PROTOCOLS FOR INDUSTRIAL WSN

An open issue in industrial WSNs concerns the constraints of low-power sensor nodes, especially when the application requires frequent data communication, which increases power usage. This section presents the most relevant WSN standards that have been designed to manage the limited node resources.

The IEEE 802.15.4 standard defines physical and MAC layer for low-power, low-data-rate, personal area WSNs. It provides a MAC superframe composed of a *contention*

¹<http://ww1.microchip.com/downloads/en/DeviceDoc/70329b.pdf>

access period, when the data transmission is regulated by means of a Carrier Sense Multiple Access with Collision Avoidance (CSMA/CA) technique, and a *contention free period*, when up to 7 devices can transmit by means of the *guaranteed time slot* mechanism. A limitation of IEEE 802.15.4 is the absence of a frequency hopping technique. As a consequence, communication may be highly affected by noise and interference, which usually characterize industrial networks.

IEEE 802.15.4 has been adopted by a majority of WSN standards, most notably the series of standards from ZigBee. All subsequent industrial WSN standards are built on top of IEEE 802.15.4. Among new standards, WirelessHART [13] is particularly promising for industrial applications. WirelessHART implements a subset of IEEE 802.15.4, but it adds many specifications in its own Data Link Layer (DLL) to address some critical requirements for industrial environment.

WirelessHART provides five levels of the ISO/OSI protocol stack: physical, data link, network, transport and application layer. It offers a network manager for communication scheduling and routing among nodes. WirelessHART works in the 2.4 GHz band with a maximum data rate of 250 kbit/s and 16 channels spaced by 5 MHz guard band. The data link layer can be divided into time slots of 10 ms. WirelessHART uses TDMA as medium access technique, in order to limit the unpredictability of the communication. In addition, it manages a black list of channels suffering from interference and, in this way, it is possible to disable channels affected by noise.

Several differences between IEEE 802.15.4 and WirelessHART have been carried out in the literature [24]. WirelessHART imposes a strict limit on the duration of the TDMA slots, which are fixed to 10 ms, therefore it is not as flexible as IEEE 802.15.4 in terms of superframe duration and beacon interval. On the other hand, WirelessHART uses multiple radio channels, in order to improve network performance. Despite their differences, IEEE 802.15.4 and WirelessHART are equally considered as two of the most suitable protocols for industrial WSNs, as they enable low-rate and low-power communication.

III. RELATED WORK

Fuzzy logic-based solutions are commonly adopted in WSN because they can handle uncertainties in the design and management of the network. FLCs can accomplish many tasks and they affect different layers of the protocol stack.

At the network layer, fuzzy logic can help in partitioning the WSN into clusters. Clustering improves the communication efficiency and network scalability because the data collected by the nodes of a cluster are aggregated by the cluster-head. Then, the cluster-head sends the gathered data to the base station. Due to their heavier tasks with respect to the other nodes of the cluster, the cluster-headers are selected among the nodes with more residual energy. Furthermore, cluster-headers close to the base station consume even more energy because they communicate more frequently with the

base station. This issue is addressed with unequal clustering algorithms: they look for network partitions such that the clusters near the base station are smaller than the clusters far from it. In particular, the fuzzy energy-aware unequal clustering (EAUCF) algorithm exploits an FLC to determine an unequal clustering [8]. For every node, the FLC considers the residual energy and the distance with the base station in order to compute the *competitive range* of the node. Then, the nodes exchange messages with the value of their competitive range and their residual energy. If a node receives a message by another node inside its competitive range with a higher residual energy, then the receiving node leaves the cluster-head competition. The remaining nodes are selected as cluster-heads. EAUCF is improved by the fuzzy based unequal clustering (FBUC) algorithm [9]. The fuzzy rules applied in FBUC consider also the node degree, besides its residual energy and the distance with the base station, in order to compute the competitive range.

At the data link layer, fuzzy-logic based strategies can be adopted for coordinating the channel access. For example, MAC protocols often rely on perfect network time synchronization for scheduling the transmission and reception phases of the nodes. However, clock drifts introduces inaccuracies among nodes. An FLC can take into account the effect of the clock drifts and delay or anticipate the packets scheduling accordingly [11]. Every node is supposed to have a limited buffer for temporarily storing the received packets before processing them. If the buffer is filled up, the next incoming packets are discarded. The FLC evaluates the ratio of nodes with overflowed buffer, the ratio of nodes with high failure rate in their transmission, the ratio of nodes that did not synchronize their communication with another node due to clock drifts. The output of the FLC is the variation (high increase, increase, no change, decrease, high decrease) of the adjustment factor. The adjustment factor is multiplied by the length of the previous interval of schedule broadcast in order to compute the length of the new interval.

At the application layer, fuzzy logic systems are adopted to adjust the behavior of the nodes. In particular, great effort is devoted to power savings, as the batteries that feed nodes are a limited source of energy. The transmission power directly impacts on the energy balance, because transmission is the highest power consuming activity of a node. In addition, instead of being active all the time, a node can save energy by sensing and communicating periodically, i.e., with a proper sampling and sleeping time. The next two subsections review state-of-the-art solutions that optimize energy consumption by dynamically adjusting transmission power, sampling and sleeping time with an FLC. Then, a widespread approach, which is an alternative to FLC, is presented in the third subsection.

A. FUZZY LOGIC FOR ADJUSTING TRANSMISSION POWER

In the literature, different parameters have been considered for controlling the transmission power, such as the QoS of

the communication, the distance between the sender and the receiver and the number of available receivers.

When data packets are exchanged between two nodes, the receiver has the opportunity to evaluate the QoS of the communication in order to adjust the power level of its future transmissions [17]. In particular, the Link Quality Indicator (LQI) is chosen as a QoS representative, since this parameter indicates the quality of the received signal by estimating how easily it can be demodulated. The FLC decides the variation of the transmission power by evaluating the LQI of the current communication and the LQI of the previous one. This approach can reduce the packet error rate and prolong the WSN lifetime.

The idea that the transmission power should depend on the distance between sender and receiver has led to the development of a MAC protocol compliant with IEEE 802.15.4 [19]. Since the nodes do not know the position of their neighbors, the distance between two communicating nodes is assumed as directly related to LQI and to the Received Signal Strength Indicator (RSSI), which is the measurement of the power of the received signal. An FLC regulates the transmission power according to the average values of LQI and RSSI during the monitored interval. An additional increment of the transmission power can be applied if more than two error frames are detected in the monitored interval. An energy saving of 11%, without any throughput loss, was claimed and a further enhancement may be obtained by considering also the ratio of the number of errors to the total number of transmitted bits [18].

The transmission power directly affects the degree of a node: if it increases, the node can send data to a wider distance and its degree becomes higher. Therefore, an FLC has been proposed for adjusting the transmission power of the nodes according to their degree [20]. The inputs of the FLC are the error e_d of the node degree and the ratio of e_d to the variation of the transmission power in the last period of time. The FLC defines, as output, the transmission power in order to optimize the energy consumption of the WSN.

B. FUZZY LOGIC FOR ADJUSTING SAMPLING AND SLEEPING TIME

The data packets that a node sends after sensing the environment may be lost or arrive at the base station with a delay larger than the deadline, resulting in both cases as a deadline miss. The number of deadline misses is related to the sampling time: a low sampling time increases the traffic load on the network, with higher probabilities of node collisions and deadline misses. An FLC can limit the deadline miss ratio by adjusting the sampling time according to traffic conditions [14]. In details, the FLC regulates the sampling period by acquiring two inputs: firstly, the error e_m between the current deadline miss ratio and the desired tolerable one; secondly, the change of e_m between two consecutive intervals. The Dynamic Sampling Algorithm (DSA) further extends the network lifetime by evaluating also the remaining battery capacity of each node [15].

IEEE 802.15.4 offers primitives for changing sleeping and wake-up time, so the sampling time can be adjusted without affecting the MAC layer. Many variations to IEEE 802.15.4 have been proposed in order to improve energy savings, but they do not offer a general technique for regulating the sampling time, due to their different management of the duty cycle mechanism. For some MAC protocols, either synchronous or asynchronous, there are specific solutions that exploit an FLC to dynamically adjust the duty cycle, and consequently the sampling time.

S-MAC is a popular synchronous MAC protocol, which divides time into frames [25]. Each frame is composed of a listen and a sleep interval. A node starts transmitting during the listen interval of the receiver; then the data transfer continues during the whole frame. On the other hand, the nodes that do not participate to the communication switch off their radios during the sleeping interval. A node notifies its scheduling to the others by means of a special control signal. A group of nodes that share the same sleeping time form a virtual cluster. With neighbors belonging to different virtual clusters, a node needs a higher duty cycle in order to follow any listen intervals. As a countermeasure, an FLC can dynamically regulate the duty cycle of the nodes based on the density of their neighborhood. The reduction of the wake up time is theoretically proven [26].

In asynchronous MAC protocols, the nodes rely on mechanisms different from synchronization to initiate a data packet exchange. For example, with preamble sampling technique [27], a node sends a long preamble before transmitting useful information. In this way, the receiver saves energy since it is not forced to sample the channel continuously: it is sufficient that the sampling time is shorter than the preamble length. Strobed preamble sampling protocols offer an enhancement of this basic approach: instead of a single meaningless preamble, the sender transmits a series of shorter preambles with the address of the receiver. Consequently, the receiver can limit the preamble phase by means of an acknowledge signal. Simulations show that, when a strobed preamble sampling protocol is adopted, the lifetime of the network can be extended if an FLC regulates the sleeping time of each node by evaluating its remaining battery energy and the average number of data packets that it has to transmit [28].

C. PROPORTIONAL CONTROLLER

A *proportional controller* (P controller) uses a feedback mechanism for dynamically regulating a parameter of the WSN. The output of the P controller is proportional to the error of the monitored parameter, i.e., the difference between the target and the current value. For example, the transmission power P_{TX} can be computed according to the error of the signal-to-noise ratio (SNR) [29]:

$$P_{TX}(k) = P_{TX}(k-1) + K_p \cdot (SNR_p - SNR_c) \quad (1)$$

where K_p expresses the proportional gain, SNR_p is the predefined value of SNR to obtain the desired Packet Reception Rate (PRR), and SNR_c is the value of SNR measured by

the receiver and then communicated to the sender. The P controller is aimed to reduce the packet loss caused by the interference among nodes due to concomitant transmissions.

The *proportional-integral-derivative controller* (PID controller) is a more complex control system:

- the proportional term takes into account the present error of the monitored parameter;
- the integral term depends on the accumulation of past errors;
- the derivative term predicts the future error.

A PID controller can adjust the transmission power as follows [30]:

$$P_{TX}(k) = K_p e_d(k) + K_i \sum_{j=0}^k e_d(j) + K_d [e_d(k) - e_d(k-1)] + P_{TX}^0 \quad (2)$$

where K_p , K_i , and K_d are constants; P_{TX}^0 is the output of the controller when the error e is null; $e_d(k) = d_d(k) - d_c(k)$ is the error of the node degree, i.e., the number of other nodes in the WSN that can be reached in one hop; $d_c(k)$ is the current node degree, and $d_d(k)$ is the desired value.

IV. PROPOSED APPROACH

Both sleeping time and transmission power of sensor devices are dynamically adjusted by means of two FLCs. The first controller determines the sleeping time, and the second one regulates the transmission power. The two controllers are described in Sections IV-A and IV-B.

The two FLCs can be implemented on each node of the WSN. In this way, a node autonomously computes its optimal settings based on the available inputs. However, this solution may be not viable because a node may have to satisfy strict constraints of cost and miniaturization, which prevent adding extra hardware for the FLCs. Two alternatives are possible, depending if the number of hops to reach the base station is fixed to one (single-hop network) or not (multi-hop network).

In a single-hop network, the FLCs are implemented in the base station and compute sleeping time and transmission power for every node. The information about the input and output of the FLCs is exchanged through control packets in the same way as the data packets are. The increase in the network traffic is negligible, because the control packets are sent only when there are significant variations of the parameters, whereas the data packets are regularly sent at every sampling. This is confirmed by the experimental test in Section VI.

In a multi-hop network, a node can be too far from the base station, so providing the data for the FLCs and receiving their response would require several hops, thus affecting the network traffic. As a countermeasure, the node can delegate the computation of its optimal working parameters to a more powerful node, equipped with the FLCs and reachable in a single hop. If such kind of node is not present nearby, then a special node, called *network controller*, is locally added

to the WSN. The network controller is properly equipped for executing computational tasks; in particular, it offers the implementation of the FLCs. In that way, each node directly communicates with another entity (i.e., a close node or a network controller) to be configured: the impact on the network traffic is negligible, as it would be in a single-hop network.

The proposed approach can be applied both in centralized and distributed networks. In a centralized WSN, the FLCs are implemented in the base station and the nodes exchange control packets with it to receive their configuration. However, in order to limit the network traffic, it is recommended that the centralized network is single-hop. If it is not the case, the computation of the sleeping time and transmission power should be distributed by exploiting existing nodes, powerful enough to be equipped with the FLCs, or by inserting some network controllers into the WSN.

A. SLEEPING TIME MANAGEMENT

The sleeping time of the devices is dynamically calculated by the first controller, called FLC₁, by processing the battery level and the throughput to workload ratio. The throughput is the number of packets sent by the device. The workload is computed as the number of packets that the device has to send, either periodic or aperiodic. The number of aperiodic packets N_a cannot be known *a priori* and, as a consequence, it can be considered as a random variable, whereas the number of periodic packets corresponds to the number of samples N_s and can be computed as follows:

$$N_s = \sum_{t=T_{start}}^{T_{end}} \chi(t) \quad (3)$$

where T_{start} and T_{end} represent initial and final instants of the sleep phase respectively; $\chi(t)$ is a step function defined as

$$\chi(t) = \begin{cases} 0 & t \bmod T_s \neq 0 \\ 1 & t \bmod T_s = 0 \end{cases} \quad (4)$$

where T_s is the sampling time of the node, which coincides with the packet emission time. Th/Wl is calculated as:

$$Th/Wl = \frac{k + N_a}{N_s + N_a} \quad (5)$$

where k is the number of periodic packets sent by the device when it wakes up: only the k -most recent samples (out of N_s) acquired during the sleeping time are transmitted. Taking into account the example reported in Fig. 1, let assume that the sleep phase begins at $T_{start} = 5$ and ends at $T_{end} = 9$. With a sampling period $T_s = 2$, two periodic packets are counted during the sleep phase. Consequently, Th/Wl is computed as:

$$Th/Wl = \frac{k + N_a}{N_s + N_a} = \frac{1 + 1}{2 + 1} = 0.66 \quad (6)$$

where $k = 1$ means that only the last periodic packet is sent.

Th/Wl and battery level are both processed by FLC₁. The first step is represented by fuzzification, i.e., the estimation of the grade of membership of a crisp input value. In detail, three

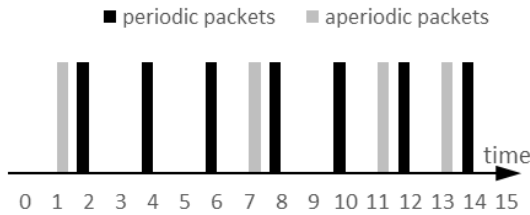

FIGURE 1. Th/Wl computation.

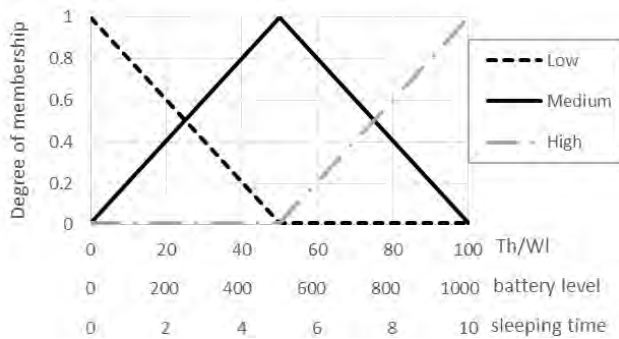

FIGURE 2. Membership functions of I/O parameters for FLC_1 .

membership functions (Low, Medium, High) are defined for each input variable. The range of these crisp values is:

- Th/Wl : [0, 100] in percentage;
- battery level: [0, 1023], which is the range of the output of a 10-bit analog-to-digital converter ADC) used to measure the charge of the battery.

Similarly, three membership functions (Low, Medium, High) are defined for the sleeping time. The range of the crisp values of this output variable is: $[1, 10] \cdot T_s$, where T_s is a constant value defined at design time. Several simulations have been performed in order to choose the most appropriate shape for the membership functions, as described in Section V-A. The simplest membership function is the triangular one; the simulations reveal that other common functions do not lead to any relevant improvement in performance, at the cost of an increase in computational overhead. The fuzzy triangular membership functions of Th/Wl , battery level and sleeping time are shown in Fig. 2, where the degree of membership is represented by normalized values [0 - 1].

At the second step, the fuzzy controller applies 9 inference rules to determine the output fuzzy value. The rules are based on IF-THEN statements of standard programming languages. The most promising sets of rules were selected among all possible combinations, and then experimentally compared, as explained in Section V-B. The best performing set of rules is listed in Table 1. As an example, let us consider rule 9: if both Th/Wl and battery level are high, then the sleeping time will be high. In fact, under these conditions it is advisable to maintain the device in the sleep state as much as possible.

The last step is represented by defuzzification, i.e., the conversion of the output fuzzy value into a new crisp value

TABLE 1. FLC_1 inference rules.

Rule	Antecedent (Th/Wl)	Antecedent (battery level)	Consequent (sleeping time)
1	Low	Low	Medium
2	Low	Medium	Low
3	Low	High	Low
4	Medium	Low	Medium
5	Medium	Medium	Medium
6	Medium	High	Low
7	High	Low	High
8	High	Medium	High
9	High	High	High

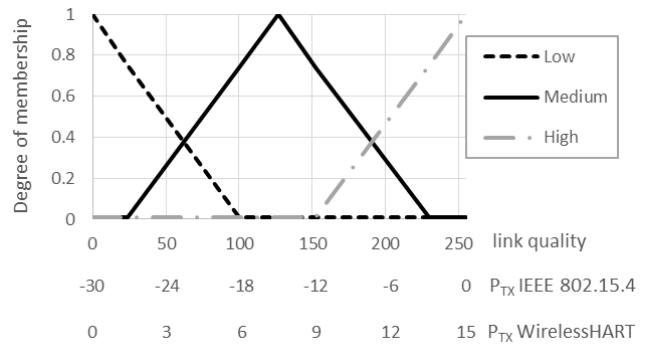

FIGURE 3. Membership functions of I/O parameters for FLC_2 .

by means of the centroid mechanism:

$$sleeping\ time = \frac{\sum_{i=1}^n Out_i \cdot C_i}{\sum_{i=1}^n C_i} \quad (7)$$

where Out_i is the output of the i -th rule, and C_i is the center of the output membership function.

B. TRANSMISSION POWER MANAGEMENT

Three membership functions (Low, Medium, High) are defined for the input variables of the second fuzzy controller, called FLC_2 . Their crisp values range as follows:

- battery level: [0, 1023], defined in the same way as for FLC_1 ;
- link quality [0, 255], where 0 represents the worst link quality value. This parameter is determined by means of the RSSI value, stored in a register of the transceivers.

The membership function for battery level is the same as used by FLC_1 , whereas the one for link quality is shown in Fig. 3. The membership functions defined for the output variable P_{TX} have the same shape as in Fig. 3. The range of their crisp values depends on the adopted protocol:

- P_{TX} : [-30, 0] dBm in case of IEEE 802.15.4.
- P_{TX} : [0, 15] dBm in case of WirelessHART.

As for FLC_1 , also the output fuzzy value of FLC_2 is determined through 9 fuzzy rules (which are listed in Table 2), and then defuzzified using the centroid formula, as in (7).

TABLE 2. FLC₂ inference rules.

Rule	Antecedent (battery level)	Antecedent (link quality)	Consequent (P_{TX})
1	Low	Low	Medium
2	Low	Medium	Medium
3	Low	High	Low
4	Medium	Low	Medium
5	Medium	Medium	High
6	Medium	High	Low
7	High	Low	High
8	High	Medium	Medium
9	High	High	Low

V. SIMULATION SCENARIO

The battery consumption with the proposed approach is firstly evaluated by means of a model built in Simulink/Matlab, as shown in Fig. 4. The input parameters of the *FieldDevice* block are an *aperiodic* number, the sleeping time and the transmission power. The *aperiodic* number is generated through a uniform random number block and represents the number of aperiodic packets N_a transmitted by the device. Sleeping time and transmission power are acquired through a feedback loop system. In details, the two memory loop blocks store the last values computed by the two parallel FLCs in the right-hand side of the model. The *FieldDevice* block uses the transmission power and sleeping time stored in the memory loop blocks until new values are computed by the FLCs. The output values of the *FieldDevice* block are used as input variables by the two parallel FLCs in the right-hand side of the model.

The battery level trend is managed into the *FieldDevice* block through the Simulink/Stateflow environment, an internal Matlab tool that allows to describe the evolution of a

specific system (in this case the battery trend) by means of a finite state machine, which is reported in Fig. 5.

The model shown in Fig. 4 represents the node activity from the implementation of the proposal. Firstly, the node can be regarded as a single entity, which sends periodic and aperiodic packets to the external world, so it is viewed as independent of the architecture of the WSN (i.e., centralized/distributed, single-hop/multi-hop). Secondly, the behavior of a node is not affected by the way it obtains the values of its sleeping time and transmission power. Since the network traffic is not evaluated at this phase, there is no practical difference for a node between computing its optimal configuration by itself and receiving the value from the network controller.

The power consumption of a device depends on its activity state. In sleep mode, the power consumption is $PC_{sleep} = PC_{\mu C} + PC_t$, where $PC_{\mu C}$ is the power consumed by the microcontroller for data acquisition and elaboration, and PC_t is the consumption of the transceiver. In practice, PC_{sleep} is mainly due to $PC_{\mu C}$, since PC_t is negligible.

The proposed approach is intended for industrial applications, so the parameters used in the simulations are set according to common system requirements in factory automation [31]. In particular, N_a is a random value uniformly distributed in the interval [0, 5]. Moreover, the power consumption is obtained from the datasheets of the following microcontroller and wireless modules:

- 16 bit MCU - Microchip PIC24F family²;
- MRF24J40MA Radio Frequency Transceiver IEEE 802.15.4 2.4 GHz;
- VersaNode 310 2.4 GHz Wireless Radio Module³.

According to datasheets, $PC_{\mu C} = 50 \text{ mAh}$, $PC_{wm} = 5 \text{ }\mu\text{Ah}$ for the IEEE 802.15.4 module, and $PC_{wm} = 40 \text{ }\mu\text{Ah}$ for the WirelessHART module.

The consumption of a node in sleep mode is estimated as:

$$PC_{sleep} = \frac{PC_{\mu C} \cdot \text{maxbit}}{\text{fullCharge} \cdot 3600} \text{ bit/s} \tag{8}$$

where *fullCharge* is the maximum charge level of the battery, *maxbit* is its digital value and 3600 is the number of seconds in an hour. In a 10.8 V lithium-ion battery, *fullCharge* = 3100 mAh: the corresponding digital value, acquired through a 10 bit ADC, is 1023. Then, the power consumption of a device in sleep mode can be computed as:

$$PC_{sleep} = \frac{50 \cdot 1023}{3100 \cdot 3600} = 0.00458 \text{ bit/s} . \tag{9}$$

When the device is transmitting, the battery consumption is $(0.00458 + P_{TX}) \text{ bit/s}$. The consumption of the IEEE 802.15.4 transceiver is 130 mAh in case of maximum P_{TX} (0 dBm), but it drops at 91 mAh in case of minimum P_{TX} (-30 dBm). The consumption of the VersaNode

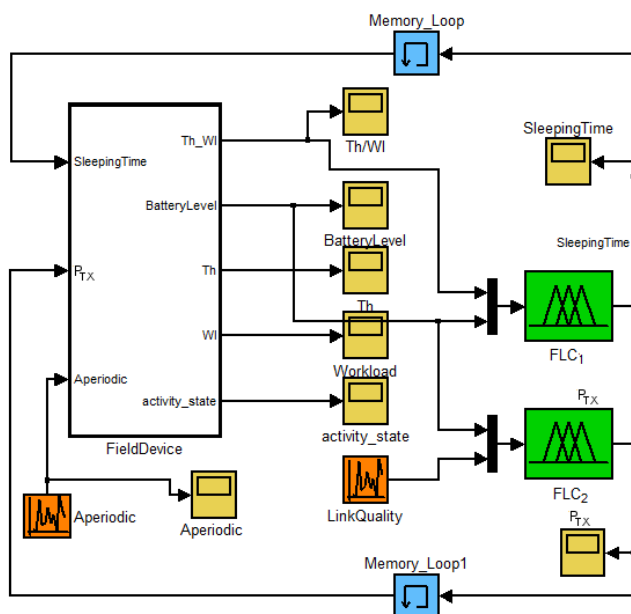

FIGURE 4. Simulator scheme.

²<http://ww1.microchip.com/downloads/en/DeviceDoc/39897c.pdf>

³http://www.nivis.com/products/datasheets/Nivis_VersaNode_310_Datasheet.pdf

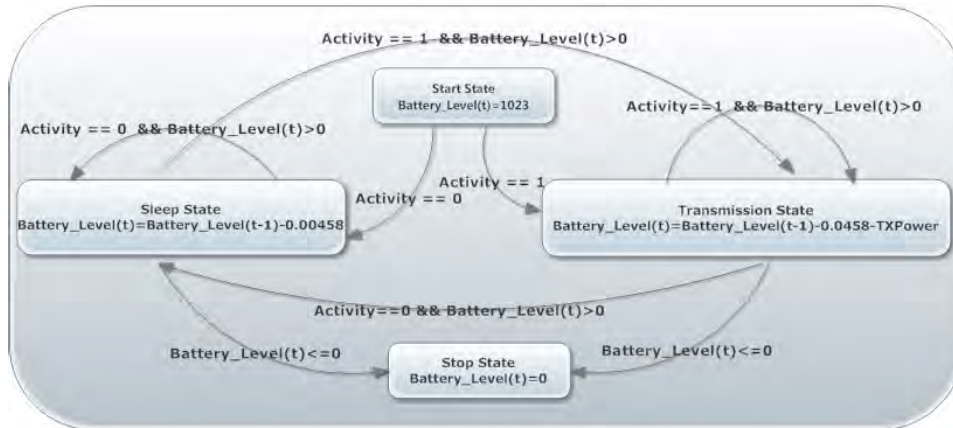

FIGURE 5. State diagram of battery management.

310 transceiver is 110 mAh with maximum P_{TX} (15 dBm), and 70 mAh with minimum P_{TX} .

A first set of simulations were executed to investigate the proper configuration of the FLCs, as detailed in Section V-A and V-B. Then, other simulations were carried out to prove the effectiveness of the proposed approach, as described in Section V-C.

A. EVALUATION OF THE MEMBERSHIP FUNCTIONS

The shape of the membership functions may influence how the FLCs dynamically adapt to the network performance. A particular attention is paid to the industrial scenario, where a good trade-off between energy savings and timeliness of data transmission is required. The most common shapes of the membership function are triangular, trapezoidal and Gaussian. All their combinations for the input and output parameters of the two FLCs were compared, with both the IEEE 802.15.4 and WirelessHART protocols. As an example, Table 3 reports the lifetime of a node battery with the IEEE 802.15.4 standard when its sleeping time is adjusted by FLC₁. The choice of the triangular membership functions for input and output parameters of FLC₁ (shown in the first row of Table 3) guarantees a lifetime close to the maximum value (highlighted in bold font), so it is preferred for its lower computational overhead. The impact of the membership functions on the battery consumption is slightly appreciable, as the relative change of any value reported in Table 3 with respect to the minimum value (which is marked in bold) does not exceed 0.3%. In particular, the relative change between the battery lifetime obtained with the triangular membership functions and the minimum value is equal to 0.28%. Similar considerations can be made by evaluating the shape of the membership functions of FLC₂, also with the WirelessHART protocol, so the triangular membership functions are adopted also in these cases. The combination of triangular membership functions is preferred also because it seems suitable to model a performance degradation that falls dramatically to zero as the system deviates from the expected behavior

TABLE 3. Lifetime of a node according to shape of membership functions of FLC₁. The maximum and minimum values are marked in bold.

Antecedent (Th/Wl)	Antecedent (battery level)	Consequent (sleeping time)	Battery lifetime (seconds)
Triangular	Triangular	Triangular	165060
Triangular	Triangular	Trapezoidal	164980
Triangular	Triangular	Gaussian	164950
Triangular	Trapezoidal	Triangular	165080
Triangular	Trapezoidal	Trapezoidal	165030
Triangular	Trapezoidal	Gaussian	165080
Triangular	Gaussian	Triangular	165020
Triangular	Gaussian	Trapezoidal	164970
Triangular	Gaussian	Gaussian	164990
Trapezoidal	Triangular	Triangular	164710
Trapezoidal	Triangular	Trapezoidal	164650
Trapezoidal	Triangular	Gaussian	164900
Trapezoidal	Trapezoidal	Triangular	164780
Trapezoidal	Trapezoidal	Trapezoidal	164730
Trapezoidal	Trapezoidal	Gaussian	164920
Trapezoidal	Gaussian	Triangular	164650
Trapezoidal	Gaussian	Trapezoidal	164600
Trapezoidal	Gaussian	Gaussian	164840
Gaussian	Triangular	Triangular	165020
Gaussian	Triangular	Trapezoidal	164950
Gaussian	Triangular	Gaussian	165030
Gaussian	Trapezoidal	Triangular	165110
Gaussian	Trapezoidal	Trapezoidal	165060
Gaussian	Trapezoidal	Gaussian	165040
Gaussian	Gaussian	Triangular	164990
Gaussian	Gaussian	Trapezoidal	164910
Gaussian	Gaussian	Gaussian	164960

(i.e., correct sending of packets within the deadline). This choice appears the most appropriate to represent the soft real-time constraints typical of an industrial wireless network, where a performance degradation like some deadline misses can be tolerated only around the deadline itself. A Gaussian or trapezoidal membership function may not allow to model this sudden degradation in an industrial scenario, for example when the package reaches its destination beyond the deadline.

B. EVALUATION OF THE INFERENCE RULES

In order to choose the set of inference rules, the following strategies have been defined and compared:

TABLE 4. Comparison of sets of inference rules for FLC₁. Values are collected after 30 hours of simulations.

Set of rules	Battery level	Deadline miss ratio
deadline-aware	14.3%	8.6%
battery-aware	45.0%	22.7%
compromise	38.2%	17.1%

- 1) deadline-aware rules: the satisfaction of the constraint of real-time data transmission prevails over the energy savings. This means that, for FLC₁, a high, medium or low value of T_h/W_l implies a high, medium or low value of the sleeping time, respectively. Similarly, for FLC₂, a high, medium or low value of the link quality implies a low, medium or high value of the transmission power, respectively.
- 2) battery-aware rules: the behavior of the FLCs is oriented towards energy savings. A low, medium or high value of the battery level implies a high, medium or low value of the sleeping time for FLC₁, and a low, medium or high value of the transmission power for FLC₂.
- 3) compromise rules: the performance degradation (in terms of T_h/W_l or link quality) is somehow balanced with the energy consumption. These rules are listed in Table 1 for FLC₁ and in Table 2 for FLC₂.

In order to compare the performance of the three sets of inference rules, two groups of simulations were performed: either the first or the second FLC was enabled in the Simulink/Matlab model shown in Fig. 4. The values of the parameters were consistent with the datasheets of the IEEE 802.15.4 module, as detailed in Section V. Every simulation was halted when the simulated time arrived at 30 hours, then the final values of battery level and deadline misses were recorded. Table 4 lists the values collected when the first FLC is enabled. Values are expressed in percentage: the battery level is relative to the full charge, whereas the deadline miss is expressed as the ratio between the number of missed packets and the total number of sent packets. It can be noted that by using the first set of inference rules, the deadline miss ratio remains low during the simulation, but the battery is almost discharged after 30 hours. Instead, the other two sets of rules preserve the battery charge at the expense of a higher number of deadline misses. Nevertheless, the deadline miss ratio remains acceptably low with the third set of rules, so this is adopted for evaluating the proposed solution. A similar trend is observed when evaluating the three sets of rules with the second FLC: also in this case the third set of rules achieves the best trade-off between energy consumption and deadline miss ratio.

C. EVALUATION OF THE PROPOSED APPROACH

Four different scenarios are considered in order to evaluate the effectiveness of the proposed approach. The first scenario concerns the standard condition, i.e., without any FLC: in this case, the transmission power is fixed to the highest value, and the sleeping time is equal to the sampling time. In the

second and third scenarios, the transmission power is managed through a P controller [29] and a PID controller [30], respectively. Finally, DSA [15] is exploited in the last scenario to adjust the sampling time of a node; here the sleeping time is set equal to the sampling time. All simulations were carried both in IEEE 802.15.4 and in WirelessHART networks. Each simulation lasted 56 hours.

The results obtained in the IEEE 802.15.4 network are shown in Fig. 6. The proposed approach significantly improves the battery duration: in the standard condition the battery is fully discharged after 36 hours, while using FLCs prolongs the battery duration to 45 hours, with a 25% improvement. Although the other state-of-the-art approaches bring benefits, they do not reach the performance of the proposed one based on FLCs: the battery level drops to zero after about 38 hours both with the P and PID controller, and after 43 hours with DSA.

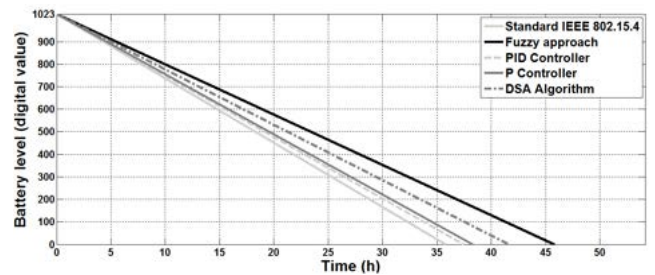

FIGURE 6. Battery consumption in IEEE 802.15.4 scenario.

The results obtained in the WirelessHART network are shown in Fig. 7. The proposed approach reaches the best performance also in this case. In the standard condition, the battery is fully discharged after 37 hours, but using the two FLCs the battery duration is extended up to 52 hours: this corresponds to a 40% improvement. As in the previous case, results obtained by the other approaches stand in the middle.

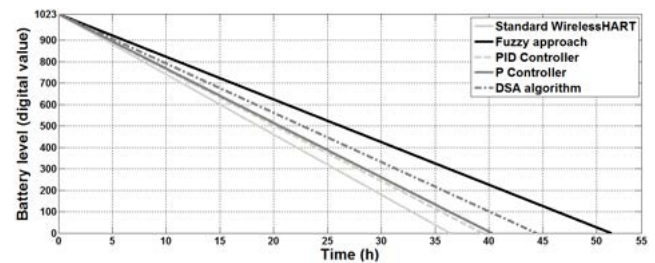

FIGURE 7. Battery consumption in WirelessHART scenario.

VI. TESTBED RESULTS

Two real testbed scenarios have been implemented in order to validate the simulation results. The considered topology is a star network with one central network controller and 4 devices that communicate directly with it. Despite its simple architecture, the centralized single-hop system is chosen as testbed because it could represent a basic block in more

complex systems. In fact, when a distributed multi-hop WSN is considered, some network controllers are recommended to be inserted in order to limit the network traffic, as discussed in Section IV.

The IEEE 802.15.4 network is composed of four MRF24J40MA devices, one of which is shown in Fig. 8. Fig. 9 shows one of the four Versanode 310 transceivers adopted in the WirelessHART network. The module MRF24J40MA has a current consumption of 130 mA during transmission at maximum P_{TX} , 25 mA in receiving mode and 5 μA in sleep state; the values for the VersaNode 310 transceiver are 110 mA, 21 mA and 40 μA , respectively. The network controller is the PIC24FJ256GB108 device, a 16-bit microcontroller of the PIC24F family. The two FLCs have been implemented in the microcontroller in C language, through the embedded code generator included in Matlab/Simulink.

In both testbeds, the nodes were fully charged up and then their battery life was measured. The tests were repeated by removing the FLCs on the network controller: in this case,

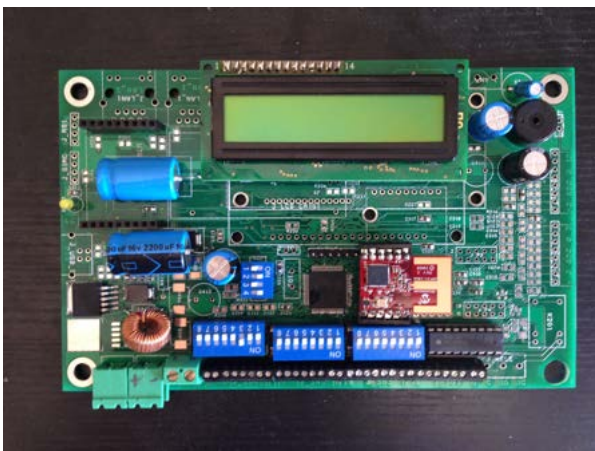

FIGURE 8. Hardware board for the IEEE 802.15.4 network.

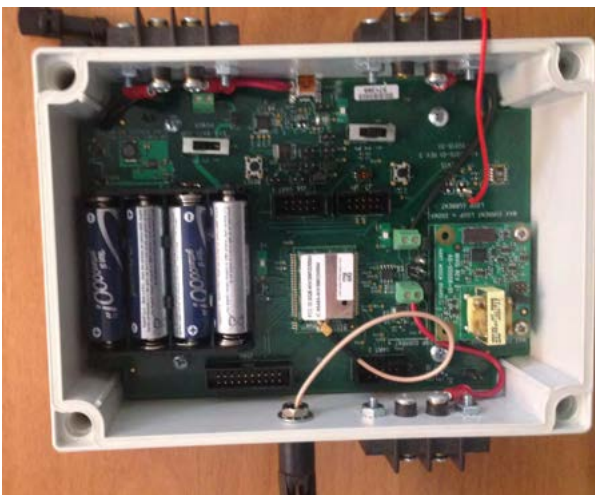

FIGURE 9. Hardware board for the WirelessHART network.

the transmission power and sleeping time of the nodes do not vary. Table 5 reports the average values of the node battery lifetime measured during the tests. The benefits due to the FLCs are manifest: the battery lifetime increases considerably in both scenarios. In the IEEE 802.15.4 network, the nodes run out of energy after 36 hours, but by means of the proposed fuzzy logic-based approach, their lifetime can be extended up to 43 hours, with a 26% increase. The improvement is even more striking in the WirelessHART network: the battery lifetime goes from 37 hours, without FLCs, up to 52 hours, with FLCs, with a 40% increment. It should be noted that the average battery lifetime is longer in the WirelessHART network than in the IEEE802.15.4 network due to the different power consumption of the transceivers used in the testbeds.

The average battery lifetime measured in the testbed is compliant with simulated values, as can be noted in Table 5. The similarity among data confirms the validity of both the simulation model and the real implementation. In general, the performance measured in the testbed is lower than the simulated value. In fact, in the testbed every device consumes some additional power while receiving data, because it is not aware of the instant transmission of the other devices. This power is not considered in the simulations: as shown in Fig. 4, only a basic block composed of a single node and the FLCs is simulated, without any interaction with neighboring nodes in the network. The advantage of simulating only a single node is that the simulator can be validated more easily and the results are more accurate. On the contrary, simulating the behavior of a whole network requires modeling features such as packet transmission and node interference, which unavoidably affect the accuracy of the simulation.

TABLE 5. Battery lifetime computed in simulations and measured in testbed.

	simulations	testbed
IEEE 802.15.4 with FLCs	45 hours	43 hours
IEEE 802.15.4 without FLCs	36 hours	34 hours
WirelessHART with FLC	52 hours	49 hours
WirelessHART without FLCs	37 hours	35 hours

A. IMPACT ON NETWORK TRAFFIC

The network controller exchanges data packets with the nodes in the WSN in order to set their optimal configuration. The network controller receives information to be processed by the FLCs, and it sends to every node the values of sleeping time and transmission power computed by the FLCs. The typical data packet exchanged among the network controller and the nodes is composed of:

- a header field, which measures 8 bytes and determines the specific command sent by the device,
- the sender ID (IDTX), which measures 3 bytes,
- the receiver ID (IDRX), which measures 3 bytes,
- the data field, whose size varies from 0 to 10 bytes,
- two termination characters (end), which occupy 2 bytes.

Header	IDTX	IDRX	data	end	
AT*NCCOM	999	001	05	20	1310
AT*FDCOM	001	999	0855	20.5	1310

FIGURE 10. Example of packets sent by the network controller (above) and by the device (below).

Two commands can be indicated in the header field: AT*NCCOM and AT*FDCOM. The former identifies a message from the network controller to the device, while the latter is sent from the device to the network controller. An example is given in Fig. 10: first a network controller, with ID 999, sends the values of sleeping time (5 s) and P_{TX} (−20 dBm) to a device with ID 001. This device replies with a packet containing the battery level (a digital value represented in 4 bytes) and collected data (the temperature, equal to 20.5 °C).

Despite two additional control packets, the proposed approach is able to reduce the number of transmitted data. In fact, without network controllers, the device would send data every second (as this is the sampling time). In this case, each device sends 129,600 data packets over the network during 36 hours of operation, for a total of 518,400 packets exchanged. Instead, when the FLCs regulate their sleeping time, the number of data sent by each device decreases significantly. It is experimentally measured that 273,385 packets are sent by the nodes during 36 hours. In addition, 2,948 packets are sent by the network controller: this amount is limited and it depends mainly on the variation of the link quality and battery level of each node. Overall, in the realized testbed the number of transmitted packets is reduced by 46% with respect to the standard case.

VII. CONCLUSION

This paper presented an approach based on two fuzzy logic controllers to prolong the lifetime of a WSN. The main advantage of this control scheme is the possibility of independently regulating two parameters that affect the energy consumption of the nodes: sleeping time and transmission power. The first fuzzy logic controller evaluates the throughput to workload ratio and remaining battery energy in order to adjust the sleeping time of the devices, while the second controller adjusts the transmission power according to battery energy and link quality.

The benefits have been evaluated first with Matlab simulations and then with real implementations. Two standards for managing multiple accesses to the wireless channel are distinctly applied in the evaluation: IEEE 802.15.4 and WirelessHART. The simulations reveal that in a IEEE 802.15.4 network the node lifetime is about 36 hours, but it can be extended to 48 hours by means of the fuzzy logic controllers, with a 33% improvement. The improvement in a WirelessHART network is even higher and reaches about 40%. The results obtained in real implementations confirm

the simulated model, although the measured battery duration is generally lower than the simulated one due to power consumed by nodes during reception.

REFERENCES

- [1] Z. Iqbal, K. Kim, and H.-N. Lee, "A cooperative wireless sensor network for indoor industrial monitoring," *IEEE Trans. Ind. Informat.*, vol. 13, no. 2, pp. 482–491, Apr. 2017.
- [2] H. Harb and A. Makhoul, "Energy-efficient sensor data collection approach for industrial process monitoring," *IEEE Trans. Ind. Informat.*, vol. 14, no. 2, pp. 661–672, Feb. 2018.
- [3] H. Natarajan, S. K. Nagpal, and S. Selvaraj, "Impact of rate of recurrent communication of sensor node on network lifetime in a wireless sensor network," *IET Sci., Meas. Technol.*, vol. 11, no. 4, pp. 473–479, Jun. 2017.
- [4] J. Yan, M. Zhou, and Z. Ding, "Recent advances in energy-efficient routing protocols for wireless sensor networks: A review," *IEEE Access*, vol. 4, pp. 5673–5686, Aug. 2016.
- [5] J. Qiao and X. Zhang, "Polar coordinate-based energy-efficient-chain routing in wireless sensor networks using random projection," *IEEE Access*, vol. 6, pp. 21275–21286, Apr. 2018.
- [6] L. Xu, R. Collier, and G. M. P. O'Hare, "A survey of clustering techniques in WSNs and consideration of the challenges of applying such to 5G IoT scenarios," *IEEE Internet Things J.*, vol. 4, no. 5, pp. 1229–1249, Oct. 2017.
- [7] W. Zhang, L. H. G. Li, and L. Zhang, "E2HRC: An energy-efficient heterogeneous ring clustering routing protocol for wireless sensor networks," *IEEE Access*, vol. 5, pp. 1702–1713, 2017.
- [8] H. Bagci and A. Yazici, "An energy aware fuzzy approach to unequal clustering in wireless sensor networks," *Appl. Soft Comput.*, vol. 13, no. 4, pp. 1741–1749, Apr. 2013.
- [9] R. Logambigai and A. Kannan, "Fuzzy logic based unequal clustering for wireless sensor networks," *Wireless Netw.*, vol. 22, no. 3, pp. 945–957, Apr. 2016.
- [10] P. Bartolomeu, M. Alam, J. Ferreira, and J. Fonseca, "Survey on low power real-time wireless MAC protocols," *J. Netw. Comput. Appl.*, vol. 75, pp. 293–316, Nov. 2016.
- [11] Q. Ren and Q. Liang, "An energy-efficient MAC protocol for wireless sensor networks," in *Proc. IEEE Global Telecommun. Conf. (GLOBECOM)*, vol. 1, Nov. 2005, pp. 157–161.
- [12] *IEEE Standard for Local and Metropolitan Area Networks—Part 15.4: Low-Rate Wireless Personal Area Networks (LR-WPANs)*, IEEE Standard 802.15.4-2011 (Revision IEEE Standard 802.15.4-2006), Sep. 2011, pp. 1–314.
- [13] *Industrial Communication Networks—Wireless Communication Network and Communication Profiles*, Standard IEC 62591, Feb. 2016, pp. 1–87.
- [14] F. Xia, W. Zhao, Y. Sun, and Y.-C. Tian, "Fuzzy logic control based QoS management in wireless sensor/actuator networks," *Sensors*, vol. 7, no. 12, pp. 3179–3191, 2007.
- [15] M. Collotta, G. Pau, V. M. Salerno, and G. Scatà, "A fuzzy based algorithm to manage power consumption in industrial wireless sensor networks," in *Proc. 9th IEEE Int. Conf. Ind. Inform.*, Jul. 2011, pp. 151–156.
- [16] Y. Zhang, S. He, J. Chen, Y. Sun, and X. S. Shen, "Distributed sampling rate control for rechargeable sensor nodes with limited battery capacity," *IEEE Trans. Wireless Commun.*, vol. 12, no. 6, pp. 3096–3106, Jun. 2013.
- [17] T. Jiang, P. Wu, B. Shen, and K. Kwak, "A novel fuzzy algorithm for power control of wireless sensor nodes," in *Proc. 9th Int. Symp. Commun. Inf. Technol. (ISCIT)*, Sep. 2009, pp. 64–68.
- [18] A. Lakshmi, S. Manisekaran, and R. Venkatesan, "Fuzzified dynamic power control algorithm for wireless sensor networks," *Int. J. Eng. Sci. Technol.*, vol. 3, no. 4, pp. 3023–3028, Apr. 2011.
- [19] S. Ramakrishnan and T. Thyagarajan, "Energy efficient medium access control for wireless sensor networks," *Int. J. Comput. Sci. Netw. Secur.*, vol. 9, no. 6, pp. 273–279, Jun. 2009.
- [20] J. Zhang, J. Chen, and Y. Sun, "Transmission power adjustment of wireless sensor networks using fuzzy control algorithm," *Wireless Commun. Mobile Comput.*, vol. 9, no. 6, pp. 805–818, 2009.
- [21] R. Yousaf, R. Ahmad, W. Ahmed, and A. Haseeb, "Fuzzy power allocation for opportunistic relay in energy harvesting wireless sensor networks," *IEEE Access*, vol. 5, pp. 17165–17176, Aug. 2017.
- [22] Z. Zhang, Z. Hao, S. Zeadally, J. Zhang, B. Han, and H. C. Chao, "Multiple attributes decision fusion for wireless sensor networks based on intuitionistic fuzzy set," *IEEE Access*, vol. 5, pp. 12798–12809, Jul. 2017.

- [23] M. Collotta, G. Scatà, S. Tirrito, R. Ferrero, and M. Rebaudengo, "A parallel fuzzy scheme to improve power consumption management in wireless sensor networks," in *Proc. 19th IEEE Int. Conf. Emerg. Technol. Factory Automat. (ETFA)*, Sep. 2014, pp. 1–4.
- [24] T. Lennvall, S. Svensson, and F. Hekland, "A comparison of WirelessHART and ZigBee for industrial applications," in *Proc. IEEE Int. Workshop Factory Commun. Syst. (WFCS)*, May 2008, pp. 85–88.
- [25] W. Ye, J. Heidemann, and D. Estrin, "Medium access control with coordinated adaptive sleeping for wireless sensor networks," *IEEE/ACM Trans. Netw.*, vol. 12, no. 3, pp. 493–506, Jun. 2004.
- [26] M. A. Hyder, M. M. Kamal, M. J. Alam, and A. K. M. Z. Satter, "Fuzzy logic based snooze schema for wireless sensor network MAC protocol," in *Proc. 14th Int. Conf. Comput. Inf. Technol. (ICCIT)*, Dec. 2011, pp. 145–150.
- [27] C. Cano, B. Bellalta, A. Sfaïropoulou, and M. Oliver, "Low energy operation in WSNs: A survey of preamble sampling MAC protocols," *Comput. Netw.*, vol. 55, no. 15, pp. 3351–3363, Oct. 2011.
- [28] E. R. Sanchez, B. Montrucchio, L. M. Murillo, and M. Rebaudengo, "Adaptive fuzzy-MAC for power reduction in wireless sensor networks," in *Proc. 4th IFIP Int. Conf. New Technol., Mobility Secur. (NTMS)*, Feb. 2011, pp. 1–5.
- [29] G. von Zengen, F. Büsching, W.-B. Pöttner, and L. Wolf, "Transmission power control for interference minimization in WSNs," in *Proc. Int. Wireless Commun. Mobile Comput. Conf. (IWCMC)*, Aug. 2014, pp. 74–79.
- [30] X. Shen, J. Ma, and G. Dai, "PID-based power adjustment for topology control in wireless sensor networks," in *Proc. IET Conf. Wireless, Mobile Sensor Netw. (CCWMSN)*, Dec. 2007, pp. 632–635.
- [31] M. Collotta, L. L. Bello, and E. Toscano, "A proposal towards flexible wireless communication in factory automation based on the IEEE 802.15.4 protocol," in *Proc. 14th IEEE Conf. Emerg. Technol. Factory Autom. (ETFA)*, Sep. 2009, pp. 1–4.



RENATO FERRERO received the M.S. degree in computer engineering and the Ph.D. degree in computer engineering from the Politecnico di Torino, Italy, in 2004 and 2012, respectively, where he is currently an Assistant Professor with the Dipartimento di Automatica e Informatica. His research interests include ubiquitous computing, wireless sensor networks, and RFID systems.



responsible of the Computer Engineering and Networks Laboratory. His research activity is mainly focused on the study of innovative solutions and approaches in expert systems and networks, focused on real-time and secure application.

MARIO COLLOTTA received the M.S. degree in telecommunications engineering and the Ph.D. degree in computer and telecommunications engineering from the University of Catania. He received confirmation by the National Advisory Commission in order to become an Associate Professor, in 2017, and Full Professor, in 2018. Since 2010, he has been an Assistant Professor (SSD ING-INF/05) of computer engineering with the Kore University of Enna. He is scientific



MAURIZIO REBAUDENGO received the M.S. degree in electronics and the Ph.D. degree in computer engineering from the Politecnico di Torino, Torino, Italy, in 1991 and 1995, respectively, where he is currently a Full Professor with the Dipartimento di Automatica e Informatica. His research interests include ubiquitous computing, the IoT platforms, and dependability analysis of computer-based systems.

• • •