

Development and assessment of a solar home system to cover cooking and lighting needs in developing regions as a better alternative for existing practices

*Original*

Development and assessment of a solar home system to cover cooking and lighting needs in developing regions as a better alternative for existing practices / Zubi, Ghassan; Spertino, Filippo; Carvalho, Monica; Adhikari, Rajendra S.; Khatib, Tamer. - In: SOLAR ENERGY. - ISSN 0038-092X. - ELETTRONICO. - 155:(2017), pp. 7-17.  
[10.1016/j.solener.2017.05.077]

*Availability:*

This version is available at: 11583/2679997 since: 2020-01-29T12:41:30Z

*Publisher:*

Elsevier Ltd

*Published*

DOI:10.1016/j.solener.2017.05.077

*Terms of use:*

This article is made available under terms and conditions as specified in the corresponding bibliographic description in the repository

*Publisher copyright*

(Article begins on next page)

# Development and assessment of a solar home system to cover cooking and lighting needs in developing regions as a better alternative for existing practices

Ghassan Zubi<sup>a,b,\*</sup>, Filippo Spertino<sup>c</sup>, Monica Carvalho<sup>d</sup>, Rajendra S. Adhikari<sup>e</sup>, Tamer Khatib<sup>f</sup>

<sup>a</sup> Department for Management of Science and Technology Development, Ton Duc Thang University, Ho Chi Minh City, Viet Nam

<sup>b</sup> Faculty of Electrical & Electronics Engineering, Ton Duc Thang University, Ho Chi Minh City, Viet Nam

<sup>c</sup> Politecnico di Torino, Energy Department, Torino, Italy

<sup>d</sup> Department of Renewable Energy Engineering, Center of Alternative and Renewable Energy, Federal University of Paraíba, João Pessoa, Paraíba, Brazil

<sup>e</sup> Politecnico di Milano, Dept. Architecture, Built Environment and Construction Engineering, Milano, Italy

<sup>f</sup> Energy Engineering and Environment Department, An-Najah National University, Nablus, Palestine

---

## A B S T R A C T

An estimated 1.2 billion people around the world don't have access to electricity, while many more suffer from supply that is of poor quality. Domestic energy poverty is most severe in the rural areas of South Asia, South East Asia and Sub-Saharan Africa. Basic energy needs, such as cooking and lighting, are covered using traditional biomass and fossil fuels. These are consumed inefficiently in fire stoves and flame lamps. This situation hampers economic growth and social development and implies severe stress on resources and the environment. Photovoltaics could play a major role in overcoming domestic energy poverty, especially as most of the affected regions are within the Earth's Sunbelt. This paper provides such a solution in the form of a solar home system with lithium-ion battery in combination with an energy efficient multicooker and LED lamps to cover the needs for cooking and lighting for one family. A solar home system layout is provided and assessed in terms of its cost and benefits in contrast with the existing practices for cooking and lighting in developing regions. Thereby, evolutionary aspects are taken into account to capture the incremental cost advantage of the solar home system technology over time, and with that support the idea of projecting large-scale implementation in developing regions.

---

### Keywords:

Energy poverty  
Solar home system  
Lithium-ion battery  
Efficient household electric appliances

## 1. Introduction

Around 16% of the world's population don't have access to electricity, most of them living in rural areas in South Asia, Southeast Asia and Sub-Saharan Africa. Many more suffer from supply that

is of poor quality. As a consequence, 38% of the world's population lack clean cooking facilities. This results in high reliance in the developing world on traditional biomass and fossil fuels to cover basic domestic energy needs, such as cooking and lighting. This situation implies a poverty trap and development barrier, and goes together with severe stress on resources and the environment (UNDP, 2011, 2013, 2014). Safety is a concern when it comes to the domestic storage and use of fuels, such as kerosene (Lam et al., 2012). Furthermore, indoor fires have severe negative health effects (WHO, 2011). There is also a striking relation between domestic energy poverty and gender inequality, as well as a major effect on the life of children, as they often have limited resources and limiting conditions to perform their educational tasks. Overcoming energy poverty in developing regions is a global challenge, and should be perceived as an integral part of our common duty to promote human development and equality while conserving our planet.

---

*Abbreviations:* AC, Alternating Current; BaU, Business as Usual; BMS, Battery Management System; CRI, Color Rendering Index; C-Si, Crystalline Silicon; DC, Direct Current; EV, Electric Vehicle; iHOGA, improved Hybrid Optimization by Genetic Algorithms; LCO, Lithium Cobalt Oxide (LiCoO<sub>2</sub>); LCoE, Levelized Cost of Electricity; LED, Light Emitting Diode; LFP, lithium iron phosphate (LiFePO<sub>4</sub>); Li-ion, Lithium-ion; LMO, Lithium Manganese Oxide; LPG, Liquefied Petroleum Gas; LTO, Lithium Titanate (Li<sub>4</sub>Ti<sub>5</sub>O<sub>12</sub>); NCA, Lithium Nickel Cobalt Aluminium Oxide; NMC, Lithium Nickel Manganese Cobalt Oxide; NPC, Net Present Cost; PV, Photovoltaics; SHS, Solar Home System; SOC, State of Charge.

\* Corresponding author at: Department for Management of Science and Technology Development, Ton Duc Thang University, Ho Chi Minh City, Viet Nam.

*E-mail addresses:* [ghassan.zubi@tdt.edu.vn](mailto:ghassan.zubi@tdt.edu.vn) (G. Zubi), [filippo.spertino@polito.it](mailto:filippo.spertino@polito.it) (F. Spertino), [monica@cear.ufpb.br](mailto:monica@cear.ufpb.br) (M. Carvalho), [rajendra.adhikari@polimi.it](mailto:rajendra.adhikari@polimi.it) (R.S. Adhikari), [t.khatib@najah.edu](mailto:t.khatib@najah.edu) (T. Khatib).

Several solutions have been followed so far to tackle domestic energy poverty in developing regions. Among others, solar-thermal cooking systems, such as the solar-box and parabolic cooker, have been developed and implemented. These systems are simple, affordable and don't have practically any environmental impact. Nevertheless, they have found little success until today, basically as they provide limited added value. The solar-box, for instance, is very easy to build and is made of cheap materials, but cooking is very slow and the maximum reachable temperature is relatively low, which limits the cooking options. More details on the solar-box are available in the references (Raji Reddy and Narasimha Rao, 2007; Kumar et al., 2010). On the other hand, concentrating solar cookers, like the parabolic cooker, are more powerful, but the cooking rate cannot be controlled and it's potentially hazardous due to the focusing of the sun beam. The cooking time is also limited to clear sky periods. More details on parabolic cookers are available in the references (Bardan et al., 2010; Abu-Malouh et al., 2011). In another approach, a hybrid solar cooking system has been suggested (Prasanna and Umanand, 2011). In this case a solar thermal collector heats a fluid, which is transferred to the kitchen and supplements a conventional LPG (Liquified Petroleum Gas) source. This system has a relatively low solar fraction, basically due to the temperature requirements of fast cooking, and is therefore not much cleaner than a pure LPG stove, while bringing substantial system complexity. Altogether, solar-thermal cooking systems can alleviate energy poverty, but they have limited potential to revolutionize development in affected regions. In the broader context, research should gravitate towards access to electricity with focus on a rapid transformation that gives priority to sustainable growth under minimal environmental impact. PV (Photovoltaics) is especially an interesting solution here as most of the global population that live under energy poverty are in the Sunbelt Countries. Accordingly, the focus of this paper is on SHS (Solar Home Systems).

A key factor in the successful implementation of SHS in developing regions, i.e. under severe economic constraints, is to limit their application to very high added value appliances and to properly exploit innovations, especially in energy efficiency and cost reductions. High added value is achieved with moderate cost high efficiency electric appliances that make a difference in time spent for domestic tasks, in the preservation of a healthy living environment and provide the required conditions for children to perform their educational tasks. The two basic appliances within this context are a multicooker and LED (Light Emitting Diode) lamps. Furthermore, a SHS allows for the recharge of portable electronics such as a mobile phone. The battery is a critical component in the SHS; the choice of battery in this paper is Li-ion (Lithium-ion). This differentiates this work from many others on SHS, where it is opted for lead-acid batteries, basically due to their low cost advantage. Nevertheless, lead-acid batteries are less reliable, have higher maintenance requirement and a shorter lifetime; all these are critical factors when it comes to a SHS application in remote developing regions where technical support is not easily available. Li-ion batteries have also a substantial energy density advantage over the lead-acid chemistry, which makes them relatively light and compact and storable indoors, with all the advantages this implies in terms of lifetime and its predictability. The key components of the SHS of this paper are: the PV generator, Li-ion battery, multicooker, LED lamps and a U-socket for the recharge of portable electronics.

There is a big number of scientific publications on stand-alone PV systems, both pure solar and hybrid systems (mostly PV with diesel generator and/or wind turbines), that tackle electrification in developing regions. These focus on the application, simulation, engineering, monitoring and performance in different countries and locations. For instance, Ranaboldo et al. present and analyse

a design for a community electrification project in Nicaragua based on a PV-Wind system (Ranaboldo et al., 2015). Ibrahim et al. detail a demonstration project of a PV-based micro-grid in a rural area in Bangladesh (Ibrahim et al., 2002). A study on the potential of applying renewable energy sources for rural electrification in Malaysia with focus on the poorest states is presented by Borhanazad et al. (2013). Adaramola et al. focus on remote communities in Ghana and provide an economic analysis for a power supply system consisting of a PV generator and wind turbine with diesel backup (Adaramola et al., 2014). Ahlborg & Hammer present a study on the drivers and barriers for the implementation of off-grid renewable energy for rural electrification in Tanzania and Mozambique (Ahlborg and Hammar, 2014). Suresh Kumar & Manoharan analyse the economic feasibility of hybrid off-grid renewable energy for remote areas in the state of Tamil Nadu in India (Suresh Kumar and Manoharan, 2014). Bekele & Palm provide a feasibility study for hybrid solar-wind power supply systems for off-grid applications in Ethiopia (Bekele and Palm, 2010). Dufo-López et al. present a techno-economic assessment of an off-grid PV-powered community kitchen for developing regions (Dufo-López et al., 2012). Zubi et al. perform a techno-economic assessment of an off-grid PV system to provide electricity for basic domestic needs (Zubi et al., 2016a). The same authors present in another article a detailed comparison between kerosene lamps and a SHS powering LED lamps (Zubi et al., 2016b). They concluded that, on a lumens-based comparison, a SHS-LED solution is roughly 15 times cheaper than Kerosene. While stand-alone PV systems supply typically households and water pumping systems for irrigations, other applications, as for example the power supply of off-grid hospitals, are also important. For instance, Dufo-López et al. present a study on the PV power supply of off-grid healthcare facilities, providing a system optimization method using Monte Carlo simulation (Dufo-López et al., 2016). Al-Karaghoul & Kazmerski provide a PV solution for a health clinic in a rural area in southern Iraq supported with system optimisation and cost assessment performed with HOMER software (Al-Karaghoul and Kazmerski, 2010). There are also several review articles on off-grid PV. For instance Akikur et al. present a comparative study for hybrid PV systems for powering single houses and small communities for various locations throughout the world (Akikur et al., 2013). Mohammed et al. review several substantial issues of hybrid renewable energy systems for off-grid power supply, including drivers and benefits, design and implementation, as well as the simulation and optimization tools (Mohammed et al., 2014). Bernal-Agustín & Dufo-López review the current simulation and optimization techniques for stand-alone hybrid systems (Bernal-Agustín and Dufo-López, 2009). A similar, but more recent work is available by Sinha and Chandel (2014).

Based on the energy ladder hypothesis, the most common practice to alleviate domestic energy poverty in developing regions is currently the subsidy of kerosene and LPG to encourage the switching from traditional biomass to these fossil fuels. This measure is easy to implement for governments, but it's also very costly; India alone spends more than 5 billion US\$ per annum in such subsidies. Thereby, the achievements through such budgets are far from satisfactory. Fossil fuel subsidies have often led to fuel stacking rather than complete fuel switching; it's often so that the consumer opts for the alternative fuel as long as it's cheap, i.e. subsidized. This implies in real terms a subsidy addiction that can only aggravate over time with the general upwards tendency of crude oil prices. This current path has definitely a grim long-term perspective, both environmentally as economically. On the other hand, this paper defends that a SHS in combination with state of the art batteries and electric appliances is a better solution, both in terms of achievable results in overcoming energy poverty and the budget this

requires. Thereby, this work is not only about an immediate solution for specific countries and its short-term impact, but rather about the long-term potential of SHS to help overcome domestic energy poverty at a global scale. This has to be emphasized through the learning curve of PV modules and batteries and their ever going technological advances, which contrasts with a generally incremental fossil fuel prices. Identifying and quantifying this potential today could incentive projections for large scale implementation of SHS. This specific task is performed within this paper, which should be understood as a convincing study that speaks for the development, promotion and implementation of SHS to help overcome global energy poverty.

Accordingly, in the first step, this paper carries out a SHS simulation and optimisation for different locations using the software iHOGA (improved Hybrid Optimization by Genetic Algorithms). The outcome is used to elaborate a standard SHS that can be implemented widely within the Earth's Sunbelt. This representative layout is used for further assessment of the technology. Based on a techno-economic assessment of all mentioned SHS components and the iHOGA simulation, the SHS NPC (Net Present Cost) for its entire lifetime is calculated. Under consideration of the learning curve and the foreseeable technological advances, an evolutionary assessment of the SHS technology is performed, most specifically considering the time-frame 2020–2035 in five year steps. This is contrasted with a representative scenario for the current practices for cooking and lighting under energy poverty, which is in this paper based on kerosene.

The software iHOGA has been developed at the Department of Electrical Engineering of the University of Zaragoza, Spain (iHOGA, 2017). It is a C++ based tool for the simulation and optimization of hybrid renewable energy systems both off-grid and grid-connected. iHOGA has been used in several scientific publications. For instance it has been implemented to perform a multi-objective optimization for minimizing cost and life cycle emissions of a hybrid standalone system that combines a PV generator, wind turbine, battery bank and a diesel generator (Dufo-López et al., 2011). In another study it was used for the sizing of off-grid renewable energy systems for drip irrigation of Mediterranean crops with focus on the economic optimization by using genetic algorithms (Carroquino et al., 2015).

After this introduction, Section 2 provides an overview on the electric appliances of the SHS, i.e. the multicooker and LED lamps, which allows to conclude on a representative power demand curve for the SHS simulation in iHOGA. Section 3 provides an overview about Li-ion batteries in terms of their state of the art and development tendencies within the context of their relevance for this paper. This information supports the conclusion regarding which Li-ion chemistry is most adapted for the SHS application. Furthermore, it justifies the inputs used in the iHOGA simulation and optimisation as well as in the SHS economic assessment. Finally, this section provides the optimisation results regarding the SHS battery size. In this same line, section 4 gives a brief overview on PV technology and calculates the PV generator size, which is done for different geographic locations to provide contrast and understanding of the resulting layout variations and their impact on the SHS cost. For further assessment, a standard SHS solution has been elaborated, i.e. with one battery and PV generator size, that can be widely used within the Earth's Sunbelt. This representative SHS layout is very useful for the purpose of simplifying an evolutionary assessment of the technology and to provide long-term comparisons with existing practices for cooking and lighting in developing regions. This comparison is performed within Section 5 for the time-frame 2020–2035 in five year steps with focus on the NPC. Finally, section 6 summarizes the conclusions of the paper.

## 2. Electric appliances

The focus of this research is on a SHS that covers the electricity demand for a multicooker and LED lamps. In this section details will be provided on the two electric appliances. This allows to conclude on the power demand curve for the SHS simulation in iHOGA and on the inputs for the economic assessment of the SHS.

A multicooker is an automated electric multipurpose cooking appliance. It includes electronic time and temperature controllers. Some devices have also features to regulate the cooking pressure. The accurate control allows eventually for many cooking functions. There is a big number of capable multicookers on the market for a price under €130, which is relatively cost effective, especially considering that it can substitute several kitchen appliances. This, however, is not the main market driver in developed countries, where such a device is rather purchased for making cooking simple and attention-free. On the other hand, multicookers are currently uncommon in developing regions. For the moment, and due to the lack of demand, there are no DC (Direct Current) multicookers on the market. These, however, are easy to develop from exiting AC (Alternating Current) designs.

Multicookers are generally very energy efficient; the required heat for cooking is generated internally, while the device is very well insulated so that heat losses through conduction are negligible. Some multicookers on the market deviate from this common characteristic, but they are often rated low by users precisely for reaching high temperature at the outside, which is perceived as unsafe. For the common energy efficient design, a device with 3 l capacity (sufficient to cook for 8 adults) has typically a nominal power around 800 W. This is the maximum power; most cooking programs operate below that. A realistic estimate for the average electricity demand is 50 Wh per meal. A multicooker allows to cook lunch and dinner for a family of 6 members with an average daily energy demand of 0.6 kWh. Table 1 provides a list of multicookers available on the market with their main characteristics.

Most multicookers currently on the market have a warranty period of 2 years, which is currently sufficient to comply with the strictest national regulations for home appliances. The component that suffers most is the inner pot, but it's also the easiest to replace. The steam-outlet is also a high stress spot, but should survive long if made of resistant material. Taking into account one inner pot replacement, in practical terms a lifetime of 5 years is realistic for a multicooker of a prominent brand.

LED lamps are most characterized by their high luminous efficacy. Most current commercial LED lamps have a luminous efficacy in the range of 70–100 lm/W (lumens per watt). This implies a substantial efficiency advantage even over fluorescent lamps, which have typically a luminous efficacy around 55 lm/W. The current lab record for LED lamps is 303 lm/W. Such record LEDs have a relatively low CRI (Color Rendering Index) and are therefore not apt for commercialization. This said, the commercial LED lamp technology has still a significant unexploited potential for developing high CRI lamps with a luminous efficacy above 100 lm/W.

Most current commercial LED lamps have a lifespan above 20,000 operation hours, which implies a calendar lifetime over 10 years by an average daily use of 5 h. Thanks to the relatively low operating temperature, the degradation of the LEDs is relatively slow. The most common warranty period for current commercial LED lamps is 3–5 years, while few brands offer warranties in the range of 5–10 years. Durability of LED lamps has also still an unexploited improvement potential, so that lamps with even longer lifespan can be expected in the future.

The purchase cost of a LED lamp on a per lumens basis is higher than other lighting technologies, but still, in terms of total cost, i.e. considering savings in energy and bulb replacements, they are the

**Table 1**  
Commercially available multi cookers.

Device Name	Capacity [L]	Power [W]	Price [€]	Rice	Steam	Pressure cook	Boil	Stew	fry	Roast	Grill	Bake
Gourmia GCR-1700	3	800	140		x			x	x	x	x	x
Gourmia GPC400	3.7	800	90	x	x	x	x	x	x	x		
Instant Pot IP-LUX60	6	1000	90	x	x	x	x	x				
Philips HD3095/87	2.5	800	150	x	x		x	x	x	x		x
T-fal RK705851	2.5	800	120	x	x		x	x	x			x
KitchenAid 5KMC4241	4	700	220	x	x		x	x	x	x		
Vita-Clay VM7900-8	2	600	120	x	x		x	x				
Breville BPR700BSS	6	1100	210	x	x	x	x	x	x			

All multicookers include the functions reheat and keep-warm.

cheapest option. This is already true for the grid-connected use; for off-grid PV systems the total cost advantage is bigger. LED lamps have undergone substantial cost reductions in recent years, reaching currently a typical consumer price around €1 per 100 lumens. Prices around €0.5 per 100 lumens are within the foreseeable range.

In the here mentioned key factors, i.e. energy efficiency, durability and total cost, LED lamps are having an incremental advantage over the other lighting technologies. In terms of light quality, LED lamps perform by far better than fluorescent ones; they have a better CRI and come immediately to full brightness. LED lamps experience a slight decline in luminosity roughly along the 30 min after switch-on due to the temperature increase of the LEDs. The luminosity stabilizes eventually at around 93% the initial value. The full luminosity is recovered once the lamp is switched off and cools down. As the main heat source in the LED lamp is the driver circuit, this setback of luminosity drop during operation is being tackled through the overall improvement in efficiency and with designs that distance and thermally insulate the LEDs from the driver circuit. It's likely that designs with a luminosity drop below 5% will evolve and become eventually the standard. If compared with halogen and incandescent bulbs, LED lamps have generally a lower CRI. This aspect, however, is a central R&D (Research & Development) feature, and it is foreseeable that LED lamps with a CRI above 90 become the standard.

LEDs operate with a DC power of few volts. This condition is provided in the lamp by the driver circuit. For instance, in a 230V AC LED lamp the driver circuit rectifies the current and converts the voltage down to few volts. The driver circuit accounts for most of the energy losses. As DC LED lamps have lower technological requirement on the driver circuit, they have a higher efficiency potential. Nevertheless, DC LED lamps lag behind the AC ones in most key aspects, basically due to their modest market share. DC LED lamps are available with standard DC voltages, mostly 12 V and 24 V.

In this paper we assume the use of 12 V DC LED lamps. For a family in a developing region an installed LED lamp capacity of 60 W is sufficient. The assumed average energy consumption for lighting is roughly 200 Wh/d. The corresponding demand profile is simplified to 40 W along the 5 h after sunset. For the multicooker we assume a 48 V DC device with a nominal power of 700 W. The assumed average energy consumption for cooking is roughly 600 Wh/d. The power demand profile for cooking is simplified to the use of the multicooker twice a day, once at midday and a second time after sunset, in both cases at a power of 600 W and for a duration of 30 min. It is also assumed that the SHS provides electricity for the recharge of portable electronics; a total of 50 Wh/d consumed along 2 night hours. The total daily energy demand is 850 Wh; 600 Wh for cooking, 200 Wh for lighting and 50 Wh for portable electronics. The maximum power that results from connecting all appliances at the same time is around 800 W. The here elaborated simplified demand profile represents the average and is used in the SHS simulation in iHOGA.

### 3. Battery

In this section the SHS battery is determined in terms of technology and nominal capacity. Thereby, extensive details are provided on Li-ion batteries to highlight the different battery chemistries available on the market, amplify their key differences and eventually justify the choice of technology.

Energy storage in off-grid PV is currently dominated by lead-acid batteries. On the medium and long term Li-ion batteries will emerge as very competitive technology (Boucar and Ramchandra, 2015). Such development will be among others strongly driven by their large scale use in the mobility sector. The electrification of road transport counts with strong support from policy makers worldwide as it enhances energy security and implies big potential to reduce greenhouse gas emissions, especially if complemented with emission reductions in power generation. Although, compared to the lead-acid battery, the purchase cost per kWh will remain eventually higher for the Li-ion battery, other advantages will compensate for the difference, including better durability and minor maintenance requirements. This paper opts for the Li-ion battery as these advantages make it the better choice for the here considered SHS application. Further information on lead-acid batteries can be found in the reference (Jung et al. 2015; Reddy, 2011; Pavlov, 2011).

Of all metals available for battery chemistry, lithium has long been considered as the most promising. Apart of being widely available and non-toxic, it is the lightest and most electropositive metal. This fundamental advantage over other chemistries allows lithium-based batteries to have higher potential for energy storage. Nevertheless, lithium is highly reactive, so it's technologically challenging to build safe to use lithium containing battery cells. This challenge has been tackled so far by not using metallic lithium, but instead compounds that are capable of donating lithium ions (Li<sup>+</sup>). The ions are shuttled between two electrodes in a reversible chemical reaction. This chemistry made the commercial breakthrough in 1991. Since then intensive developments and technological diversification have taken place. Li-ion batteries are finding an expanding range of applications which already covers portable electronics, power tools, medical devices, EVs (electric vehicles), telecommunication systems and aerospace applications among others.

The four main components in a Li-ion battery cell are the cathode, anode, electrolyte and separator. The last is a safety element between the cathode and the anode to prevent their direct contact, i.e. short-circuiting, while being permeable for the lithium ions. Current commercial batteries acquire their names from the lithium-ion donor in their cathode as this is the biggest determinant in the cell properties. Several lithium metal oxides are used on the commercial level for this purpose: LCO (lithium cobalt oxide), LMO (lithium manganese oxide), LFP (lithium iron phosphate), NCA (lithium nickel cobalt aluminium oxide) and NMC (lithium nickel manganese cobalt oxide). This variety of materials implies that battery characteristics differ significantly (Nitta



et al., 2015). The current dominant anode material is graphite, although some battery manufacturers have opted for non-graphite anodes such as LTO (lithium titanate,  $\text{Li}_4\text{Ti}_5\text{O}_{12}$ ). The electrolyte is a mixture of lithium salt and organic solvents. Details on the value chain of Li-ion batteries could be found in the reference (Lowe et al., 2010).

The key characteristics of a battery are the specific energy, specific power, durability, safety and cost. The specific energy is defined as the storage capacity in kWh per kg of weight. For the Li-ion battery the specific energy depends much on the used cathode and anode materials. Furthermore, as the active materials in a cell occupy only a fraction of its weight, the cell design also has a relevant impact. For instance, would it be possible to build safe cells without separators, then the specific energy could be increased significantly. Depending on all these factors, current commercial Li-ion batteries cover a wide range of specific energy, roughly from 90 to 250 Wh/kg. Thereby NCA batteries perform best in this aspect, while LFP batteries perform worse. Still, all Li-ion batteries remain far above the modest specific energy of lead-acid batteries, which is typically around 35 Wh/kg. The specific energy is one of the central development criteria in Li-ion batteries for use in EVs as part of the approach to increase the drive range. This has resulted in a general upwards tendency, while there is still a substantial yet to exploit potential.

The power a Li-ion battery could provide depends on many factors including the electrode area, voltage, density of lithium ions, the SEI (Solid Electrolyte Interface) nano-structure, the diffusion coefficient of the electrodes and their conductivity. The specific power is often described within the power to energy (P/E) ratio, i.e. how much power in kW could a battery provide for a kWh of capacity. Li-ion batteries are generally powerful. For instance, batteries used in PHEV (Plug-in Hybrid Electric Vehicle) have normally a P/E ratio above 5. The P/E ratio can be tackled in the cell design by using thinner electrodes to increase their number, which allows to maximize the electrode area.

A key factor of a battery is its durability. Battery degradation takes place in every condition, but in different proportions depending on the use. Tough operating conditions such as low or high operating temperatures, overcharge, deep discharge and high amperage accelerate degradation. In practical terms battery ageing is caused through the loss of cyclable lithium and active electrode materials, and is noticed as capacity fade and loss of power. The loss of cyclable lithium is related to side reactions, while the loss of electrode active materials occurs due to factors such as dissolution, structural degradation and particle isolation among others. A review on the ageing mechanisms of Li-ion batteries and the SOH (State of Health) estimation methods is provided in the reference (Barré et al., 2013). From the point of view of the user the most relevant durability indicator is the cycle life, which is the number of full cycles a battery is able to deliver under standard operating conditions before its key performance metrics, i.e. capacity and power, drop to 80% of their initial value. A detailed understanding of the ageing mechanisms of a battery chemistry paves the way for advanced battery designs with longer cycle life. Thereby, improvements could take place both on the cell and BMS (Battery Management System) level. Li-ion batteries have improved so far notably in terms of durability and there is a widely held expectation that this tendency will continue.

Safety issues of Li-ion batteries are being extensively investigated (Wen et al., 2012). The challenge hereby is not only how to make current batteries safer in an expanding range of applications, but also to improve aspects such as specific energy and specific power without compromising on safety. A serious concern in Li-ion batteries is thermal runaway: If a battery cell is excessively heated, for instance through prolonged overcharge or short circuiting, to the level of decomposing its metal oxide,

the battery could burst into flames through the reaction of freed oxygen with lithium. A detailed review on the thermal runaway of Li-ion batteries is provided in the reference (Wang et al., 2012). Depending on the application, different safety concerns have to be tackled, including factors related to tough operating conditions, such as high or low ambient temperatures, accidents and ageing mechanisms. For instance, the formation of dendrites over time could result in a conductive bridge between an anode and a neighboring cathode, resulting in a short-circuit and eventually thermal runaway. Safety is tackled at three levels: inherent, in the cell design and through the BMS. The first concerns the choice of battery chemistry in the first place. Some battery chemistries are inherently safer than others. This is for instance the case of LFP, especially compared to LCO, as it's thermally much more stable, i.e. decomposes at higher temperature. At the cell level, safety elements and features could be integrated. For instance, the separator has a safety function called "shutdown". If the cell heats up excessively, for example as a consequence of short-circuiting, the separator melts, filling its micro pores and interrupting with that the lithium-ion flow. Finally, the BMS can be very effective in avoiding overcharge and short-circuiting through voltage and current control and with that provide safe operating conditions.

Table 2 summarizes the main characteristics of commercially available Li-ion batteries. LCO is the first Li-ion battery to become commercial in 1991. It is made from a  $\text{LiCoO}_2$  cathode and a graphite ( $\text{C}_6$ ) anode. The high specific energy of roughly 150–190 Wh/kg made LCO batteries a popular choice for portable electronics such as laptops and cell phones. The durability of 500–1000 full cycles translates roughly into a calendar lifetime of few years, which matched relatively well with the lifetime of such innovation intensive devices. The main disadvantage of the LCO battery is its low inherent safety due to the low thermal stability of cobalt-oxide. Thermal runaway could be initiated already at 150 °C. Although the battery found use in aviation, most specifically starting 2011 in the Boeing 787 Dreamliner to provide auxiliary startup and backup power during flight, soon battery failure incidents, including thermal runaway, raised serious concerns, leading to the grounding of all affected airplanes for several months in early 2013. More details on the record of LCO batteries in aviation are available by Williard et al. (2013). Another disadvantage of the LCO battery is its reliance on cobalt.

The LMO battery was first commercialized in 1996. The  $\text{LiMn}_2\text{O}_4$  cathode forms a three dimensional spinel structure which favors the ion flow on the electrode, resulting in low internal resistance. This results in high specific power. LMO cathodes are mostly combined with graphite anodes. LMO batteries have a longer cycle life than LCO, but notably lower specific energy. Due to the higher thermal stability of manganese oxide, the battery is inherently safer; thermal runaway occurs roughly at 250 °C. Furthermore, the battery is cobalt free and relies on abundant and eco-friendly materials. Its common uses include power tools and medical devices. Meanwhile there is a big number of LMO battery manufacturers including AESC, Altairano, Ener1, GS Yuasa, Hitachi, LG Chem, PEVE, Samsung and Sanyo.

The LFP battery has a  $\text{LiFePO}_4$  cathode. Graphite is used mostly as anode material. This battery was first commercialized in 1999 and was soon considered as a promising technology due to its long cycle life, inherent safety and reliance on abundant eco-friendly materials. Current LFP batteries endure up to 2000 full cycles, while industry projections for a longer lifetime are realistic. The battery tolerates operation with a wide SOC (State of Charge) window, roughly from 15 to 100%. The cell displays constant voltage within this range, which implies the best performance. A major setback of this battery is the relatively low specific energy among the Li-ion chemistries. Despite that, the battery has found use in

**Table 2**

Commercial Li-ion batteries (IEA, 2011; Deutsche Bank, 2008; Deutsche Bank, 2009).

Cell (cathode material)	[V]	[Wh/kg]	Full cycles	Advantages (+) and disadvantages (-)
LCO (LiCoO <sub>2</sub> )	3.6	150–190	500–1000	+Specific energy + Maturity -Safety -Durability -Cobalt (toxic, rare, costly)
LMO (LiMn <sub>2</sub> O <sub>4</sub> )	3.8	100–140	1000–1500	+Maturity + Safety + Abundant materials + Eco-friendly -Specific energy -Calendar lifetime
LFP (LiFePO <sub>4</sub> )	3.3	90–140	1000–2000	+Safety + Durability + Performance + Abundant materials + Eco-friendly -Specific energy
NCA (LiNiCoAlO <sub>2</sub> )	3.6	200–250	1000–1500	+Specific energy + Calendar lifetime -Safety -Cobalt
NMC (LiNiMnCoO <sub>2</sub> )	3.6	140–200	1000–2000	+Specific energy + Durability + Maturity -Safety -Cobalt

The anode material is graphite (C<sub>6</sub>) in all cases.

EVs, most specifically in the BYD E6. LFP cell manufacturers include A123 Systems, BYD, GS Yuasa, JCI/Saft, Lishen and Valence.

The NCA battery was commercially introduced in 1999. It is made from a LiNiCoAlO<sub>2</sub> cathode and a graphite anode. Typically, NCA cathodes use a blend of 80% nickel, 15% cobalt and 5% aluminium, hence the reliance on cobalt is relatively moderate compared to LCO batteries. NCA batteries have high specific energy and specific power. They can provide roughly 1000–1500 full cycles. NCA batteries are used in EVs and medical devices, while there are projections for grid-connected use as backup power to provide electricity during peak demand. Most importantly, this battery is used by Tesla Motors in its EVs. Current NCA battery manufacturers include among others AESC, JCI/Saft, Panasonic, PEVE and Samsung. For the moment Tesla is purchasing its battery cells from Panasonic, but the company has ambitious projections to produce its own Li-ion batteries. Construction on the Tesla Gigafactory in Nevada has begun in 2014, while Li-ion cell production is expected to begin in 2017. By 2020, the Gigafactory will reach full capacity, nothing less than an annual 35 GWh, which is sufficient to supply the production of 500,000 full EVs annually. Tesla's 2020 cost projections for a 10 kWh NCA battery-pack are around €3100.

Along with NCA batteries, Tesla Motors will produce in its Gigafactory also NMC cells, made from a LiNiMnCoO<sub>2</sub> cathode and a graphite anode. Compared to NCA, the NMC battery has lower specific energy, while it has a longer cycle life. The proportions of nickel, manganese and cobalt could be varied to influence the battery characteristics and provide thereby tailored solutions for specific applications. For instance increasing the share of nickel favours the specific energy, while increasing the share of manganese increases the specific power. Although the NMC battery was first commercialized as late as 2004 it has found meanwhile several applications including in consumer products, power tools, e-bikes, EVs and medical devices, while there are projections for grid-connect use for instance for load shift. This adapts well to tackle the increasing share of PV and wind power in the electricity grid. There is a long list of NMC cell manufacturers, including Ener 1, Evonik, GS Yuasa, Hitachi, LG Chem, Panasonic, PEVE, Samsung and Sanyo. Tesla's 2020 cost projections for a 7 kWh NMC battery-pack are around €2660, an average of €380/kWh.

It should be highlighted at this point that one appealing criterion behind Li-ion batteries is that their improvement potential is far from exhausted. Significant advances can be expected in the near future through nanotechnology. Nanomaterials with new chemical and physical properties can be developed with the purpose to create advanced cell components which result in a better battery performance, improved durability and higher safety. On the long run, more challenging concepts such as lithium-air batteries or Li-ion batteries based on electroactive organic materials could become reality. An overview on the trends and promising research areas for the next generations of Li-ion batteries is provided in the reference (Armand and Tarascon, 2008; Tarascon, 2010; Scrosati and Garche, 2010; Tao et al., 2011).

The application targeted in this paper requires in the first place a liable, durable, safe and eco-friendly solar battery with accept-

able short-term cost and significant foreseeable long-term cost reductions. Other aspects such as high specific energy and high specific power, which are priority factors in other Li-ion battery applications, such as EVs and portable electronics, are not determinant in this stationary application. In this sense, and considering the extensive overview that has been provided in this section for Li-ion batteries, the chemistries that adapt best for this application are LFP, LMO and NMC, barring in mind thereby that the last has the disadvantage of containing cobalt. All these batteries are already being successfully used in EVs under much tougher operating conditions than what a SHS requires. This fact is emphasized in Table 3. For further assessment of the SHS in this paper, the battery of choice is LFP.

A common rule of thumb for a SHS battery is a minimum autonomy of 2 days. This rule has been considered in the SHS simulation and optimization in iHOGA, which has been carried out for different locations within the Earth's Sunbelt. In all cases the outcome was that this minimum battery capacity was also the economically optimal solution. Thereby, iHOGA takes into account a wide range of PV generator size and battery capacity, performs the simulation for all possible combinations, considers further only those with uninterrupted power supply, and provides eventually the solution with the lowest NPC. The reason for this outcome is the relatively high specific cost of the Li-ion battery; any other solution with bigger battery, implies eventually higher SHS cost, even if it implies a smaller PV generator. Considering for the LFP battery a maximum depth of discharge of 85%, then the minimum battery capacity would be 2 kWh. The nominal LFP cell voltage is 3.3 V, while a battery pack that can provide 48 V is chosen for this application. This voltage requires connecting 15 LFP cells in series. Assuming a cell capacity of 10 Wh, the battery pack capacity is a multiple of 150 Wh. In this specific case 210 (14 × 15) cells would be required resulting in a battery-pack capacity of 2.1 kWh. Such an LFP battery-pack weights around 20 kg and is safe to install indoors. This provides ideal operating conditions, and practically detaches the battery from the climatic conditions of the installation site.

**Table 3**

Operating conditions of Li-ion battery in comparison between EV and SHS.

	EV Battery	SHS Battery
Operating climate	Diverse	Indoor installation
Ambient temperature range	-10 to 40 °C	10–30 °C
Mechanical stress	Vibration, acceleration, deceleration	Non (stationary)
Required P/E ratio	>2	<1
Recharge time requirements	<1 h (fast recharge)	5–10 h
Safety standards	Relatively high requirements <sup>a</sup>	Less challenging
Predominant SOC	30–100%	50–100%
Power variations	Very frequent, high amplitudes	Moderate

<sup>a</sup> Including crash test, needle penetration and similar without causing fire.

Assuming a life of 1800 full cycles, the battery would have a calendar life time slightly above 10 years.

#### 4. PV generator

In this section a brief overview about PV technology will be provided in terms of the state of the art and development tendencies, within the context of their relevance for this paper. This short review supports the key assumptions made here for the PV generator. Furthermore, the generator size for the SHS is calculated by iHOGA, taking thereby different geographic locations into account. Details on PV technology and development tendencies are obtained from the reference (Zubi, 2010). Information regarding the PV market growth of recent years as well as short-term growth estimates are extracted from the European Photovoltaic Industry Association report (EPIA, 2014). For details about commercial PV modules the database provided by Photon International is used (Photon, 2017).

PV provides clean sustainable energy which draws upon the planet's most plentiful and widely distributed renewable energy resource. First use of PV cells has been in the 1950s in space applications to provide power in Satellites. These cells were roughly 500 times more expensive than the ones produced today. Since then cost reductions have resulted in an expanding range of applications and accelerated market growth. In the 1970s PV reached a cost level where its use for off-grid power supply became profitable. Initially, profitability was limited to applications that provided high added value with small amount of energy and gradually expanded also to more energy intensive uses. In the 1990s PV systems started to find use in grid-connect applications. This use was not based on profitability and relayed heavily on support schemes like subsidies and feed-in tariffs. It was moved by the need to promote clean sustainable energy. Nevertheless, the learning rate for PV modules had already crystallized to 20%, putting grid-parity into scope and with that the eventual emancipation of grid-connected PV from financial support. In the last decade there have been also a massive proliferation of solar farms, especially in the USA, China and India. It's widely agreed that large PV farms installed in desert areas have a cost potential competitive with conventional central power plants. Today PV is already a major player in the global energy scenario; for instance, 57 GWp were installed globally in 2015. The favourable evolution of PV is strongly driven by its cost reductions. The impressive record to look back at today is just the iceberg-tip of a technology that has the potential to strongly contribute to putting right many of our urgent modern society needs, including the mitigation of global warming, energy sustainability and the global access to electricity. Currently, much focus in the grid-connected PV application is on the grid-parity and post grid-parity scenarios, among others on how to reduce grid integration costs to eventually be able to absorb a high PV share in the energy mix (Zubi, 2011) and this despite an also incremental wind power share (Zubi, 2009). On the other hand, much focus in off-grid PV is on how PV systems could contribute to modernizing the current supply and use of energy in developing regions away from the heavy reliance on traditional biomass and fossil fuels.

PV technology implies a wide range of commercially used and emerging materials. A summary of PV cell technologies with their record efficiencies is provided in the reference (NREL, 2017). The high relevance PV research areas are generally improvement in efficiency and long-term performance, cost reductions, large-scale manufacturability, reliance on abundant materials, carbon footprint reduction and avoidance of other environmental impacts. Apart from this common general pattern, the research focus varies among the different PV materials depending on their stage of

development. On the commercial level, PV is strongly dominated by c-Si (crystalline Silicon) with a market share historically above 75%. Best commercial c-Si modules perform today with an efficiency slightly above 20%. The current PV perspective regarding cost reductions to the level of grid-parity in extensive and extending geographic areas with abundance of materials to allow accelerated and persisting PV market growth to the level of substantial share in global power supply are based on the state of the art and foreseeable evolution for c-Si. In other words, these are realistic predictions that don't take into account potential breakthroughs in emerging PV technologies. This is one of the very promising aspects of PV; the clear perspectives for c-Si are very positive, while the currently unclear perspectives for emerging technologies could only be better for them to prevail.

The calculation of the PV generator size and tilt for the SHS is carried out using iHOGA based on the following inputs: latitude and longitude of the installation's site, monthly average of daily solar radiation, monthly average temperature, power demand curve of the used electric appliances and the basic characteristics of the PV generator, battery and BMS. From the monthly average of daily solar radiation, obtained from the reference (NASA, 2017), iHOGA generates the hourly solar radiation values for an entire year applying the method of Graham and Hollands (Graham and Hollands, 1990). The SHS simulation is then carried out in hourly steps for its entire lifetime. For the power consumption, the simplified demand profile detailed in Section 2 is used. Based on the elaborated in Section 3, the chosen battery technology is a 2.1 kWh 48 V LFP battery. The SHS simulation carried out in this paper assumes an efficiency degradation of the PV generator of 8% after 10 years, a battery roundtrip efficiency of 94% and a performance ratio of 0.78. It is also assumed that the BMS includes an MPPT (Maximum Power Point Tracker).

Nine reference locations have been used in the iHOGA simulation: North India (32°N, 77°E), Central India (24°N, 79°E), South India (12°N, 77°E), North Pakistan (32°N, 72°E), South Pakistan (22°N, 66°E), Kalimantan (1°S, 114°E), Java (8°S, 111°E), Tanzania (2°S, 34°E) and Spanish Pyrenees (42.5°N, 0.3°W). This last location is out of the geographic area of interest and is added here for the purpose of providing contrast. The PV generator size has been calculated by iHOGA at 420 Wp for North, Central and South India as well as South Pakistan. For North Pakistan, Kalimantan and Java a PV generator of 360 Wp would suffice. For the considered location in Tanzania the PV generator size has been calculated at 320 Wp. For the Spanish Pyrenees, a PV generator of 820 Wp would be needed to be able to overcome the winter months without power interruptions. For each location the optimal PV panel slope is calculated by iHOGA under the condition of a minimum slope of 15° (lower slope may result in frequent dust and dirt accumulation on the module's surface). The results obtained for the different locations are: 15° for Central and South India, South Pakistan, Kalimantan, Java and Tanzania, 30° for North Pakistan, 50° for North India and 60° for the Spanish Pyrenees.

As the iHOGA simulation and optimization shows, a PV generator size of 420 Wp is sufficient for a wide implementation of this SHS within the Earth's Sunbelt. For many locations a smaller generator would suffice. It has to be highlighted though that the PV generator size has a relatively minor effect on the SHS initial investment; 50 Wp more or 50 Wp less imply a difference of less than 3% on the initial investment. Furthermore, taking into account that a bigger PV generator contributes positivity to the battery lifetime, the impact on the NPC is even less. Finally, a bigger PV generator improves to some extent the SHS reliability. Therefore, this paper opts for a SHS with a 420 Wp PV generator as a standard solution. This specific layout will be used for further assessment in this paper.



## 5. Evolutionary assessment

Fig. 1 shows the SHS layout, in line with the elaborated in Sections 2–4. The main components are the 420 Wp PV generator, the 2.1 kWh 48 V LFP battery with BMS, the 700 W Multicooker, a total of 60 W LED lamps and the U-socket. The main system voltage is 48 V. The multicooker feeds directly on the main line, while the LED lamps operate at 12 V and therefore require a 48–12 V DC-DC converter. Finally, the U-socket integrates a DC-DC converter to provide a standard 5 V. The SHS can be built and used with high safety standards. Except for the PV generator, all system components are installed indoors. The calendar lifetime of all components is 10+ years, except for the multicooker, which has to be completely replaced after roughly 5 years.

One important aspect to tackle in a SHS layout is how sensitive is it in terms of power supply reliability to deviations from the assumed energy demand curve, both in terms of demand shift from day to night and of higher demand in some occasions by the consumer. The here assumed demand curve with cooking for lunch during midday and cooking for dinner, lighting and the recharge of portable electronics during night, is realistic, and only minor deviations would take place under real conditions. Most of the energy consumed by the electric appliances comes from the battery; the direct consumption from the PV generator is around 15%. Even assuming a demand curve where practically the entire energy consumption takes place during the night hours, i.e. cooking for lunch is done the night before and the food is just heated at lunch time, and this as a daily habit, then the effect would be eventually a shortening in the battery lifetime of roughly 1 year. An occasional higher daily demand than the considered in the system layout, for instance 1 kWh instead of 0.85 kWh would generally not lead to power interruption. This has to do with the fact that the SHS layout considers proper functionality until the day the installation is obsolete. The proper consideration of ageing mechanisms in the system layout implies that the PV generator and battery over-perform until their last year of operation. Furthermore, the iHOGA simulation calculates a PV generator size that guarantees a daily demand of 0.85 kWh during the lowest radiation month. For the rest of the year, the available electric power is significantly above that. To conclude, power interruptions would take

place if the demand is substantially beyond (20% and more) the predefined 0.85 kWh, it takes place during the lowest solar radiation season and this at an advanced stage of the SHS lifetime. It has to be highlighted at this point that these power supply conditions with a SHS are way better than those in many grid-connected developing regions.

Table 4 summarizes the cost evolution of the SHS technology for the time-frame 2020–2035 in 5-year steps. Industry projections have been taken into account to provide a cost estimate for the LFP battery; a specific cost of €600/kWh is assumed for 2020 (current costs are roughly around €700/kWh). Furthermore, an annual cost reduction of 4% is considered for the battery technology, leading to a battery cost of €325/kWh in 2035. As for the PV generator, the current manufacturing cost for c-Si PV modules is around €0.55/W. Considering 10% overhead and 25% benefit margin, the factory gate price is €0.76/W. Assuming trade costs of €0.2 and 15% VAT (Value Added Tax), then a consumer price of €1.1/W would result. Based on the PV learning rate of 20% and realistic market growth estimates, it is safe to assume a module price of €0.86/W in 2020, €0.78/W in 2025, €0.7/W in 2030 and €0.63/W in 2035. These prices apply for the simple consumer for a PV generator roughly above 200 Wp and are exclusive of delivery costs. Finally, the cost of the multicooker is assumed to be €90 and no cost reductions over time are considered. This implies that new models would include technological advances at the same price. On the other hand, it is assumed that LED lamps cost €0.8/W in 2020, dropping to €0.5/W in 2035. The resulting SHS investment in Table 4 is €2079 in 2020 and drops to €1308 in 2035, which implies an average annual cost reduction of 3% for the technology. The technology improves also over time in terms of calendar lifetime due to the longer durability of later generation batteries. As costs after installation are moderate, the difference between the NPC and the initial investment is in all cases below 10%.

To be able to compare the SHS with the current practices for cooking and lighting under energy poverty a representative scenario for this BaU (Business as Usual) situation is needed. Kerosene-based assumptions are taken as a reference in this paper. Taking into account the average price of international crude oil of the last 10 years, and adding to it 20% refinery costs and 25% trade costs, and considering an average kerosene consumption per

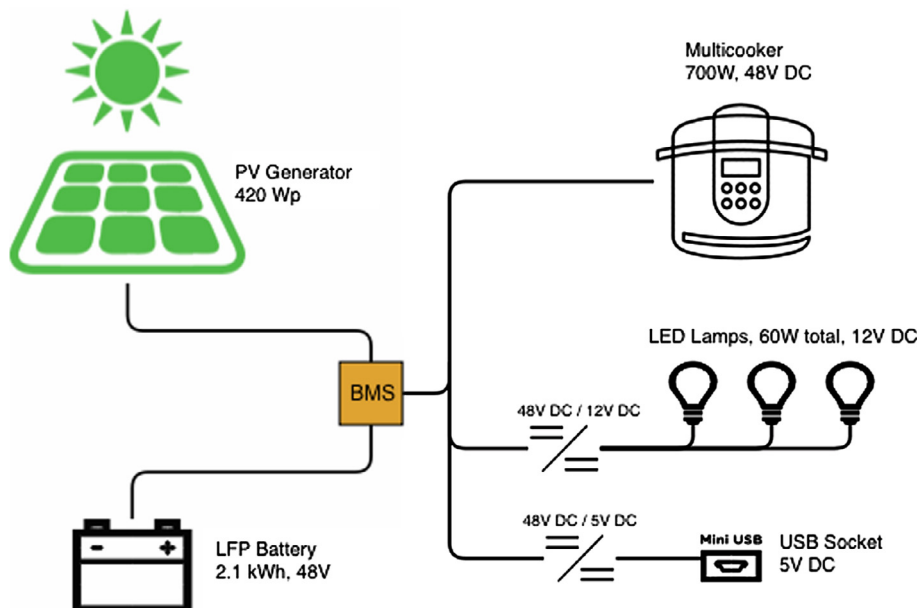

Fig. 1. SHS layout.

**Table 4**  
Initial investment and NPC evolution for the SHS technology for the time-frame 2020–2035.

	2020	2025	2030	2035
Battery-pack cost, 2.1 kWh LFP	€1260	€1027	€838	€683
PV Generator cost, 420 Wp	€361	€328	€294	€265
Other SHS components	€150	€130	€120	€120
SHS Transport and Installation	€170	€150	€130	€120
Multicooker cost	€90	€90	€90	€90
LED lamps, 60 W total	€48	€42	€36	€30
SHS calender lifetime	10	12	14	15
<b>SHS initial investment</b>	<b>€2079</b>	<b>€1767</b>	<b>€1508</b>	<b>€1308</b>
<b>SHS NPC</b>	<b>€2146</b>	<b>€1885</b>	<b>€1626</b>	<b>€1426</b>

The lifetime of the SHS is that of the battery, the residual value of the longer lasting components, such as the PV generator, are considered similar to the dismantling and collection costs. All NPC values take an interest rate of 6% into account. A replacement of the multi-cooker every 5 years is considered.

family (roughly 5–6 members) for cooking and lighting of 23 L/M (liters per month), then a monthly kerosene cost of €15/M per family would result. The here assumed trade cost of 25% the crude oil price includes transportation and trade profits and applies for well communicated regions. In developing countries this is often limited to cities and their peripheries, but not for remote areas. This is why it's more representative to consider a price range, which is in this case €15–25/M. As LPG is more delicate than kerosene in terms of transportation and storage, it is slightly more expensive. On the other hand, traditional biomass, such as firewood, could be practically available for free, but it's collection implies much work. Even at an average of 1 h biomass collection per day, the working hour value would be equivalent to €0.5 if compared with the €15/M for kerosene. It is realistic to assume that after 2030 crude oil prices will be notably higher than today. This will cause a shift of the cost range to €20–30/M. The monthly payment for the fossil fuel over the lifetime of the SHS is used to calculate the NPC of the BaU scenario. Thereby €70 upfront costs are considered for the purchase of kerosene lamps and a cookstove, and the same amount for their replacement every 5 years. The resulting contrast between the SHS and the BaU scenarios is illustrated in Fig. 2.

The total balance in the economic comparison between the SHS and the BaU scenario results on the short term in a SHS advantage conditioned to a relatively high fuel cost, for instance €25/M. On the other hand, at a cost of €15/M and similar, traditional cooking and lighting would result cheaper. By 2028 the SHS would be in any case the better economic option. Thereby, there is an incremental advantage over time of the SHS over the BaU scenario. On the long run, traditional cooking and lighting would be roughly twice as costly as the SHS solution detailed in this paper.

Fig. 2 does not consider the SHS carbon abatement. Taking this into account would result in an advantage of the SHS over the BaU scenario with low fossil fuel cost earlier than 2028. For instance a SHS installed in 2025 would save 8.5 equivalent tons of CO<sub>2</sub> along

it's lifetime of 12 years. Assuming a carbon cost of €25 per ton CO<sub>2</sub>, the 8.5 tons would make a difference of €213 and would put the SHS in parity with the BaU scenario with low fossil fuel cost already at this stage. This carbon abatement value of 8.5 tons in 2025 is based on the CO<sub>2</sub> emission coefficient of kerosene of 2.58 kg/L, plus 7% indirect emissions and a monthly demand of 23 L. On the other hand, for the SHS life-cycle emissions of 0.6 equivalent CO<sub>2</sub> tons are considered, which takes into account 80 kg CO<sub>2</sub> per kWh of battery capacity, 600 kg CO<sub>2</sub> per kWp of PV module and 180 kg CO<sub>2</sub> for the other SHS components and transportation.

As the here provide SHS is very specific, it's convenient to also give at this point an overview on this SHS technology beyond this representative case study. In a previous paper, the first author has considered multiple demand profiles based on different combinations of domestic electric appliances for lighting, cooking and food conservation and analysed their effect on the SHS layout and economy (Zubi et al., 2016a). The general conclusion is that although adding more electric appliances, i.e. increasing the energy demand, results in substantially lower LCoE (Levelized Cost of Electricity), it increases notably the initial investment, easily beyond the affordability barriers for poor families in developing regions, due to the need for a bigger battery and PV generator as well as for the purchase of electric appliances. It was also concluded that the different demand profiles of appliances result in a specific impact on the SHS. For instance, a fridge is an energy intensive appliance, but operates at low power with substantial demand during day time, circumventing the battery and consuming directly from the PV generator. This results in a favourable impact on the battery lifetime and the LCoE. In contrast, cooking appliances are power intensive and therefore much more reliant on the battery. Finally, lighting consumes exclusively from the battery as it's typically needed after sunset. Nevertheless, independently if the demand profile of an electric appliance is battery friendly or hostile, the set of priorities is determined by the energy consumer based on

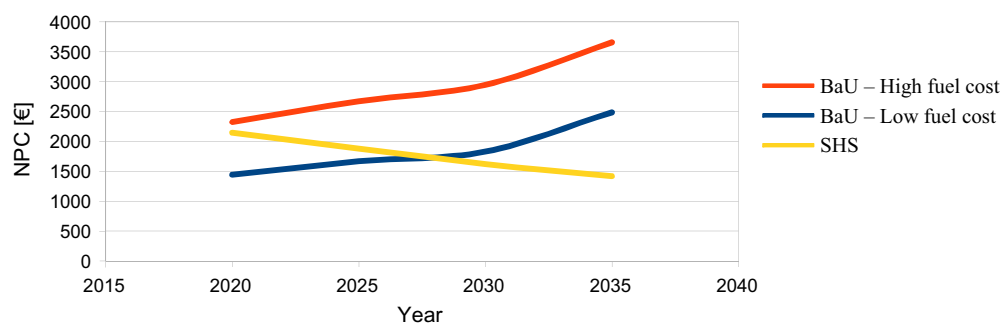

**Fig. 2.** Evolutionary NPC of the SHS technology versus the BaU Scenario. Low fuel cost: €15/M on the short term going up to €20/M on the long term. High fuel cost: €25/M on the short term going up to €30/M on the long term.

the added value of the appliances, which is general first energy for lighting and portable electronics, then for cooking and then for food conservation and later the rest. The guidelines highlighted in this paper for the calculation of the battery capacity and PV generator size apply equally for other SHS configurations within the Earth's Sunbelt region.

## 6. Conclusions

A SHS for cooking and lighting for implementation within the Earth's Sunbelt as a solution for domestic energy poverty has been developed and assessed in this paper. The most outstanding characteristic of the SHS is its energy efficiency; LED lamps and multi-cookers near the theoretical efficiency limit for such appliances, while providing excellent added value. As additional to this, the power generation is from a renewable source, the environmental impact and stress on resources are minimal. By assuring a monthly electricity supply of 24 kWh, the SHS replaces 23 L of kerosene, i.e. 238 kWh of fuel energy. This gives almost a relation of 10 to 1 and emphasizes what a waste of energy lighting and cooking with kerosene is. The picture for traditional biomass is even more grim.

The standard battery in SHS is currently the lead-acid, several advantages, however, result from opting for an LFP battery, including high reliability, low maintenance requirements, long cycle and calendar lifetime, high energy density, reliance on eco-friendly materials and safety. These allow for indoor installation, which assures relatively constant and favourable operating conditions.

Although it was not the initial purpose of this work, an interesting outcome is the feasibility of a standard SHS that can be widely implemented within the Earth's Sunbelt as a solution for domestic energy poverty. This has basically resulted through the choice of the battery technology; due to the relatively high specific cost of the LFP battery, the economically optimal battery capacity is the smallest compliant with the required minimum autonomy of 2 days. On the other hand, the required PV generator size does depend on the installation site, but, within the Earth's Sunbelt, this has a modest effect on the SHS cost. Standard SHS solutions are cheaper and easier to implement.

SHS solutions are economically competitive on an NPC basis already on the short term, while having a clear incremental advantage over time over traditional practices for cooking and lighting. Nevertheless, the initial costs for such systems are generally prohibitive for families living under energy poverty. On the other hand, as SHS can tackle many problems of national and global concern, including human development, health and safety concerns, sustainability of resources and the environmental impact of energy, quantifying these advantages and transforming them in subsidies, compensations and similar is by all means justified and recommended. A major role should be played in this sense by policy makers. Successful implementation could be achieved, for instance, by a financing scheme that includes a micro-credit and government support that deviates fossil fuel subsidies and compensates for carbon abatement. This would allow to fragment the initial investment into minor upfront costs, similar to the purchase of kerosene lamps and cookstove, and a monthly payment, similar and eventually lower than the cost for the purchase of fossil fuels. Such scheme could be implemented until 2030, after that, minor measures would be required, if at all. In this sense, while solar energy leads to a solution for energy poverty and emancipation from government support, fossil fuels imply incremental addiction on subsidies for the discrete purpose of alleviating energy poverty.

Finally, the approach proposed in this paper allows developing regions to profit from relevant synergies with the global community instead of having a go-alone solution that brings little technological improvements, if at all, over time. The SHS technology puts

the developing and developed world on a common low-carbon path with exploitable synergies in battery technology, photovoltaics and domestic electric appliances. This paper confirms eventually the well-known fact that technology-based solutions, such as SHS, become cheaper over time following the learning curve, while resource-based solutions, such as cooking and lighting with fossil fuels, can only become more expensive due to resource depletion. In this sense, it's not wise to only consider current costs but also to focus on the long term tendencies of solutions and base policies and decisions on these.

## References

- Abu-Malouh, R., Abdallah, S., Muslih, I.M., 2011. Design, construction and operation of spherical solar cooker with automatic sun tracking system. *Energy Convers. Manage.* 52, 615–620.
- Adaramola, M.S., Ageling-Chaab, M., Paul, S.S., 2014. Analysis of hybrid energy systems for application in southern Ghana. *Energy Convers. Manage.* 88, 284–295.
- Ahlborg, H., Hammar, L., 2014. Drivers and barriers to rural electrification in Tanzania and Mozambique – grid extension, off-grid, and renewable energy technologies. *Renewable Energy* 61, 117–124.
- Akikur, R.K., Saidur, R., Ping, H.W., Ullah, K.R., 2013. Comparative study of stand-alone and hybrid solar energy systems suitable for off-grid rural electrification: a review. *Renew. Sustain. Energy Rev.* 27, 738–752.
- Al-Karaghoul, A., Kazmerski, L.L., 2010. Optimization and life-cycle cost of health clinic PV system for a rural area in southern Iraq using HOMER software. *Sol. Energy* 84, 710–714.
- Armand, M., Tarascon, J.M., 2008. Building better batteries. Researchers must find a sustainable way of providing the power out modern lifestyles demand. *Nature* 451, 652–657.
- Bardan, A.A., Yousef, I.A., Joudeh, N.K., Al-Hamad, R., Halawa, H., Hassouneh, H.K., 2010. Portable solar cooker and water heater. *Energy Convers. Manage.* 51, 1605–1609.
- Barré, A., Deguilhem, B., Grolleau, S., Gérard, M., Suard, F., Riu, D., 2013. A review on lithium-ion battery ageing mechanisms and estimations for automotive applications. *J. Power Sources* 241, 680–689.
- Bekele, G., Palm, B., 2010. Feasibility study for a stand-alone solar-wind based hybrid energy system for application in Ethiopia. *Appl. Energy* 87, 487–495.
- Bernal-Agustín, J.L., Dufo-López, R., 2009. Simulation and optimization of stand-alone hybrid renewable energy systems. *Renew. Sustain. Energy Rev.* 13, 2111–2118.
- Borhanazad, H., Mekhilef, S., Saidur, R., Boroumandjazi, G., 2013. Potential application of renewable energy for rural electrification in Malaysia. *Renewable Energy* 59, 210–219.
- Boucar, D., Ramchandra, P., 2015. Potential of lithium-ion batteries in renewable energy. *Renewable Energy* 76, 375–380.
- Carroquino, J., Dufo-López, R., Bernal-Agustín, J.L., 2015. Sizing of off-grid renewable energy systems for drip irrigation in Mediterranean crops. *Renew Energy* 76, 566–574.
- Deutsche Bank, 2008. Electric Cars: Plugged in – Batteries Must Be Included. Fundamental, Industry, Thematic, Thought Leading (FITT).
- Deutsche Bank, 2009. Electric Cars: Plugged in 2 - A Mega Theme Gains Momentum. Fundamental, Industry, Thematic, Thought Leading (FITT).
- Dufo-López, R., Bernal-Agustín, J.L., Yusta-Loyo, J.M., Domínguez-Navarro, J.A., Ramírez-Rosado, I.J., Lujano, J., Aso, I., 2011. Multi-objective optimization minimizing cost and life cycle emissions of stand-alone PV-wind-diesel systems with batteries storage. *Appl. Energy* 88, 4033–4041.
- Dufo-López, R., Zubi, G., Fracastoro, G.V., 2012. Techno-economic assessment of an off-grid PV-powered community kitchen for developing regions. *Appl. Energy* 91, 255–262.
- Dufo-López, R., Pérez-Cebollado, E., Bernal-Agustín, J.L., Martínez-Ruiz, I., 2016. Optimisation of energy supply at off-grid healthcare facilities using Monte Carlo. *Energy Convers. Manage.* 113, 321–330.
- European Photovoltaic Industry Association (EPIA), 2014. Global market outlook for photovoltaic 2014–2018.
- Graham, V.A., Hollands, K.G.T., 1990. A method to generate synthetic hourly solar radiation globally. *Sol. Energy* 44, 333–341.
- Ibrahim, M., Anisuzzaman, M., Kumar, S., Bhattacharya, S.C., 2002. Demonstration of PV micro-utility system for rural electrification. *Sol. Energy* 72, 521–530.
- iHOGA Software, 2017. <<http://personal.unizar.es/rdufo/index.php?lang=en>>.
- International Energy Agency (IEA), 2011. Technology Roadmap – Electric and plug-in hybrid electric vehicles.
- Jung, J., Zhang, L., Zhang, J., 2015. Lead-Acid Battery Technologies: Fundamentals, Materials and Applications. CRC Press.
- Kumar, N., Chavda, T., Mistry, H.N., 2010. A truncated pyramid non-tracking type multipurpose domestic solar cooker/hot water system. *Appl. Energy* 87, 471–477.
- Lam, N.L., Smith, K.R., Gauthier, A., Bates, M.N., 2012. Kerosene: a review of household uses and their hazards in low- and middle-income countries. *J. Toxicol. Environ. Health Part B* 15, 396–432.

- Lowe, M., Tokuoka, S., Trigg, T., Gereffi, G., 2010. Lithium-Ion Batteries for Electric Vehicles: The U.S. Value Chain. Center on Globalization, Governance & Competitiveness.
- Mohammed, Y.S., Mustafa, M.W., Bashir, N., 2014. Hybrid renewable energy systems for off-grid electric power: review of substantial issues. *Renew. Sustain. Energy Rev.* 35, 527–539.
- Nitta, N., Wu, F., Lee, J.T., Yushin, G., 2015. Li-ion battery materials: present and future. *Mater. Today* 18, 252–264.
- US National Aeronautics and Space Administration (NASA), 2017. Atmospheric Science Data Center. Surface meteorology and solar energy. <<https://eosweb.larc.nasa.gov/sse/RETScreen/>>.
- US National Renewable Energy Laboratory (NREL), 2017. Best PV research-cell efficiencies. <<http://www.nrel.gov>>.
- Pavlov, D., 2011. Lead-Acid Batteries: Science and Technology. Elsevier.
- Photon, 2017. <[http://www.photon.info/photon\\_site\\_db\\_solarmodule\\_en.photon](http://www.photon.info/photon_site_db_solarmodule_en.photon)>.
- Prasanna, U.R., Umanand, L., 2011. Modeling and design of a solar thermal system for hybrid cooking application. *Appl. Energy* 88, 1740–1755.
- Raji Reddy, A., Narasimha Rao, A.V., 2007. Prediction and experimental verification of performance of box type solar cooker – Part I. Cooking vessel with central cylindrical cavity. *Energy Convers. Manage.* 48, 2034–2043.
- Ranaboldo, M., Domenech, B., Alberto Reyes, G., Ferrer Martí, L., Pastor Moreno, R., Gacía-Villoria, A., 2015. Off-grid community electrification projects based on wind and solar energies: a case study in Nicaragua. *Sol. Energy* 117, 268–281.
- Reddy, T.B., 2011. Linden's Handbook of Batteries. McGraw Hill.
- Scrosati, B., Garche, J., 2010. Lithium batteries: status, prospects and future. *J. Power Sources* 195, 2419–2430.
- Sinha, S., Chandel, S.S., 2014. Review of software tools for hybrid renewable energy systems. *Renew. Sustain. Energy Rev.* 32, 192–205.
- Suresh Kumar, U., Manoharan, P.S., 2014. Economic analysis of hybrid power systems (PV/diesel) in different climatic zones of Tamil Nadu. *Energy Convers. Manage.* 80, 469–476.
- Tao, H., Feng, Z., Liu, H., Kan, X., Chen, P., 2011. Reality and future of rechargeable lithium batteries. *Open Mater. Sci. J.* 5, 204–214.
- Tarascon, J.M., 2010. Key challenges in future Li-battery research. *Philosop. Trans. Roy. Soc. A* 368, 3227–3241.
- United Nations Development Program (UNDP), 2011. Human development report 2011. Sustainability and equity: a better future for all.
- United Nations Development Program (UNDP), 2013. Human development report 2013. The rise of the south: human progress in a diverse world.
- United Nations Development Program (UNDP), 2014. Human development report 2014. Sustaining human progress: reducing vulnerability and building resilience.
- Wang, Q., Ping, P., Zhao, X., Chu, G., Sun, J., Chen, C., 2012. Thermal runaway caused fire and explosion of lithium ion battery. *J. Power Sources* 208, 210–224.
- Wen, J., Yu, Y., Chen, C., 2012. A review on li-ion batteries safety issue: existing problems and possible solutions. *Mater. Express* 2, 197–212.
- Williard, N., He, W., Hendricks, C., Pecht, M., 2013. Lessons learned from the 787 Dreamliner issue on lithium-ion battery reliability. *Energies* 6, 4682–4695.
- World Health Organization (WHO), 2011. Health impacts of indoor air pollution. <[http://www.who.int/indoorair/health\\_impacts/en/](http://www.who.int/indoorair/health_impacts/en/)>.
- Zubi, G., Bernal Agustin, J.L., Fandos Marin, A.B., 2009. Wind energy (30%) in the Spanish power mix – technically feasible and economically reasonable. *Energy Policy* 37, 3221–3226.
- Zubi, G., 2010. Future of distributed grid-connected PV in Southern Europe Phd dissertation. Polytechnic University of Turin and University of Zaragoza.
- Zubi, G., 2011. Technology mix alternatives with high shares of wind power and photovoltaics – case study for Spain. *Energy Policy* 39, 8070–8077.
- Zubi, G., Dufo-López, R., Pasaoglu, G., Pardo, N., 2016a. Techno-economic assessment of an off-grid PV system for developing regions to provide electricity for basic domestic needs: a 2020–2040 scenario. *Appl. Energy* 176, 309–319.
- Zubi, G., Dufo-López, R., Pardo, N., Pasaoglu, G., 2016b. Concept development and techno-economic assessment for a solar home system using lithium-ion battery for developing regions to provide electricity for lighting and electronic devices. *Energy Convers. Manage.* 122, 252–264.