

Wireless Sensor Network for Distributed Environmental Monitoring

Original

Wireless Sensor Network for Distributed Environmental Monitoring / Lombardo, Luca; Corbellini, Simone; Parvis, Marco; Elsayed, Ahmed; Angelini, Emma; Grassini, Sabrina. - In: IEEE TRANSACTIONS ON INSTRUMENTATION AND MEASUREMENT. - ISSN 0018-9456. - STAMPA. - 67:5(2018), pp. 1214-1222. [10.1109/TIM.2017.2771979]

Availability:

This version is available at: 11583/2700938 since: 2020-02-17T10:27:24Z

Publisher:

Institute of Electrical and Electronics Engineers Inc.

Published

DOI:10.1109/TIM.2017.2771979

Terms of use:

This article is made available under terms and conditions as specified in the corresponding bibliographic description in the repository

Publisher copyright

IEEE postprint/Author's Accepted Manuscript

©2018 IEEE. Personal use of this material is permitted. Permission from IEEE must be obtained for all other uses, in any current or future media, including reprinting/republishing this material for advertising or promotional purposes, creating new collecting works, for resale or lists, or reuse of any copyrighted component of this work in other works.

(Article begins on next page)

© 2018 IEEE. Personal use of this material is permitted. Permission from IEEE must be obtained for all other uses, in any current or future media, including reprinting/republishing this material for advertising or promotional purposes, creating new collective works, for resale or redistribution to servers or lists, or reuse of any copyrighted component of this work in other works.

Title: Wireless Sensor Network for Distributed Environmental Monitoring

Authors:

Luca Lombardo

Dept. of Electronics and Telecommunications, Politecnico di Torino, Torino, Italy

Simone Corbellini

Dept. of Electronics and Telecommunications, Politecnico di Torino, Torino, Italy

Marco Parvis

Dept. of Electronics and Telecommunications, Politecnico di Torino, Torino, Italy

Ahmed Elsayed

Dipartimento di Scienza Applicata e Tecnologia, Politecnico di Torino, Torino, Italy

Emma Angelini

Dipartimento di Scienza Applicata e Tecnologia, Politecnico di Torino, Torino, Italy

Sabrina Grassini

Dipartimento di Scienza Applicata e Tecnologia, Politecnico di Torino, Torino, Italy

DOI: 10.1109/TIM.2017.2771979

Wireless Sensor Network for Distributed Environmental Monitoring

Luca Lombardo *Student Member, IEEE*, Simone Corbellini *Member, IEEE*, Marco Parvis *Fellow, IEEE*, Ahmed Elsayed, Emma Angelini, Sabrina Grassini *Member, IEEE*

Abstract—Environmental monitoring is extremely important to ensure a safe and wealthy life of both humans and artifacts. Monitoring requirements are extremely different depending on the environment, leading to ad-hoc implementations that lack flexibility. This paper describes an implementation that can be adapted to many different applications and embeds the flexibility required to be deployed and upgraded without the necessity of arranging complex infrastructures. The solution is based on small autonomous wireless sensor nodes, small wireless receivers connected to the Internet and a cloud architecture which provides data storage and delivery to remote clients. The solution permits supervisors on-site to have an immediate idea of the current situation by using their smart-phones, but also to monitor remote sites through the Internet. All measurements are redundantly stored at different concentration levels to guarantee a safe backtrace and to provide quality assurance also in case of network failure or unavailability. The sensing nodes have small impact, with dimensions which can be of less than 2.5 cm x 1.5 cm when the nodes have to acquire only temperature and relative humidity, and a low cost that enables using them in a set-and-forget way for intervals in excess of one year.

Index Terms—Environmental monitoring, Wireless Sensor Network, History, Measurement Techniques, Quality assurance

I. INTRODUCTION

Environmental monitoring issues and architectures are deeply investigated in the literature and the interest of the instrumentation and measurement community for this important topic is highlighted also by the establishment of a specific technical committee [1].

Several papers deal with the development of low-cost monitoring networks [2–4], most of them focused on home applications, on sensor development [5] and on network aspects [6]. However, less attention is paid to the monitoring of climate parameters inside heritage buildings and museums where only non invasive systems can be employed in order to avoid any impact on the visitor fruition and on the aesthetic appearance of showcases and rooms. Furthermore, monitoring is not an end in itself, but it is a means to find out what the environmental conditions are and whether they have to be controlled to ensure the long-time preservation of the artifacts. For these reasons the assurance of quality and reliability of the measurements in long-term monitoring activities is absolutely required.

This paper describes a multi-layer architecture for distributed environmental monitoring able to satisfy most of the

requirements of the cultural heritage field, even if its particular features make it suitable for many other applications where a minimal invasiveness is required. The very flexible architecture developed can operate by providing data access and system configuration tools through wi-fi connection, but also in an off-line scenario where no power supply or Internet connection are available. The wireless sensor network is implemented by means of small sensing nodes that have dimensions of few centimeters and do not require any cabling or power supply. Actually, the system is designed to measure temperature and relative humidity. Anyhow, the node hardware can be easily arranged to detect also many different air pollutants, although reaching the sensitivities often required for a safe conservation of the heritage artifacts can be a challenge [7–9].

II. THE PROPOSED SYSTEM ARCHITECTURE

Nowadays several solutions for monitoring different environmental parameters, based on wireless nodes, have been proposed [10–17]. The solution described in this paper, even though conceived with a similar approach, pays particular attention to the data storage and safety.

The proposed architecture relies on a three-level data storage, which provides a strong data safety. In particular, it gives the possibility to retrieve the whole measurement history of the monitored site, avoiding any issue connected with cabling and network connection break.

Fig. 1 shows the block diagram of the proposed three-level architecture:

- Level #1 is represented by the sensor nodes. The nodes, described in details in the following section, have the peculiarity of embedding a local non-volatile memory for storing all measurements and raw data collected by the sensors during the network operative state. Each node has an Unique Identifier Data (UID) which is written inside the firmware and can not be changed. The firmware is designed to never overwrite the measurements stored in the local memory. After the battery is installed, the node starts measuring at 15 min intervals storing the measurements into the memory. At this pacing the local non-volatile memory has the capability of storing data for up to 3 years, which is also the expected life of the battery. It is not possible to tamper with the measurements unless a physical access to sensor is provided. The firmware lets users change only the measurement timing. Even when the battery is completely discharged it is still possible to retrieve the measurements by connecting the sensor circuit to a proper programming board.

S. Grassini, A. Elsayed, and E. Angelini are with the Department of Applied Science and Technology, Politecnico di Torino, Italy,

S. Corbellini, L. Lombardo and M. Parvis are with Department of Electronics and Telecommunications, Politecnico di Torino, Italy.

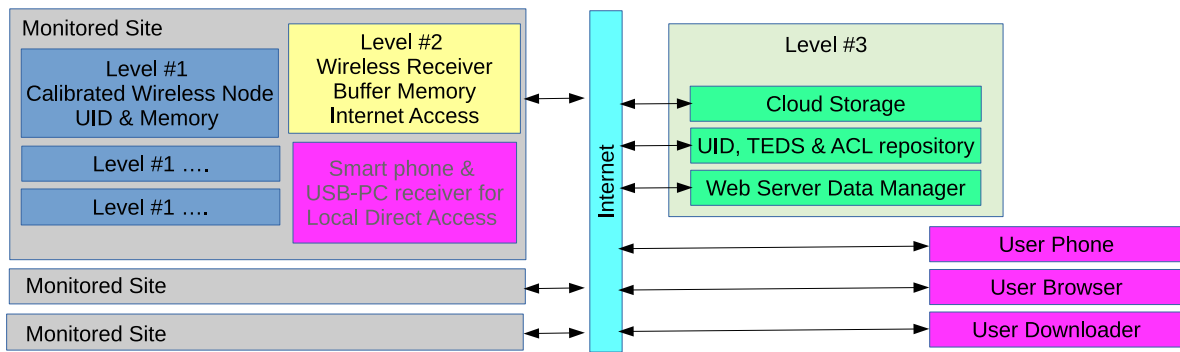

Fig. 1. Block diagram of the proposed architecture with three-level data storage.

Each node, after manufacturing, is calibrated by direct comparison with reference sensors. All calibration constants are used to arrange a Transducer Electronic Data Sheet (TEDS), which is associated to sensor UID and stored in the remote cloud memory. The calibration data are not stored in the node firmware so that each node can be re-calibrated and/or checked without altering its firmware or interfering with the on-going measurement. Even though this approach requires the users to access the remote cloud repository in order to obtain the best node accuracy, it is intrinsically safe with respect to any kind of hacking. In the absence of TEDS access, users can still compute the relevant quantities by using the nominal sensor constants, so an approximate estimation can be always obtained. The nodes have wireless capability thanks to the Bluetooth Low Energy (BT-LE) protocol, which allows sending all data to a receiver up to a distance of at least 10 m.

- Level #2 is represented by the receivers, usually one per room, which act as the bridge between the sensing nodes and the Internet. The receivers are able to gather data from all the measuring nodes, which are within their receiving range, and to send them to the remote storage via an Internet connection. Since they have to remain on-line to transmit the measurements in real time, they need to be continuously connected to a power supply. The receivers have their own UID and are battery backed so they can work also if the power supply goes off for a maximum of three days. They implement also a local storage where the measurements sent by the nodes are stored till it is possible to deliver them to the remote repository. This way the data transfer over the Internet can be deferred for a few days in the case a connection cannot be established. Using this buffer memory increases the possibility of delivering the measurements to the remote repository even though a connection channel is available only on an intermittent basis, like in the case of phone-assisted data traffic.
- Level #3 is represented by a distributed cloud storage. All data from all nodes are stored into a cloud database and can be retrieved by authorized users. Apart from the storage, the picture shows two important functions as separate blocks. The first block is represented by the UID, TEDS & Access Control List (ACL) repository. It stores the node conditions, the last data sent to the cloud, the calibration constants and the results of any periodical re-calibration to assure the quality and reliability of the measurements. In addition, this block plays also an important role in defining the user access rights, via the ACL manager. As explained later, each user is granted the possibility of seeing data coming from specific receivers so the users are free to add and move nodes which are within the receiver range. Should the receivers have a problem and an administrative action is required to download data directly from the nodes, such data are inserted into the database on behalf of the receiver and made available to the users. The second block is represented by the Web Server data manager, which actually lets users access the node measurements. The server can arrange web pages to show selected data, identified by UID and time intervals, to the authorized users. The authorization structure allows also for the possibility of granting partial data visibility to additional users with specific credentials or either to all users without authentication, if required.
- The user clients that receive the measurements represent the last element in the network. The figure shows three types of clients: the user browser, the user smart-phone and the user downloader. The user browser lets users access data via Internet, without installing any specific software. The user smart-phone, in addition to the browser, allows following the measurements in real time via the *μPanel* App [18]. The user downloader, which is a dedicated software provided by the administrator or developed by the users, allows downloading the measurements by specific socket commands and processing the data according to the user needs. Finally, the figure shows the possibility of using either a smart-phone or a BT-LE enabled PC, taken close to the nodes, to directly monitor the collected values in the case an Internet connection is not available. In particular, the *μPanel* architecture permits real-time control of sensors and receivers even locally without requiring Internet connection.

III. THE MEASUREMENT NODES

Most of the commercial environmental monitoring systems [19, 20] are not designed for guaranteeing data quality and reliability. In fact, most miniaturized sensors do not provide at the same time both a local memory for data storage and a wireless link for data transmission. The proposed node architecture instead, stores all the measurements in its local memory avoiding any possible data loss in case of failure in the wireless link or in the Internet connection. Connection failures can occur frequently in cultural heritage sites where the power supply could not be always available or the Internet link could be unreliable and slow. Some miniaturized data-logger commercially available embed a local memory, but usually its capacity is limited to few thousands of measurements. As an example, the *Thermochron/Hygrochron iButton* [21], produced by *Maxim Integrated*, provides a storage capacity of only 2048 measurements, and the tiny data-logger *MicroT* [22], by *Phase IV Engineering Inc.*, allows storing no more than 4000 measurements. Other similar data loggers are the *MicroLog Pro II* [23] and the *OM-90* [24]. However, none of these systems implement a long-range wireless data link and all require users to actively operate to download measurement data.

The memory embedded in the node described in this work has been selected to store about 125000 measurements and this capacity is enough for logging data at intervals of 15 min along the whole operative life of the sensor (more than 3 years). In addition, several other features contribute to the functionality and novelty of the proposed system. In particular:

- long operative life without any required attendance;
- no cabling for node placement and wide wireless range;
- flexibility in the deployment, management and operation;
- capability of working also in absence of power supply or Internet connection;
- on-board backup non-volatile memory avoid any possible data loss;
- data quality assured by calibration;
- local and remote data access and control using the extensive cloud infrastructure and μ Panel architecture;
- low cost, small size and minimal invasiveness.

Several monitoring system have been described in the literature and are available on the market [21–24], which feature some of the above mentioned functionalities, but none of them seems to embed all the features in a single device with dimensions smaller than 4 cm. The proposed system instead has been designed trying to obtain an optimal trade-off of all constraints and functionalities in order to make it almost unique and novel.

The sensors employed on the nodes are directly responsible of the metrological performance of the whole monitoring network. The node hardware can be easily adapted to virtually any kind of low-power sensors in order to fit the specific monitoring application at the only cost of an increased size and/or reduced operative life.

The default communication protocol used by the nodes is the BT-LE that provides wide wireless range, low power consumption and good data transmission rate. The BT-LE

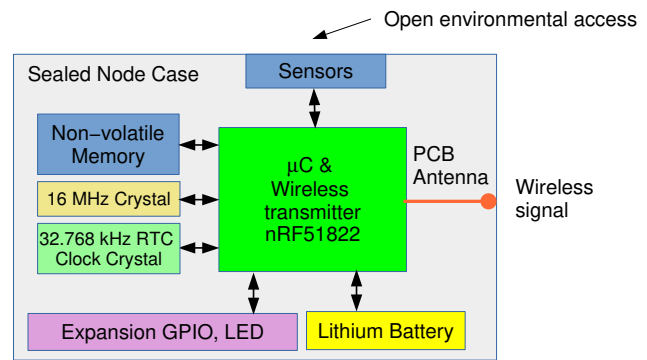

Fig. 2. Block diagram of the realized sensor node

features are used to allow an easy implementation of a star topology monitoring network, which has been chosen in order to optimize the node power consumption. Other network topologies, as the mesh networks, usually involve the routing of data packets from a node to another and consequently the operative life of each node is significantly reduced. Even though the proposed star approach requires to increase the number of wireless receivers to monitor large sites, it should be considered that the receivers are very small and cheap. In addition, BT-LE is largely compatible with almost all low-cost embedded PC and all modern smart-phones, and this simplifies the development of the receivers themselves and the local data access in the monitored location. Nevertheless, it is always possible to employ different proprietary communication protocols working on the Industrial, Scientific and Medical (ISM) band of 2.4 GHz using the same hardware and the same data infrastructure [17].

A. The node architecture

The block diagram of the sensing node architecture is shown in Fig. 2. The figure shows:

- The node core based on the System-on-Chip (SoC) nRF51822, manufactured by *Nordic Semiconductor*. This chip integrates a 32-bits ARM-M0 microcontroller, a low-power 2.4 GHz transceiver and a large set of peripherals including an analog-to-digital converter which can be useful for interfacing analog sensors.
- The non-volatile flash memory W25X40CL manufactured by *Winbond*, which is connected to the microcontroller via the Serial Peripheral Interface (SPI). The memory is powered on-demand in order to reduce the power consumption and provides the node with a 4 Mbit on-board memory for measurement data storage.
- The Lithium battery, directly soldered to the Printed Circuit Board (PCB) to power the node for its entire operative life.
- The antenna for the wireless communication between node and receiver.

The nodes employ a common folded antenna described in several BLE reference designs (see as an example [25, 26]). The antenna is implemented directly on the PCB with a properly-shaped metal trace tuned at the

frequency of 2.4 GHz. The antenna is connected to the nRF51822 SoC through an impedance adapter (balun) and a matching network. This solution allows achieving a good trade-off between PCB size and efficiency, with a very low cost.

- The sensor, that physically performs the measurements. The type and the performance of the sensor can be selected in order to address the requirements of the specific monitoring application and may also include a proper interfacing circuitry.
- The 16 MHz crystal that generates the main clock for the microcontroller.
- The 32.768 kHz crystal that generates the clock for the microcontroller Real-Time-Clock (RTC).
- Some auxiliary microcontroller lines useful for expanding the node capabilities, and a small LED used for signaling specific conditions.

The developed node used to arrange the network described in this paper, employs the digital sensor SHT21 by *Sensirion*, able to measure temperature and relative humidity with typical uncertainties of $\pm 0.3\text{ }^{\circ}\text{C}$ and $\pm 2\text{ \%RH}$ (in the range from 20 %RH to 80 %RH), respectively. This sensor guarantees a low power consumption and a very good measurement resolution (0.01° for temperature and 0.04 \%RH for humidity). Moreover, the power consumption decreases to about 150 nA in sleep mode, so the sensor can be always powered.

Fig. 3 shows the node prototype in its 3D-printed custom case, which can be realized in different shapes and colors as to satisfy environmental and aesthetic requirements. The main electronic components of the circuit are visible, too. The sealed case has a grid of holes in correspondence to the SHT21 sensor position to guarantee, at the same time, a good air-flow to the sensor and a tampering-safe operation.

The transceiver integrated on the nRF51822 SoC is especially suitable for BT-LE, but it can be also employed to arrange other proprietary protocols working on the ISM band of 2.4 GHz. It provides an output power ranging from -30 dBm to 4 dBm , which can be selected via software, and exhibits a receiver sensitivity of -93 dBm . These features can be used to optimize the power consumption of the node depending on the environment and on the presence of obstacles. The wireless operative range can go from 10 m to more than 30 m. Several BT-LE stacks are available from *Nordic Semiconductor* with the name of “SoftDevices”. These stacks implement all the BT-LE basic protocol and firmware interfaces to the transceiver hardware through a callback scheme.

The SoC clock is generated using two different crystals. A 16 MHz crystal is used for the main clock and for synthesizing the BT-LE radio frequency, while a 32.768 kHz crystal is used by the RTC. This is programmed to wake up the microcontroller for performing measurements at specified time intervals which can be selected from 1 s to some hours. So, it is possible to leave the microcontroller in sleep mode for most of the time reducing power consumption and, at the same time, providing a good accuracy for the measurement time.

A LED is present on-board for giving general indications to the users. In addition, 12 lines from the microcontroller (general purpose IO, analog lines and peripherals) are available

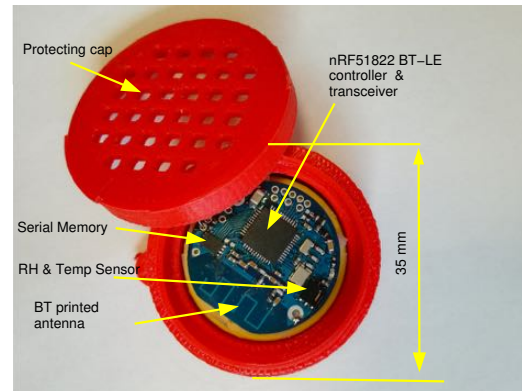

Fig. 3. Picture of one node prototype designed to measure temperature and relative humidity. The node employs the BT-LE protocol to connect to the receivers.

at pads on the PCB side, giving the possibility to connect either small extension boards or supplementary circuitry to the node without changing the hardware design.

The node is powered by a CR2477 lithium battery, which has a nominal capacity of 1 Ah. The power consumption measurements described in section III-B3 show that with this battery it is possible to measure temperature and humidity every 15 mins for more than three years. Smaller batteries can be employed to reduce the node size, but of course reducing the node life time. As an example, the CR2032 battery with a capacity of 225 mAh can power the node for about one year with the same measurement setup.

The PCB has a circular shape with a diameter of 22 mm and a thickness of about 3.6 mm (including components). It is realized using a standard low-cost FR4 substrate and a double layer technology with components placed on the top side only. By using this design, the node is capable of working without any attendance for years, can be freely installed in the monitored location without any cable, it is very small and have a minimal visual impact.

B. Node performance

1) *Measurement uncertainty*: As told in the previous paragraph, the nodes employ as the main sensor an SHT21 which is factory calibrated in order to automatically compensate for different sensitivities of the sensing elements. Since the calibration deals only with the sensor and not with the entire system, the authors tested each device in a climatic chamber to assess both the actual uncertainty and the possible effects of the 3D case. The performance has been tested by inserting nodes and a calibrated thermo hygrometer inside a ventilated climatic chamber at a temperature of about $25\text{ }^{\circ}\text{C}$. The standard uncertainty of the calibrated hygrometer is of the order of $U_{RH} = 0.8\%$. The calibration has been performed in the humidity range of 20% to 80% obtaining a difference between node output and calibrated values below $\Delta_{RH} = 2\%$ as expected. The presence of the 3D case did not affect the node outputs, but slowed down the node response. Thus a specific additional test was performed.

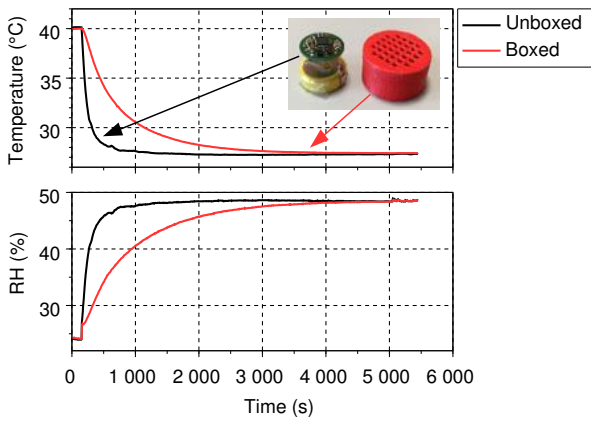

Fig. 4. Time response of the described nodes with and without the 3D box used to protect the node.

2) *Response time*: The response time of the SHT21 is declared to be of about 8 s, but this value is obtained in air which moves at the speed of 1 m/s. Since the nodes typical use is in still air and the sensor is shielded by the 3D box, a test has been performed to assess the response in these conditions. Fig. 4 shows the response of two different nodes: one enclosed into the 3D box and another, arranged for the test, without 3D box and with the PCB allocated far from the battery.

In this case the test has been performed by putting the nodes inside the climatic chamber set at about 40 °C and 25 %RH until the node outputs stabilize and then abruptly moving the nodes outside the chamber where the temperature is at about 25 °C and the humidity is of about 45 %RH. This assures the nodes are subjected to an environment change which is much faster than the expected sensor response and that after the movement the nodes remain in a nominally still air.

Fig. 4 shows the outputs of the two nodes: it is easy to observe how both nodes are rather slower than the sensor specifications in moving air at 1 m/s. The node without box has time constants of the order of 130 s while the 3D case presence increases the time constants to about 700 s. These values are much higher than the stated sensor values, but still short in comparison to the expected speed of variation of the environment in the cultural heritage field. In addition, the test shows how the final values, when the transient finishes, are not affected by the 3D box presence as expected.

3) *Power requirement*: The node power requirement could be easily estimated by measuring the absorbed current. Unfortunately, the nodes remain most of the time in sleep mode, thus absorbing a current of few micro amperes. When the nodes awake for measuring and transmitting, the current increases up to 20 mA for time intervals of the order of few microseconds. Measuring such a large change and correctly integrating the current to estimate the average power requirement is rather difficult, thus the authors decided to employ an indirect solution based on a physical current integration by using the simple circuit shown in fig 5-A. When the switch is opened, the current can be estimated monitoring the voltage across the

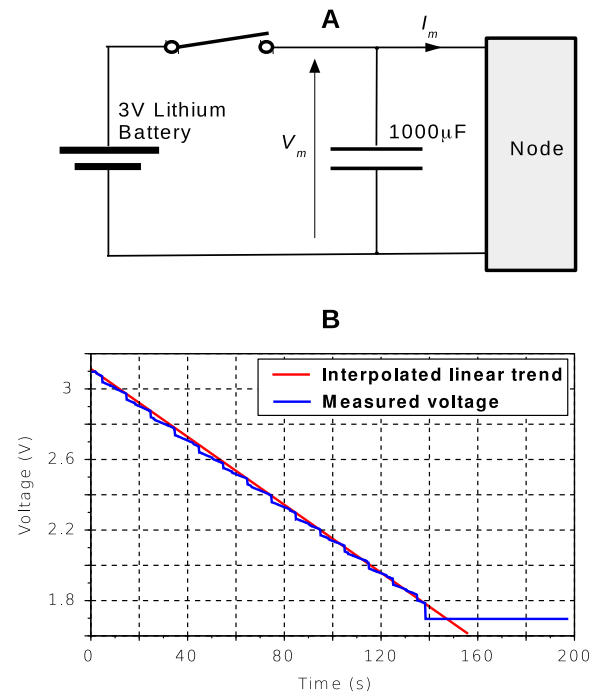

Fig. 5. A) Circuit used for estimating the current consumption; B) measured voltage during an operation till the node stops working.

capacitor which discharges according to eqn. 1:

$$V_m = V_b - \int_0^t \frac{I_m(t)}{C} dt \quad (1)$$

where V_m is the voltage value measured by an oscilloscope, V_b is the initial battery voltage, of the order of 3 V, C is the capacitor value, and I_m is the unknown current.

The measurement can be performed only for a short period of time, to avoid the capacitor to discharge below the minimum node operating voltage, which is of the order of 2.0 V, and to avoid significant current changes with the supply voltage. For this reason a preliminary characterization has been performed by acquiring the capacitor voltage until its value drops below the minimum operating voltage. Fig. 5-B shows that the current is only rather marginally affected by the actual supply voltage and that the minimum operating voltage is below 1.8 V. With these values time observations of the order of 60 s can easily be obtained and the current peaks, which are correctly integrated, can be estimated by the voltage changes.

Fig. 6 shows an example of trace obtained by using the node to perform the basic different operations, i.e. measuring, advertising, and operating in connected mode. The inset shows, the complex shape of the instantaneous current measured on a sense resistor during a node advertisement: the BT-LE protocol employs an advertisement on three different radio channels and this accounts for the three peaks.

From the traces it is easy to estimate that the charge per advertisement Q_{adv} is of about 34 μC , the charge per measurement Q_m is of about 41 μC , the charge for each connect operation (connect+disconnect) is of about 480 μC

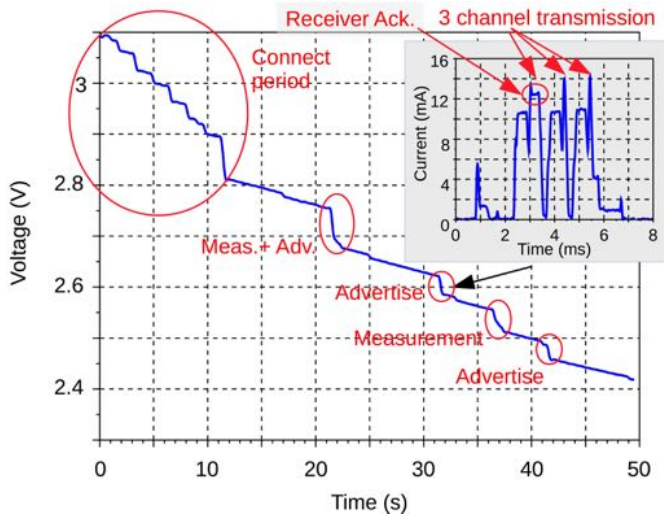

Fig. 6. Traces showing the power consumption obtained by using the circuit described. At the end of the connect period the sensor was configured to advertise every 10 s and to measure every 15 s.

plus a current during the connect time which is of about $20 \mu\text{A}$, while the idle node current I_{idle} is of about $5.7 \mu\text{A}$.

The charge required per hour Q_h in normal operations, i.e. in the absence of connect requests, can therefore be obtained as:

$$Q_h = Q_{adv}A_h + Q_mM_h + 3600 \cdot I_{idle} \quad (2)$$

where A_h and M_h are the number of advertisements and measurements per hour.

By performing a measurement every 15 min and an advertisement every 10 s to have a quickly answering node, the charge per hour is of about $Q_h = 0.03 \text{ C}$. This corresponds, using a battery of 1 Ah, to a theoretical duration of more than twelve years. Estimating a reasonable connection frequency and reasonable connection time is quite difficult as these values strongly depend on the actual operations, however a worst estimation could be obtained with a continuous connection, which corresponds to a charge requirement of about 0.07 C per hour. With the same battery, this corresponds to more than five years of node operation. Of course the real operative life is lower than these values, as the battery self-discharge and the possible battery capacity reduction due low temperatures are not taken into account, nevertheless a life in excess of three years is expected.

C. The communication protocol

The RTC wakes up the node periodically in order to perform the measurements. All results are stored inside the non-volatile memory and sent to a receiver. In the case a compatible receiver is in the transmission range, it responds to the node with a *scan request*, that is used as a sort of acknowledge. If the receiver UID is recognized, the node marks the data as *received* but avoid sending any *scan response* in order to reduce power consumption. If no receiver responds to the node *advertising*, the node continues performing the

measurements as set, storing their values inside its memory as *non-received*. When a recognized receiver acknowledges the node *advertising*, the node starts sending alternately the last measurement and the old ones until all data in the memory are marked as *received*.

The use of the BT-LE *advertising mode* as the main communication mode has several advantages. In fact, this way it is possible to send the last collected measurements¹ with a minimal power consumption and a large data redundancy. In addition, the packets transmitted over BT-LE can be received virtually by any compatible device, like common smart-phones. The BT-LE reduces the data latency to few seconds instead of several minutes as in the previous implementation [17] still maintaining the same low power consumption. Moreover, it should be pointed out that the presence of a large number of receivers in the monitored site (i.e. the smart-phones of visitors in museums) does not affect the power consumption because the energy required in *advertising mode* is almost independent from the number of receivers.

In order to avoid the disclosure of sensible data to unauthorized people it is possible to encrypt transmitted data. In addition, it is possible to set the node to connect only to specific UIDs with a further reduction of the power consumption. The authorized receivers can connect and use a normal transfer communication in order to either quickly retrieve data or reconfigure the sensor node.

IV. THE RECEIVERS

The fig. 1 shows the two main ways a generic user can employ for receiving data from the nodes: a dedicated BT-LE wireless receiver connected to the Internet, and a compatible smart-phone taken close to the nodes.

A. Dedicated BT-LE Receiver

This type of receiver can be employed when the monitored location is provided with a power supply and an Internet connection (e.g. a WiFi Network). In this situation, the receiver stays always connected to the Internet waiting for the sensor data. When a new measurement is available, it gets such measurement and pushes it on the cloud infrastructure. This allows either a real-time or a quasi real-time monitoring of the location with data available worldwide. If an Internet connection problem occurs preventing the receiver to access the Internet, the receiver is able to temporarily store measurements inside a dedicated buffer, waiting for pushing them on the cloud as soon as the Internet connection is again available. The possibility of short power blackouts is managed by providing the receiver with a backup battery that can power the system up to few days. If the power absence lasts longer, the receiver shuts down. Nevertheless, measurements are anyway stored on node memories, so they can be retrieved either directly or upon a cloud request, without any loss.

One possible implementation of such receiver is shown in Fig. 7. The receiver is entirely implemented using the RaspberryPI Zero W, a very small and cheap computer on

¹Up to four measurements fit into the implemented advertising packet

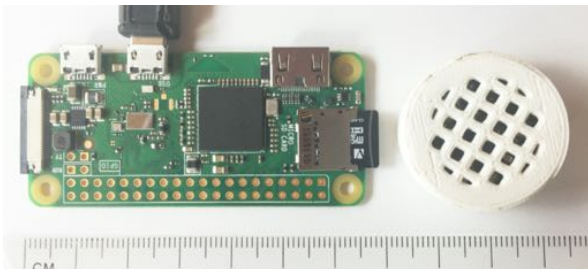

Fig. 7. Picture of the prototype receiver for real-time monitoring employing the RaspberryPI Zero W board. For comparison the picture also shows a prototype of a sensing node.

single board. RaspberryPI features a 32-bit 1 GHz ARM11 processor, 512 MBytes of RAM and a miniHDMI Interface on a board whose dimensions are 65 mm x 30 mm x 5 mm. Furthermore, the board supports natively the connectivity for both WiFi and Bluetooth Low-Energy, and this fits perfectly with the requirements of the proposed monitoring network because the board can interface without any additional circuitry both the sensor nodes and the Internet. Its power consumption is quite moderate, consuming a current of about 200 mA from a standard 5 V power supply. The board is able to run high-level operating systems like many releases of the Linux Kernel and this greatly simplifies the software development, being the most of the services already implemented in the OS. The high computing capability of the processor also gives the possibility to add extra functionalities to the receiver. As an example, a real-time analysis of the data can be performed in-situ and a warning or alarm can be generated when unsafe conditions are reached in the location.

In addition to the cloud pushing functionality, the dedicated BT-LE receiver can be equipped with the μ Panel capability [18] to enable a simpler client use. The μ Panel environment is a commercial infrastructure that permits developers to interface simple systems to almost any smart phone without the need to develop any App and any complex Internet protocol. The μ Panel software encodes data and rules for arranging the Graphical User Interface (GUI) using the HCTML (Hyper Compact Text Markup Language) [18] which is very suitable also for slow or unreliable Internet connections.

B. Smart-phone-based local receiver

Since the sensor nodes employ the BT-LE communication protocol, any device provided with a BT-LE connectivity can receive measurement data from the nodes. As an example, most smart-phones and portable PCs can be used to receive such data and if a dedicated app is developed, basic functionalities of the monitoring network like local access to the sensor data, configuration and control of the network itself can be easily implemented. This can be very useful for the staff working at the monitored location because they can locally access the monitoring network even when there is no Internet connection or the receivers are not operative for any reasons.

V. NETWORK CLIENTS

A. The Real-Time Control Client

A real-time control client can be easily arranged by using the μ Panel architecture and has the capability of displaying data and controlling both the receivers and the sensor nodes.

The installation of the μ Panel App on the smart-phone makes it ready to locally connect with the monitoring network using the WiFi obtaining simple visualizations like the one shown in the following section. In addition, if the receiver is capable of connecting to the Internet to contact the cloud, the real-time client is able to reach the receiver via cloud without being necessarily on site. In this case the cloud acts as the bridge between the smart-phone and the receiver so that a real-time control of a specific site can be achieved worldwide.

B. Off-line Clients

Data transmitted by the nodes and uploaded to the cloud database can also be accessed by clients designed to work with the stored data. The cloud database organizes all the data and TEDSs of the sensor nodes according to their IDs, and uses calibration TEDSs for correcting data.

In the simplest fashion, the off-line client can be a browser so that no software has to be developed: the Web Server Data Manager reported in fig. 1 provides a simple interface where users can select the sensors and the time interval, see the measurements and download them. The Web Server is configured to validate any user to check if he/she is authorized to see the data and this prevents unauthorized users to access sensitive data.

If this simple interface is not enough for the user requirements, users can directly access the database to process all measurements according to any specific requirement. This of course requires developing a specific *downloader* program, but lets users free to arrange the access according to their specific needs as shown in the following section.

VI. EXAMPLE OF NETWORK USE

The proposed wireless sensor network has been deployed in several sites, to monitor the environment changes over time. Data reported in this section refer to a building located in the north of Italy, which is going to be restored. A request to monitor the environmental conditions before and after the restoration has been set to help restorers to arrange the system and to see if anything was correctly performed. In this case six nodes have been positioned in different points of the large (20 m x 20 m) room to be restored and a receiver has been positioned in a corner where the power supply was available along with an Internet access. The solution permits to employ an on-line receiver so that a real-time monitoring is available and also the off-line clients can be used.

Fig. 8 shows an example of screen shots taken on a smart-phone running the μ Panel App used to monitor and control in real-time the sensors inside the building. Enabled users can follow what happens in the building connecting either directly to the receivers or through the cloud from any location.

As an example, fig. 9 shows the measurements as obtained by a simple data downloader, but selecting only some sensors

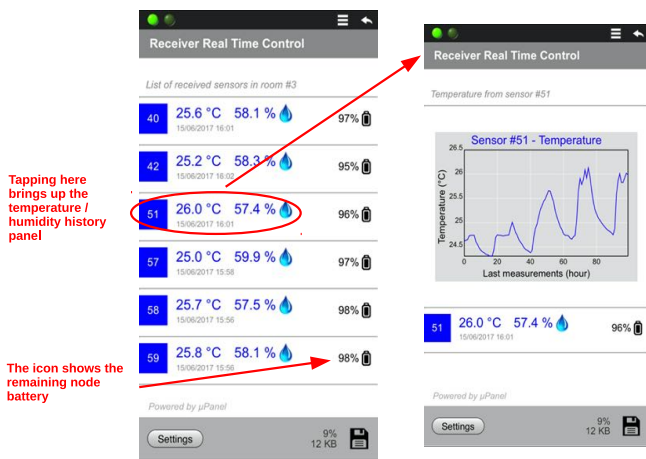

Fig. 8. Pictures of the panels of the virtual App displayed on a smart-phone, generated and sent by the on-line receiver by using the μ Panel technology. The panels permit to monitor and control the receivers in real-time from the smart-phone, locally or via Internet.

and expanding specific time intervals. Node #42 is positioned close to the entrance, node #57 at an height of about 3 m, nodes #58 and #59 are positioned close to two windows. The large difference in temperature and humidity is clearly visible suggesting restorers to pay specific attention to the environment close to the windows.

During July and August power and Internet were unavailable due to a building closure and the on-line system stopped working. However, the system correctly recovered the measurements on Aug. 28 when the power was restored, proving the resiliency of the proposed solution.

VII. CONCLUSIONS

Environmental monitoring is a tricky activity as the environmental conditions can easily change from point to point even at small distances. This is especially true inside buildings where temperature, humidity and pollutants can be different not only in different rooms, but also within the same room especially when showcases and closed furniture are used. While several architectures have been proposed that can manage many sensing nodes, often there is a low attention to the assurance of the quality of measured values. The components developed within the framework described in this paper try to address this aspect by using a multi-layer data storage system with battery operated sensors equipped with a local non-volatile memory and a transmission protocol, which ensure the measured data permanence even in the case of network failure. Such a local memory also enables using the nodes in locations where no network connection is available like basements and or unattended remote sites.

All nodes have a unique identifier and are designed to work for years without manual intervention. All measurements are permanently stored inside the node and can be altered only by tampering the sensor and breaking its case. Under normal conditions buffered receivers and a distributed cloud storage can deliver the measurements to the users in either real-time

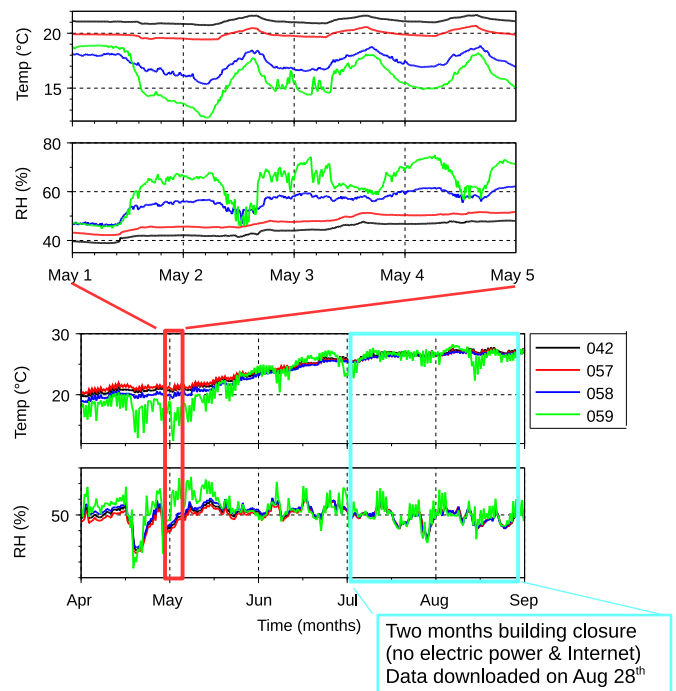

Fig. 9. Data measured in an heritage building in north of Italy before its restoration and conditioning as obtained by a user downloader. The picture shows the results of 4 nodes over two months and an expansion over 5 days. Node #42 is positioned close to the entrance, node #57 at about 3 m height, nodes #58 and #59 are positioned close to two windows. The large difference in temperature and humidity is clearly visible. .

or quasi real-time, but there is the assurance raw measured data are always retrievable.

Moreover, the nodes can be calibrated by comparing their output with respect to standard sensors and a TEDS is associated to each unique identifier and stored in the cloud so that all measurements can be processed before being sent to the user, but anyway the unprocessed data can always be accessed.

Authorized users can access all measurements by means of a pc without installing any software and by means of a smart phone to follow the environment evolution in real time from anywhere. They can also query the database by using a specific client to perform further data processing.

The use of a BT-LE protocol for the transmission between nodes and receivers gives the possibility of having an extremely long node life, which can be of up to 3 years, in the case of simple measurements like temperature and humidity.

The proposed architecture has been deployed in several heritage buildings and museums and is producing measurements since 2015 with about 50 nodes already installed.

REFERENCES

- [1] M. F. Gard, "A status report on environmental monitoring", *IEEE Transactions on Instrumentation and Measurement*, vol. 51, no. 2 pp. 782-785, 2002
- [2] A. Kumar; H. Kim; G. P. Hancke, "Environmental Monitoring Systems: A Review", *IEEE Sensors Journal*, vol. 13, no. 4, pp. 1329-1339, 2013

- [3] N. Kularatna, B. H. Sudantha “An Environmental Air Pollution Monitoring System Based on the IEEE 1451 Standard for Low Cost Requirements”, IEEE Sensors Journal, vol. 8, no. 4, pp. 415-422, 2008
- [4] A. Kumar, I. P. Singh; S. K. Sud, “Energy Efficient and Low-Cost Indoor Environment Monitoring System Based on the IEEE 1451 Standard”, IEEE Sensors Journal, vol. 11, no. 10, pp. 2598-2610, 2011
- [5] G. Mois, T. Sanislav, S. C. Folea, “A Cyber-Physical System for Environmental Monitoring”, IEEE Transactions on Instrumentation and Measurement, vol. 65, no. 6, pp. 1463-1471, 2016
- [6] M. T. Lazarescu “Design of a WSN Platform for Long-Term Environmental Monitoring for IoT Applications”, IEEE Journal on Emerging and Selected Topics in Circuits and Systems, v ol. 3, no. 1, pp. 45-54, 2013
- [7] C. M. Grzywacz, “Monitoring for Gaseous Pollutants in Museum Environments”, The Getty Conservation Institute, 2006, available at http://www.getty.edu/conservation/publications_resources/pdf_publications/pdf/monitoring.pdf, last checked 2015, Sept. 20.
- [8] D. Camuffo et. al, “Environmental monitoring in four European museums”, Atmospheric Environment, Vol.35, supp.1, 2001, pp. S127-S140
- [9] S. Corbellini; M. Parvis; S. Grassini; L. Benussi; S. Bianco; S. Colafranceschi; D. Piccolo; “Modified POF sensor for gaseous hydrogen fluoride monitoring in the presence of ionizing radiations”, IEEE Transactions on Instrumentation and Measurement, Vol. 61, Issue 5, 2012, pp. 1201-1208.
- [10] J. Schmalzel; F. Figueroa; J. Morris; S. Mandayam; R. Polikar, “An architecture for intelligent systems based on smart sensors”, IEEE Tr. on Instrumentation and Measurement, vol. 54, no. 4, pp. 1612-1616, 2005
- [11] A. Carullo; S. Corbellini; F. Ferraris; M. Parvis; A. Vallan, “Integration of low computational power nodes in a GRID measurement architecture”, IEEE Instrumentation and Measurement Technology Conference IMTC 2007, pp. 1-5, 2007
- [12] A. Flammini; D. Marioli; E. Sisinni; A. Taroni, “Environmental Telemonitoring: A Flexible GSM-DECT-Based Solution”, IEEE Transactions on Instrumentation and Measurement, vol 56, no. 5, pp. 1688-1693, 2007
- [13] B. Gedik; L. Liu, “A scalable peer-to-peer architecture for distributed information monitoring applications”, IEEE Tr. on Computers, vol. 54, no. 6, pp. 767-782, 2005
- [14] G. Zhongwen, et al, “IMA: An Integrated Monitoring Architecture With Sensor Networks”, IEEE Tr. on Instrumentation and Measurement, vol. 61, no.5 pp. 1287-1295, 2012
- [15] S. Corbellini, M. Parvis “Wireless Sensor Network Architecture for Remote Non-invasive Museum Monitoring”, Proceedings of the 2016 International Symposium on System Engineering ISSE 2016, Edinburgh, UK, Oct. 3-5, 2016, pp. 34-40
- [16] S. Corbellini; F. Ferraris; M. Parvis, “A system for monitoring workers’ safety in an unhealthy environment by means of wearable sensors”, IEEE Instrumentation and Measurement Technology Conference IMTC 2008, pp. 951-955, 2008
- [17] S. Grassini, E. Angelini, A. Elsayed, S. Corbellini, L. Lombardo, M. Parvis “Cloud Infrastructure for Museum Environmental Monitoring”, Proceedings of I2MTC 2017, pp. 1840, 1845.
- [18] The μ Panel system. Available at <http://miupanel.com>, last checked 2017, Aug 1.
- [19] National Park Service: “Comparing Temperature and Relative Humidity Dataloggers for Museum Monitoring” Conserve O Gram Series, N.3/3 Sept. 2011, available at <http://www.nps.gov/museum/publications/consveogram/03-03.pdf>, last checked 2015, Sept. 20
- [20] Testo Saveris - Available at https://www.testo.com/en-US /Target-groups /Industry/Industry—Museums-and-Archives /c/target_groups_industry_museums_archives last checked 2016, Oct. 25
- [21] The iButton. Available at <https://www.maximintegrated.com/ en/ products/ ibutton/ ibuttons/ thermochron.cfm> , last checked 2017, Oct. .
- [22] The Micro-T data logger. Available at <http://www.phaseivengr.com/ wireless-technologies/ about-rfid-wireless-data-loggers/ about-hf-nfc-rfid-wireless-data-loggers/> , last checked 2017, Oct, 20.
- [23] The MicroLog Pro II data logger. Available at [http:// fourtec.com/ Products/ 55/67/ MicroLogPRO-II-Temperature-and-Humidity-Logger/](http://fourtec.com/ Products/ 55/67/ MicroLogPRO-II-Temperature-and-Humidity-Logger/) , last checked 2017, Oct, 20.
- [24] The OM-90 data logger. Available at [https:// it.omega.com/pptst/ OM-90_SERIES.html](https://it.omega.com/pptst/ OM-90_SERIES.html) , last checked 2017, Oct, 20.
- [25] The nRF Dongle Reference Design from Nordic Semiconductor. Available at <https:// www.nordicsemi.com/ eng/ Products/ nRF51-Dongle>, last checked 2017, Oct, 20.
- [26] AN11994 QN908x BLE Antenna Design Guide from NXP Semiconductos. Available at <https:// www.nxp.com/ docs/en/ nxp/ application-notes/ AN11994.pdf>, last checked 2017, Oct, 23.



Luca Lombardo was born in Italy in 1986. He received his B.D. and M.S. degree in electronic engineering from the Università di Messina, Italy, in 2014 and 2016, respectively. Currently he is a PhD Student in Metrology with the Dipartimento di Elettronica e Telecomunicazioni, Politecnico di Torino. His research interests include the development of innovative sensors and systems especially for environmental monitoring and biomedical applications, embedded systems and instrumentation in general.



Simone Corbellini was born in Italy in 1977. He received the M.S. degree in Electronic Engineering in 2002 from Politecnico di Torino, Italy, and the Ph.D. degree in metrology in 2006 from Politecnico di Torino, Italy. His main fields of interest are digital signal processing, distributed measurement systems, and intelligent microcontroller-based instrumentation. At present, he is working on the development of networks of low-power wireless sensor for environmental, biomedical and chemical quantities.



Emma Angelini was born in Torino in 1951, was graduated in Chemistry at Torino University. She is in Politecnico di Torino since 1976 and is now Full Professor of Applied Physical Chemistry in the Faculty of Engineering, Information Sector. Her research areas are: Corrosion and protection of metallic materials, as stainless steels, amorphous and nanocrystalline alloys, biomaterials for dentistry, tangible Cultural Heritage; plasma chemistry and coatings deposition. She is involved in National and European projects on corrosion and protection of metals and is member of the European Federation of Corrosion (EFC).



Marco Parvis was born in Italy in 1958. He received his MS degree in electrical engineering in 1982 from the Politecnico di Torino, Italy, and a Ph.D. degree in Metrology in 1987. He is now full professor of Electronic Measurements at the Politecnico di Torino, where he was Dean of the II Faculty of Engineering, and Fellow Member and chair of the TC 25 Medical Measurement of the IEEE Society on Instrumentation and Measurement. His main fields of interest are: intelligent instrumentation, application of signal processing to measurement, biomedical and

chemical measurements. He is author of more than one hundred publications.



Ahmed Elsayed was born in Egypt in 1984. He received his M. S. in restoration and conservation of metallic monuments from the Sohag University, Egypt in 2013 and is now attending a Ph.D. program in materials science in Politecnico di Torino, Italy since 2015. He is currently an Assistant Lecturer in restoration and conservation department, Faculty of Archaeology, Sohag university, Egypt. His research areas include plasma uses in conservation, coating deposition, corrosion and protection of metallic materials, and conservation of the cultural heritage.



Sabrina Grassini was born in Italy in 1972. She received her M.S. degree in Chemistry in 1999 from the Università di Torino, Italy, and her Ph.D. degree in Metallurgical Engineering in 2004 from Politecnico di Torino, Italy. Currently she is an associate professor of Applied Physical Chemistry with the Dipartimento di Scienza Applicata e Tecnologia, Politecnico di Torino. Her researcher areas include plasma chemistry, coating deposition, sensors, corrosion and protection of metallic materials, and conservation of cultural heritage.