

Massively Extended Modular Monitoring and a Second Life for Upper Stages

*Original*

Massively Extended Modular Monitoring and a Second Life for Upper Stages / Meß, Jan-Gerd; Sonza Reorda, Matteo; Violante, Massimo; Dannemann, Frak; Hanson, Berenike; Söderholm, Stefan; Karlsson, Niklas; Kuremyr, Tobias; Albert, Yann; Spiecker, Joachim. - STAMPA. - (2018). (Intervento presentato al convegno 69th International Astronautical Congress(IAC), Bremen, Germany, 1-5 October 2018. tenutosi a Bremen, Germany, 1-5 October 2018. nel 1-5 October 2018.).

*Availability:*

This version is available at: 11583/2753653 since: 2019-09-21T18:01:08Z

*Publisher:*

International Astronautical Federation

*Published*

DOI:

*Terms of use:*

This article is made available under terms and conditions as specified in the corresponding bibliographic description in the repository

*Publisher copyright*

(Article begins on next page)

## Massively Extended Modular Monitoring and a Second Life for Upper Stages

Jan-Gerd Meß<sup>a\*</sup>, Matteo Sonza Reorda<sup>b</sup>, Massimo Violante<sup>b</sup>, Frank Dannemann<sup>a</sup>, Berenike Hanson<sup>c</sup>,  
Niklas Karlsson<sup>c</sup>, Tobias Kuremyr<sup>c</sup>, Stefan Söderholm<sup>c</sup>, Yann Albert<sup>d</sup>, Joachim Spiecker<sup>d</sup>, Görschwin Fey<sup>e</sup>

<sup>a</sup> German Aerospace Center (DLR), Institute of Space Systems, Robert-Hooke-Str. 7, Bremen, Germany,  
[jan-gerd.mess, frank.dannemann]@dlr.de

<sup>b</sup> Politecnico di Torino, Corso Duca degli Abruzzi 24, 10129 Torino, Italy, [matteo.sonzareorda,  
massimo.violante]@polito.it

<sup>c</sup> AAC Microtec AB, Dag Hammarskjölds väg 48, 751 83 Uppsala, Sweden,  
[berenike.hanson, niklas.karlsson, tobias.kuremyr, stefan.soderholm]@aacmicrotec.com

<sup>d</sup> ArianeGroup, Airbus-Allee 1, 28199 Bremen, Germany, [yann.albert, joachim.spiecker]@ariane.group  
<sup>e</sup> Hamburg University of Technology, Am Schwarzenberg-Campus 1, 21073 Hamburg, Germany,  
goerschwin.fey@tuhh.de

\* Corresponding Author

### Abstract

Launching science and technology experiments to space is expensive. Although commercial spaceflight has resulted in a drop of prices, the cost for a launch is still significant. However, most of the weight that is needed to conduct experiments in space belongs to the spacecraft's bus and it is responsible for power distribution, thermal management, orbital control and communications. An upper stage, on the other hand, includes all the necessary subsystems and has to be launched in any case. Many upper stages (e.g. ARIANE5) will even stay in orbit for several years after their nominal mission with all their subsystems intact but passivated.

We propose a compact system based on a protective container and high-performance Commercial-off-the-Shelf (COTS) hardware that allows cost-efficient launching of technology experiments by reusing the launcher's upper stage and its subsystems. Adding acquisition channels for various sensors gives the launch provider the ability to exploit the computational power of the COTS hardware during the nominal mission. In contrast to existing systems, intelligent and mission-dependent data selection and compression can be applied to the sensor data.

In this paper, we demonstrate the implementation and qualification of a payload bus system based on COTS components that is minimally invasive to the launcher (ARIANE5) and its nominal mission while offering computational power to both the launch provider and a potential payload user. The reliability of the COTS-based system is improved by radiation hardening techniques and software-based self-test detecting and counteracting faults during the mission.

**Keywords:** Monitoring, ARIANE5, COTS, Protective Container, Data Compression, Software-based Self-Test

### Acronyms/Abbreviations

- Acquisition Board (AQB)
- Attitude and Orbit Control System (AOCS)
- Board Support Package (BSP)
- Commercial-off-the-Shelf (COTS)
- Data Handling System (DHS)
- Discrete Wavelet Transform (DWT)
- Field Programmable Gate Array (FPGA)
- Geostationary Transfer Orbit (GTO)
- Intellectual Property (IP)
- Latching Current Limiters (LCL)
- Massively Extended Modular Monitoring for Upper Stages (MaMMoTH-Up)
- No List Set Partitioning in Hierarchical Trees (NLS)
- On-Board Computer (OBC)
- Power Supply Unit (PSU)

- Pulse per Second (PPS)
- Small and Medium-sized Enterprise (SME)
- Software-based Self-Test (SBST)

### 1. Introduction

Traditionally, in the space industry, there is a clear distinction between launch provider and payload manufacturer. While this distinction makes sense from an organizational and product point of view, it yields room for optimization regarding the subsystems of both the launcher and its payloads. Specifically, many subsystems such as radio link, power supply and structure are needed by the launcher as well as its payload. For the launcher, however, these components, although fully functional, are passivated and become space debris right after the fulfilment of the nominal mission.

In order to fully exploit every kilogram of expensive equipment launched to space, we propose to reuse these components and offer them as a basis for small short-term payloads or technology experiments. This could significantly decrease the cost of technology experiments, because many of the otherwise mandatory subsystems are already in orbit. Of course, this reuse requires certain adaptations of the launcher's on-board system. In order to be minimally invasive towards existing systems, we also propose a COTS-based system in a protective container that serves as payload bus between launcher and payload.

To justify the extra weight of this system, acquisition channels for various sensors can be added. This gives the launch provider the ability to flexibly place additional sensors on its launcher providing deeper insight into its mechanical stress and environmental conditions. The payload bus can be used to acquire valuable data during the launcher's nominal mission. Exploiting the computational power of the COTS hardware, intelligent and mission-dependent data selection and compression are applied to the sensor data. This enables a high information throughput even at low data rates that can be integrated in the existing launcher telemetry providing a substantial benefit to the launch provider.

In this paper, we describe the dual mission concept of inhaling a second life to the launcher's subsystems while also providing a powerful data acquisition system during the nominal mission. Furthermore, we demonstrate the design, implementation and qualification of a high-performance payload bus system based on commercial-off-the-shelf (COTS) components inside a protective container that offers a well-defined and safe interface shielding the launcher from malfunctions of a payload and protecting the payload(s) from the harsh environment on board the launcher. The developed system is capable of serving the outlined use cases.

### *1.1 Related Work*

The use of COTS-based systems and subsystems in space has been studied extensively. Key arguments for the use of COTS components are reduced weight and better availability as well as increased performance and energy efficiency. In order to guarantee mission success, however, they need to be tested extensively or require additional effort to make them more reliable, thus sacrificing parts of their performance advantage [1,2,3].

To protect components and entire payloads from the harsh vibrations and pyrotechnic shocks during lift-off, dampening systems such as SoftRide® have been proposed and successfully applied [4,5]. Our foam-based protective container does, however, not only protect the enclosed system from vibration and shock,

but also from rapid changes in temperature and provides a pressurized environment.

While first stage recovery has successfully been performed multiple times by SpaceX [6] and similar concepts are under investigation [7], even specifically for ARIANE5 [8], recovery and reuse of an orbital upper stage have not been performed commercially since the Space Shuttle. Although concepts for fully reusable launchers are under investigation [9], it is unlikely that such a system becomes operational in the near future, thus wasting the fully functional upper stage subsystems for the time being.

Data compression on science and payload data such as images and other multi-dimensional data is crucial to effectively handle the big amounts of data these instruments produce. A number of different compression schemes exist, tailored for the specific characteristics of the underlying data [10].

Compression on housekeeping data, however, is rarely applied. With increasing numbers of sensors as well as increasing resolution in time and value domain, the amount of acquired data justifies the use of compression schemes. Compression has successfully been applied to the protocol part of telemetry packets of the Rosetta mission [11]. However, to the best of our knowledge, there is no adaptable compression scheme that specifically targets the acquired sensor data.

### *1.2 Structure*

The paper unfolds as follows:

In Section 2, an overview of the targeted mission scenario is given. We describe possible enhancements and extensions to the nominal mission before explaining the extended mission reusing the launcher's subsystems to conduct technology experiments.

Section 3 describes the MaMMoTH-Up system that has been designed, implemented and tested. Starting with the concept of the protective container and interfaces towards the ARIANE5 upper stage, we subsequently depict hard- and software of the COTS-based system. In terms of hardware, we describe the on-board computers and custom-built IP cores for data acquisition. In terms of software, the mission controller as well as the data processing, compression and monitoring chains are characterised in detail. Our contributions of securing the COTS components in terms of software-based self-testing and reliability analysis complete the section.

Section 4 discusses the results obtained during design, development and testing.

Section 5 concludes the paper.

## **2. Mission Scenario**

In this section, we describe the twofold potential of the use of a powerful COTS component-based payload system on board an upper stage. The increasing

computational power can be used to contribute to the nominal mission of a launcher by providing data acquisition and imaging capabilities or safely introduce new key technologies such as wireless communication (cf. Section 2.1). On the other hand, such a system could also add a completely new use case to an upper stage by reusing its subsystems to conduct science and technology experiments on board the upper stage after its nominal mission has been completed (cf. Section 2.2).

### *2.1 Benefit for the Nominal Mission*

Today, the environmental conditions and mechanical stress in terms of temperature, shock and vibration that the ARIANE5 is exposed to during lift-off are only measured during predefined time spans and with limited accuracy. Precise determination of the spacecraft's performance, however, is crucial in order to introduce structural improvements or new materials. Due to limited bandwidth towards ground and on-board processing capabilities, increasing the amount, cadence and precision of the existing data acquisition system is very expensive because it involves extensive development efforts and requalification of the launch vehicle.

Instead, we propose a modular, minimally invasive COTS-based data acquisition system making use of unoccupied space on ARIANE5's avionics bay. Using an RS422 extension to the existing central telemetry unit, the envisaged system's output can be integrated in the existing downlink. By keeping the electrical interfaces coherent with existing data acquisition units, we ensure that the new system is easily integrated with existing electronics and can be controlled from the central telemetry unit with minor changes to current control schemes.

With the computational power and flexibility of a COTS-based system at hand, data processing, selection and compression can be applied to acquired sensor data to optimize the information throughput of the given downlink. A rating of the sensor output from relevant to irrelevant determined by engineers during mission definition and by the system depending on sensor output, it is ensured that data selected for downlink is meaningful for later analysis.

Modular and affordable hardware and software acquisition schemes enable design engineers to flexibly place additional high resolution sensors for each individual mission (i.e. launch). Offering widely-used interfaces such as SpaceWire, RS422 and CAN, our proposed system can furthermore introduce new technologies such as smart or wireless sensors to the launcher without the need to adapt these to standard ARIANE5 interfaces.

Due to its modular structure that allows combining multiple interconnected processing, storage and acquisition elements, the system may be extended by

imaging capabilities for image and video footage during the launch. Several possibilities to extend the system functionality in this direction are currently under consideration.

With its data acquisition and processing capabilities as well as future possibilities to generate imagery during the launch, the proposed system can make a significant contribution to the nominal mission of the launch. A second use case beyond the nominal mission that reuses core parts of the launcher's telemetry system is depicted in the next section.

### *2.2 Extended Mission*

For typical scientific satellites, the number of subsystems that are required to enable experiments to be conducted in space is numerous. A standard satellite consists of a communication subsystem for radio transmission and reception, a power subsystem for power generation and distribution, an AOCS for orbital manoeuvring and attitude control, a rigid structure for holding the components and an optional thermal control system in case a specific temperature range is crucial. Altogether, for a typical scientific satellite, about two kilograms of satellite bus per kilogram of payload mass have to be launched. However, these subsystems usually offer no benefit to the customer and do not contribute to the mission's scientific output.

For a typical upper stage, on the other hand, all these subsystems are imperative as well. However, after the launcher has fulfilled its nominal mission of delivering its payload(s) to orbit, the upper stage is passivated and is deorbited either actively or passively in the course of several years. Essentially, this means that fully functional components and subsystems whose launch has already been paid for are deliberately becoming space debris and are bound to burn up in the atmosphere.

Instead of dumping these components, we propose to inhale a second life to the upper stage's subsystems and use them to conduct experiments right on the unutilized upper stage. By using unoccupied space on the upper stage, lightweight technology or scientific experiments can rely on the upper stage's infrastructure in terms of power supply, communications and structure. Not having to specifically include these components in the mission does not only save their weight during the launch but also offers massive cost savings during design, development and testing as these subsystems are already qualified and standardized. This puts the ability to gain flight heritage in reach for academic institutions and SMEs.

Additionally, the GTO as targeted by many commercial launches offers interesting characteristics in the sense that it is subject to a variety of different radiation levels and changes in the earth's magnetic and gravity field including the Van Allen radiation belts, for instance (cf. Fig. 1). This provides a wide range of

interesting phenomena to be studied in both scientific and technology experiments.

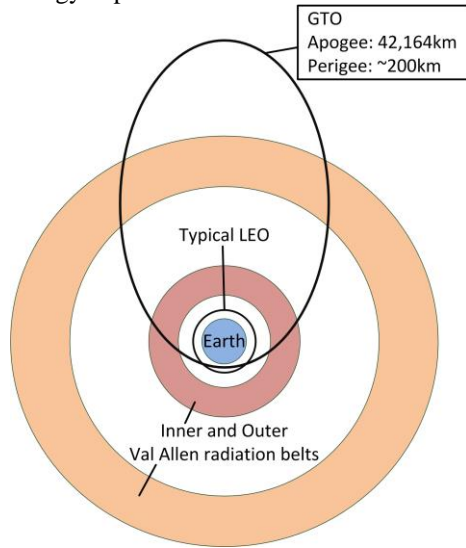

Fig. 1: Geostationary Transfer Orbit (GTO) and Van Allen radiation belts

To cause minimal integration effort on the launcher, to be minimally invasive concerning the nominal mission and to be able to add the use case described above to existing launchers with little effort, a well-defined interface for possible experiments is desirable. To overcome this need, a powerful payload bus, that also offers significant contributions during the nominal mission as described in section 2.1, was developed in the Horizon 2020 project MaMMoTH-Up. The resulting demonstrator and its key technologies that were designed, implemented and qualified during the project are described in the following section.

### 3. The MaMMoTH-Up System

#### 3.1 System Overview

The MaMMoTH-Up mission statement is defined as follows:

*“MaMMoTH-Up represents a permanent adaptable experiment opportunity located on the ARIANE5 (A5) Vehicle Equipment Bay.*

*Protected by a dedicated container design it shall make extensive use of COTS hardware and advanced software to achieve its ambitious data collection, processing and compression tasks. This COTS approach is secured by tailored dependability technics to ensure a reliable operation in the demanding space environment.*

*To downlink the gathered, processed and compressed data MaMMoTH will make use of the A5 telemetry subsystem acting as a peripheral data acquisition unit once a standard A5 mission is completed. A future application also on ARIANE6 is envisaged.” [12]*

To fulfil this mission, a COTS-based system based on three processing elements, a power supply unit and two data acquisition boards in a protective container (cf. Section 3.2) has been developed. These are interconnected using SpaceWire. One of the processing elements (named TCM-S, cf. Section 3.3) represents the mission controller. It interacts with the launcher (cf. Section 3.2.2) and features a mass memory for intermediately storing telemetry data. The remaining processing elements (named OBC-S) each have an associated acquisition board (AQB) attached that connects to a set of vibration, shock, temperature and pressure sensors. These serve as a reference mission to increase the data acquisition capabilities of the launcher. For later mission, they may be exchanged for an imaging system or a technology experiment.

The computationally challenging task of data processing is split between the processing elements for an optimal workload. The OBC-S boards perform preliminary transformations, whereas the TCM-S is responsible for data analysis and compression (cf. Section 3.4).

To secure the COTS approach, structural software-based self-tests are executed at critical moments before and during the mission to detect permanent faults. A concept of graceful degradation ensures that the system retains some useful functionality even in the presence of failing subcomponents (cf. Section 3.5). The overall MaMMoTH-Up system is depicted in Figure 2.

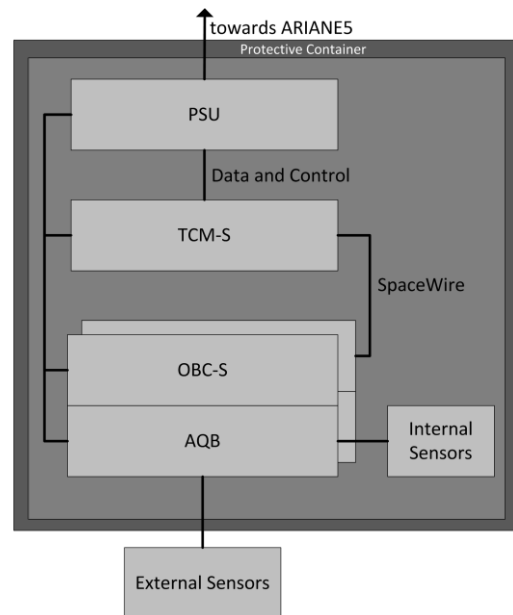

Fig. 2: MaMMoTH-Up System Overview

#### 3.2 Protective Container

In order to operate high performant but relatively sensitive COTS-based systems under the demanding environmental conditions on the launch vehicle, various

studies were conducted in the past to develop different shelter technologies [13]. For MaMMoTH-Up, special emphasis was put on the protection against vibration and of the COTS-based system. A dedicated hermetic protective container design has been implemented [14] (cf. Figure 3). Being hermetic, it enables to incorporate components and materials that degrade or fail in low pressure or vacuum conditions. Furthermore materials with delicate out-gassing or off-gassing properties can be used inside the MaMMoTH-Up container, since the contamination of the launcher or even its payload is prevented.

### 3.2.1 Structure

The protective container is a combination of an outer container and a smaller internal carrier rack. The carrier rack embedded inside the external container using a set of foam pads which absorb external mechanical loads. Due to the fact that foam has non-linear mechanical properties, numerous studies and mechanical characterization tests have been done to select good foam configurations.

The successful final vibration qualification test with the full system proved the container concept and design.

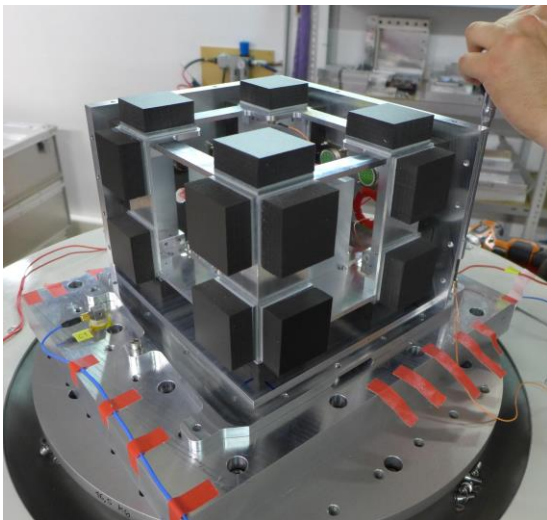

Fig. 3: MaMMoTH-Up Container model (partly disassembled) during vibration tests

To connect the COTS-based system (here DHS) inside the container, a dedicated electrical harness has been designed and implemented. Since there is a significant relative mechanical displacement of the internal rack (caused by the foam elasticity) in relation to the outer container in case of vibrations, the harness design and connector location had to respect both the need for sufficient movement and for tight fixation close to the interfaces.

The outer container provides the mechanical and electrical interface towards the launch vehicle.

### 3.2.2 Interfaces to the ARIANE5

The MaMMoTH-Up Container has been designed to be placed inside the ARIANE5 avionics bay. A location has been selected, that was initially occupied during the first flights of the ARIANE5 ECA launcher and is now vacant. MaMMoTH-Up has been designed to operate as independently from the launcher as possible; nevertheless, a few interfaces are implemented (cf. Figure 4):

- Telemetry interface to the launcher's main telemetry unit to feed the acquired and processed data into the telemetry downlink
- Control and synchronization interface to the launchers sequential controller unit
- Power interface
- Ground test interface to EGSE to enable the configuration and testing of MaMMoTH-Up during the integration and launch preparation phase
- The mechanical bolted interface to fix the MaMMoTH-Up container on the launcher avionics platform

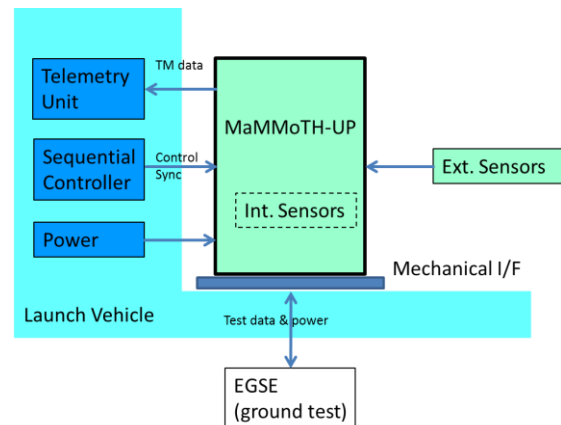

Fig. 4: MaMMoTH-Up launcher interfaces

### 3.3 Hardware

The DHS subsystem (cf. Figures 5,6) is an integration of modular products providing one Power Supply Unit (PSU), one Sirius TCM unit, and a pair of Sirius OBC units combined with an acquisitions board (AQB) on top (cf. Figure 7). The AQB provides sensor interfaces for both the external ARIANE5 sensors and the internal container sensors. All sensors are measured with high performance using FPGA logics. The measured data is forwarded to the TCM mass memory for storage before it is downloaded to ground via radio. The actual MaMMoTH-Up DHS Qualification Model can be seen in Figure 6. With a weight of only 875g, its dimensions are 130 \* 126 \* 90mm (L\*D\*H).



Fig. 5: The DHS mechanical structure



Fig. 6: The DHS Qualification Model

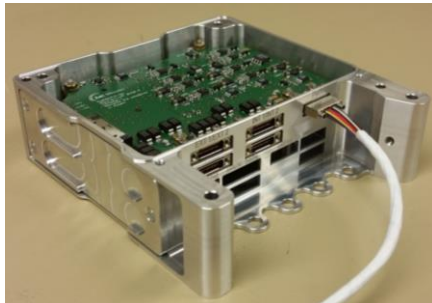

Fig. 7: Mechanical casing of OBC-S and AQB

Externally, the DHS features three closed current loops (CMD-3) to be controlled by the launcher's sequential electronics (ES). Eight discrete telemetry status bits (TM-8) provide a direct equipment status for the launcher. Acquired data is sent to the launcher by the unidirectional RS422 interface. Power supply is provided either by the EGSE or by a dedicated battery. The voltage range of the DHS is also designed to be used directly with the launcher's power system. Further interfaces for the EGSE include a bidirectional SpaceWire interface that allows commanding the system and getting deeper insight into the inner state, reset inputs for individual boards and a PPS signal for time synchronization.

Additionally, a total of 38 analogue sensors can be attached, each with a maximum sampling frequency of 10 kHz. For the reference mission, 22 of these are used

inside the protective container and 16 are forwarded to the outside of the protective container (cf. Table 1).

Tab. 1: Internal and external sensor channels

Sensor type	# Internal	# External
Pressure	1	3
Delta Pressure	-	1
Temperature	5	3
Vibration	3	3
Shock	3	3
Strain Gauge	4	-
Acceleration	-	3
Spare	6	-
<b>Total</b>	<b>22</b>	<b>16</b>

To increase future connectivity, two spare RS422 and a CAN interface have been included. These can be used as wireless access points or payload interfaces. For demonstration purposes, an exemplary CAN pressure sensor is operated by the system. The interfaces of the MaMMoTH-Up DHS are depicted in Figure 8.

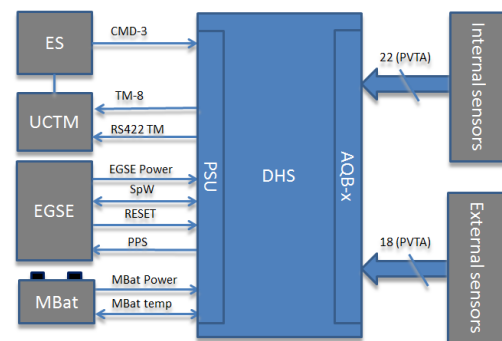

Fig. 8: DHS external interfaces

### 3.3.1 On-board Computers

The core of the DHS consists of three processing elements, one experiment controller (TCM-S) including a mass memory for data storage and two on-board computers (OBC-S) for data acquisition.

The TCM-S and OBC-S products (see Figures 9, 10) are part of the Sirius product family that follows the CubeSat form factor standard. The following interfaces and features are provided by the COTS products:

- JTAG interface (1)
- DEBUG interface (1)
- Power connection with integrated PPS(1), PULSE (2), PSUCTRL RS485 (1) signals
- SpaceWire ports (2)
- CCSDS S-band radio port (1, only TCM-S)
- CCSDS X-band radio port (1, only TCM-S)
- UMBI interface (1, only TCM-S)
- Pulse outputs (12, only TCM-S)
- RS422/485 ports (3, OBC-S: 6)
- GPIO ports (12, OBC-S: 16)

- 16GB mass memory (only TCM-S)
- SCET, PPS time sync
- Status and error detection
- HK sensors



Fig. 9: The Sirius TCM COTS product



Fig. 10: The Sirius OBC COTS product

### 3.3.2 Custom boards and IP Cores

The Power Supply Unit (PSU) is a customization for the project that shares the CubeSat form factor of the COTS units.

The PSU is constructed as a two compartment unit (cf. Figure 11) using one compartment for the DCDC converter, input protection and 7 V latching current limiters (LCLs). The second compartment houses the controller, interface adaptation circuits and acquisition board LCLs.

There are two interfaces for commanding the PSU: the wired command interface (CMD-3) and the PSUCTRL RS-485 interface. The wired command interface allows the PSU, and MaMMoTH-Up, to be switched on and off through a pulse duration coded input. The PSUCTRL interface allows the TCM to control the state of all secondary distribution switches and LCLs and to fetch housekeeping parameters.

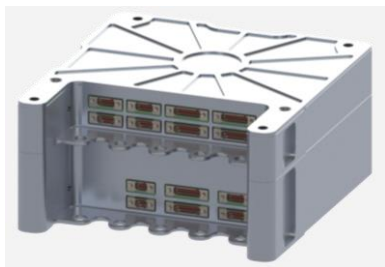

Fig. 11: Illustration of the Power Supply Unit (PSU)

The Acquisition board (AQB) is a customization for the project that shares the CubeSat form factor of the COTS units. The AQB is mounted above the OBC using the board-to-board Vertical I/O interface. A custom mechanical frame has been added for enclosing both the OBC and AQB units into one product (cf. Figure 7).

The Vertical I/O is an extended interface placed on the OBC board that enables integration with customized boards.

A FPGA placed on OBC has access to the Vertical I/O interface that enables custom RTLs to control and request data from measurements executed by the AQB board.

The customized RTL logic (Intellectual Property (IP) blocks) contains both integration of 8 channel analogue-to-digital 12bit converters (ADC) and a CAN controller (see Figure 12).

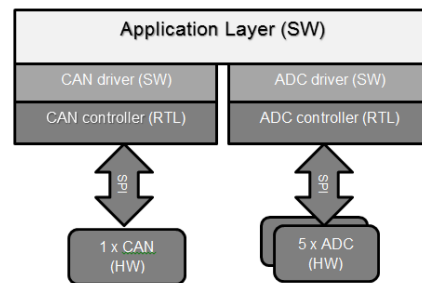

Fig. 12: The main IP block interface

The ADC controller is triggered by the on-board software through the ADC driver. The software sets the desired sampling rate and block size (i.e. number of data points) and issues a read command to the IP block. The IP block acquires the requested number of samples from the ADC and initiates a DMA transfer in order not to stress the CPU with evitable copy instructions. Once the DMA transfer is complete, the IP block issues an interrupt to the CPU which can then access the sensor data for further processing.

### 3.4 Software

The software developed in MaMMoTH-Up shall be as independent from the underlying hardware and Real-Time Operating System (RTOS) as possible to ease the reuse in later projects. This is achieved by introducing the middleware OUTPOST (Open modular softWare PlatfOrm for Spacecraft), formerly known as libCOBC, developed at DLR [15].

The overall layered architecture is depicted in Figure 13. On top of the hardware, the operating system RTEMS [16] and the board support package (BSP) providing software access to board-specific bare metal features are located.



Furthermore, drivers are implemented to provide a higher level access to peripherals and devices next to the processor. OUTPOST is located on top of the operating system, the BSP and, partly, the drivers and is acting as a middleware for the application.

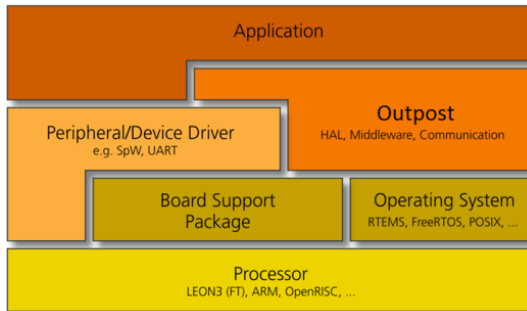

Fig. 13: Layered architecture [15]

The OUTPOST-library provides an extensible, robust and reusable software platform. Its implementation is based on the CCSDS/ECSS recommendations. The core elements of this platform are composed of a hardware abstraction layer, an operating system layer, a middleware layer, and essential services like a CCSDS/PUS software stack and a timing module.

### 3.4.1 Logging Framework

Only with a detailed knowledge about the internal state of the system, reasons of current and past failures can be revealed, errors can be deduced and avoided in future and, finally, the mission goal can be fulfilled successfully. Nowadays, a variety of methods of gathering the internal information of the spacecraft exist [17]:

- Monitors using the JTAG target interface
- Logic Analyzers and Oscilloscopes
- Software Monitors
- printf-Debugging [18]
- Telemetry Messages

The applicability of these methods strongly depends on the development phase, the source the information is coming from, and the intended user group which can range from software developers over spacecraft engineers to mission control centres. Until now, it is necessary to implement at least most of these methods in order to grant insight into the system during all development phases and to all actors. This increases the number of system interfaces and, therefore, significantly increases development efforts.

However, one of the main contributions of [19] is an approach for a so called unified monitoring framework handling as much of the spacecraft status information as possible in one common system which shall be used by all involved actors throughout all development phases. While already planned for application in DLR's

Eu:CROPIS mission (launch planned for 2018) [15], this unified monitoring framework is also applied in MaMMoTH-Up. Furthermore, the framework is extended to allow self-configuration and self-testing during the mission. This will be achieved by providing a level-based interface towards the telemetry system for each application. This allows assigning a level of visibility to each individual application and filtering logging or debugging messages according to their importance with respect to the current system health status and mission state.

Furthermore, in order to provide the comfort of string-based printf-debugging messages while still keeping bandwidth requirements to a minimum, an automatic compile-time replacement was developed.

### 3.4.2 Data Acquisition

Emerging from the described hardware architecture, the data acquisition chain is distributed to all processing elements. The AQB's perform signal adaptations for the various kinds of sensors (cf. Table 1) before the signals can be sampled by the ADCs. The ADC controller (RTL) on the OBC-S board retrieves the digital values in block-wise fashion per sensor (i.e. ADC channel) and notifies the software once a block is complete. The on-board software then takes care of any further processing.

### 3.4.3 Data Processing

In order to optimize the information throughput of the given downlink, the sensor data has to be compressed. Since lossless compression does not offer the necessary compression rates, lossy compression schemes as well as intelligent data selection are applied. Since the characteristics of sensor data with soft gradients (temperature, pressure) or reappearing patterns (vibration) resembles rows or columns of image data, we propose to apply similar compression schemes as for two-dimensional data like JPEG2000 [20] that – in contrast to JPEG [21] – allows lossless compression which is crucial for very important blocks of sensor data [22,23].

Compression schemes like JPEG2000 are based on mathematical transformations that are applied to the underlying data followed by quantization of the resulting coefficients and efficient encoding. In the MaMMoTH-Up system, the computational load of this process is shared between the processing elements. The initial transformation is applied by the OBC-S before sending the resulting coefficients to the TCM-S, that analyses the data, encodes, compresses and sends it to ground. This process is depicted in Figure 14.

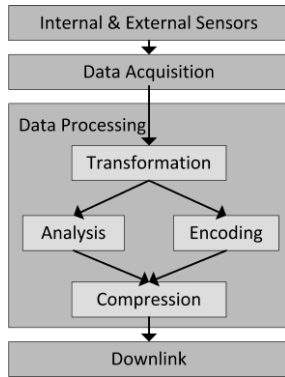

Fig. 14: Data Acquisition Chain in MaMMoTH-Up

JPEG2000 first applies a Discrete Wavelet Transform (DWT). Wavelet refers to the appearance of the underlying high and low pass filter functions which resemble a wave (cf. Figure 15). We have chosen to use the Cohen-Daubechies-Feauveau (CDF) 5/3 as applied by the lossless JPEG2000 variant because it can be implemented with only additions and shift operations and yields very good results. The wavelet is used to filter the underlying data in multiple passes, disassembling it to coefficients on multiple time- and frequency scales. This results in a shift of the information contents of the entire block to the upper coefficients while leaving most of the remaining coefficients close to zero. This means that the magnitude of a coefficient directly relates to its contribution to the entire block. Hence, coefficients close to zero can safely be omitted during transmission without introducing too much error to the reconstructed signal. By omitting more and more coefficients, a user-defined trade-off between Compression Ratio (CR) and introduced error (i.e. Mean Square Error (MSE)) can be achieved.

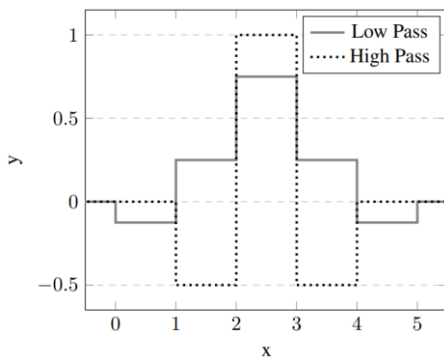

Fig. 15: Cohen-Daubechies-Feauveau 5/3 (CDF-5/3) Wavelet [23]

To further increase the compression ratio, we propose an adaption of the No List Set Partitioning in Hierarchical Trees (NLS) coding scheme by Wheeler and Pearlman [24], that accounts for the one-dimensional nature of time-series data. The scheme

builds on Embedded Zerotree Wavelet (EZW) coding depicted in Figure 16 [23,25]. By pivoting bitplanes and transmitting most significant bits first, it is ensured that the information that is most important for reconstruction is transmitted first. At the same time, this encoding creates a so-called embedded bitstream that, when cut at any point, still represents a valid sequence for reconstructing the whole signal. This makes the actual data compression very easy, since it is simply performed by cutting the stream at the desired point.

sign	s	s	s	s	s	s	s	s
msb 5	1	1	0	0	0	0	0	0
4	→		1	0	0	0	0	0
3	→		→	1	0	0	0	0
2	→			→	1	1	1	0
1	→						→	1
lsb 0	→							→

Fig. 16: Binary representation of coefficients in the Embedded Zerotree Wavelet (EZW) coding [25]

The performance of this scheme is briefly displayed in Figure 17. A more comprehensive study including its application to real-world sensor data from ARIANE5 and DLR's AISat can be found in [23]. The scheme is clearly outperforming previous implementations based on the Discrete Cosine Transform (DCT) [22]. Note that the application of the simple CDF-5/3 wavelet even outperforms more complicated wavelets like the CDF-9/7 that requires almost double the computational effort.

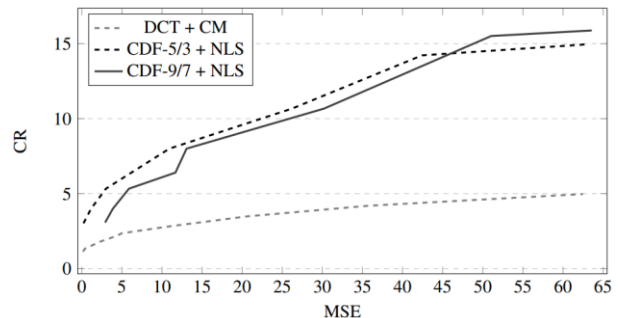

Fig. 17: Compression Ratio and Mean Square Error for the AISat temperature sensor

For data analysis, mainly a subclass of recurrent neural networks, so called long short term memory cells (LSTM cells), is investigated. From time-series sensor data collected in the past, these cells can learn to predict recurring patterns in the data. By comparing these predictions to actual data, the system can estimate a so-called anomaly score which indicates whether the data can be considered nominal or abnormal. Significant challenges for this approach are the limited memory and processing power constraints of an embedded system

and the absence of meaningful training data due to the flexible placement of sensors. Hence, online training of the network is mandatory as well limiting the number of input variables. To effectively handle this issue, specific characteristics of the wavelet coefficients resulting from the aforementioned wavelet compression scheme are used instead of the direct sensor values. This allows to apply the data analysis to large blocks of sensor data while still keeping the number of input variables low.

Due to the limited downlink budget during flight, the system prioritizes those blocks of sensor data that have higher anomaly scores. Furthermore, the compression ratio is adjusted depending on the anomaly scores: The more anomalous a block of sensor data the more bytes of the downlink budget are allocated to allow for a more exact restoration of the data on ground. This is possible thanks to the aforementioned embedded bitstream produced by the NLS encoding scheme.

First results in this field look promising and will be published in the near future.

### 3.5 Securing the COTS approach

In the past years, the adoption of COTS components in space applications has been widely explored. The shift from space qualified to COTS components is motivated by several reasons, among which the major one is the availability of a much larger set of COTS components, including products with more attracting characteristics (e.g., higher performance). On the other side, the usage of COTS components generally requires a careful evaluation of the changes they introduce in the procurement, design and test steps (among the others) and of the related impact on their cost. Hence, the consequences stemming from the adoption of COTS components and whether their adoption is really convenient must be evaluated case by case. In particular, it is crucial to perform a careful analysis of how the dependability figures of a system including COTS components can be evaluated and which actions are possibly required to match the target dependability figures. In the case of the MaMMoTH-Up system, the adoption of COTS components (including memories and FPGAs) allowed to achieve significant benefits in terms of computing and storing performance, and hence allowed the system to support much more powerful features with respect to its predecessor. On the other side, the usage of these components required the implementation of some actions to successfully face temporary and permanent faults which may affect them, as well the definition of a suitable procedure for the estimation of the dependability figures that can be achieved by the system.

In the following, we will first summarize the procedure to perform the reliability analysis, and then focus on the self-test solutions adopted in the MaMMoTH-Up system.

#### 3.5.1 Reliability Analysis

For the sake of the reliability analysis, the MaMMoTH-Up reference mission profile can be split in two broad parts. The first part refers to the manufacturing, assembly and transport to the launch site, while the second part refers to the launch and operational life of the system during the ground to orbit voyage.

As far as the first part of the mission profile is concerned, the system could be affected by permanent faults originated during the manufacturing, assembly and transport processes. Conversely, during the second part of the mission profile alongside the possible occurrence of permanent faults due to the stresses originated during the launch, transient/permanent faults could be originated due to the radioactive environment in which the system is operating. For this purpose, we performed two investigations.

We analysed the reliability of the MaMMoTH-Up system while considering permanent faults; firstly, we evaluated the effects of permanent faults on the electronic components, connectors, and boards composing the MaMMoTH-Up system, obtaining the respective failure rate by using the FIDES reliability calculation model [26]; secondly, we performed the Failure Mode, Effects, and Criticality Analysis (FMECA), taking into consideration for each component the relevant failure modes, then for each failure mode we analysed the effect on the board where the faulty component is mounted, and finally we evaluated how the fault reaching the board outputs could propagate through the system, eventually reaching the MaMMoTH-Up system outputs thus manifesting itself as failure. In this analysis, we considered the contribution of the different fault management techniques that MaMMoTH-Up system includes as well as the different test activities performed during the mission. At the end of this analysis we were able to compute the expected failure rate for the MaMMoTH-Up system and its unreliability with respect to permanent faults.

We then analysed the impact of the radioactive environment to the electronic components in the MaMMoTH-Up system: relevant radiation effects have been considered and their effects on the system were evaluated, while considering the mitigation techniques the system embeds. At the end of this analysis we were able to compute the radiation effects on the MaMMoTH-Up system as a whole.

Finally, we performed a fault injection campaign on the most relevant part of the MaMMoTH-Up system to validate the main error mitigation techniques it implements. In this analysis we performed fault injection experiments on the processor core implemented in most of the MaMMoTH-Up boards to assess the effects of single event upsets (SEEs).

The key finding of the reliability analysis are that as far as SEEs are concerned, the mitigation techniques that MaMMoTH-Up electronic adopts (e.g., redundancy of memory elements, EDAC, anti-latch-up) are effective to protect the system against the radioactive environment. As far as permanent faults are considered, particular care must be placed in the test procedures for the most complex device used in the system that is the COTS FPGA device that equips most of the MaMMoTH-Up boards.

### 3.5.2 Software-based Self-Test

In order to achieve the target reliability figures, in particular taking into account the impact of possible permanent faults, it is crucial to test the different parts of the MaMMoTH-Up system in different times during its life time, with special emphasis on the FPGA device. The latest test steps must be performed when the system is already installed in its final position in the launcher and during the flight. In this scenario, the test must be performed without any significant support from the outside apart from triggering the test and monitoring its results. Hence, the only viable solution is to rely on a self-test, based on forcing each unit of the system to activate a self-test. This self-test should guarantee a sufficient Fault Coverage. Given the complexity of some of the used COTS components (e.g., the FPGA devices), adopting a *functional* approach (aimed at checking whether the system is able to correctly perform the functions it is intended for) is ineffective. A detailed analysis we performed [27] showed that the Fault Coverage guaranteed by a functional approach with respect to the permanent faults which may possibly affect the FPGA device is far too low with respect to what is required to achieve the target reliability figures. Hence, we moved to a *structural* approach, which adopts a fault model related to the physical structure of the circuit implemented within the FPGA, and developed a self-test able to achieve a sufficient Fault Coverage with respect to the fault list resulting from the adoption of such a fault model. In our case, the adopted fault model is the common stuck-at-1/stuck-at-0 referring to the gate-level netlist of the circuit mapped on the FPGA, following what is done in other domains, such as the automotive one [28].

Since the circuit implemented within each FPGA device includes a CPU, the self-test we developed following this approach is based on the Software-based Self-test paradigm (SBST) [29]. In this case, when the test is triggered, the CPU is forced to execute a properly written piece of code (corresponding to a set of self-test procedures), which is able to fully exercise the circuit and to make the effects of possible faults affecting it visible in terms of produced results.

In order to make the whole approach viable with respect to the MaMMoTH-Up system constraints, we

also developed some techniques able to minimize the time required by the self-test procedures to run [27,30].

Moreover, in order to properly perform the reliability analysis and correctly compute the achieved Fault Coverage, we had to identify those faults, which for some reason can be proved not be able to produce any failure in any operating conditions (Safe Faults). Some new techniques to automate this step and to make it less error prone have been developed [31].

Resorting to fault simulation tools, we have been able to compute the fault coverage achieved by the developed self-test procedures, which is higher than the minimum values required to achieve the target reliability figures for the whole system. The code of these procedures has finally been integrated into the application and system code running on the different boards composing the system.

### 3.5.3 Graceful degradation

Since the MaMMoTH-Up DHS does not provide any structural redundancy on unit- or subsystem-level, an approach of graceful degradation in the presence of failures is applied. This ensures that the system fully exploits its resources – mainly in terms of bandwidth to ground – even with single subsystems failing due to uncorrectable failures. This is achieved by reallocating resources from failing components to fully functional units.

As mentioned above, additional to the error detection capabilities of the processors' memories that are woven into the RTL code, MaMMoTH-Up uses structural SBST (cf. [30,31,32]) to check its computing units for permanent faults.

On start-up, these test procedures are invoked automatically by each board. The result of any single procedure is reported to the TCM-S and to ground via the logging framework. In case a generated signature deviates from its expected value, the test is repeated up to three times to exclude temporary upsets as a possible cause. Should the deviation persist, the software system initiates a soft reset, meaning that the software is reloaded, volatile memory is cleared, but all IP cores (especially the SCET timer) remain in their current state. Up to this point, the activation mechanism for the TCM-S and the OBC-S boards is identical. In case a failure persists beyond this point, however, counter measures differ due to the inability of the TCM-S to perform a power cycle on itself. This is why the TCM-S, being a single point of failure, tries to continue to work nominally despite persisting failures in a best-effort fashion. The OBC-S on the other hand, should it detect an uncorrectable error after a soft reboot, reports the issue to the TCM-S which initiates a power cycle of the corresponding board by switching its LCL via the PSU. In the event not even a power cycle could correct the error, the TCM-S deactivates the respective board

on a second error report to reassign its transfer budget to the remaining OBC-S.

After the system has booted, the TCM-S takes over control of the test procedures. During the mission (i.e. the launch), the test procedures are executed in regular intervals depending on the computational load of the operational mode to check that the system remains fully functional. In case one of the boards detects a failure, the recovery procedure is similar to the boot process. First, the corresponding test is repeated by the affected board. On persistence, a soft reboot is initiated, following by a report to the TCM-S that may decide to run a power cycle for the board or deactivate it completely on repeatedly failing tests.

All events and results within this procedure are reported to ground via the logging framework.

#### 4. Results

To demonstrate the readiness of the described technologies as well as the integrated system, we successfully performed a number of environmental qualification campaigns including rapid depressurization, thermal vacuum testing, vibration testing and electromagnetic compatibility (EMC) testing according to the rather demanding ARIANE5 specification. Similar to an actual launch, the MaMMoTH-Up system was active during these qualification tests. We connected a selection of live sensors to successfully verify the data acquisition chain compared to the reference sensors of the corresponding test facilities.

Together with the reliability analysis, that confirms the necessary overall reliability given a good set of self-tests to reach sufficient FC, this clearly shows that the MaMMoTH-Up system is on an excellent way to reach flight-readiness.

In order to fully demonstrate flight-readiness, however, thermal and shock qualification campaigns need to be executed.

Also, to further optimize the information throughput of the given downlink, investigations of data selection and analysis algorithms have to be completed as well as implemented.

#### 5. Conclusion

In this paper, we have presented a new mission concept that reuses subsystems of an upper stage for conducting further experiments after the nominal launch. At the same time, we have proposed a system that serves this use case and offers additional benefits to the launch provider in the form of modular data acquisition. With the computational power of the COTS system that executes an adaptable data acquisition scheme, it allows to monitor the upper stage precisely and flexibly, tailored to the specific mission. Future improvements to gather image and video data are within close reach. By

using SBST and a concept of graceful degradation, the COTS approach is secured in terms of overall system reliability. The system is enclosed in a protective container, thus safely encapsulating the launcher as well as the payload and its bus from one another. As it is strictly designed to be minimally invasive to the launcher's electronics, the system can be integrated in existing systems with manageable effort.

In the technologies and modular system concept proposed in this paper, we see great potential to decrease the cost for technology experiments, effectively monitor existing launchers and even provide a flexible door opener for emerging launcher technologies.

#### Acknowledgements

This paper has received funding from the European Union's Horizon 2020 research and innovation programme under grant agreement No 637616.

#### References

- [1] S. Esposito, C. Albanese, M. Alderighi, F. Casini, L. Giganti, M.L. Esposti, C. Monteleone, M. Violante. COTS-Based High-Performance Computing for Space Applications. *IEEE Transactions on Nuclear Science*. Vol. 62, No. 6, pp. 2687-2694, 2015
- [2] H. Madeira, R. R. Some, F. Moreira, D. Costa, D. Rennels. Experimental evaluation of a COTS system for space applications. *International Conference on Dependable Systems and Networks*, Washington DC, USA, 2002
- [3] M. Pignol. COTS-based applications in space avionics. *Design, Automation & Test in Europe Conference & Exhibition (DATE)*, Dresden, Germany, 2010
- [4] C. D. Johnson, P. S. Wilke, S. C. Pendleton. Softride vibration and shock isolation systems that protect spacecraft from launch dynamic environments. *38th Aerospace Mechanisms Symposium*, Langley Research Center, 2006.
- [5] P. Wilke, C. Johnson, P. Grosserode and D. Sciulli. Whole-spacecraft vibration isolation for broadband attenuation. *IEEE Aerospace Conference*, Big Sky, MT, USA, Mar. 2000
- [6] M. Wall. Wow! SpaceX Lands Orbital Rocket Successfully in Historic First <https://www.space.com/31420-spacex-rocket-landing-success.html>, space.com, retrieved August 28<sup>th</sup> 2018
- [7] E. Dumont, T. Ecker, C. Chavagnac, L. Witte, J. Windelberg, J. Klevanski, S. Giagkozuglou. CALLISTO - Reusable VTVL launcher first stage demonstrator. *Space Propulsion Conference*, Sevilla, Spain, May 2018
- [8] E. Dumont, S. Stappert, E. Tobias, J. Wilken, S. Karl, S. Krummen, M. Sippel. Evaluation of Future

- Ariane Reusable VTOL Booster stages. International Astronautical Congress (IAC), Adelaide, Australia, Sep. 2017
- [9] M. Sippel, O. Trivailo, L. Bussler, S. Lipp, C. Valluchi. Evolution of the SpaceLiner towards a Reusable TSTO-Launcher. International Astronautical Congress (IAC), Guadalajara, Mexico, Sep. 2016
- [10] P.-S. Yeh, P. Armbruster, A. Kiely, B. Masschelein, G. Moury, C. Schaefer, C. Thiebaut. The new CCSDS image compression recommendation, IEEE Aerospace Conference, Big Sky, USA, 2005
- [11] J. Martínez-Heras, D. Evans, R. Timm. Housekeeping Telemetry Compression: When, How and Why Bother? International Conference on Advances in Satellite and Space Communications, Colmar, France, 2009
- [12] <https://www.mammoth-up.eu>
- [13] R. Knoche, M. Winter, F. Myer. PREPARE - The National Programme to Enhance Upper Stage Performance and Reliability for Future Expendable Launchers - Overview and Status. European Conference for Aeronautics and Space Sciences (EUCASS), Krakow, Poland, 2015.
- [14] W. Oehler, J. Sebald, A. Staiger. Behälter für elektronische Baugruppen. Patent DE10 2011 117 133.
- [15] F. Dannemann, F. Greif. Software Platform of the DLR Compact Satellite Series. Proceedings of 4S Symposium, Malta, May 2014.
- [16] Real-Time Executive for Multiprocessor Systems (RTEMS) <https://www.rtems.org/>
- [17] F. Dannemann, S. Montenegro. Embedded Logging Framework For Spacecraft. Data Systems in Aerospace (DASIA), Porto, Portugal, May 2013
- [18] J. Dassen, I. Sprinkhuizen-Kuyper. Debugging C and C++ Code in a Unix environment. Ch. Debugging techniques. OOPWeb.com, 1999
- [19] F. Dannemann. Towards Unified Monitoring of Spacecraft. 65<sup>th</sup> International Astronautical Congress (IAC), Toronto, Canada, Sep. 2014
- [20] D. S. Taubman and M. W. Marcellin, JPEG 2000: Image Compression Fundamentals, Standards and Practice. Kluwer Academic Publishers. Norwell, USA, 2001.
- [21] G. K. Wallace. The JPEG still picture compression standard. Communications of the ACM, pp. 30–44, 1991.
- [22] J.-G. Meß, R. Schmidt, G. Fey. Adaptive Compression Schemes for Housekeeping Data. IEEE Aerospace Conference (AEROCONF). Big Sky, USA, Mar. 2017.
- [23] J.-G. Meß, R. Schmidt, G. Fey, F. Dannemann. On the Compression of Spacecraft Housekeeping Data using Discrete Cosine Transforms. ESA International Workshop on Tracking, Telemetry and Command Systems for Space Applications (TTC). Noordwijk, Netherlands, Sep. 2016.
- [24] F. W. Wheeler, W. A. Pearlman. SPIHT image compression without lists. IEEE International Conference on Acoustics, Speech, and Signal Processing (ICASSP), Istanbul, Turkey, 2000.
- [25] J. M. Shapiro. Embedded image coding using zerotrees of wavelet coefficients. IEEE Transactions on Signal Processing. Vol. 41, No. 12, pp. 3445–3462, Dec 1993.
- [26] FIDES guide 2009 Edition A September 2010, Reliability Methodology for Electronic Systems
- [27] R. Cantoro, E. Sanchez, M. Sonza Reorda, G. Squillero, E. Valea. On the Optimization of SBST Test Program Compaction. IEEE International Symposium on Defect and Fault Tolerance in VLSI and Nanotechnology Systems (DFT), Oct. 2017.
- [28] <https://www.iso.org/standard/43464.html>
- [29] M. Psarakis et al. Microprocessor Software-Based Self-Testing. IEEE Design & Test of Computers, Vol. 27, No. 3, May-June 2010, pp. 4-19.
- [30] R. Cantoro, E. Cetrulo, E. Sanchez, M. Sonza Reorda, A. Voza. Automated Test Program Reordering for Efficient SBST. Conference on Design of Circuits and Integrated Systems (DCIS), Barcelona, Spain, Nov. 2017
- [31] R. Cantoro, A. Firrincieli, D. Piumatti, M. Restifo, E. Sanchez, M. Sonza Reorda. About Functionally Untestable Fault Identification in Microprocessor Cores for Safety-Critical Applications. 19<sup>th</sup> IEEE Latin American Test Symposium (LATS), São Paulo, Brazil, Mar. 2018.
- [32] S. Carbonara, A. Firrincieli, M. Sonza Reorda, J.-G. Mess. On the test of a COTS-based system for space applications. IEEE International On-Line Testing Symposium (IOLTS), Platja d'Aro, Spain, Jul. 2018.