

Model-based control of torque and nitrogen oxide emissions in a Euro VI 3.0L diesel engine through model-in-the-loop

Original

Model-based control of torque and nitrogen oxide emissions in a Euro VI 3.0L diesel engine through model-in-the-loop / Manelli, Andrea; Finesso, Roberto; D'Ambrosio, Stefano; Ventura, Loris. - ELETTRONICO. - 2191:(2019), p. 020105. (Intervento presentato al convegno 74° Congresso Nazionale ATI tenutosi a Modena nel 2019) [10.1063/1.5138838].

Availability:

This version is available at: 11583/2781152 since: 2020-01-16T13:57:01Z

Publisher:

AIP Publishing

Published

DOI:10.1063/1.5138838

Terms of use:

This article is made available under terms and conditions as specified in the corresponding bibliographic description in the repository

Publisher copyright

AIP postprint/Author's Accepted Manuscript e postprint versione editoriale/Version of Record

(Article begins on next page)

Model-based control of torque and nitrogen oxide emissions in a Euro VI 3.0L diesel engine through model-in-the-loop

Cite as: AIP Conference Proceedings 2191, 020105 (2019); <https://doi.org/10.1063/1.5138838>
Published Online: 17 December 2019

Andrea Manelli, Roberto Finesso, Stefano d'Ambrosio, and Loris Ventura



View Online



Export Citation

ARTICLES YOU MAY BE INTERESTED IN

[Effect of the application of an uncooled high-pressure EGR strategy in low-load diesel PCCI operation](#)

AIP Conference Proceedings 2191, 020055 (2019); <https://doi.org/10.1063/1.5138788>

Lock-in Amplifiers

Zurich Instruments

Watch the Video

Model-Based Control of Torque and Nitrogen Oxide Emissions in a Euro VI 3.0L Diesel Engine through Model-in-the-Loop

Andrea Manelli^{1, a)}, Roberto Finesso¹, Stefano d'Ambrosio¹ and Loris Ventura¹

¹ Politecnico di Torino, Department of Energy, C.so Duca degli Abruzzi 24, 10129, Torino, Italy

^{a)} Corresponding author: andrea.manelli@polito.it

Abstract. A model-based technique for the control of BMEP (Brake Mean Effective Pressure) and NO_x (Nitrogen Oxide) emissions has been developed and then assessed on a FPT F1C Euro VI diesel engine for light-duty applications. The model-based technique requires the adoption of a predictive combustion model to simulate the heat release rate and BMEP, on the basis of the injection pattern, from which NO_x emissions can be calculated. The heat release model is based on the accumulated fuel mass approach which needs as inputs the start of injection of the different pulses and the injected fuel mass quantities. The in-cylinder pressure is then simulated using a single-zone approach. The model-based controller defines the optimal values of SOI_{main} and $q_{f,inj}$ that allow the desired targets of BMEP and NO_x to be reached cycle-by-cycle. The controller has been developed and assessed by means of Model-in-the-Loop (MiL), by coupling a fast running engine model developed in GT-Power environment with the combustion controller developed in Simulink environment. Several load ramps for different engine speeds were simulated in MiL to verify the functionality of the controller. The activity was carried out within a research project in collaboration with FPT Industrial. It was shown that the developed algorithm has a good potential in controlling NO_x emissions and BMEP and features real-time capability. Therefore, it is suitable for the subsequent implementation on the engine through rapid prototyping.

INTRODUCTION

Although the negative political and social attitude against internal combustion diesel engines, they will remain the main propulsion systems for the next ten to twenty years for light-duty and heavy-duty vehicles.

Emerging technologies such as electric vehicles require to develop and install charging stations among the territories due to their reduced mileage; it is important also to reduce the weight of the architecture to install it on heavy-duty vehicles.

Nowadays electric vehicles are diffused in the public transport system, where the urban cycle is known and the charging level of the battery is set to cover it but the need to have charging points still limits the diffusion of these vehicle architectures in private transport [1-3]. For this reason, ICEs (Internal Combustion Engines) will remain the main propulsion system in the near future, for both conventional and hybrid architectures. The need to comply with the more and more stringent regulations in terms of carbon dioxide (main responsible of the global warming effect) and pollutant emissions has led the car manufacturers to develop innovative technologies for gasoline and diesel ICEs. Concerning diesel ICEs, Exhaust Gas Recirculation (EGR) and Variable Geometry Turbochargers (VGTs) [4], high pressure common rail injection systems [5-10], advanced combustion control and innovative combustion concepts [11] represent some of these technologies.

Among the unconventional combustion process, premixed charge compression ignition (PCCI) is an unconventional combustion strategy which, by means of an early pre-mixed charge and a high EGR ratio (up to 60%), allows NO_x

and PM to be reduced at the same time, even though high levels of combustion noise, HC and CO pollutant emissions are to be expected.

Other possibilities are represented by alternative fuels such as CNG (Compressed Natural Gas) and biofuels [12], innovative ATS (after-treatment systems) [13], engine downsizing [14] and technologies whose aim is to recover and store kinetic energy, such as regenerative braking or start and stop systems.

Emerging technologies are also autonomous driving and vehicle connectivity (V2X technologies), which are expected to lead to significant advantages in terms of safety and pollutant reduction [15]. These technologies can be coupled with model-based controllers of the powertrain.

Focusing on diesel engines, which are characterized by a high degree of complexity and a high number of actuators, the potentialities which are offered by advanced model-based combustion controllers, in terms of pollutant reduction, are interesting [16-18].

The diesel combustion process is, in fact, affected by a large number of parameters. Model-based controllers can help to manage these parameters and to reach desired targets of performance metrics or pollutant emissions by adjusting these parameters in real-time. Model-based combustion controllers can also lead to a more effective management of the ATS, for example by means of a real-time optimization of the injection strategy.

With reference to in-cylinder combustion control, in the last few years, research has been focusing on the development of sensor-based and model-based controllers which seem to have a good potential in terms of computational time, especially when compared to traditional map-based approaches.

This has been made possible by the recent advances in the computational performance of engine control units (ECUs) which are now capable of executing more and more complex algorithms in real time. This kind of controllers allows the engine variables to be adjusted in real time, in order to control the combustion process and the ATS so that desired pollutant emissions values and performance can be reached.

On the basis of the previous background, a real time model-based combustion controller is presented in this study, which is capable of setting the hydraulic start of injection (SOI_h) and the injected fuel mass quantity of the main pulse ($q_{f,main}$) to achieve desired targets of NOx and BMEP (brake mean effective pressure), respectively, for a 3.0L FPT F1C diesel engine for light-duty applications. The combustion model used in the controller was previously developed by the authors in [17-20] for passenger car and light/heavy-duty applications. However, the main novelty of this study consists in the testing and assessment of the controller by means of the MiL (Model-in-the-Loop) methodology, by coupling it to a GT-Power fast running model of the engine. This is a preliminary step to verify the functionality of the controller before the implementation in the real engine, which will be carried out in the near future.

MODEL-IN-THE-LOOP TESTS

The MiL tests that have been considered in the present paper include transient conditions carried out under conventional combustion mode.

In particular, load ramps (figure 1) have been performed for different engine speeds (1200, 2000 and 3000 rpm) to verify the functionalities of the controller in every operating condition:

- Controller ON or OFF
- Different values for the NOx target, considering appropriate offset values: 0, $\pm 20\%$ and $\pm 40\%$ with respect to the original target map values

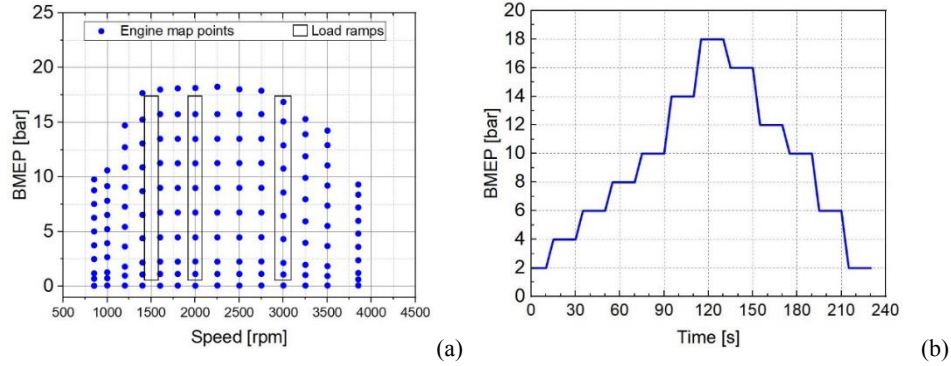

FIGURE 1. Engine map areas (a) covered through load ramps (b).

DESCRIPTION OF THE COMBUSTION MODEL

The scheme of the combustion model is shown in figure 2. The model was previously developed in [17] for the same engine, and it is based on a physics-based mean-value approach. Moreover, it features real-time capability when it is run on an ETAS ES910 rapid prototyping device [17].

The model is able to simulate the heat release rate and in-cylinder pressure, as well as the related combustion metrics. The heat release model is based on an enhanced version of the accumulated fuel mass approach [17]. NOx emissions are estimated using a recently developed model that is based on MFB50 (crank angle at which 50% of the fuel has burnt) [20].

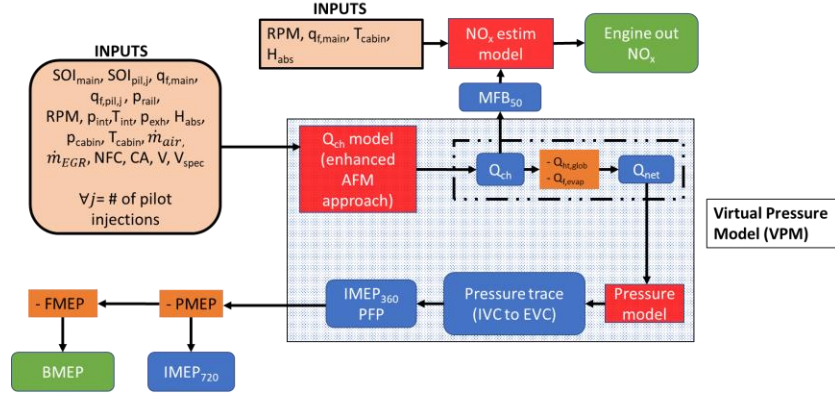

FIGURE 2. Scheme of the combustion model.

The details of each sub-model and the equations to determine all the parameters are presented in [16, 19].

MODEL-BASED CONTROLLER

This study focuses on the assessment of a model-based controller of BMEP and NOx emissions through MiL. The controller receives as input target values of BMEP and NOx emissions and corrects the values of the hydraulic start of injection and the fuel mass injected quantity of the main pulse in order to reach the desired targets. The controller computes the correction cycle-by-cycle for each firing cylinder starting from initial values of SOI_{main} and $q_{f,inj}$ that are given by the ECU, as showed by figure 3.

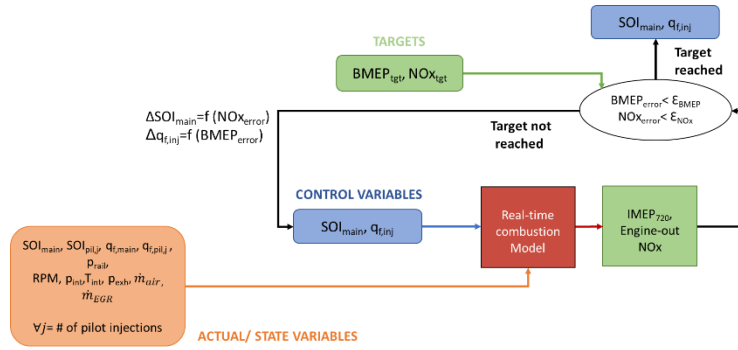

FIGURE 3. Model-based controller scheme.

For the sake of brevity, the iterative correction of SOI_{main} and $q_{f,inj}$ on the basis of NOx_{error} and $BMEP_{error}$ is only represented by figure 3 but is explained in detail in [17].

MODEL-IN-THE-LOOP SETUP

In the Model-in-the-Loop phase the controller was first developed in the Matlab/Simulink environment and then coupled with a fast-running (FR) GT-Power engine model to test its functionalities.

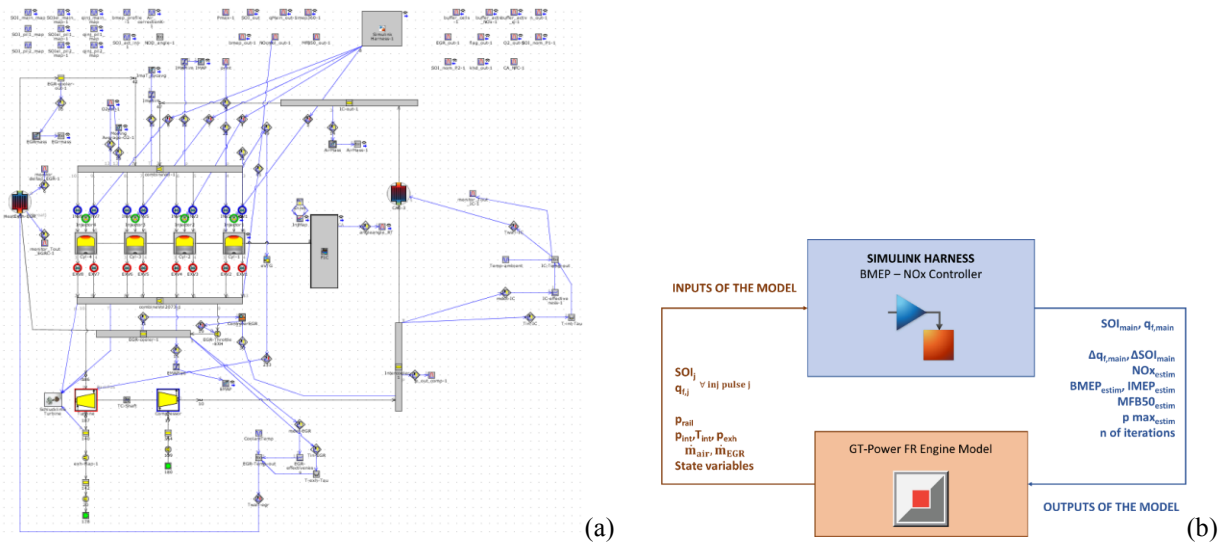

FIGURE 4. GT-Power FR engine model (a) with the scheme of the MiL coupling (b).

The GT-Power engine model, which is presented in fig. 4a, was considered instead of the detailed one in order to save computational time for testing since it has fewer number of pipes and simplified EGR cooler and intercooler systems with respect to the complete model, while the four cylinders are simulated with the same degree of detail, especially for what concerns the combustion objects.

In Fig. 4a it can be seen that the engine features a short-route EGR system, in which the desired EGR rate is set by a PID controller which acts on the EGR valve diameter. It can also be seen that the model includes a VGT controller, which acts on the rack position of the turbine (defining the orientation of the stator blades), in order to reach a desired value of boost pressure.

The controller, developed in Simulink, is coupled with the GT-power engine model through the GT-Power *Simulink Harness* block (Fig. 4b).

This block receives the inputs from the different objects of the FR model and sends, as outputs, the controlled variables, i.e., SOI_{main} and $q_{f,inj}$, which are passed to the injectors.

Focusing on Simulink Harness block (figure 4b), it receives the SOI and the $q_{f,inj}$ values of the three pulses into two different 3-element column vectors from look-up tables as functions of engine speed and BMEP, performs the corrections according to equations presented in [17] and sends the updated values to GT-Power back again in order to reach the target values of BMEP and NOx emissions.

Target values can be inserted either manually or through a proper offset parameter value included into several *Simulink parameters*.

RESULTS AND DISCUSSION

The model has been validated in transient conditions, considering the three load ramps reported in figure 1b for different values of engine speed in order to cover the whole engine map (figure 1a).

Figure 5 shows, for the three considered load ramps, the NOx trends for different engine speeds (1500, 2000, 3000 rpm). In particular, the NOx targets are reported with red lines, the NOx levels estimated by the controller (which should match the targets if the controller has achieved convergence) are reported with blue lines, while the actual NOx emissions deriving from the GT-power model are indicated with dark yellow lines. In general, the NOx targets are defined on the basis of a map as a function of engine speed and BMEP. An offset parameter can be used in order to increase/decrease the nominal NOx target by a defined percentage.

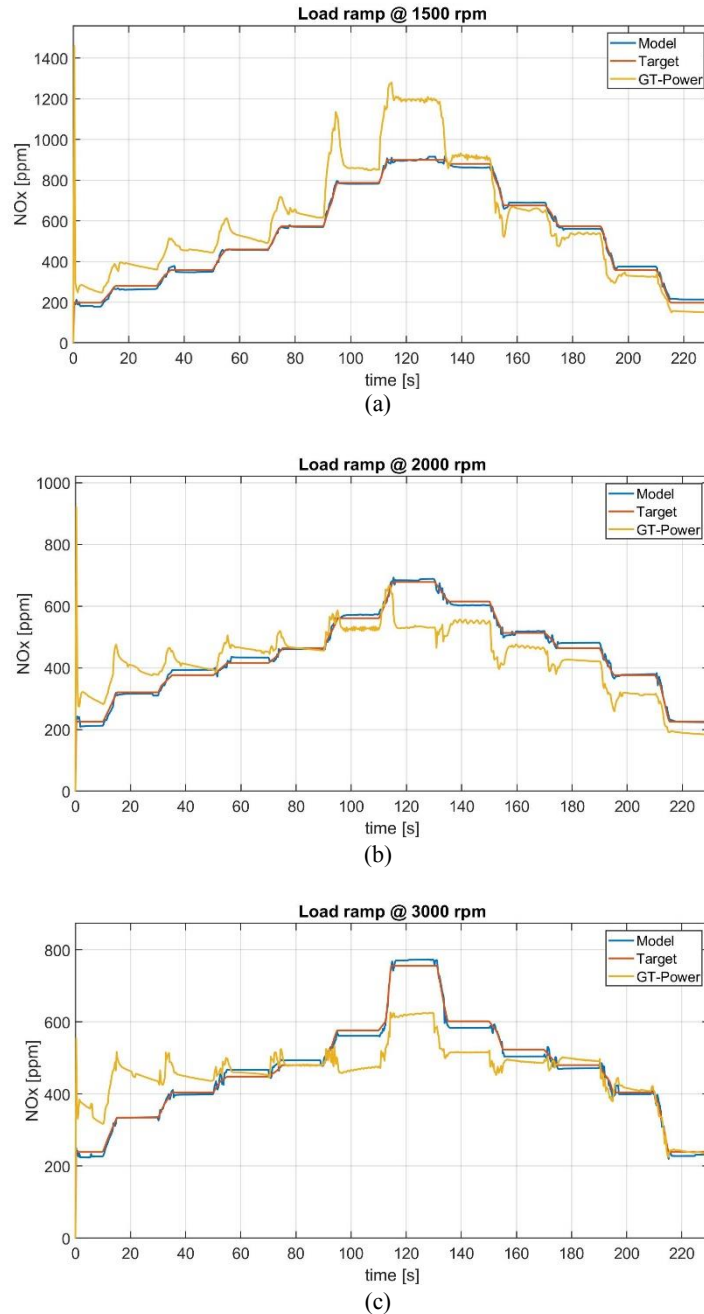

FIGURE 5. Time histories of NOx engine-out emissions @ 1500 rpm (a), 2000 rpm (b), 3000 rpm (c).

It can be seen in the figure that the functionality of the NOx controller has been verified. With reference to the accuracy of the controller, it should be noted that the sometimes a not negligible mismatch occurs between the target levels of NOx and the actual levels estimated by GT-Power. This mismatch can be partly attributed to inaccuracies of the real-time combustion model and partly to inaccuracies of the GT-Power model in estimating the NOx emissions. In fact, the real-time combustion model used for the controller was calibrated in [17] directly using the experimental data acquired on the real engine, and not using the data simulated by the GT-Power model. Therefore, this can introduce a misalignment between the two simulation approaches in terms of NOx emission prediction. The mismatch may also be related to a deviation between the actual EGR rate coming from the GT-Power simulation and the EGR rate

estimated by the model-based controller by means of its EGR sub-model. This leads to a deviation in the intake O₂ concentration estimation, with a consequent impact on NO_x control accuracy.

It can also be seen in the figure that some spikes occur for the actual levels of NO_x emissions deriving from the GT-Power model. These spikes are also likely to be related to the a mismatch between the actual EGR rate coming from the GT-Power model and the EGR rate estimated by the model-based controller, which is not able to capture the fast variations which occur during the transition between different engine operating points.

The mismatch may also be related to the use of a fast-running GT-Power model instead of a detailed one. However, the possible benefits deriving from the use of a detailed model could not be justified by the increase in the required computational time.

A significant advantage, also in view of the implementation of the controller in the real engine, could be constituted by the measurement of the intake oxygen concentration, to be provided directly as input to the model-based controller. Figure 6 shows the time histories of BMEP. Also in this case, three lines are represented: the BMEP targets are reported with red lines, the BMEP values estimated by the controller are reported with blue lines, while the actual BMEP levels deriving from the GT-Power model are indicated with dark yellow lines.

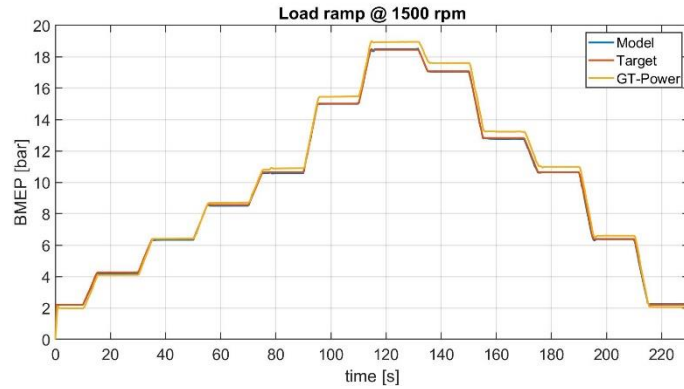

(a)

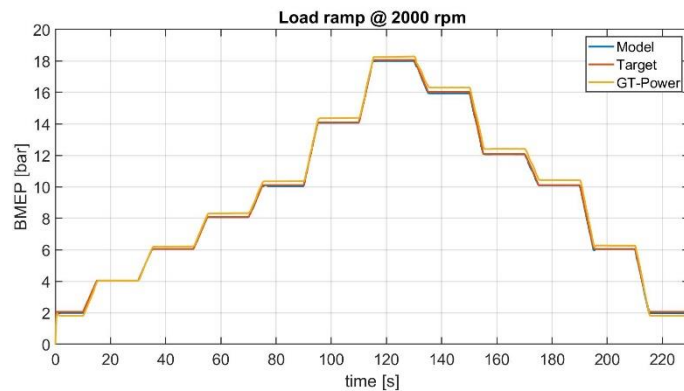

(b)

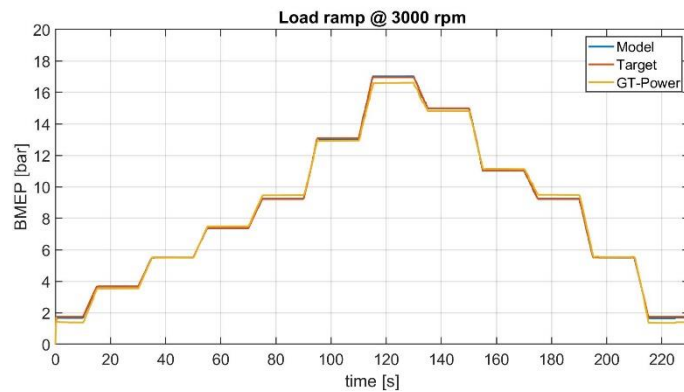

(c)

FIGURE 6. BMEP @ 1500 rpm (a), 2000 rpm (b), 3000 rpm (c).

Figure 6 shows that the functionality of the BMEP controller is verified.

Figure 7 reports, the trends of the SOI_{main} correction (ΔSOI_{main}) identified by the controller, with respect to the nominal values deriving from the baseline engine maps.

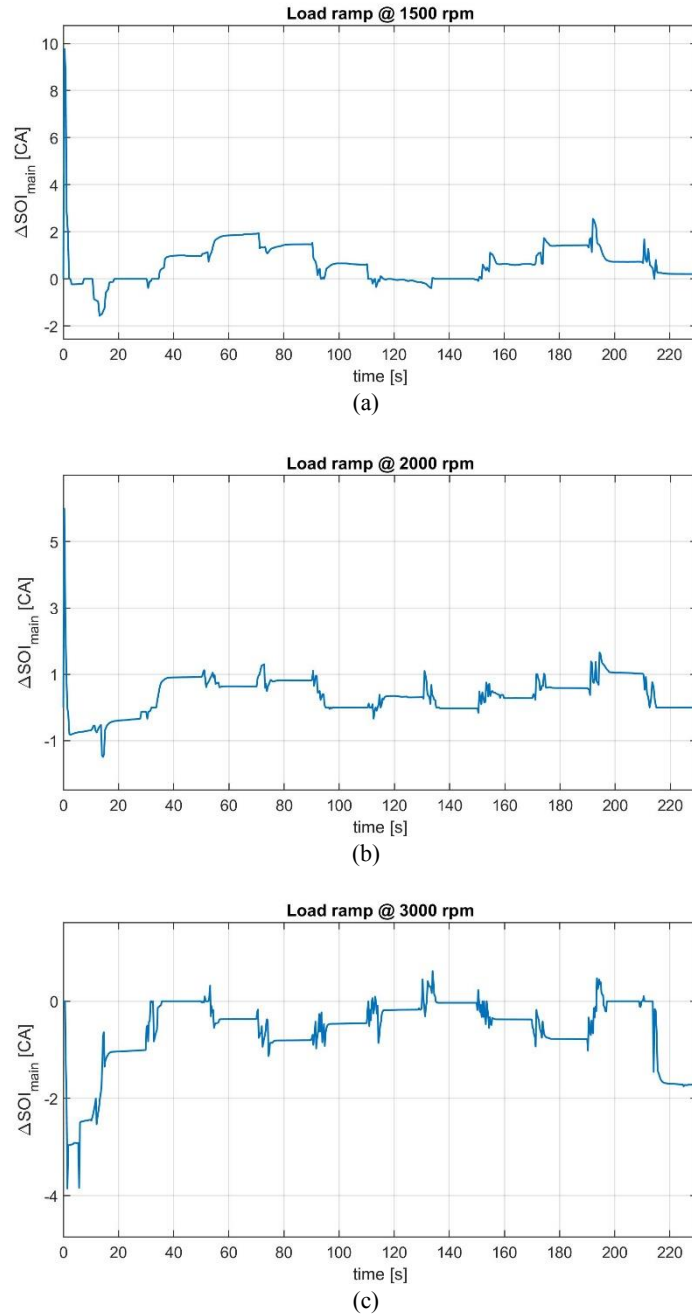
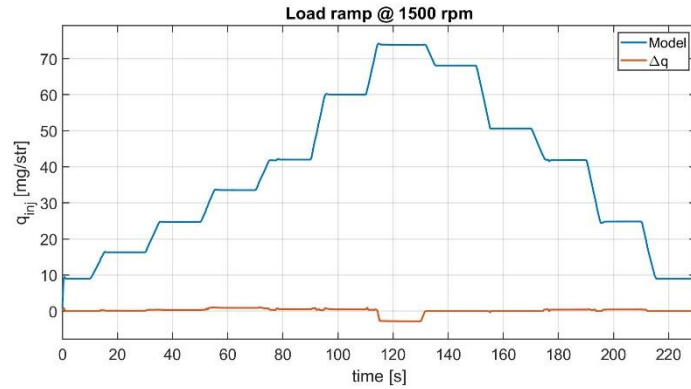

FIGURE 7. ΔSOI of the main pulse @ 1500 rpm (a), 2000 rpm (b), 3000 rpm (c).

ΔSOI values are strictly related to the graphs of figures 5: if, in fact, NO_x evaluated by the model are different from the target, the controller anticipates the injection in order to produce more NO_x emissions, while if the model produces higher emissions in terms of NO_x then the injection is delayed.

For the same ramps, figure 8 reports the injected fuel quantity of the main pulse, which is set by the controller, and the correction Δq with respect to the nominal value.



(a)

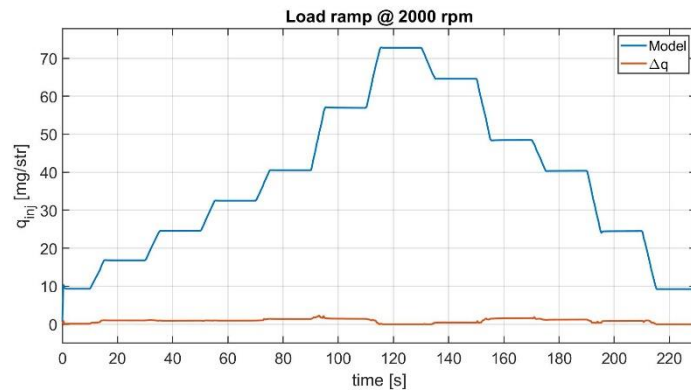

(b)

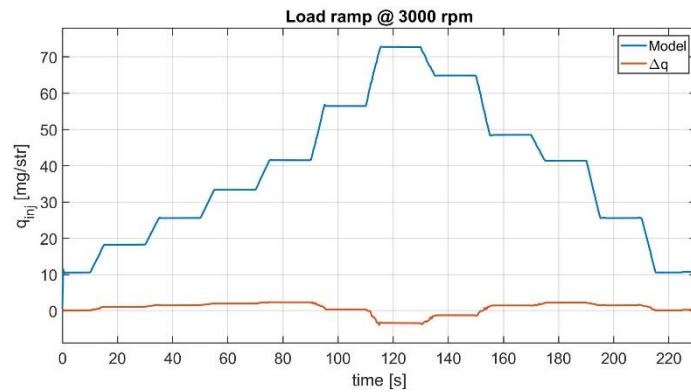

(c)

FIGURE 8. Fuel injected mass of the main pulse @ 1500 rpm (a), 2000 rpm (b), 3000 rpm (c).

Finally, the functionality of the controller has also been tested by introducing an offset with respect to the nominal one ($\pm 2\%$ and $\pm 4\%$ with respect to the map target values), and the results are shown in Fig. 9 in terms of NOx emissions estimated by GT-Power and SOI_{main} values. It can be seen that as NOx target values grow, the injection is anticipated.

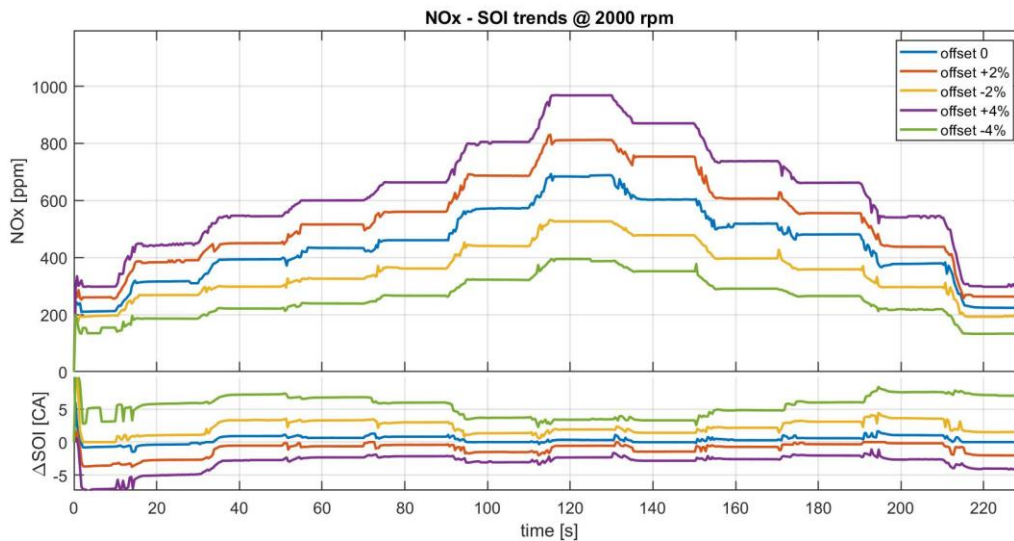

FIGURE 9. NOx – Δ SOI_{main} trends @ 2000 rpm for different NOx target values.

CONCLUSIONS

A model-based technique for the control of BMEP and NOx emissions has been developed and then tested through Model-in-the-Loop phase. The controller has been improved first in the Matlab/ Simulink environment and then coupled with a fast running GT-Power model of a 3.0L F1C FPT diesel engine for light-duty applications. The assessment of the functionalities of the controller has been carried out considering load ramps for different engine speeds in order to verify the response of the controller in all the cases, under conventional combustion mode. From the results, it was verified that the controller is effective in achieving a stable and effective control of both BMEP and NOx emissions. The controller is also very accurate concerning BMEP control, while some deviations occur between target and actual levels concerning NOx control. These deviations are mainly related to a mismatch between the actual intake O₂ concentration coming from the GT-Power engine model and the intake O₂ concentration estimated by the model-based controller by means of its internal EGR sub-model. A significant advantage, also in view of the implementation of the controller in the real engine through rapid prototyping, could be constituted by the measurement of the intake oxygen concentration, to be passed directly as input to the model-based controller.

Future activities will focus on tests on the real engine (Rapid Prototyping), by implementing an oxygen sensor installed in the intake manifold whose aim is to verify the response of the controller when dynamic effects of the intake oxygen percentage variation are taken into account.

REFERENCES

- [1] Finesso R, Misul D, Spessa E, Venditti M. Optimal Design of Power-Split HEVs Based on Total Cost of Ownership and CO₂ Emission Minimization. *Energies* 2018, 11, 1705. 10.3390/en11071705.
- [2] Finesso, R.; Spessa, E.; Venditti, M. Layout design and energetic analysis of a complex diesel parallel hybrid electric vehicle. *Applied Energy* 2014, 134, 573-588. 10.1016/j.apenergy.2014.08.007.
- [3] Finesso, R.; Spessa, E.; Venditti, M. Cost-optimized design of a dual-mode diesel parallel hybrid electric vehicle for several driving missions and market scenarios. *Applied Energy* 2016, 177, 366-383. 10.1016/j.apenergy.2016.05.080.
- [4] Baratta, M., Finesso R., Misul, D., Spessa E., “Comparison between Internal and External EGR Performance on a Heavy Duty Diesel Engine by means of a Refined 1D Fluid-Dynamic Engine Model”, *SAE International Journal of Engines* 8(5):2099-2119, 2015, doi: 10.4271/2015-24-2389.

- [5] Ferrari A., Mittica A., Pizzo P., Jin Z. "PID Controller Modelling and Optimization in Cr Systems with Standard and Reduced Accumulators", *International Journal of Automotive Technology* 19(5):771-781, 2018.
- [6] Ferrari A., Mittica A., Pizzo P., Wu X., Zhou H. "New methodology for the identification of the leakage paths and guidelines for the design of common rail injectors with reduced leakage", *Journal of Engineering for Gas Turbines and Power* 140(2), 2018.
- [7] Ferrari A., Mittica A., Paolicelli F., Pizzo P., "Hydraulic Characterization of Solenoid-actuated Injectors for Diesel Engine Common Rail Systems" *Energy Procedia* 101:878-885, 2016.
- [8] Catania A., Ferrari A., Mittica A., Spessa E. "Common rail without accumulator: Development, theoretical-experimental analysis and performance enhancement at DI-HCCI level of a new generation FIS", SAE Technical paper 2007-01-1258, 2007.
- [9] Catania A., Ferrari A., Mittica A. "High-pressure rotary pump performance in multi-jet common rail systems", Proceedings of 8th Biennial ASME Conference on *Engineering Systems Design and Analysis*, ESDA2006. Engineering Systems Design and Analysis, Volume 4: Fatigue and Fracture, Heat Transfer, Internal Combustion Engines, Manufacturing, and Technology and Society:557-565 doi: 10.1115/ESDA2006-95590.
- [10] Ferrari, A., Manno, M., Mittica, A. "Cavitation analogy to gasdynamic shocks: Model conservativeness effects on the simulation of transient flows in high-pressure pipelines", *Journal of Fluids Engineering, Transactions of the ASME*, 130(3): 031304, 2008. Doi: 10.1115/1.2842226
- [11] Xue, X. Rutledge, J. Potentials of Electrical Assist and Variable Geometry Turbocharging System for Heavy-Duty Diesel Engine Downsizing. *SAE Technical Paper 2017-01-1035*; SAE International: Warrendale, PA, USA, 2017; 10.4271/2017-01-1035.
- [12] D'Ambrosio S., Gaia, F., Iemmolo, D., Mancarella, A. et al. "Performance and Emission Comparison between a Conventional Euro VI Diesel Engine and an Optimized PCCI Version and Effect of EGR Cooler Fouling on PCCI Combustion", *SAE Technical Paper 2018-01-0221*, 2018. doi: 10.4271/2018-01-0221
- [13] Di Iorio, S., Beatrice, C., Guido, C., Napolitano, P. et al. Impact of Biodiesel on Particle Emissions and DPF Regeneration Management in a Euro5 Automotive Diesel Engine. *SAE Technical Paper 2012-01-0839*; SAE International: Warrendale, PA, USA, 2012; 10.4271/2012-01-0839.
- [14] Giakoumis, E.G. Diesel and Spark Ignition Engines Emissions and After-Treatment Control: Research and Advancements. *Energies* 2017, 10, 1882. 10.3390/en10111882.
- [15] Talavera, E.; Díaz-Álvarez, A.; Jiménez, F.; Naranjo, J.E., Impact on Congestion and Fuel Consumption of a Cooperative Adaptive Cruise Control System with Lane-Level Position Estimation. *Energies* 2018, 11, 194. 10.3390/en11010194.
- [16] Finesso, R., Marelllo, O., Misul, D., Spessa, E., Violante, M., Yang, Y., Hardy, G., Maier, C. Development and Assessment of Pressure-Based and Model-Based Techniques for the MFB50 Control of a Euro VI 3.0L Diesel Engine. *SAE Int. J. Engines* 2017, 10(4), 1538-1555, doi:10.4271/2017-01-0794
- [17] Finesso, R., Hardy, G., Marelllo, O., Spessa, E., Yang, Y. Model-Based Control of BMEP and NOx Emissions in a Euro VI 3.0L Diesel Engine. *SAE Int. J. Engines* 2017, 10(5), 10.4271/2017-24-0057.
- [18] Finesso, R., Spessa, E., Yang, Y., Conte, G., Merlino, G. Neural-Network Based Approach for Real-Time Control of BMEP and MFB50 in a Euro 6 Diesel Engine. *SAE Technical Paper 2017-24-0068*; SAE International: Warrendale, PA, USA, 2017, 10.4271/2017-24-0068.
- [19] Finesso R., Spessa E., Yang Y., Development and Validation of a Real-Time Model for the Simulation of the Heat Release Rate, In-Cylinder Pressure and Pollutant Emissions in Diesel Engines, *SAE Int. J. Engines* 2016, 9, 322-341. 10.4271/2015-01-9044.
- [20] Finesso R., Hardy G., Mancarella A., Marelllo O., Mittica A., Spessa E. Real-Time Simulation of Torque and Nitrogen Oxide Emissions in an 11.0 L Heavy-Duty Diesel Engine for Model-Based Combustion Control. *Energies* 2019; 12: 460. Doi: [10.3390/en12030460](https://doi.org/10.3390/en12030460).