

Speed of sound measurements in deuterium oxide (D<sub>2</sub>O) at temperatures between (276.97 and 363.15) K and at pressures up to 210MPa

*Original*

Speed of sound measurements in deuterium oxide (D<sub>2</sub>O) at temperatures between (276.97 and 363.15) K and at pressures up to 210MPa / Lago, S.; Giuliano Albo, P. A.; Cavuoto, G.. - In: FLUID PHASE EQUILIBRIA. - ISSN 0378-3812. - (2019), p. 112401. [10.1016/j.fluid.2019.112401]

*Availability:*

This version is available at: 11583/2768303 since: 2019-11-20T12:34:48Z

*Publisher:*

Elsevier

*Published*

DOI:10.1016/j.fluid.2019.112401

*Terms of use:*

This article is made available under terms and conditions as specified in the corresponding bibliographic description in the repository

*Publisher copyright*

Elsevier postprint/Author's Accepted Manuscript

© 2019. This manuscript version is made available under the CC-BY-NC-ND 4.0 license  
<http://creativecommons.org/licenses/by-nc-nd/4.0/>. The final authenticated version is available online at:  
<http://dx.doi.org/10.1016/j.fluid.2019.112401>

(Article begins on next page)

# Journal Pre-proof

Speed of sound measurements in deuterium oxide (D<sub>2</sub>O) at temperatures between (276.97 and 363.15) K and at pressures up to 210 MPa

S. Lago, P.A. Giuliano Albo, G. Cavuoto

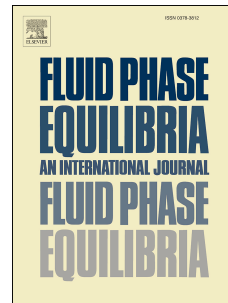

PII: S0378-3812(19)30463-7

DOI: <https://doi.org/10.1016/j.fluid.2019.112401>

Reference: FLUID 112401

To appear in: *Fluid Phase Equilibria*

Received Date: 7 August 2019

Revised Date: 7 November 2019

Accepted Date: 11 November 2019

Please cite this article as: S. Lago, P.A. Giuliano Albo, G. Cavuoto, Speed of sound measurements in deuterium oxide (D<sub>2</sub>O) at temperatures between (276.97 and 363.15) K and at pressures up to 210 MPa, *Fluid Phase Equilibria* (2019), doi: <https://doi.org/10.1016/j.fluid.2019.112401>.

This is a PDF file of an article that has undergone enhancements after acceptance, such as the addition of a cover page and metadata, and formatting for readability, but it is not yet the definitive version of record. This version will undergo additional copyediting, typesetting and review before it is published in its final form, but we are providing this version to give early visibility of the article. Please note that, during the production process, errors may be discovered which could affect the content, and all legal disclaimers that apply to the journal pertain.

© 2019 Published by Elsevier B.V.

Speed of sound measurements in deuterium oxide (D<sub>2</sub>O)  
at temperatures between (276.97 and 363.15) K and at  
pressures up to 210 MPa

S. Lago<sup>1,\*</sup>, P. A. Giuliano Albo<sup>1</sup>, G. Cavuoto<sup>1</sup>

*Istituto Nazionale di Ricerca Metrologica, Strada delle Cacce 91, 10135 Torino, Italy*

---

**Abstract**

This paper presents speed of sound measurements in heavy water (deuterium oxide, D<sub>2</sub>O) along six isotherms between 276.97 K and 363.15 K for pressures up to 210 MPa using a double *pulse-echo* method. The experimental apparatus was validated measuring the speed of sound in ordinary water at ambient pressure and at temperatures between 295.5 K and 363.15 K with results found in agreement with values calculated from the reference equation of state for water by Wagner and Pruß within 0.005 %. The relative combined expanded uncertainty of our speed of sound measurements, at a confidence level of 95 %, is estimated to be less than 0.03 % for pressures up to 10 MPa and in the order of 0.05 % for pressures up to 210 MPa in the whole investigated temperature range. The speed of sound results have been compared with values calculated from the reference equation for heavy water the IAPS84 Formulation by Hill et al. (1982), and with the prediction of the newly developed equation of state for heavy water by Herrig *et al.* (2018). The relative deviations of these comparison were found to be consistent with the reference equations within their combined uncertainty. The results presented here were also compared with the most recent data by Wegge *et al.* and found to be in agreement within 0.05 %.

*Keywords:* Speed of sound, deuterium oxide, heavy water, high pressure

---

---

\*Corresponding author

*Email address:* s.lago@inrim.it (S. Lago)

## 1. Introduction

Liquid deuterium oxide (often referred to as heavy water) is of interest in various scientific fields for its numerous applications, e.g. to study mechanisms and rates of chemical or nuclear reactions, for diagnostics in nuclear magnetic resonance, as well as in biological processes and as coolant and moderator in pressurized heavy-water reactor (PHWR) of nuclear power plants. A dedicated equation of state (EoS) is a useful tool to represent the ensemble of thermodynamic properties needed to develop novel technological and industrial solutions. The dedicated EoS of a fluid can reach high accuracy when also caloric properties (such as speed of sound and specific heat capacity) are included in its implementation. High pressure speed of sound measurements are of special interest because, being linked to both calorific and mechanical properties of the fluid, they drive the choice of the number of terms that are included in the equation of state and allow to improve its accuracy, and the physical behaviour. Differently from the case of water, the thermodynamic properties of heavy water are far less studied and measurements are usually affected by a larger uncertainty. The measurement accuracy significantly improves for atmospheric pressure measurements and a complete list of references of these measurements is reported in Table 13 of Herrig *et al.*[1] Anyway, since in this work the minimum pressure has been limited to 0.2 MPa (for preventing the possible contamination of the fluid), a direct comparison with the results reported at 0.1 MPa is not possible, unless by extrapolation.

Considering high pressure speed of sound measurements the availability of published papers reduces to few works. In this case, mention is worth for the speed of sound results obtained by Wilson [2] or by Chen and Millero [3] up to 100 MPa, those obtained by Aleksandrov and Larkin [4], and the very accurate values by Wegge, Richter and Span (2016)[5]. Some of these data have been used by Hill *et al.*[6] to implement a fundamental equation of state, anyway that equation has a limited range of validity with a lower limit temperature of 276.97 K and a maximum pressure of 100 MPa. More recently, a more accurate

reference equation of state has been implemented by Herrig *et al.* [1], but a definitive uncertainty estimation for pressures above 100 MPa is not possible, because speed of sound data were not available in this high pressure region. Motivated by this limited framework, we carried out more than seventy experimental speed of sound measurements in heavy water (deuterium oxide, D<sub>2</sub>O; purity: 99.85 % D atoms, deuterium atoms fraction), as reported and discussed in the rest of this work. Our experimental results have been obtained along six isotherms ranging from (276.97 to 363.15) K and for pressure up to 210 MPa. The results presented here are the only data available in this range of pressure, making them useful to improve and update a new dedicated equation of state [1] or, at least, they contribute to validate the equation and provide an estimation of its accuracy when thermodynamic properties are extrapolated.

## 2. Experimental Section

Speed of sound was measured by a double *pulse-echo* ultrasonic technique. The core of the experimental apparatus, used for the determination of the phase velocity of the ultrasonic waves, is a cylindrical stainless steel cell supplied with two reflectors placed at unequal distances from a single piezoelectric transducer. The main features of the apparatus design (with regard to the dimensions, constructing materials, gaskets, and because of the absence of moving parts) make it a versatile instrument which can be operated over a wide range of temperatures and pressures. The double *pulse-echo* method is based on direct measurement of the time delay between echoes coming from the different reflectors. In a previous paper [7], details about the ultrasonic cell and the associated experimental apparatus are provided. The adopted measurement design allows to compensate the effects due to the trigger and electrical line delays but, even more importantly, this configuration allows to obtain a repeatability of the time-of-flight measurements in the order of 10 parts per million since tone bursts have very similar shapes. In figure 1, a geometrical sketch of the measurement cell is shown. The nominal lengths of the spacers, separating the source (red) from the reflectors are  $L_1 = 45$  mm and  $L_2 = 67.5$  mm. The acoustic path length

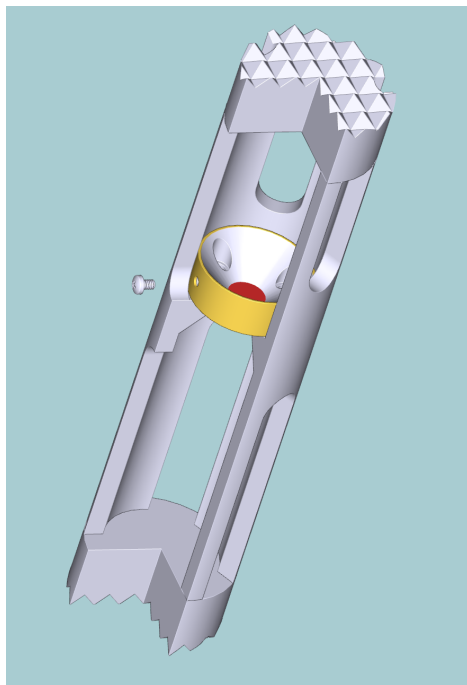

Figure 1: Layout of the ultrasonic measuring sensor[10].

was estimated by the results of a calibration based on speed of sound measurements in high-purity ordinary water ( $\text{H}_2\text{O}$ ) at seven different temperatures (295.5, 303.15, 304.0, 319.0, 323.15, 343.15, 363.15) K and ambient pressure, with reference speed of sound values obtained from the IAPWS-95 formulation [8].

Additional experimental tests have been carried out to verify that calibrated  $\Delta L$  ( $\Delta L = L_2 - L_1$ ) did not vary, depending on the carrier frequency adopted to generate the signal. Three different runs have been performed using tone-burst of 5 cycles with a carrier frequency of 4 MHz and three additional runs with a carrier frequency of 8 MHz. Since the frequency dependence of the time-of-flight has been verified to be negligible, when compared to other sources of uncertainty, the speed of sound measurements were eventually performed at 4 MHz. To minimize the effect of temperature drifts in the order of a few millikelvin, the calibration has been repeated three times and the results have

$p = 0.1$ MPa $T = 294.95$ K	$2\Delta L / \text{mm}$ Calibration 1 (3 runs)	$2\Delta L / \text{mm}$ Calibration 2 (3 runs)	Relative deviations	$2\Delta L / \text{mm}$ Mean value
$f = 4$ MHz	43.8029	43.8017	0.0026 %	43.8023
$f = 8$ MHz	43.8047	43.8037	0.0022 %	43.8042
Relative deviation				0.0043 %

Table 1: Results of the cell calibration procedure obtained using different carrier frequencies.

been averaged. All these preliminary tests were carried out at ambient pressure and  $T = 294.95$  K. The results have been summarized in Table 2. In figure 2 the overlapping of the two echoes (black and gray) obtained at 4 MHz (a) and at 8 MHz (b) are shown.

The relative deviations of our experimental results ( $w_{\text{INrIM}}$ ) from  $w_{\text{EoS}}$ , such as the speed of sound values calculated with the equation of state (EoS) of Wagner and Pruß [8], are plotted as a function of the temperature in figure 3. The uncertainty declared by Wagner and Pruß for the speed of sound predicted by equation, in the specific considered region, is only 0.005 %. Remarkably, all our experimental results are in a good agreement with the reference equation of state.

The piezoelectric transducer is excited with an electrical signal from a function generator in the form of five-cycles repeated tone-bursts with a carrier frequency of 4 MHz and an amplitude of 10 Vpp. The waveforms, including both echoes, have a duration of approximately 100  $\mu\text{s}$  and are digitized at a sampling rate of  $4 \times 10^9$  samples per second. By analyzing the sampled signals, the time-of-flight  $\tau_{\text{exp}}$  of the ultrasonic waves that travelled twice the distance separating the source and reflectors is determined. The speed of sound,  $w_{\text{exp}}$ , is then obtained from the following expression:

$$w_{\text{exp}} = \frac{2\Delta L}{\tau_{\text{exp}}}, \quad (1)$$

where  $\Delta L$  is the difference in the acoustic paths travelled by the first two echoes coming from different reflectors and  $\tau_{\text{exp}}$  is the corresponding time delay. The time delay is determined on the basis of the digital signal  $P_1(t)$ , representing

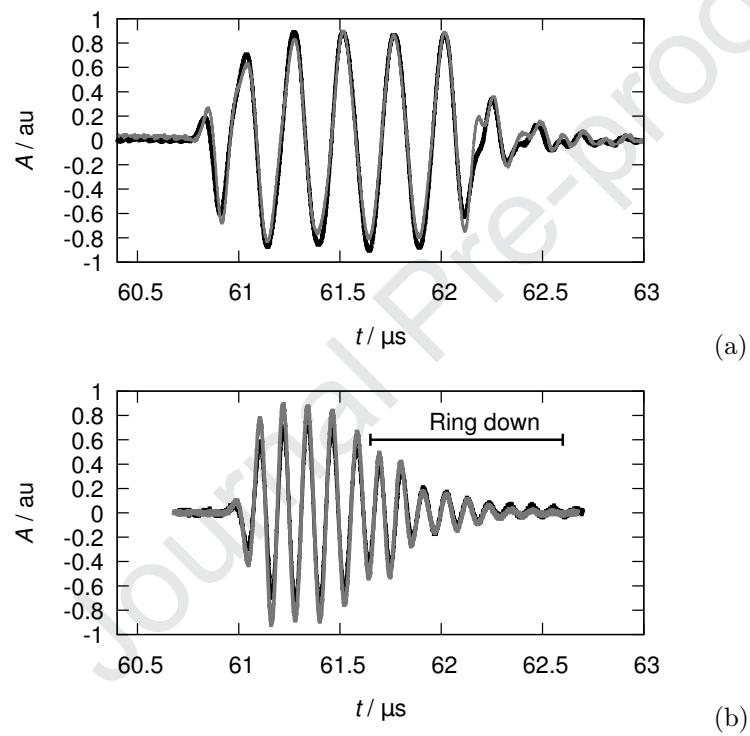

Figure 2: Plots of the five-cycles tone-bursts obtained with a 4 MHz carrier frequency (a) and 8 MHz (b) using a wide-band piezoelectric source with nominal resonant frequency of 8 MHz.



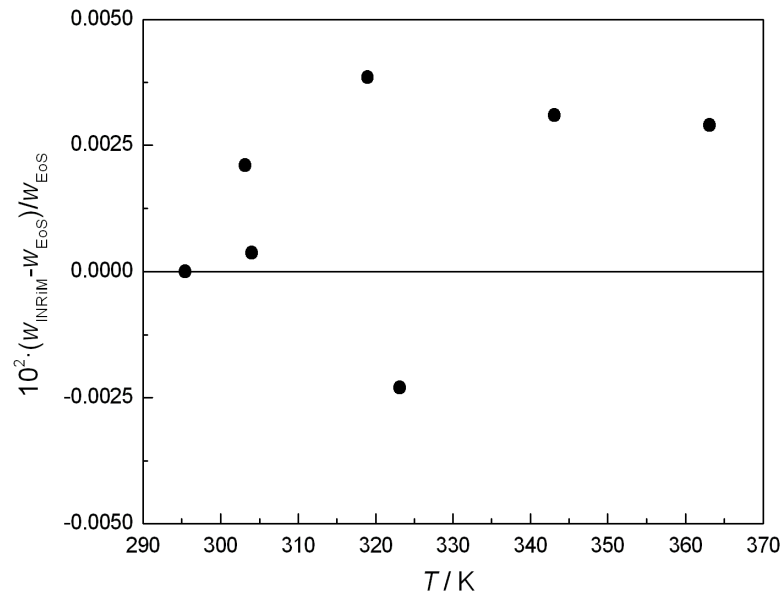

Figure 3: Results of the calibration of the speed of sound sensor in ordinary (light) water at  $p = 0.098$  MPa. Relative deviations of experimental speeds of sound  $w_{\text{INRiM}}$  from values  $w_{\text{EoS}}$  calculated with the EoS of Wagner and Pruf [8] are plotted as a function of the temperature  $T$

the first sampled echo from the nearest reflector, and the echo  $P_2(t + \tau)$ , from the farthest reflector, by means of a correlation function  $C(\tau)$  defined as:

$$C(\tau) = \int_{-\infty}^{\infty} P_1(t)P_2(t + \tau)dt, \quad (2)$$

that has the property to show an absolute maximum at the value of  $\tau$  equal to the time delay between the two echo waveforms. A detailed explanation of this method and the associated signal-to-noise ratio are discussed in Benedetto *et al.* [7].

Experimental measurements of times-of-flight and travelled path-lengths can be used to determine the speed of sound after keeping into account relevant corrections. In Lago *et al.* [9], it is shown how the finite dimensions of the source prevent the complete cancellation of the phase shift affecting the wavefronts spreading into the measurement cell. The described diffraction effects perturb the measurement of the time-of-flight, which is accounted by correcting the expression used to determine the speed of sound as follows:

$$w_{\text{exp}} = \frac{2\Delta L}{\tau_{\text{exp}} + \delta\tau}, \quad (3)$$

where the correction term  $\delta\tau$  comes from the wave-like nature of the spreading signal. The diffraction of the generated signal appears in the form of a phase advance of the ultrasonic pulses, relative to a perfectly plane wave traversing the same distance with resulting effects on  $\delta\tau$  which can be calculated using an appropriate model[9].

For speeds of sound, measured at temperature  $T$  and pressure  $p$  which differ from the calibration conditions  $(p_0, T_0)$ , the acoustic paths  $L_1$  and  $L_2$ , and their difference  $\Delta L$ , have to be corrected using the thermal expansion coefficient  $\alpha$  and compressibility coefficient  $\beta$  of the AISI-316L (namely the material comprising the measuring cell), according to the following relation:

$$\Delta L(p, T) = \Delta L(p_0, T_0) [1 + \alpha(T - T_0) - \beta/3(p - p_0)]. \quad (4)$$



Figure 4: Wide-band ceramic PZT “DuraAct” kapton encapsulated.

The wide-band ceramic PZT “DuraAct” kapton encapsulated, shown in figure 4 and used both as the source and the receiver of the acoustic signals, has a diameter of about 10 mm and is clamped by conical reflectors that reduce its effective radius to about 7 mm without changing the thickness of the disc; as a matter of fact, the nominal resonant frequency of 8 MHz is not perturbed by this type of clamping, as demonstrated by the long ring down time shown in figure 2(b).

The ultrasonic cell is set in an AISI-316L pressure vessel that can operate in the temperature range between (240 and 420) K and for pressures up to 300 MPa, sealed with AISI-316L metallic gaskets. Depending on the pressure range, one of three Honeywell pressure transducers with full-scale ranges of (10, 50, and 300) MPa was used, while the temperature is measured by means of two PT100 thermometers inserted in the top and the bottom ends of the pressure vessel. These thermometers were calibrated in the range of (230 and 390) K by comparison with INRiM’s (Istituto Nazionale di Ricerca Metrologica) Standard Platinum Resistance Thermometer (SPRT) directly traceable to the National Temperature Standard.

A liquid bath thermostat maintains the temperature of experiment with a long term stability better than  $\pm 1$  mK, over the whole working range, and is composed by a primary external thermostat that can reach a stability of 10 mK and a secondary Proportional Integrative and Derivative control (PID), providing feedback to achieve a finer temperature control.

### 2.1. Preparation of the apparatus

Speed of sound measurements along six isotherms at temperatures of (276.97, 283.15, 303.15, 323.15, 343.15, 363.15) K have been carried out. For each isotherm, measurements were taken starting at the pressure of 210 MPa and decreasing the pressure down to low pressure. The high pressure control system has been initially cleaned using volatile solvents and evacuated. Then, the entire high pressure manifold was rinsed with heavy water and subsequently drained and dried by a flow of compressed dry nitrogen several times. The system was then evacuated for 24 h by a trapped mechanical pump, to eliminate any residual trace of fluid and/or air. In order to prevent the possible contamination of the sample and the influence of dissolved gases, the pressure vessel, containing the ultrasonic cell, was filled under vacuum, by extraction of pure deuterium oxide from an ambient pressure reservoir. Successively, the system was filled at the maximum planned pressure, with the purpose of tensioning the main seal of the pressure vessel, while it was immersed in the thermostatic bath. After loading the measuring system with the sample, it was necessary to wait about 8 h to ensure that thermodynamic equilibrium has been reached. Pressure decrements along one isotherm were carried out slowly, taking care not to exceed a decrease rate of 0.1 MPa/s, to preserve the validity of the calibration of the pressure transducers. Following each successive pressure decrease, a temporary cooling of the liquid in the cell of about 10 mK was observed. This temperature change was recovered, by the action of the thermostatic bath, in about one hour. The completion of this transitory phase was observed by continuous monitoring the time-of-flight within the ultrasonic cell and by the temperature readings of the two thermometers. When measurements on an isotherm were completed, changes of about 10 K were brought to the system in preparation for the next isotherm. In optimal conditions, the thermodynamic equilibrium could be recovered after approximately 12 h.

The sample of deuterium oxide ( $D_2O$ ) was supplied by Sigma-Aldrich. The declared specific mole fraction purity of this sample was better than 99.9 % D atoms. No further analysis or purification was attempted. Some cautions have been

<b>Product name:</b>	Deuterium Oxide, 99.9 % D atoms	<b>Molecular Formula:</b>	D <sub>2</sub> O
<b>Molecular Weight:</b>	20.03	<b>Assay (Quantitative NMR):</b>	99.90 % D atoms
<b>Appearance (color):</b>	colourless	<b>Appearance (form)</b>	Liquid

Table 2: Specification of the used sample as reported by the certificate of analysis.

taken to try to preserve the purity of the sample. For example, to limit the contamination due to air humidity, bottles have been opened in a climatic room with relative humidity, at ambient temperature, below 20 % and sealed with a valve immediately afterwards. Specification of the used D<sub>2</sub>O sample has been reported in table 2, as declared by the supplier. Despite taken precautions, density changes have been observed when the sample has been analyzed after speed of sound measurements had been carried out. For this reason, the speed of sound results have been associated to a composition in between the two compositions (99.85 % D atoms) and a further contribution to the uncertainty budget has been added for accounting of the uncertainty of the sample composition.

### 3. Speed of sound results and comparison with equation of state predictions

Speed of sound measurements in heavy water were carried out in the temperature range from (276.97 to 363.15) K and pressures up to 210 MPa. The repeatability of the measurements has been checked for the isobar at 100 MPa, resulting in the order of 0.002 %. The relative combined expanded uncertainty ( $k = 2$ ) for the speed of sound measurements was estimated to be between 0.03 % and 0.05 %. Since one of the most important contribution to the speed of sound uncertainty comes from imperfect estimate of the experimental pressure, the budget has been separately prepared to consider a low pressure range with  $p < 10$  MPa and a high pressure range with  $10 < p/\text{MPa} < 210$  as reported in table 3.

Speed of sound measurements have been carried out along six isotherms. The distribution of the experimental pressure along all these isotherms is not the same. Table 4 lists the experimental speed of sound results, while figure 5 and 6 show the corresponding plots, as a function of pressure and temperature,

Source of uncertainty	Relative uncertainty ( $p < 210$ MPa)	Relative uncertainty ( $p < 10$ MPa)
Acoustic path length	0.0065 %	0.006 %
Time-of-flight	0.0010 %	0.001 %
Temperature	0.0070 %	0.007 %
Pressure	0.0197 %	Negligible
Repeatability	0.0020 %	0.002 %
Purity ( 99.85 % D atoms)	0.0070 %	0.007 %
Overall expanded uncertainty ( $k = 2$ )	0.051 %	<0.03 %

Table 3: Contributions to the standard uncertainty of speed of sound measurements calculated including the corresponding sensitivity coefficients.

respectively.

$T / \text{K}$	$p / \text{MPa}$	$w_{\text{exp}} / \text{m s}^{-1}$
276.97	0.93	1322.00
276.97	2.03	1323.39
276.97	4.01	1326.00
276.97	10.02	1334.18
276.97	30.00	1363.01
276.96	50.04	1394.37
276.97	70.00	1427.23
276.98	99.94	1478.17
276.98	99.95	1478.35
276.97	130.06	1529.92
276.97	160.05	1580.62
276.97	180.07	1614.23
276.98	199.95	1646.91
276.97	209.97	1663.14
277.15	209.95	1663.78
283.16	0.16	1347.86
283.16	10.03	1361.68
283.16	30.01	1391.17
283.15	50.01	1422.20
283.16	69.98	1454.32
283.16	99.98	1503.65
283.16	130.11	1553.42
283.14	159.99	1602.33
283.13	180.08	1634.58
283.15	200.35	1666.55
283.16	210.39	1682.30
303.15	0.21	1412.35
303.15	10.05	1427.41

$T / \text{K}$	$p / \text{MPa}$	$w_{\text{exp}} / \text{m s}^{-1}$
303.15	30.10	1458.55
303.15	49.98	1489.48
303.15	70.07	1520.73
303.15	100.09	1567.31
303.16	129.92	1612.94
303.15	160.09	1658.46
303.16	180.06	1688.03
303.16	190.72	1703.52
303.15	200.11	1717.13
303.15	209.88	1731.26
323.15	0.24	1447.45
323.15	10.07	1463.63
323.15	29.99	1496.13
323.15	50.05	1528.18
323.15	69.96	1559.43
323.15	100.09	1605.79
323.15	130.02	1650.63
323.15	160.06	1694.30
323.15	180.22	1723.07
323.15	200.07	1750.88
323.15	210.16	1764.70
343.15	0.24	1460.86
343.15	10.15	1478.45
343.13	30.08	1512.94
343.14	30.11	1513.02
343.14	50.01	1546.28
343.15	70.09	1578.75
343.15	100.16	1626.01



$T / \text{K}$	$p / \text{MPa}$	$w_{\text{exp}} / \text{m s}^{-1}$
343.15	129.99	1671.09
343.15	160.08	1714.78
343.15	180.27	1743.34
343.15	200.09	1770.97
343.15	209.75	1784.21
363.15	0.24	1457.29
363.15	10.06	1476.36
363.15	29.98	1513.27
363.15	49.91	1548.69
363.14	70.05	1583.21
363.15	100.05	1632.00
363.14	130.06	1678.67
363.14	160.10	1723.09
363.15	180.16	1751.88
363.15	200.12	1779.84
363.15	209.90	1792.96

Table 4: Speed of sound experimental values ( $w_{\text{exp}}$ ) in  $\text{D}_2\text{O}$  as a function of the temperature and pressure. The overall expanded relative uncertainty ( $k=2$ ) of the experimental results is  $u(w_{\text{exp}}) = \pm 0.03 \%$  for pressure below 10 MPa and  $u(w_{\text{exp}}) = \pm 0.05 \%$  for pressure above 10 MPa.

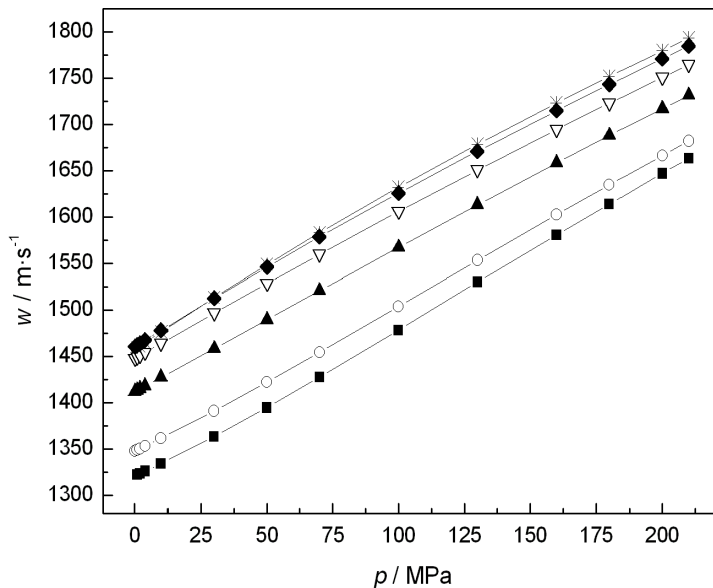

Figure 5: Speed of sound results in deuterium dioxide as a function of pressure. Measurements are affected by an expanded relative uncertainty ( $k = 2$ ) of 0.03 % for pressure up to 10 MPa and 0.05 % at higher pressure. Results are shown by isotherms: (■) 276.97 K; (○) 283.15 K; (▲) 303.15 K; (▽) 323.15 K; (◆) 343.15 K; (\*) 363.15 K.

Figure 5 shows intersecting isotherms (343.15 K and 363.15 K); this is expected since the pressure derivative of  $w$  significantly varies at low pressure for temperatures higher than  $\sim 348$  K. The characteristic shift of the speed of sound maximum value towards higher temperatures, for increasing pressure, is shown in figure 6. All the measurements along the isotherms have been carried out down to a minimum pressure of 0.2 MPa with the exception of the one at 276.97 K which was limited to 1 MPa.

The experimental results obtained in this work were not used to implement the today most updated fundamental equation of state for heavy water (IAPWS-2017) by Herrig *et al.* [1] and maintained by the International Association for the Properties of Water and Steam. Considering that the here obtained speed of sound measurements carried out are independent from those formulations, the

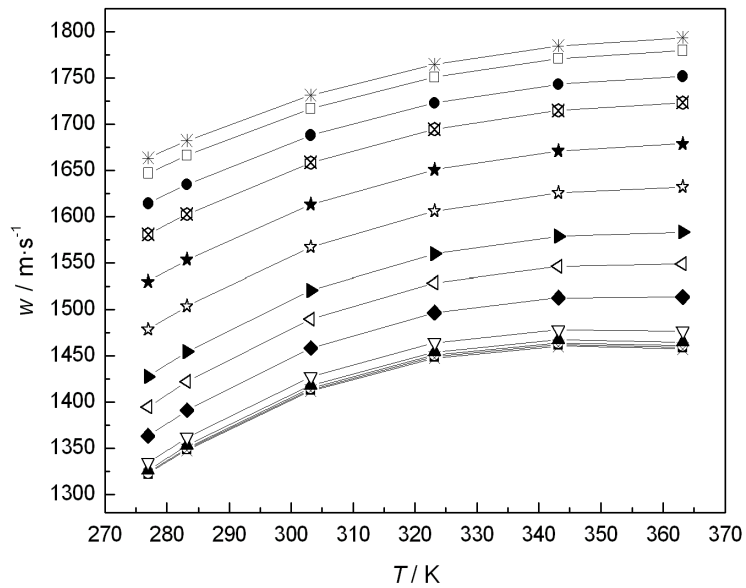

Figure 6: Speed of sound results in deuterium dioxide as a function of temperature. Measurements are affected by an expanded relative uncertainty ( $k = 2$ ) of 0.03 % for pressure up to 10 MPa and 0.05 % at higher pressure. Results are shown by isobars: (x) 0.1 MPa; (■) 1 MPa; (○) 2 MPa; (▲) 4 MPa; (▽) 10 MPa; (◆) 30 MPa; (◁) 50 MPa; (▶) 70 MPa; (☆) 100 MPa; (★) 130 MPa; (⊗) 160 MPa; (●) 180 MPa; (□) 200 MPa; (\*) 210 MPa

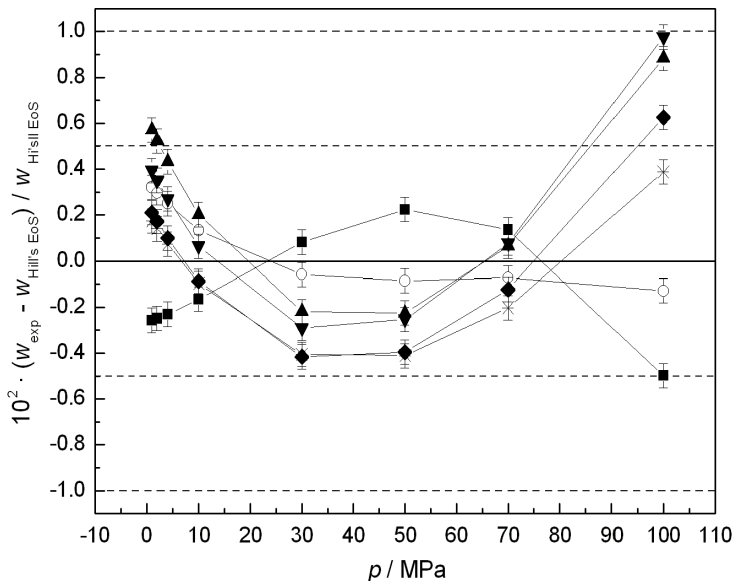

Figure 7: Relative deviation of experimental speed of sound results from Hill's equation of state. This equation has a declared relative uncertainty on speed of sound predictions of 1 % for temperature up to 350 K and 0.5 % above. Symbols correspond to (■) 297.97 K; (○) 283.15 K; (▲) 303.15 K; (▼) 323.15 K; (◆) 343.15 K; (\*) 363.15 K. Reported results are affected by an expanded relative uncertainty ( $k = 2$ ) of 0.03 % for pressure to 10 MPa and 0.05 % at higher pressure.

comparison with IAPWS-2017 predictions and with the previous equation by Hill *et al.* [6], gives an insight into improvements made by updating the equation and on whether the most recent can be further improved.

The relative deviations of our speed of sound from the values calculated with the IAPS84 formulation of Hill *et al.* [6] and with those calculated with a newly developed equation of state for heavy water by Herrig [1] are illustrated in figures 7 and 8, respectively.

For temperatures considered in the present work, the latter equation[1] declares 0.015 % in the pressure range from (0.1 to 20) MPa, 0.02 % for  $20 < p/\text{MPa} < 50$  and 0.1 % for  $50 < p/\text{MPa} < 100$ . For pressure above 100 MPa the uncertainty has not been declared since speed of sound values were obtained

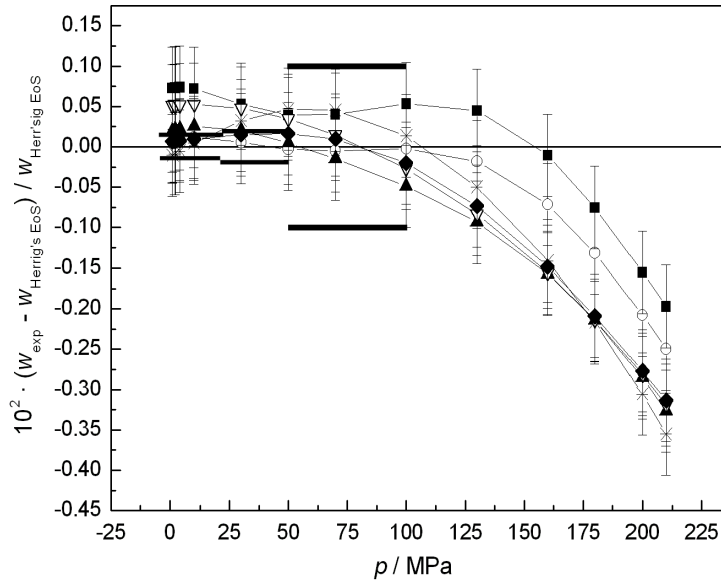

Figure 8: Relative deviation of experimental speed of sound measurements from Herrig's EoS. Reported results are affected by an expanded relative uncertainty ( $k = 2$ ) of 0.03 % for pressure up to 10 MPa and 0.05 % at higher pressure. Symbols correspond to (■) 297.97 K; (○) 283.15 K; (▲) 303.15 K; (▽) 323.15 K; (◆) 343.15 K; (\*) 363.15 K.

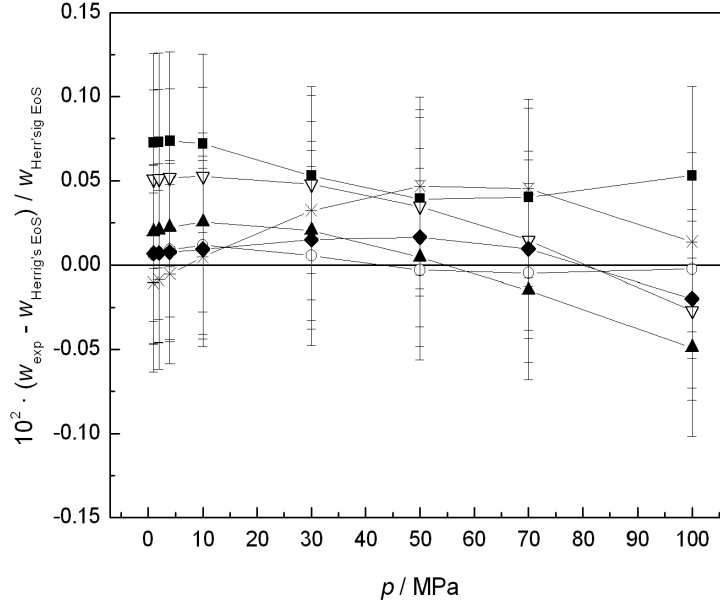

Figure 9: Relative deviation of experimental speed of sound results from Herrig's EoS limited in pressure to 100 MPa. Symbols belong to (■) 297.97 K; (○) 283.15 K; (▲) 303.15 K; (▽) 323.15 K; (◆) 343.15 K; (\*) 363.15 K.

by predictions not validated by experimental results. Comparing the plots in figure 7 and 8, it is apparent that the most recent equation[1] performs significantly better than the previous one. For example, the maximum relative deviations decrease from 1 % to 0.1 % for pressure up to 100 MPa. Furthermore, as reported in figure 9, when pressures below 100 MPa are considered, deviations from the equation of state[1] are well within 0.07 %.

For pressure below 20 MPa, very accurate speed of sound measurements are available from Wegge *et al.* [5] with a declared uncertainty of 0.015 %. That experiment was carried out using a measurement cell with different lengths of the spacers, a different carrier frequency and a different piezoelectric source, both in terms of materials and dimensions, so that obtained results can be considered as independent. In Wegge *et al.*[5], nominal spacers lengths were (20 and 30) mm

and a 15 mm diameter X-cut quartz crystal was used as an ultrasonic source when excited by 30-cycles sinusoidal burst with a carrier frequency of 8 MHz. Quartz crystals can operate up to temperature higher than those of ceramic piezoelectric disks adopted in this work. Anyway, considering the maximum temperature here investigated, both the materials are equivalent. Differences are more evident considering the band-width and the sensitivity of the two different sources. Quartz crystals have a lower sensitivity, so they need to be excited by a higher number of cycles (30 in that case), before reaching their maximum oscillation amplitude. Here adopted wide-band encapsulated ceramic disk can reach maximum amplitude oscillation after just three cycles. The quartz crystal intrinsic narrow band has the side effect of generating much more oscillations with respect to those used to excite the source. For wide-band sources, working out of their resonant frequency, only a couple of extra cycles are recorded by the digital oscilloscope. Considering the frame of the measurements reported in this work, both the sources perform at the same level since in both cases the time-of-flight is measured with a relative uncertainty below 20 part per million. The better accuracy obtained by Wegge *et al.* comes from a better measurement of the temperature and the pressure, since they have used a Standard Platinum Resistance Thermometers and a pressure transducer with a better accuracy.

From figure 10, which illustrates a comparison between the results obtained here and those of Wegge *et al.*, it is possible to observe a significant negative relative deviation.

A possible explanation for the systematic deviation of these two measurements sets can possibly ascribed to a different purity of the sample because the heavy water used in Wegge *et al.* was pure at 99.995 % D atoms, while the purity of the sample used in this work was only 99.85 % D atoms. Despite this significant purity difference, speed of sound results of this work are still consistent with those of Wegge *et al.*, considering their combined uncertainties. The only isotherm showing a significant deviation is that at the lowest temperature where, probably, the effect of the contamination is enhanced by proximity to the freezing curve.

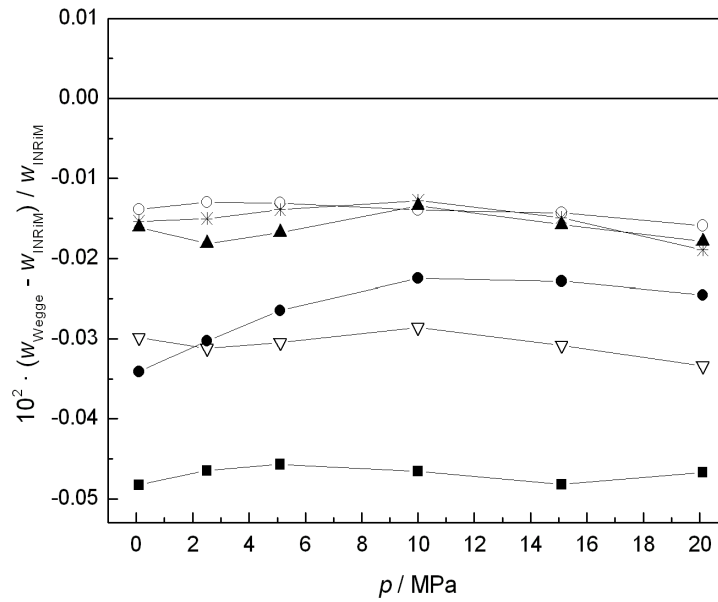

Figure 10: Comparison with the experimental speed of sound results of Wegge et al. [5] as a function of the pressure. Results are shown by isotherms: (■) 278.21 K; (○) 283.20 K; (▲) 293.20 K; (▽) 310.20 K; (●) 333.20 K; (\*) 353.20 K.



#### 4. Conclusion

In this work, we report more than seventy experimental speed of sound measurements in heavy water (deuterium oxide,  $D_2O$ ; purity: 99.85 %) on six isotherms between (276.97 and 363.15) K and, for the first time, for pressure up to 210 MPa. The results have been obtained using the double *pulse-echo* technique and their estimated expanded relative combined uncertainty ( $k = 2$ ) is, over the whole temperature range, in the order of 0.05 % for pressures above 10 MPa and of 0.03 % for pressures below 10 MPa. The obtained speed of sound values have been compared with the predictions of the reference equation for heavy water (IAPS84 Formulation) by Hill *et al.* (1982) and with those calculated from the newly developed EoS for heavy water by Herrig *et al.* (2018), with resulting relative deviations that are always less than the combined uncertainties. The speed of sound results have been compared with the most recent results of Wegge *et al.* finding a remarkable agreement within the declared uncertainty (better than 0.05 %).

Future work is planned to extend speed of sound measurements in deuterium oxide at temperatures lower than the triple-point and for pressure up to 300 MPa. When available, these results will be useful to update the recent dedicated EoS developed by Herrig *et al.* (2018).

## Acknowledgements

The authors do thank Stefan Herrig for kindly sharing data and information about his work before publication. Furthermore, the authors would like to thank the International Association for Properties of Water and Steam for the collaboration and for giving suggestions and ideas for this and future works.

- [1] S. Herrig, M. Thol, A. H. Harvey, E. W. Lemmon, “A Reference Equation of State for Heavy Water”, *Journal of Physical and Chemical Reference Data* 47(4), 043102 (2018).
- [2] W. D. Wilson, “Speed of sound in heavy water as a function of temperature and pressure”, *The Journal of Acoustical Society of America* 33, 314 (1961).
- [3] C. T. Chen, F. Millero, “Speed of sound in deuterium oxide relative to normal water as a function of temperature and pressure”, *The Journal of Acoustical Society of America* 62, 553 (1977).
- [4] A. A. Aleksandrov, D. K. Larkin, “Experimental speed of sound in heavy water in the wide temperature and pressure ranges”, *Teploenergetika* 24(1) pp 73-75 (1977).
- [5] R. Wegge, M. Richter, R. Span, “Speed of sound measurements in deuterium oxide ( $D_2O$ ) over the temperature range from (278.2 to 353.2) K at pressures up to 20 MPa”, *Fluid Phase Equilibria*, 418, 175-180 (2016).
- [6] P.G. Hill, R.D. Chris MacMillan, V. Lee, “A Fundamental Equation of State for Heavy Water”, *Journal of Physical and Chemical Reference Data* 11(1), 1-14 (1982).
- [7] G. Benedetto, R.M. Gavioso, P.A. Giuliano Albo, S. Lago, D. Madonna Ripa, R. Spagnolo, “Speed of sound in pure water at temperature between 274 and 394 K and pressures up to 90 MPa”, *International Journal of Thermophysics* 26, 1667 (2005).

- [8] W. Wagner, A. Pruß, “The IAPWS formulation 1995 for thermodynamic properties of ordinary water substance for general and scientific use”, *Journal of Chemical Physics and Reference Data* 31, 387-535 (2002).
- [9] S. Lago, P. A. Giuliano Albo, D. Madonna Ripa, “Speed of sound measurements in n-Nonane at temperatures between 293.15 and 392.15 K and pressures up to 100 MPa”, *International Journal of Thermophysics* 27(4), 1083 (2006).
- [10] S. Lago, P. A. Giuliano Albo, J. S. Brown, “Compressed liquid speed of sound measurements of cis-1,3,3,3-tetrafluoroprop-1-ene (R1234ze(Z)), *International Journal of Refrigeration* 65, 55 (2006).