

Feasibility Study of an Innovative Urban Electric-Hybrid Microcar

Original

Feasibility Study of an Innovative Urban Electric-Hybrid Microcar / Ferraris, Alessandro; Micca, Federico; Messina, Alessandro; Airale, Andrea Giancarlo; Carello, Massimiliana. - In: INTERNATIONAL JOURNAL OF AUTOMOTIVE TECHNOLOGY. - ISSN 1229-9138. - ELETTRONICO. - 20:2(2019), pp. 237-246. [10.1007/s12239-019-0023-x]

Availability:

This version is available at: 11583/2731902 since: 2019-05-01T10:38:39Z

Publisher:

Korean Society of Automotive Engineers

Published

DOI:10.1007/s12239-019-0023-x

Terms of use:

This article is made available under terms and conditions as specified in the corresponding bibliographic description in the repository

Publisher copyright

Springer postprint/Author's Accepted Manuscript

This version of the article has been accepted for publication, after peer review (when applicable) and is subject to Springer Nature's AM terms of use, but is not the Version of Record and does not reflect post-acceptance improvements, or any corrections. The Version of Record is available online at: <http://dx.doi.org/10.1007/s12239-019-0023-x>

(Article begins on next page)

FEASIBILITY STUDY OF AN INNOVATIVE URBAN ELECTRIC-HYBRID MICROCAR

Alessandro Ferraris¹⁾, Federico Micca²⁾ Alessandro Messina¹⁾, Andrea Giancarlo Airale¹⁾ and Massimiliana Carello^{1)*}

¹⁾ Mechanical and Aerospace Engineering Department , Politecnico di Torino, c.so Duca degli Abruzzi 24, Turin 10129, Italy

²⁾BeonD, C.so Castelfidardo 30/a, Turin 10129, Italy

(Received date ; Revised date ; Accepted date) * Please leave blank

ABSTRACT– This paper presents the feasibility study of a new platform for electric-hybrid quadricycles, developed by addressing important concepts like passive safety and comfort, which often represent a shortcoming in this vehicle category. Starting from packaging of energy storage system and macroscopic subsystems as the main technological constraint, the study has been entirely developed in a virtual environment, with finite element verifications on preliminary models, and a subsequent cooperation phase between computer aided design and finite element analysis softwares, with a guideline for the main tests being that each could feasibly be carried out on a complete vehicle model in order to validate the original assumptions. The resulting design, with a body curb mass of less than 100 kg, was capable of integrating optimal static stiffness characteristics and crash performance, together with improved vehicle dynamics thanks to an innovative suspension archetype.

KEY WORDS : Hybrid vehicle, finite element analysis, urban mobility, passive safety

NOMENCLATURE

EV: electric vehicle
PHEV: plug-in hybrid electric vehicle
CAD: computer aided design
FEA: finite element analysis
NEDC: new European driving cycle
NYCC: New York city cycle
EM: electric motor
ICE: internal combustion engine
IPMSM: internal permanent magnet synchronous machines
SPM: surface-mounted permanent magnet
ABS: anti-blocking system
OPF: one pedal feeling
CFRP: carbon fiber reinforced plastic
MGU: motor generation unit
BMS: battery management system

* Corresponding author. e-mail:
massimiliana.carello@polito.it

1. INTRODUCTION

It is evident, from a study carried out by Frost & Sullivan (Frost & Sullivan, 2011), that the densification of urban settlements is the most critical aspect in world population increase, especially for what concerns so called “megacities”. It is expected that, by 2025, cities like London and Seoul will lead the trend of population density, with 8749 people/km² and 8008 people/km² respectively. As a consequence, the growth forecasts of the number of private means of transport per resident would assume particular importance if related to CO₂ emissions and toxic exhausts deriving from human activities.

These alarming trends, in the recent years, have been pushing researchers towards the development of vehicles particularly suited for urban environment, by focusing on lightweight design, driving range, safety, comfort, and ease of use (Tanik and Parlaktas, 2015, Moriarty and Honnery, 2005). To this purpose, transport electrification represents one of the most interesting

long term solutions, also in regards to the tighter fuel economy targets. As a matter of fact, some beneficial trends are confirming the interest of car manufacturers in pushing towards green mobility, among them, the rapid decrease in battery prices for Electric Vehicles (EVs) and Plug-in Hybrid Electric Vehicles (PHEVs), expected to reach \$100/kWh by 2030 (\$1000/kWh in 2010) (McKinsey, 2017). Finally, both autonomous driving and cars' interconnectivity mega-trends could represent strong partners to the growth of the electric and hybrid vehicles market. On the basis of this data, today's car conception becomes totally out of date: no more general purpose vehicle but designed to fit specific urban mission as for example the daily journey "home-work". The complex context highlights the lack of basic solutions for urban mobility, with vehicles conceived to face specific situations linked to their purpose, with minimal equipment consisting of few strategically chosen accessories.

To cope with an increasing number of requirements, heavy quadricycles, L7e category, as described in the European Directive (Regulation EU 168/2013, 2013), could represent a compromise solution for personal mobility in urban areas for their compactness, lightness, relative simplicity, easiness to drive and the employment of low power engines. Finally, the opportunity to implement electric drives in this vehicle category could potentially extend the horizons of emissions cutting.

An important step forward in this field was taken in 2012 by the Team H₂politO of the Politecnico di Torino, whose students, thanks to prior experience with the development of fuel cell vehicle prototypes (Airale *et al.*, 2011; Carello *et al.*, 2014a; Carello *et al.*, 2015a; Filippo *et al.*, 2013), succeeded in designing and building a road legal electric hybrid heavy quadricycle prototype, named XAM2.0 (Carello *et al.*, 2014b; Carello *et al.*, 2014c; Carello *et al.*, 2014d; Ferraris *et al.*, 2017; Carello *et al.* 2015b; Carello *et al.*, 2012; Carello *et al.* 2014e), able to participate in the Brighton-London Future Car Challenge 2012 and win the "Best Range Extender Prototype" award. However, XAM2.0 was not conceived with crashworthiness targets, and its ride dynamics were developed as a race car, rather than taking into account passengers' comfort.

Therefore, the main scope of this study was the creation of a new urban vehicle platform, applied to the smallest four-wheeled vehicle category (L7e) able to address the basic needs of a present day passenger car, with primary interest in energetic balance, safety and handling, and introducing an innovative suspension system by adopting transverse leaf spring in composite material (Carello *et al.*, 2017; Xu *et al.*, 2017, Fasana *et al.*, 2016).

The second reason to design an L7e (heavy quadricycle) was the will of bringing innovation to a

market segment which is unfortunately dominated by lack of investment, to which car makers show an extremely low level of interest, even if the norms do not impart as strict restrictions as for M1 category (passenger cars) (Commission Directive 2001/116/EC, 2001). In particular, in the safety field, no legislations regulate the crash homologation of heavy quadricycles, and only in 2014 Euro NCAP introduced the first protocol for L7e, limited to front and side crash, at 50 km/h on a deformable barrier (Euro NCAP, 2014a; Euro NCAP, 2014b), with ratings based just on adult safety; the results obtained by the submission of some models to those tests, show that a large improvement margin exists, especially in the development of high energy absorbing structures (Boria *et al.*, 2015).

2. TARGETS SETTING AND DESIGN PROCESS DEFINITION

The first step of the project was to perform an effective analysis of the objectives, which were consequently subdivided into general requirements (to describe the global aspects of the final product) and specific targets (to give indications on features related to the development in each project area).

The activity plan is shown in Figure 1. The starting point was target setting, secondly, a packaging study was performed in order to define the encumbrance of each of the sub-systems; after that, the first body concept was designed using Computer Aided Design (CAD) software in order to make sure that the passengers' ergonomics were respected; finally, structural requirements were verified by means of Finite Element Analysis (FEA), through a set of virtual tests aimed at assessing the body's static, crash and vibration performance.

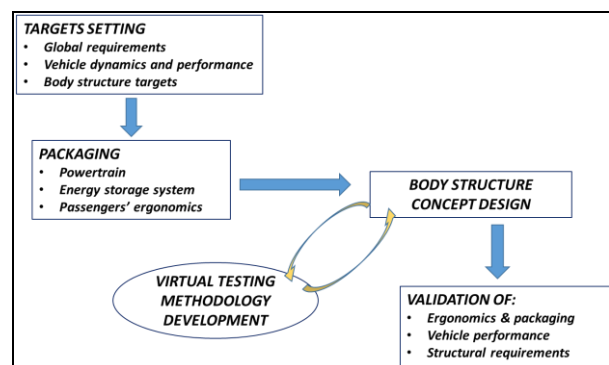

Figure 1. Design and validation process

2.1. Global Vehicle Requirements

As it is recapped in Table 1, the objective was to develop a multi-purpose platform, to which either a full electric or a series hybrid range-extended archetype could be implemented; this would have given the possibility of designing a configurable vehicle, according to the specific mission to which the quadricycle was targeted. Overall dimensions were decided from the analysis of potential competitors like Smart Fortwo (in M1 vehicle category), while mass targets are imposed by European Regulations.

Table 1. General vehicle requirements

Vehicle class	L7e (heavy quadricycle)
Powertrain architecture	Plug-in full electric or series hybrid-electric (configurable)
Energy supply	Electrical (for full electric architecture), or both electrical and fossil fuel (for hybrid powertrain)
Drive	Electric motor, front wheel drive
Number of passengers	Two-seater, three doors
Ergonomics	H-Point height: 570 – 600 mm
Luggage compartment	> 150 L
Total curb mass	~ 500 kg (including battery pack)
Total length	~ 3 m
Total height	< 1.5 m
Wheelbase	~ 2 m
Track	~ 1.3 m
Steering diameter between walls	8 m
Ground clearance in full loaded condition	> 150 mm
Tires	145/65 R15

2.2. Vehicle Performance and Powertrain architecture

After global targets, the analysis of the energetic balance was performed. To do this, some data related to vehicle performance in longitudinal dynamics had to be defined as in Table 2, taking into account the limitations prescribed by the European regulations.

In order to evaluate the overall consumptions, and to obtain the 80 km range in full electric mode, which was assumed as the most critical vehicle configuration, a *Simulink* model of the powertrain was prepared (Chindamo *et al.*, 2013), for two representative driving cycles employed by M1 vehicles: the New European Driving Cycle (E/ECE, 2013)), which is going to be retired, but is still in use for homologation in the European Community, and the New York City Cycle (Code of Federal Regulations, 2003), which is more critical than the first one, especially in urban environment. As a result of the analysis, taking into

account that the nominal voltage of the battery pack should be limited to 48 V by regulation (ISO, 2012), the quadricycle should be equipped with a 15 kW nominal power electric motor, and a battery pack capable of providing around 9 kWh total energy. The voltage range of the electric motor (EM) has been derived from the battery pack maximum voltage, equals to 60V. An Internal Permanent Magnet Synchronous Machines (IPMSM) motor has been chosen for its higher torque, with respect to an SPM (Surface-mounted Permanent Magnet) machine. Figure 2 shows the vehicle powertrain architecture adopted in the hybrid electric configuration.

Table 2. Performance targets

Maximum speed	90 km/h (limited by regulation)
Nominal power	15 kW (limited by regulation)
Longitudinal acceleration	0 – 50 km/h < 7 s
Maximum allowable slope	25 %
Full electric range with one charge	80 km
Range extended in km	> 300 km

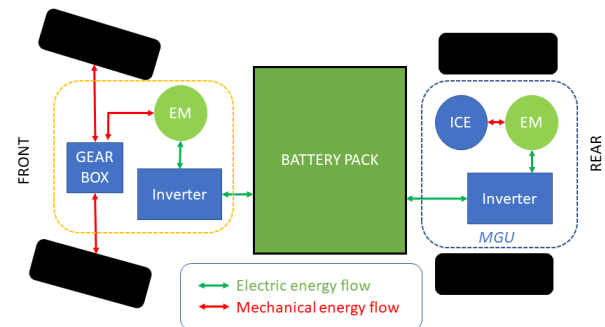

Figure 2. Powertrain architecture and energy flows in range extended configuration

The driving range represents a key factor and a target of 300 km could be the best compromise for an urban city vehicle. In order to maximize the driving range of the EV configuration, particular attention must be paid on regenerative braking. Moreover particular attention has been paid in the identifications of subsystem dimensioning and control logic definition of the whole powertrain (Cubito *et al.*, 2017). A first implementation of the cooperation between regenerative braking and ABS was performed to achieve the goals reported in Table 2. Then, it has been studied a system in which ABS is coupled with One Pedal Feeling (OPF) limited by constant torque of the electric motor as shown in Figure 3 .

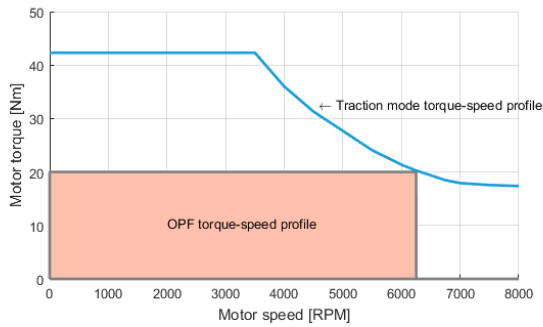

Figure 3. EM curve for traction and regenerative braking with OPF

In so doing, the braking repartition must change when the ABS works. Moreover, the control logic for energy harvesting is based on speed synchronization. Traction mode is switched on when the speed sensor in motor detects the motor speed is less than the demanded speed. When motor speed exceed the target speed, the inverter start energy recovery mode and turns the traction motor into a generator, which recovers the kinematic energy to charge the battery pack. Control logic for safety reason considering the intereaction between ABS and regenerative braking has been implemented with a bollen based function (Ferraris *et al.*, 2018).

2.3. Vehicle Dynamics and Suspensions Architecture

The weight reduction of un-sprung elements of a car represents one of the most difficult and competitive areas for lightweight design, and the use of composite materials can be successfully spread also to this field (Richard, 2003).

Starting from a previous study (Carello *et al.*, 2017; Xu *et al.*, 2017; Fasana *et al.*, 2016), it was decided to adopt a transversal leaf spring suspension made in Carbon Fibre Reinforced Plastic (CFRP), as in Figure 4, coupled with a McPherson architecture, both for front and rear axles, with the objective of reducing both mass and the number of components of the un-sprung masses. In the proposed configuration, in order to provide function integration, the leaf spring was not only designed as a spring element, but it also accomplished to the tasks of anti-roll bar and suspension arm. There were three main reasons to adopt a McPherson architecture:

1. The possibility to shrink the overall transversal dimensions, and to clear space for luggage as well as powertrain.
2. The reduction in structural complexity.
3. The cost effectiveness, because the same components could be used, both in the front and in

the rear end, and overall vehicle cost would be reduced.



Figure 4. Manufactured CFRP transverse leaf spring

To obtain the optimal dynamic behaviour, the most frequently occurring situation was considered for an urban vehicle, in particular, when there is only one passenger: the driver itself. The total mass for this configuration was computed to be around 610 kg, including the curb mass, liquids, an adult driver and some luggage. The starting point for the determination of the suspensions' hardpoints in *MSC Adams Car* was therefore a mass distribution of 55% front and 45% rear, while the stiffness target for the leaf spring could be varied in order to obtain different values of lateral acceleration. The spring was designed to have a linear characteristic during both parallel wheel travel and opposite wheel travel in the range ± 70 mm, together with a first resonance frequency of the suspended mass around 1.5 Hz.

Moreover, two preliminary simulation has been done to evaluate the maximum lateral acceleration and the overall handling of the car: step steer and skid-pad tests. The simulation of step steer has been performed at 90 km/h, and steering wheel has been turned 90° in 1 second.

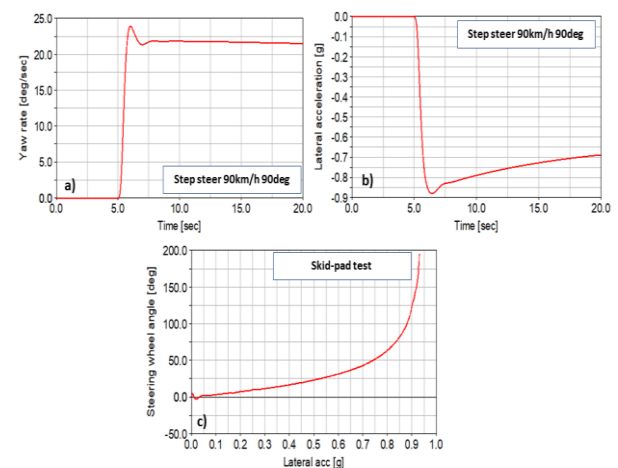

Figure 5. Step steer results (a,b) and skid pad test (c) The result in Figure 5 (a) shows a small over-shoot for yaw rate and stabilized in a very short time, the vehicle keeps steering at with deg/s. The maximum lateral

acceleration happens at the over-shoot, then gradually reduced to its quasi steady-state value as shown in Figure 5 (b). The skid pad simulation has been performed to reach its maximum lateral acceleration about 0.94g, which is very good for a two seats small vehicle. The result in Figure 5 (c) also shows a very stable under-steering behavior to guarantee the driving safety.

2.4. Body Structure

In this analysis, the body structure was treated as one of the vehicles systems, with the functions of:

1. Carrying and connecting all other vehicle subsystems.
2. Providing the functional space to host the passengers without limiting ergonomics.
3. Providing a solid structure to improve dynamic behaviour during manoeuvres and obstacles overcome.
4. Guaranteeing passengers' safety in case of collision.
5. Providing insulation from the external environment (Morello, 2011a).

According to these needs, it was chosen to adopt a space frame structure plus outer aesthetic body, in order to keep the design as simple as possible, and mass, stiffness, and crash performance were identified as the most relevant parameters to work on.

As regards the mass, European Legislations for L7e impose an upper limit to curb mass of 450 kg, excluding the battery pack, if the car is electrically propelled. For the project under study, the total target mass, including also the battery pack, was initially set to 500 kg; in this way, when considering an approximate battery pack mass of 100 – 150 kg, according to the battery cell type, the resulting curb mass would be around 350 – 400 kg, quite far below the limit.

To reach the mass target, it resulted that the body structure had to weigh less than 100 kg, therefore it was decided to adopt an aluminium space-frame. Aluminium, with its good stiffness to mass ratio, represented the best choice for making up the main structure of the car (Moon-Kyun et al., 2007); moreover, the possibility of employing commercially available extruded bars was regarded as a key factor for cost reduction during a future possible prototype building phase.

Body stiffness requirements hardly correspond with lightweight design; anyway, the adoption of a space-frame in this case was helpful because it allowed the identification of the strongest structure geometry even at the initial concept stages. Therefore, taking into account the dimensions of the vehicle and the mass requirements, the values of 5000 – 8000 Nm/° and 5000 – 8000 N/mm were assumed as a hypothetical target for torsional stiffness and bending stiffness respectively. Body stiffness is also related to its vibrational behaviour,

which in turn determines tactile comfort of the occupants, through a solid feeling vehicle; to be sure that no couplings occurred between any of the body vibration modes and the unsuspended masses' first resonance frequency (defined to be around 15 Hz), the first natural frequency of the chassis should stay around 35 Hz (Sheng, 2012).

One of the reasons why modern heavy quadricycles are not built starting from a stiff frame is the lack of legislation in the homologation crash test field, moreover, the use of low quality steels has no benefit to the energy absorption capacity, and may even worsen the structure's behaviour during collision. In the present work, safety was one of the main targets. The resulting design should then provide functional differentiation, with the design of a stiff cockpit, able to maintain its original shape without large deformations, and a collapsible front end, with high energy absorption components (Piano, 2009).

3. VEHICLE PACKAGING AND ERGONOMICS

At the beginning of the design, packaging was identified as the most relevant aspect, because it allowed the adoption of more suitable solutions for mass and volume reduction, and, of course, it was essential to obtain the best ergonomics for passengers. A 50% front and 50% rear curb mass distribution was assumed as a good starting point for a front wheel drive vehicle, considering that the introduction of one passenger and some luggage would have shifted the mass distribution towards 55% - 45% (as determined in preliminary vehicle dynamics studies). The platform was then designed with the electric motor located in the front, the Motor Generation Unit (MGU, in the range extended configuration) on the rear axle together with a 5 L fuel tank, and the battery pack integrated in the platform (Hodkinson *et al.*, 2001), as shown in Figure 6.

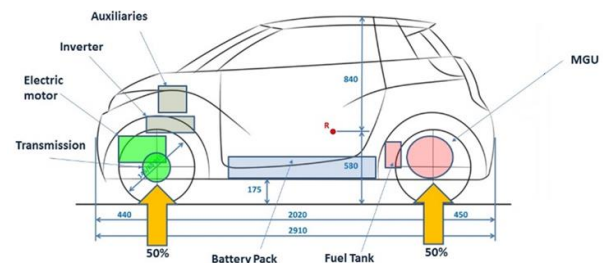

Figure 6. Powertrain and energy storage system layout, initial concept

In this way, the battery pack layout assumed a predominant role in determining the mass distribution along the wheelbase. Benefits from this configuration were also: the lowering of the center of mass for a

reduction of vehicle roll during cornering, and the possibility of designing a structural pack, able to protect batteries during crash and to increase the overall frame's stiffness.

To accomplish the target of 9 kWh of energy stored, Li-ion technology employed in commercial battery cells (with capacity of 20 Ah and nominal voltage of 3.3 V), was used, with a preference for pouch geometry, rather than cylindrical, in order to improve space savings; this resulted in a layout featuring 23 sub-modules, with 6 cells each, for a total of 138 cells, plus room for power cables, Battery Management System (BMS), cooling ducts and possible internal structural reinforcements, as shown in Figure 7. Of course, the amount of total energy can be reduced by reducing the number of cells. In this way it would be possible to adapt the maximum driving range according to the specific needs of the customer, with benefits for both the total mass and energy consumptions.

The adoption of this particular battery pack layout had a ripple effect on both passengers' ergonomics and main subsystems setup. Despite the floor of the cockpit being raised because of the battery pack's height, this was not considered a drawback, as it might give to the driver a more comfortable seating position, which is quite often preferred in a urban vehicle.

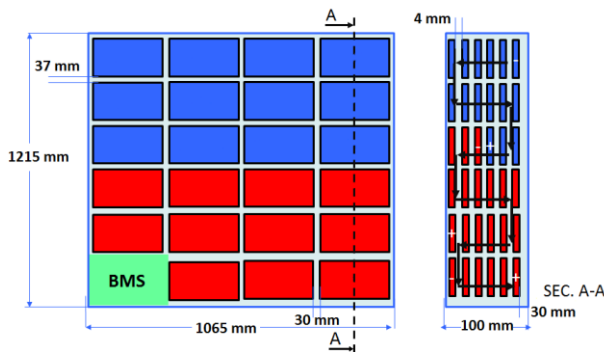

Figure 7. Battery pack's internal layout. BMS: Battery Management System

After the battery pack definition, to start with the ergonomics of passengers, a 2D model was used, based on the 2D manikin model used in SAE J826 (SAE, 1995), for the 95th percentile man, with H point height between 570 mm and 600 mm from ground, as imposed during target setting. The head contours, to correctly determine passengers' head position, were defined by following SAE J1052 (SAE, 2002). The resulting angles between different body segments, as shown in Figure 8, represent a suitable solution to reduce driver fatigue, as they provide a reclined position, good to reduce the load on the backbone (Morello, 2011b).

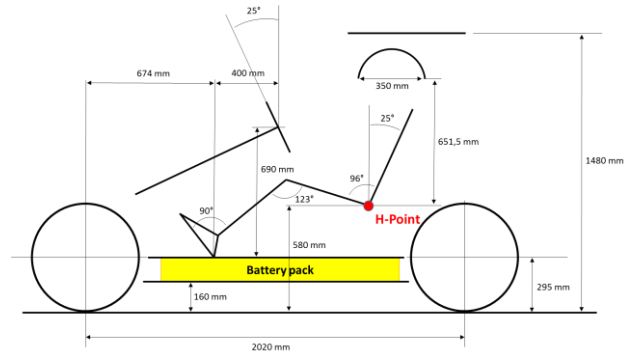

Figure 8. 2D passengers' ergonomics layout

4. BODY STRUCTURE DESIGN AND TESTING METHODOLOGY

Packaging of subsystems is unavoidably related to the development of a suitable structure for the vehicle. To obtain a stiff and crash resistant cockpit, therefore, the necessity of a conceptual design stage was clear, in which the global chassis geometry would have been considered as a trade-off (Kim *et al.*, 2005), before starting with more extensive and detailed design and validation phases.

4.1. Concept Design

In this first step, a complex CAD model was still not defined; on the contrary, to help with the development of the best compromise for the body, a preliminary study with simplified FEA calculations was carried out using *Hyperworks* suite. To this purpose, the use of mono-dimensional beam elements to model space frame structures, even for the entire vehicle body, is very much a usual practice in the automotive field (Mundo *et al.*, 2010). As a matter of fact, beam elements have very low computational times and the approximation of test results is enough to make simple considerations on feasibility.

To validate the mono-dimensional models in the linear static field, using *Optistruct* solver, three basic evaluations were taken into account: torsional stiffness test (K_t), bending stiffness test (K_f), and modal analysis, which were assumed to be enough to assess the merit of the space frame in the concept phase. For the torsional stiffness test, as shown in Figure 9 (a), the chassis was constrained at the wheel centers in order to obtain an isostatic condition, while the front wheel was loaded with a 1000 N force. The bending stiffness was evaluated, as in Figure 9 (b), by applying 500 N vertical force on each rocker, in line with the center of mass of the structure, and by constraining the frame in such a way that it could rotate about the wheel centers and translate just in x direction. Finally, modal analysis was

carried out in the free-free condition, without constraining the structure.

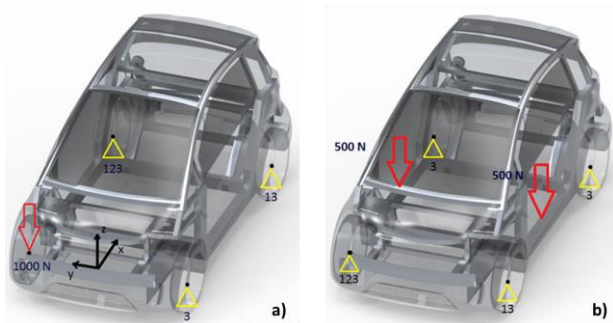

Figure 9. Torsional (a) and bending (b) stiffness evaluation.

The resulting chassis structure was able to satisfy the original stiffness requirements, with $K_t = 5537 \text{ Nm}^\circ$, and $K_f = 5831 \text{ N/mm}$, weighing only 56.2 kg. The model featured a central square basis frame, plus similar front and rear end structures, as shown in Figure 10. In this way it was possible to provide the function differentiation which is the basis for crashworthiness design: the employment of larger sections for the cockpit, in order to increase its stiffness, and thinner sections for the front and rear ends, to enhance their collapsibility. For what concerns loads distribution to the cockpit, the introduction of a stiff battery pack structure would play the major role, as it would fill in the void in the floor. Finally, with a total of three loading lines along the traveling direction, it is possible to distribute in an even way the loads to the frame, preventing the onset of dangerous pitching moments.

A mix between conventional square and rectangular bars was chosen to make up the space frame, plus some special sections specifically designed for the roof rail and the cowl top, in order to provide a high stiffness to mass ratio for the upper body part.

After the definition of the structure, it was possible to validate vehicle dynamics assumptions, in particular, hardpoints' locations were modified in *MSC Adams Car* to satisfy both dynamic performance and structural similarity between front and rear ends.

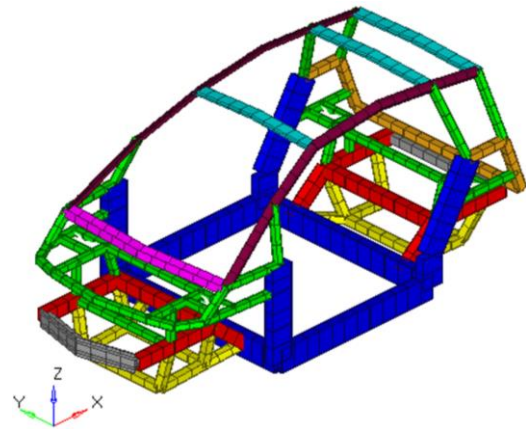

Figure 10. Simplified space frame model

4.2. Concept Refinement

Once the design guidelines had been fixed, it was decided to translate the original concept into the first CAD model of the body structure, using *Autodesk Inventor 2015*; by doing so, it was possible to validate packaging in a more realistic way.

Other reasons why it was absolutely necessary to introduce a first full vehicle modelling phase inside the feasibility study were:

1. The possibility of introducing a simple structure for the battery pack, to be added to the body in order to evaluate its influence on both static and dynamic performance.
2. The possibility of checking, through finite element analysis, if the results related to stiffness and body's natural frequencies were within the ranges proposed at the beginning.
3. The possibility of implementing a first virtual front crash test of the body in order to catch its global behaviour.

To pursue modularity and compactness, the body was therefore conceived to be composed by three distinct sub-assemblies, as shown in Figure 11 (a): the main structure plus two detachable ancillary frames, devoted to carry respectively:

1. In the front: suspension, wheel assembly, the electric motor and the steering rack.
2. In the rear: suspension and MGU.

A simple battery pack structure made up of internal longitudinally and transversally placed rails was introduced, as seen in Figure 11 (b), in order to provide continuity from the front load lines and the pavement, and with the aim of checking if the hypothesis for the cells disposition was effective

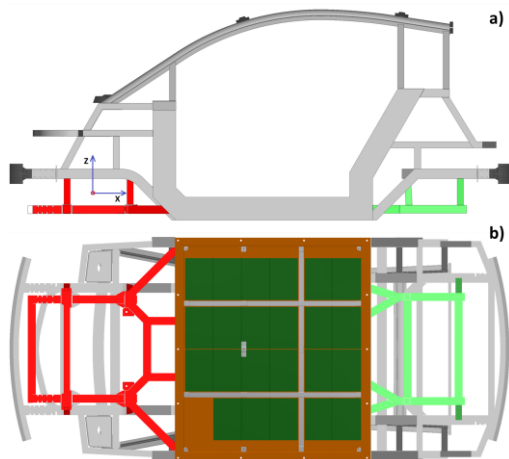

Figure 11. Full vehicle structure model in side view (a), and bottom view (b)

4.3. Vehicle Validation

In order to validate the original assumptions made on packaging stiffness and safety, it was decided to adopt the testing flowchart of Figure 12. The ergonomics were first reviewed, and then the main tests to assess the structural performance were carried out.



Figure 12. Iterative validation checks

To check if the initial assumptions on passengers positioning were followed, during this refinement phase, it was decided to adopt a 3D dummy (95th percentile man), instead of employing the 2D manikin model. Dimensional differences between the 2D and the 3D dummy model led to slight corrections in the seating position, as shown in Figure 13.

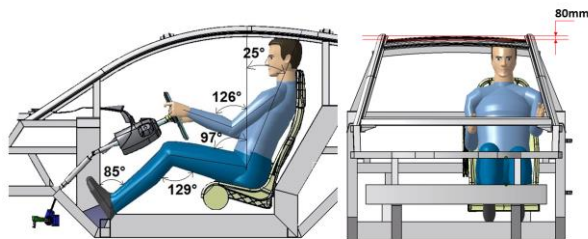

Figure 13. 3D dummy ergonomics

After which, torsional stiffness and modal analysis simulations had to be repeated by preparing a full FEA model, in order to record the changes from the preliminary model, and to check if the targets were met.

By analysing the results shown in Table 3, it is possible to see that the mono-dimensional model overestimated both stiffness and vibrational behaviour. This is the main drawback when using beam elements in FEA modelling, as it is not possible to reproduce the real compliance of the connecting nodes. Therefore the complete model had good torsional stiffness, while bending stiffness was below the imposed target. Despite these results, the introduction of a structural battery pack on the floor had a positive effect in each of the analysed fields; thus, it is possible to say that the battery pack, being a closed structure with huge inertial properties, can essentially determine the stiffness results on the whole body, when designing an electric car.

Table 3. Stiffness and natural frequency comparison

Model	Mass [kg]	K_t [Nm/°]	K_f [N/mm]	f_1 [Hz] (1 st natural frequency)
PRELIMINARY model (Figure 9)	56.2	5537	5831	37.9
COMPLETE MODEL (without battery pack, Figure 10)	74.0	5213	4604	35.0
COMPLETE MODEL (with battery pack, Figure 11)	99.8	8770	6555	46.3

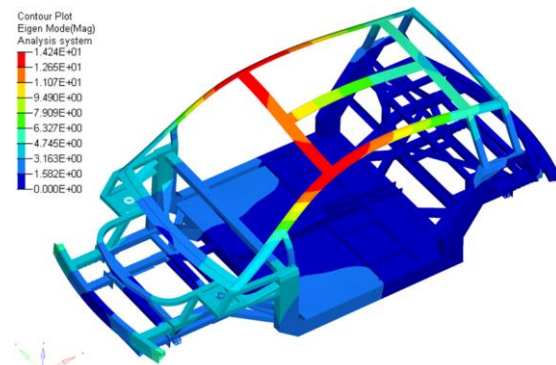

Figure 14. 1st vibration mode shape of the complete body

From the point of view of natural frequencies, the lower bound of 35 Hz imposed at the beginning of the study was always respected. The best results came from the model of the complete body with integrated battery pack structure, in which a 1st frequency of 46.3 Hz was considered to be extremely good in order to avoid dangerous resonances with unsuspended masses; in addition, this first vibration mode of the chassis is a global torsion along the longitudinal X axis, as shown in Figure 14, and not a local panel vibration, which instead

could represent a noise and discomfort source on road driving.

To obtain good results in case of crash, an occupant deceleration in the range 20-30 g should be recorded on the cockpit structure (Piano, 2009); as a matter of fact, this value could be further decreased if the passengers wore safety belts and the car was equipped with air bags, but this would require a full vehicle model with dummies. Therefore, a crash test was simulated with *Radioss*, by using just the space frame model, launched at 50 km/h onto a deformable barrier (Piano, 2009). To make sure that the mass of the impacting object was similar to the mass of the complete vehicle, a total of 400 kg were distributed onto simplified bodies representing the powertrain, the battery pack, and the MGU. The resulting decelerations on the chassis, shown in Figure 15, were filtered using a CFC 60 filter, as recommended SAE practice (SAE, 1995); the peak was recorded around 28 g, fully inside admissible range.

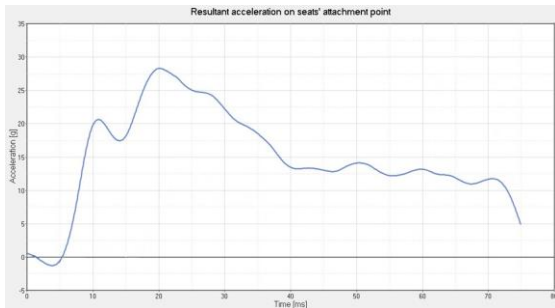

Figure 15. Body structure deceleration in front crash

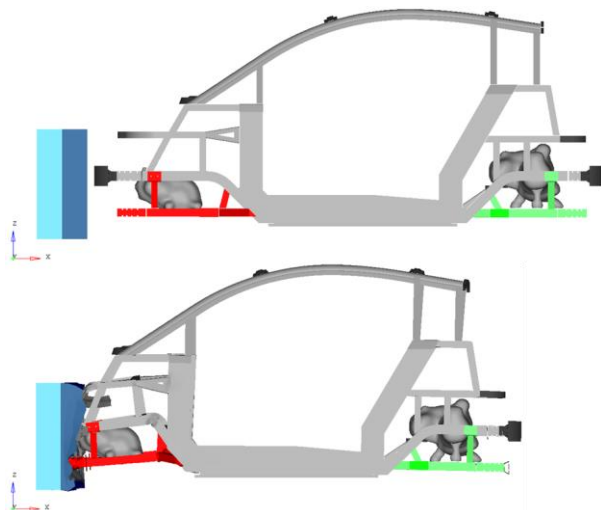

Figure 16. Front crash on deformable barrier, at 50 km/h From a qualitative point of view, it was possible to achieve full cockpit integrity, with deformation limited only to the front end, as shown in Figure 16. This result

was possible thanks to the longitudinal rails, aligned with the centre of mass of the vehicle, in a position in which they could be loaded in full compression, leading them to axial folding rather than bending.

5. CONCLUSIONS

The aim of the paper was to develop a strategy for the feasibility study of an electric-hybrid heavy quadricycle platform, starting from blank sheet. Targets were defined first, focusing the attention on vehicle dynamics, packaging, structural integrity and lightweight. After that, body geometry was chosen according to the results coming from preliminary FEA tests on simplified models. Finally, a first version of the complete CAD model was developed, in order to check passengers' ergonomics in detail and to verify the validity of assumptions made with the preliminary model.

The results show that it was possible to carry out a feasible design for a very small electric vehicle, by employing a new battery pack layout, which became an integrating part of the structure, and the driving element in each of the following design phases. With this platform typology, it would be possible to create a highly adaptable vehicle layout (full electric or series hybrid according to the specific needs) able to provide a comfortable seating position even for 95th percentile man. The use of McPherson architecture, coupled with a carbon fiber transverse leaf spring, could represent an interesting application for this vehicle category, both for its lightness, and for global dynamic performance, with a maximum lateral acceleration, reached in virtual tests, of 0.94g. With a total body mass of 74 kg, stiffness targets were not fully met, especially concerning the bending stiffness. In spite of that, the benefits coming from the adoption of a structural battery pack in the floor were huge, against a total body structure mass increase up to 100 kg. Finally, with a modular design of the front and rear ends, together with a stiff cockpit, it was possible to guarantee less than 28 g deceleration on the structure in case of front crash at 50 km/h.

The results obtained in this study could be considered as a good starting point for a future chassis development phase, focused on a more detailed crash performance assessment, with the optimization of energy absorbing structures, such as crash box and bumper, and with further full vehicle assessments, including all the missing components, such as suspensions and the external body, in the model. Side crash tests and a pole test simulations (which is not yet prescribed by legislation) could be carried out, in order to develop an improved version of the battery pack's structure. From the point of view of vibration studies, a more complete assessment could be carried out, with focus on low frequency optimization, especially on the dashboard cross beam, and dynamic stiffness increase in

suspensions' attachment points, in order to evaluate the response in the frequency range covering the spectrum of most of road profiles (50 to 100 Hz).

Furthermore, once the first prototype will be manufactured, real tests on vehicle dynamics and consumption will be conducted to make numerical correlation and validate the methodology described.

ACKNOWLEDGEMENT– The authors would like to thank the staff of Innovative Electric Hybrid Vehicle research group DIMEAS - Politecnico di Torino, Altair Engineering Italy and MSC Software for providing tools and methodologies for the realization of this study.

REFERENCES

- Airale, A.G., Carello, M. and Scattina, A. (2011). Carbon fiber monocoque for a hydrogen prototype for low consumption challenge. *Mat.-wiss. u. Werkstofftech* **42**, **5**, 386 – 392.
- Boria, S., Maccagnani, S., Giambò, R. and Giannoni, F. (2015). Crashworthiness and lightweight design of an innovative microcar. *Int. J. Automotive Composites* **1**, **4**, 313–332.
- Carello, M., Filippo, N. and D'Ippolito, R. (2012). Performance Optimization for the XAM Hybrid Electric Vehicle Prototype. *SAE Paper No. 2012-01-0773*.
- Carello M., Airale A.G. and Messana A. (2014a). IDRApegasus: a carbon fiber monocoque vehicle prototype. *Mat.-wiss. u. Werkstofftech* **45**, **5**, 397–405.
- Carello, M., Ferraris, A., Airale A.G. and Fuentes, F. (2014b). City Vehicle XAM 2.0: Design and Optimization of its Plug-In E-REV Powertrain. *SAE Paper No. 2014-01-1822*.
- Carello, M., Airale, A.G. and Ferraris, A. (2014c). City Vehicle XAM 2.0: Design and Optimization of the Composite Suspension System. *SAE Paper No. 2014-01-1050*.
- Carello, M. and Airale, A.G. (2014d). Composite Suspension Arm Optimization for the City Vehicle XAM 2.0. In: *Design and Computation of Modern Engineering Materials. Advanced Structured Materials*. Vol 54. Springer. Cham.
- Carello, M., Airale, A.G., Ferraris, A. and Messana, A. (2014e). XAM 2.0: from Student Competition to Professional Challenge. *Computer-Aided Design and Applications* **11**, **1**, S61–S67.
- Carello, M. and Messana, A. (2015a). IDRApegasus: a fuelcell prototype for 3000 km/L. *Computer-Aided Design and Applications* **12**, **1**, 56-66.
- Carello, M., Andrea, S., Airale, A.G. and Ferraris, A. (2015b). Design the City Vehicle XAM using CFD Analysis. *SAE Paper No. 2015-01-1533*.
- Carello, M., Airale, A.G., Ferraris, A., Messana, A. and Sisca, L. (2017). Static Design and Finite Element Analysis of Innovative CFRP Transverse Leaf Spring. *Applied Composite Materials*, 1-16.
- Chindamo, D., Gadola, M. and Romano, M. (2014). Simulation tool for optimization and performance prediction of a generic hybrid electric series powertrain. *Int. J. Automotive Technology* **15**, **1**, 135-144.
- Code of Federal Regulations. Title 40, Protection of Environment, Parts 85-86, Sections 86.115-86.130-86.159-86.160.
- Commission Directive 2001/116/EC (2001) of 20 December 2001 adapting to technical progress Council Directive 70/156/EEC on the approximation of the laws of the Member States relating to the type-approval of motor vehicles and their trailers. E/ECE/324/Rev.2/Add.100/Rev.3 or E/ECE/TRANS/505/Rev.2/Add.100/Rev.3 (2013). Agreement concerning the adoption of uniform technical prescriptions for wheeled vehicles, equipment and parts which can be fitted and/or be used on wheeled vehicles and the conditions for reciprocal recognition of approvals granted on the basis of these prescriptions; Addendum 100: Regulation No. 101.
- Euro NCAP (2014a). L7e frontal impact testing protocol; Version 1.1.
- Euro NCAP (2014b). L7e side impact testing protocol; Version 1.1.
- Fasana, A., Carello, M., Ferraris, A., Airale, A.G. and Bertipolato, D. (2016). NVH Analysis of automotive components: a carbon fiber suspension system case. In: *Advances in Italian mechanism science, Mechanism and machine science*. Vol 47, 345-354. Springer. Cham.
- Ferraris, A., Xu, S., Airale, A.G. and Carello, M. (2017). Design and optimisation of XAM 2.0 plug-in powertrain. *Int. J. Vehicle Performance* **3**, **3**, 273–297.
- Filippo, N., Carello, M., D'Auria, M. and Marcello, A. (2013). Optimization of IDRApegasus: Fuel Cell Hydrogen Vehicle. *SAE Paper No. 2013-01-0964*.
- Frost & Sullivan (2011). Impact of urbanization and development of megacities on personal mobility and vehicle technology planning. Frost & Sullivan.
- Hodkinson, R. and Fenton, J. (2001). *Lightweight Electric/Hybrid Vehicle Design*. Butterworth Heinemann. Oxford.
- ISO 13063:2012(en). Electrically propelled mopeds and motorcycles - Safety specifications.
- Kim, B. J., Kim, M. S. and Heo, S. J. (2005). Aluminum space frame B.I.W. optimization considering multidisciplinary design constraints. *Int. J. Automotive Technology* **6**, **6**, 635–641.
- McKinsey & Company (2017). Electrifying insights: how automakers can drive electrified vehicle sales and profitability. Advanced Industries report.

- Moon-Kyun, S., Jung-Kyu, S., Sang-Jin, H. and Gyung-Jin, P. (2007). Structural analysis and optimization of a low-speed vehicle body. *Proc. IMechE, Part D: Journal of Automobile Engineering* **221**, **3**, 313 – 326.
- Morello, L. (2011a). *The automotive body, Volume I: Components design*. Springer. London.
- Morello, L. (2011b). *The automotive body, Volume II: System design*. Springer. London.
- Moriarty, P., and Honnery, D. (1999). Slower, smaller and lighter urban cars. *Proch IMechE, Part D: Journal of automobile engineering* **213**, **1**, 19-26.
- Mundo, D., Donders, S., Hadjit, R., Stigliano, G., Mas, P. and Van Der Auwaraer, H. (2010). Concept modelling of automotive beams, joints and panels. In: *Proceedings of the 3rd WSEAS Int. Conference on finite differences - finite elements - finite volumes - boundary elements*. Bucharest, Romania.
- Piano, L. (2009). *La sicurezza passiva degli autoveicoli*. Hoepli. Milan.
- Regulation (EU) (2013) No 168/2013 of the European Parliament and of the Council of 15 January 2013 on the approval and market surveillance of two- or three-wheel vehicles and quadricycles.
- Cubito, C., Rolando, L., Ferraris, A., Carello, M. and Millo F. (2017). Design of the control strategy for a range extended hybrid vehicle by means of dynamic programming optimization. *2017 IEEE Intelligent Vehicles Symposium (IV)*, 1234–1241.
- Ferraris, A., Airale, A. G., Messana, A., Xu, S. and Carello, M. (2018). The regenerative braking for a L7e range extender hybrid vehicle. *2018 IEEE International Conference on Environment and Electrical Engineering*, Palermo, Italy, 12-15th June. (manuscript accepted).
- Richard, D. (2003). Automotive suspension systems benefit from composites. *Reinforced Plastics* **47**, 18–21.
- SAE J211/1 (1995). Instrumentation for Impact Test-Part 1-Electronic Instrumentation.
- SAE J1052 (2002). Motor vehicle driver and passenger head position.
- SAE J826 (1995). Devices for Use in Defining and Measuring Vehicle Seating Accomodation.
- Sheng, G. (2012). *Vehicle noise, vibration and sound quality*. SAE International.
- Tanik, E., and Parlaktas, V. (2015). Design of a very light L7E Electric vehicle prototype. *Int. J. Automotive Technology* **16**, **6**, 997-1005.
- Xu, S., Ferraris, A., Airale, A.G. and Carello, M. (2017). Elasto-kinematics design of an innovative composite material suspension system. *Mechanical Sciences* **8**,**1**, 11-22.