

Experimental investigation on a fully thermoplastic composite subjected to repeated impacts

Original

Experimental investigation on a fully thermoplastic composite subjected to repeated impacts / Boria, S; Scattina, A; Belingardi, G. - In: PROCEEDINGS OF THE INSTITUTION OF MECHANICAL ENGINEERS. PART C, JOURNAL OF MECHANICAL ENGINEERING SCIENCE. - ISSN 0954-4062. - ELETTRONICO. - 223:19-20(2019), pp. 6985-7002. [10.1177/0954406219866883]

Availability:

This version is available at: 11583/2746125 since: 2019-09-10T12:38:07Z

Publisher:

SAGE PUBLICATIONS LTD 1 OLIVERS YARD, 55 CITY ROAD, LONDON EC1Y 1SP, ENGLAND

Published

DOI:10.1177/0954406219866883

Terms of use:

This article is made available under terms and conditions as specified in the corresponding bibliographic description in the repository

Publisher copyright

Sage postprint/Author's Accepted Manuscript

Boria, S; Scattina, A; Belingardi, G, Experimental investigation on a fully thermoplastic composite subjected to repeated impacts, accepted for publication in PROCEEDINGS OF THE INSTITUTION OF MECHANICAL ENGINEERS. PART C, JOURNAL OF MECHANICAL ENGINEERING SCIENCE (223 19-20) pp. 6985-7002. © 2019 (Copyright Holder). DOI:10.1177/0954406219866883

(Article begins on next page)

EXPERIMENTAL INVESTIGATION ON A FULLY THERMOPLASTIC COMPOSITE SUBJECTED TO REPEATED IMPACTS

S. Boria¹, A. Scattina², G. Belingardi²

¹School of Science and Technology, University of Camerino
9 Madonna delle Carceri, Camerino, Italy
Email: simonetta.boria@unicam.it

²Department of Mechanical and Aerospace Engineering, Politecnico di Torino
24 Duca degli Abruzzi, Torino, Italy
Email: alessandro.scattina@polito.it, giovanni.belingardi@polito.it

Keywords: Laminated thermoplastic composite, repeated impact tests, damage tolerance

ABSTRACT

In the last years, the spread of composite laminates into the engineering sectors was observed; the main reason lies in higher values of strength/weight and stiffness/weight ratios respect to conventional materials. Firstly, the attention was focused on fibres reinforced with thermosetting matrix. Then, the necessity to move towards low density and recyclable solutions has implied the development of composites made with thermoplastic matrix. Even if the first application of thermoplastic composites can be found into no structural parts, the replacement of metallic structural parts with such material in areas potentially subjected to impact has become worthy of investigation. Depending on the field of application and on the design geometry, in fact, some components can be subjected to repeated impacts at localised sites either during fabrication, activities of routine maintenance or during service conditions. When composite material was adopted, even though the impact damage associated to the single impact event can be slight, the accumulation of the damage over time may seriously weaken the mechanical performance of the structure.

In this overview, the capability of energy absorption of a new composite completely made of thermoplastic material was investigated. This material was able to combine two conflicting requirements: the recyclability and the lightweight. In particular, repeated impacts at low velocity, on self-reinforced laminates made of polypropylene were conducted by experimental drop dart tests. Repeated impacts up to the perforation or up to 40 times were performed. In the analysis three different energy levels and three different values of the laminate thicknesses were considered in order to analyse the damage behaviour under various experimental configurations. A visual observation of the impacted specimens was done, in order to evaluate the damage progression. Moreover, the trend of the peak force interchanged between specimen and dart, the evolution both of the absorbed energy and of the bending stiffness with the impacts number were studied. The results pointed out that the maximum load and the stiffness of the specimens tended to grow increasing the number of the repeated impacts. Such trend is opposite compared to the previous results obtained by other researchers using thermosetting composites.

1 INTRODUCTION

During manufacturing, ordinary maintenance activities or service states, specific composite structures can be subjected to repeated impacts at localised sites, depending on the design geometry and field of application. It is generally acknowledged that laminated composite structures are more susceptible to impact damage than metallic structures [1]. In composite structures, impact loading creates internal damage that can cause severe reduction in the laminate strength and stiffness, even if often the damages are not detectable by visual inspection. Even if the impact damage associated to a single impact event may be slight, the same cannot be said for multiple impacts; the damage accumulation over time, in fact, can seriously weaken the structure reducing its mechanical properties. Under low velocity impact, it is well known from the literature that the first damage is due to matrix cracking [2]. Although, the only matrix crack does not significantly change the overall laminate

stiffness, it tends to act as trigger for other internal damages, such as delamination, fibre breaks, fibre pull-out, fibre/matrix debonding. All these types of damages may dramatically affect the performance of the laminate in terms of load–stroke response. Consequently, the mechanical performance is reduced and it can cause a sudden degradation of the laminate.

Many researchers addressed the topic by performing extensive experimental campaigns where both single and multiple impacts are used to achieve a satisfactory knowledge and prediction of the behaviour of composite structures subjected to impact loadings. When facing single impacts, thermoset composite laminates vary in their absorption capability according to some geometrical and test parameters. Such influence was studied by Cantwell and Morton [3], who were the first to review the impact response of continuous fibre-reinforced composites. They made an extensive review to identify fundamental parameters determining the impact resistance of the concerned materials. Afterwards, Atas et al. [4] performed experimental impact tests on woven fabric composite plates made of E-glass reinforcement and epoxy resin at different energy levels in the range 4–45 J. Through this campaign, they assessed that the damage mechanisms of woven fabric composite plates could be traced from the comparison of the corresponding load-deflection curves, the energy profile diagrams, and the images of the impacted specimens. Papa et al. [5] analysed the matrix and temperature influence on the dynamic response of carbon fibre composite laminates made of vinylester and epoxy resin when impacted at different energy levels by using a falling weight machine. They noted a general better behaviour of vinylester over the epoxy resin, due to the higher amount of energy to obtain fully damaged specimens and the absence of critical temperatures under 0° C. Boria et al. [6] proposed an experimental and numerical study on sandwich structures impacted by a falling weight up to penetration. In particular, they studied hybrid glass/wool-felts laminates characterized by different thicknesses of the glass mat skin and the wool felt core, observing that the insertion of two wool felts instead of one improved the response performance to the impact. However, some pull-out and porosity occurred at the early stages of the impact process, leading to an affected performance of the laminates in terms of the appearance of early damage under impact loading. Finally, Schoeppner and Abrate [7] determined the threshold load level at which a composite laminate starts delaminating when impacted at low velocity, i.e., the load level after which a sudden load drop occurs due to the loss of stiffness for the specimen because of the damage at the laminar level. In order to furnish an accurate approximation of the threshold load, they used about 500 load-time histories from the Air Force Research Laboratory Low Velocity Impact Database, where the impacted specimens are made of graphite fibers and epoxy/PEEK/BMI matrices.

In addition to the aforementioned studies on single low-velocity impacts, many researchers also focused on damage and lifetime prediction of thermoset composite laminates under repeated low-velocity impacts. Found and Howards [8] studied Carbon Fibre Reinforced Polymers (CFRP) laminates subjected to single and repeated impact tests, which made possible to conclude that the impact force rather than the impact energy dictate the failure initiation. Roy et al. [9] were the pioneers in designing impact fatigue studies notched composites, made of a 63.5% amount of glass fibre in vinylester resin. For the first time, they demonstrated an impact fatigue (S-N) curve with an endurance limit; reducing applied impact energy, a progressive endurance was observed. By means of repeated impact fatigue, they analysed the basic failure mechanism: residual strength, modulus and toughness properties were measured on the impact-fatigued samples. Such tests suggested that the composites' failures under impact fatigue were due to a few large cracks in the matrix at high impact endurances, and an increased volume of microcracks with damaged fibres at low impact endurances. Moreover, fractographic analysis revealed severe debonding in the composite samples, with fibre pull-out and fibre breakage in the tensile zone, and shear fracture of fibre bundles in the compressive zone. Hosur et al. [10] revealed that a stitching procedure in the specimens' manufactory process can confine the damage extent. They compared stitched/unstitched S2-glass/epoxy composites by performing low-velocity impacts on 100 x 100 mm samples at energy levels in a 10–80 J range. In a second moment, they extended their study to determine the effect of repeated impact loading, where the laminates were subjected to a maximum of 40-repeated impact, with energy levels from 10 to 50 J. According to the registered peak loads, absorbed energies and projected damage areas, all the laminates successfully faced repeated impact up to 30 J, while better performances depended on the configuration of the single specimen. Sugun et al. [11] investigated the behaviour of different advanced composites – glass,

carbon, and kevlar in epoxy matrix – impacted at low velocity by means of an instrumented drop weight impact testing machine. For impact energies ranging from 3.5 to 15 J, they obtained the number of drops to failure data with simultaneous recording of the load-time and energy-time histories. The experimental campaign suggested that the peak load steadily decreases and the total energy increases until failure with the drop numbers. Moreover, they observed that the tolerated number of drops varies in harmonic progression as the incident energy varies in arithmetic progression. Finally, as done for glass and kevlar composites, final maps of the delamination area help to understand the impact damage tolerance of polymer composites. Morais et al. [12] investigated the laminate thickness influence on the resistance of glass, carbon and aramidic fabrics to repeated low energy impacts. They concluded that the cross section of the laminate is the main variable in determining the impact resistance of the specimen up to a certain impact energy, irrespective of the reinforced fibers composing the laminate, while the fibre characteristics become relevant when increasing the energy level of the impactor. Baucom et al. [13] aimed to understand in detail the effects of reinforcement geometries on damage progression in woven composite laminates (2D-plain-woven, 3D orthogonally woven monolith, biaxially reinforced warp-knit) subjected to repeated impacts. While the 3D woven composites resulted in a larger radial spread of damage if compared to the 2D panels, they showed the greatest resistance to penetration and highest energy absorption than the other systems. This was due to the ability of the 3D composites to control the failure progress thanks to the crimped portion of z-tows. Indeed, they turned out to dissipate energy over a larger area and to furnish a greater perforation strength with an areal density and a fibre-volume-fraction that were comparable to the other systems' ones. Belingardi et al. [14-16] introduced the Damage Index (DI), a new variable able to assess the damage accumulation on thick composite laminates impacted at low velocity. They analysed different fibre-matrix architectures and laminate thicknesses, showing that the DI tended to increase with the different phases of the penetration process, and hence it can effectively distinguish penetration and perforation thresholds. In particular, before penetration occurs, the DI increases linearly with the impact energy, owing to a steady accumulation of damage, while it suddenly increases afterwards, pointing out a change in the rate of damage accumulation. To conclude, Sevkat et al. [17] performed repeated low-velocity impacts on hybrid plain-woven composite panels. They compared non-hybrid S2-glass-fiber/toughened epoxy and IM7 graphite fiber/toughened epoxy to hybrid S2-glass-IM7 graphite fiber/toughened epoxy composite panels. By considering different stacking sequences on repeated impacts, they observed that hybridization helps to delay damage accumulation. In addition, the stacking sequence of the hybrid laminates influenced significantly the damage accumulation rate: the specimens with glass-epoxy skins resisted to a number of repeated impacts equal to the double of the ones supported by specimens with graphite-epoxy skins.

While many works are present in the literature for both single and repeated impact on composite laminates, multiple impacts on thermoplastic laminates have not been widely investigated yet. Only a few studies can be found in this research area. On the one hand, Bora et al. [18] studied the impact-fatigue properties of unidirectional carbon fibre reinforced polyetherimide composites. By using impact energy levels from 0.54 to 0.95 J (corresponding to the energy with fracture by the hammer) for the low-velocity repeated impacts, they presented and validated an analytical model aiming to describe the lifetime of the specimens under repeated impact loadings. On the other hand, Aurrekoetxea et al. [19] performed repeated impacts on self-reinforced polypropylene composites, obtaining plastic deformation of the tape as dominant mechanism and a resulting highly localised penetration mode, with a *star*-shaped hole. Since strain-hardening leads to an increase of the peak load and the plastic deformation decreases at each impact event, the absorbed energy at each impact is consequently reduced. Nonetheless, they concluded that the amount of energy absorbed increases up to perforation when the tape braking occurs.

Recently, self-reinforced polymers, in which both reinforcement and matrix belong to the same polymer family, are spreading as substitutes to glass, carbon and other inorganic reinforcements in composites; this is due to their low cost, lightweight, structurally and environmentally superior behaviours. Between the important safety issues of this class of materials there are the impact performance, the damage tolerance and the durability after impact for structural applications. While carbon and glass fibres can be damaged under low energy impacts reducing strongly the residual properties of the composite [20], the plasticity of composites with thermoplastic fibres tends to reduce

the sensitivity to damage [21]. Moreover, the self-reinforced polymers present an excellent fibre/matrix adhesion without any additional coupling agent. Various researchers have focused their studies on self-reinforced polymers varying polymers and processing routes [22-27], but up to now no exhaustive analysis on repeated impacts at low velocity has been conducted.

In this overview, the goal of the present paper is to investigate the effect of repeated impacts at low velocity on composites made of self-reinforced polypropylene varying the thickness of the laminate and the energy level of the impact. A systematic program of impact testing at low velocity was conducted. The experimental tests were carried out using an instrumented drop-weight equipment. The experimental results were analysed in terms of the characteristic peak load, the absorbed energy, the permanent deflection of laminates, the residual stiffness and the number of impacts to failure in order to assess the impact performance and the damage resistance of the laminates.

2 MATERIAL AND EXPERIMENTAL SET-UP

The material investigated in this work was a composite fully made of thermoplastic. This material is commercially identified with the name PURE[©] thermoplastic. It is a self-reinforced composite made of polypropylene [28]. It relies on co-extrusion of PP tapes using two types of PP with different melting temperatures. These tapes are cold drawn to increase the mechanical properties, and to weld the tapes together using a compaction process. These co-extruded tapes are 100% PP-based and consist of an oriented PP homopolymer core, which provides strength and stiffness to the final laminate, and two thin PP copolymer skins. These skins are positioned above and below the core material and they have a lower melting temperature than the core material. The core material represents the matrix of the composite. The impregnation and the reinforcement manufacturing are achieved in one process-line through the co-extrusion process. These two steps of the manufacturing process are usually separated for the traditional composite materials. In addition, the bonding between the matrix and the reinforcement is achieved in the melt phase prior any orientation of the polymer molecules. The tape can be woven into fabric and subsequently sheets can be made from this fabric by sealing them together. Components made of PURE[©] thermoplastic can be produced by thermoforming using the sheets or the fabric as raw material. The main properties from a mechanical point of view, of the PURE[©], in the tape and in the sheet configuration, are shown in Table 1.

PURE [©] tape	Value	Unit
Width	2.2	mm
Density	732	kg/m ³
Tensile modulus	14	GPa
Tensile strength	500	MPa
Tensile strain to failure	6	%
Flexural modulus	4.5-5.5	GPa
Shrinkage at 130° C	<5.5	%
PURE [©] sheet	Value	Unit
Thickness	0.3	mm
Bulk density	780	kg/m ³
Tensile modulus	5.5	GPa
Tensile strength	200	MPa
Tensile strain to failure	9	%
Flexural modulus	4.5-5.5	GPa
Sealing range	130-180	°C

Table 1: Mechanical characteristics of the PURE[©] according to the technical data sheet [29, 30].

In this work PURE[©] plain fabrics with three different thickness were investigated. These three PURE[©] fabrics were consolidated into sheets using 23, 39 and 53 layers of material respectively. The same stacking sequence was used for all the laminates. For the compaction process the laminates were

put into a hot press at the pressure of 100 bar and at the temperature of 130°C for 2 hours. The final thicknesses of the PURE[®] specimens were about 3, 5 and 7 mm.

Experimental tests following the ASTM 3029 standard [31] were conducted, using the testing machine Ceast 9350. This equipment is based on a drop dart in free-fall. The impact energy was controlled by the drop height and the mass of the impacting device. The specimens were in the shape of square plates (100 mm for each side) and they were clamped during the tests. The specimens were not removed from the clamping device between one impact and the following one. For this reason, it was not possible to observe the damage effect after each single impact. The clamping device (Figure 1) of the drop testing machine was made up of a lower support with a circular opening of 76 mm diameter. During the test, the specimen was placed on the lower support and was clamped by an upper plate with the shape of a circular crown. The inner diameter of the circular crown was again 76 mm. The upper plate was pushed on the surface of the specimen by means of two pneumatic actuators. The impactor head was hemispherical, with a radius of 10 mm, and its mass was 67 kg. The value of the mass was chosen starting from the results reported in our previous work [32], where the influence of the impact mass on the impact behavior of the same type of specimens was investigated. The same impact mass was used for all the experimental tests. The impact energy was set at three different levels by changing the falling height: 18.5, 33.5 and 66.5 J respectively. The values of the impact energy were defined again starting from the results reported in our previous work [32]. These energy levels will be named in this paper as 1, 2 and 3, respectively. The plan of the experimental tests was based on the repetitions of the impacts on the same specimen and at the same level of the impact energy up to 40 times. It was not possible to carry out 40 impacts in all the considered configurations, due to the behavior of the specimens. A summary of the different considered configurations for the tests is reported in Table 2

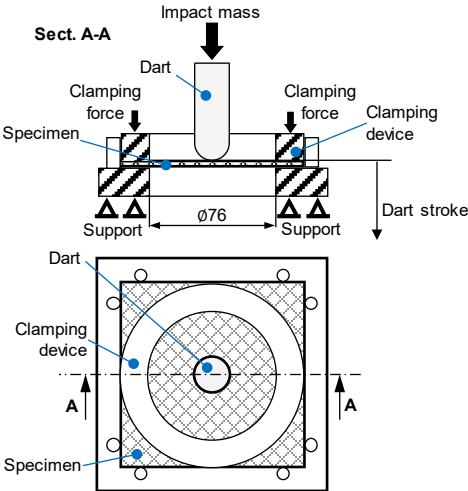

Figure 1: Configuration of the drop-dart test and the clamping device.

Thickness (mm)	Mass (kg)	Impact energy (J)	Energy level	Impact velocity (m/s)
7	67	24.2	1	0.85
	67	41	2	1.11
	67	76.2	3	1.51
5	67	24.2	1	0.85
	67	41	2	1.11
	67	76.2	3	1.51
3	67	24.2	1	0.85

Table 2: Summary of the set-up of the experimental tests.

The displacement of the dart, starting from the instant in which dart and specimen come into contact, and the load exchanged in the contact between the dart and the specimen were the parameters investigated during the tests. For what concerns the load, its measure was recorded from a piezoelectric cell mounted just before the dart. The energy absorbed during the tests was the third experimental parameters evaluated for each test. The absorbed energy was the energy absorbed by the specimen during the impact event and it was calculated as the integral of the force-displacement curve. Therefore, the diagrams of the absorbed energy are cut off at the instant when the load nullifies.

3 EXPERIMENTAL RESULTS

The number of the impacts and the type of the deformation obtained in each configuration are collected in Table 3. For what concerns the type of the deformation, a first classification is given in this table whereas a more detailed analysis is provided in the following.

Thickness (mm)	Energy level	Number of impacts	Type of deformation
7	1	40	No fracture
	2	40	No fracture
	3	17	Slip of the specimen
5	1	40	No fracture
	2	7	Perforation
	3	4	Perforation
3	1	2	Perforation

Table 3: Experimental results.

Examining first the thickest specimens, it is evident how 40 impacts on the laminate were performed without getting fracture or perforation for the first two levels of the impact energy. Different result was obtained with the third level of energy. Neither fracture nor perforation were found. A slip of the specimen out of the clamping device was get. The clamping surface, defined according to the ASTM 3029 standard [31], was not enough to avoid the slip of the specimen due to the particular deformation of the specimens with the highest thickness, as discussed in more detail in the following.

No fracture or perforation were obtained after 40 impacts for what concerns the specimens 5 mm thick, considering the first energy level. The complete perforation of the specimen was obtained after few impacts increasing the energy to the level 2. The trend was also confirmed using the third level of

energy. For what concerns the specimen with the lowest value of the thickness, as expected, the perforation after only two impacts was found. Consequently, only one level of impact energy was taken into account for the specimens with the lowest thickness. This value of energy was the minimum achievable using the equipment described above, when the value of the impact mass adopted for these tests is used.

The load-displacement and the energy-displacement curves obtained in the experimental tests, at the first impact, for the specimen 7 mm thick are summarized in Figure 2-a and 2-b, respectively. The hysteresis cycles for all the impact energies show no internal damage of the laminates and a rebound of the dart after the impact phase. A plastic deformation can also be noted from such diagrams, because the unloading phases do not return to zero displacements. The displacement recorded during the unloading phase, when the load vanishes, represents the indentation suffered by the laminate subjected to impact. The maximum load reached during test, the maximum displacement and the absorbed energy increased increasing the level of the impact energy as discussed in the literature [32]. The curves presented the same trends for the different level of the impact energy whereas the deformation increased increasing the level of the energy. The slope of the load-displacement curve at the first linear stage was used to define the stiffness of the specimen. Such parameters proved to be useful to analyze the experimental results and were considered in the subsequent analyzes.

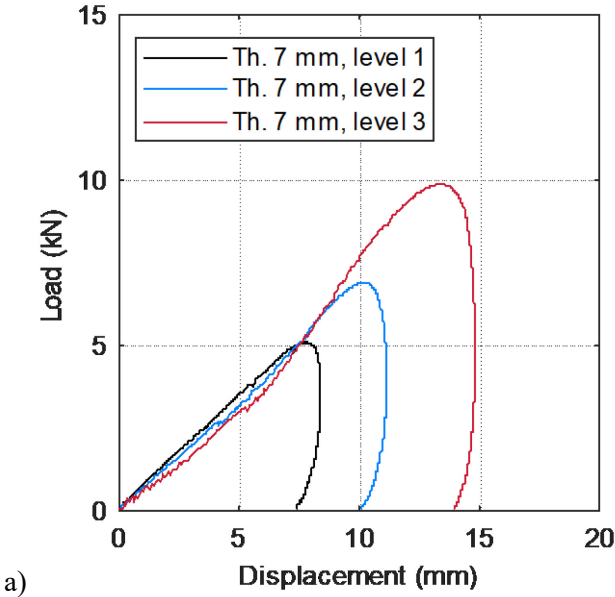

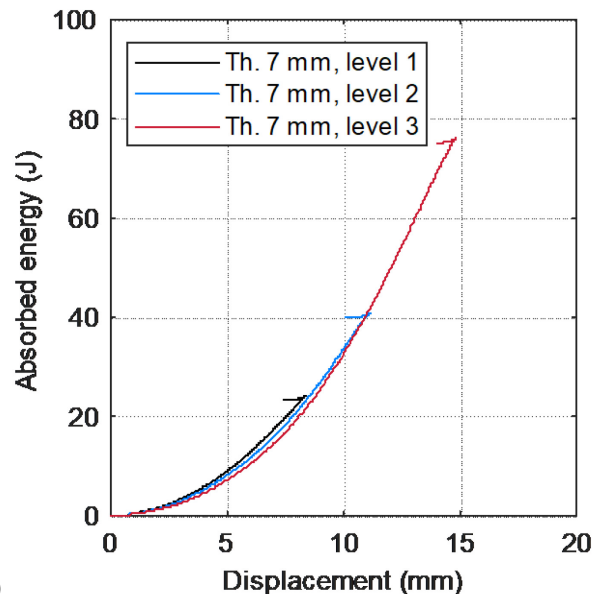
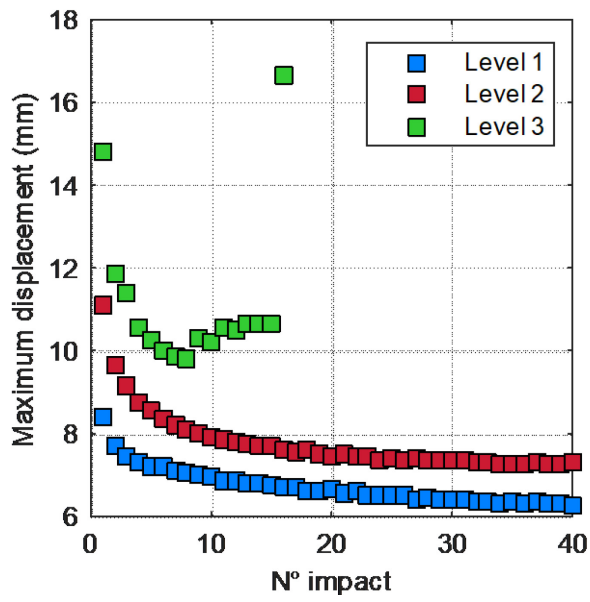

Figure 2: Force vs. displacement (a) and energy vs. displacement (b) curves for the different considered configurations. The curves refer to the first impact.

In the Figure 3 it is possible to see the trend of the maximum displacement of the drop dart (Figure 3-a), the maximum load (Figure 3-b) and the maximum absorbed energy (Figure 3-c) as a function of the number of impacts. These results refer to the specimens with the highest thickness and the influence of the energy level can be observed. Less experimental points were recorded at the highest energy level because the perforation of the specimen was obtained.

The rate to the permanent deflection of the laminates of each impact event (Figure 3-a) reveals that the maximum plastic deformation appeared after the first impact event whereas the other impacts showed a slighter influence on this parameter. This phenomenon is not influenced by the value of the impact energy because it was observed in the same way for the three levels of energy. The contribution of the impacts to the deflection and thus to the deformation of the specimen was consistent only up to about the tenth impact. It is evident as, after the tenth impact, the dart displacement reduced faster than the first ten impacts. This behavior can be justified by the strain-hardened nature of the impacted specimen. As expected, the absorbed energy tends to decrease increasing the number of the impact. The peak load showed an unusual trend: the maximum load increased with the number of the impacts. Previous work [33] on composites made with thermosetting resin and reinforced with glass fibers showed the opposite behavior. The difference between the two behaviors was due to the difference between the thermoset and the thermoplastic materials. Glass fibers can be damaged by loads due to impact with low energy. These impacts reduced the residual properties of the composites. In the other case, the composites made of thermoplastic fiber are less sensitive to damage due to their plasticity.



a)

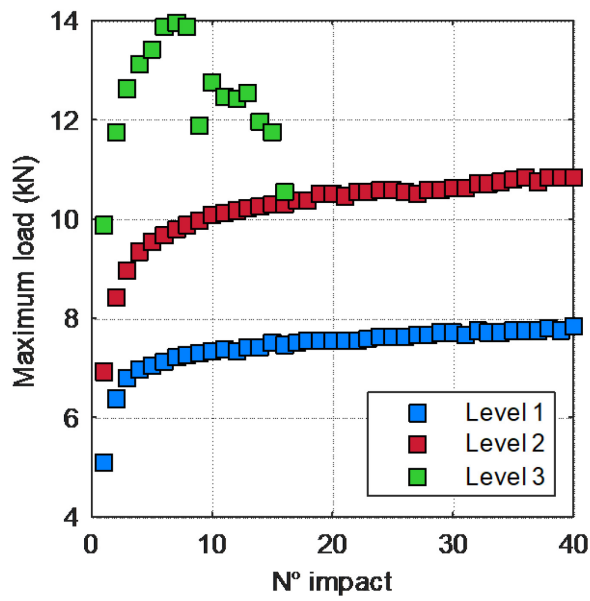

b)

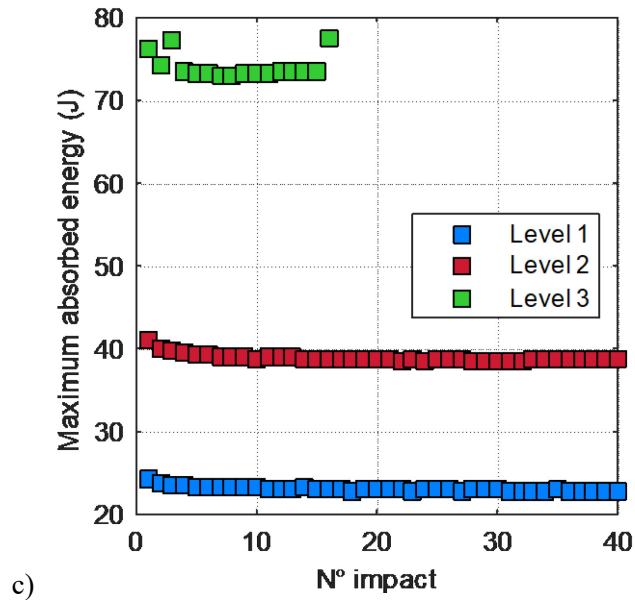
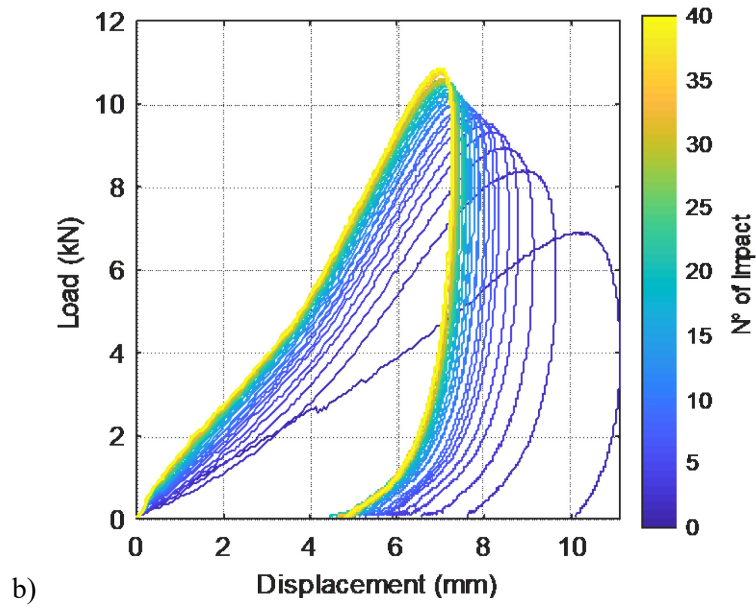
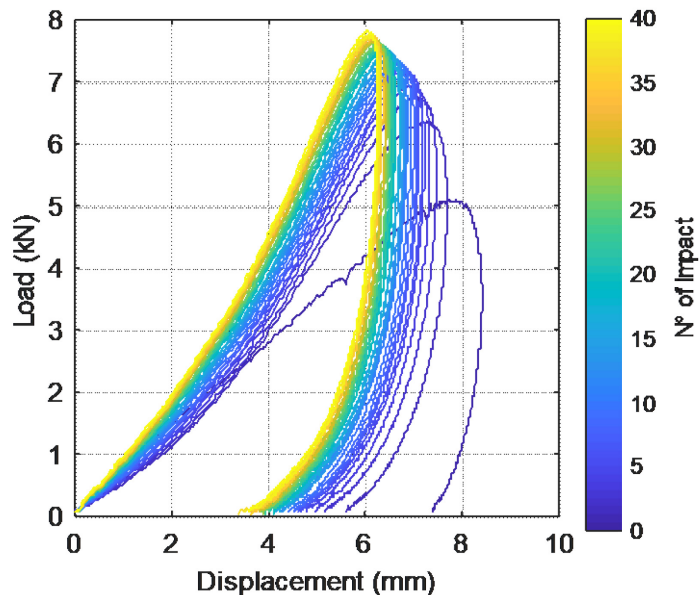

Figure 3: Experimental results for the specimen with thickness of 7 mm as a function of the number of impact: a) maximum displacement, b) maximum load, c) maximum absorbed energy

The curves of load versus the displacement of the dart obtained in all the experimental impacts on the specimen with the thickness of 7 mm are shown in Figure 4 for the three levels of the impact energy (Figure 4-a, 4-b and 4-c respectively). In the same way, the absorbed energies as a function of the displacement of the dart are reported in Figure 5. These charts showed as the stiffness of the specimens tends to increase with the increase of the number of the impacts. This trend was still conversely compared to the behavior of more conventional composites in terms of material that was widely discussed in literature [34]. The shape of the curve on the load vs displacement chart can be used to understand the damage mode and the corresponding behavior of the composite. The curves in the Figure 4 had a closed form. This shape indicates a non-perforated sample. Moreover, the curves did not show any fluctuations. This behavior usually means the absence of matrix crack and of fiber fracture. Furthermore, the rounded shape of the diagrams gave an idea on the main damage mechanism, that is the plastic deformation of both the fibers and the matrix. The curves showed for all the impacts the same general shape. The shape became narrower and higher increasing the number of the impact. The difference between the first and the other impacts can be due to the compaction of the laminae after the first impact. This phenomenon tended to increase the stiffness of the specimen. Such behavior was less evident considering a lower number of compacted sheets, as discussed in the following. The charts clearly showed the presence of residual deflection at the end of each impact, that tends to reduce increasing the number of impacts. This residual deflection can be defined as the value of the displacement when the load came back to zero. Such trend of the residual deflection can be justified by the compaction of the internal laminae, which tended to stiffen the specimen reducing its deformation. In Figure 4-c it is possible to see as the last curve was out of trend: in that test the specimen slipped out the clamping mechanism.



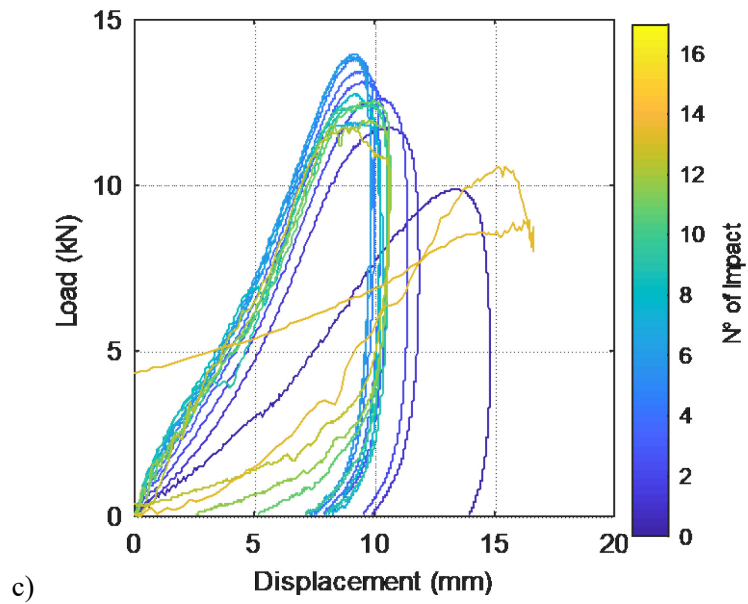
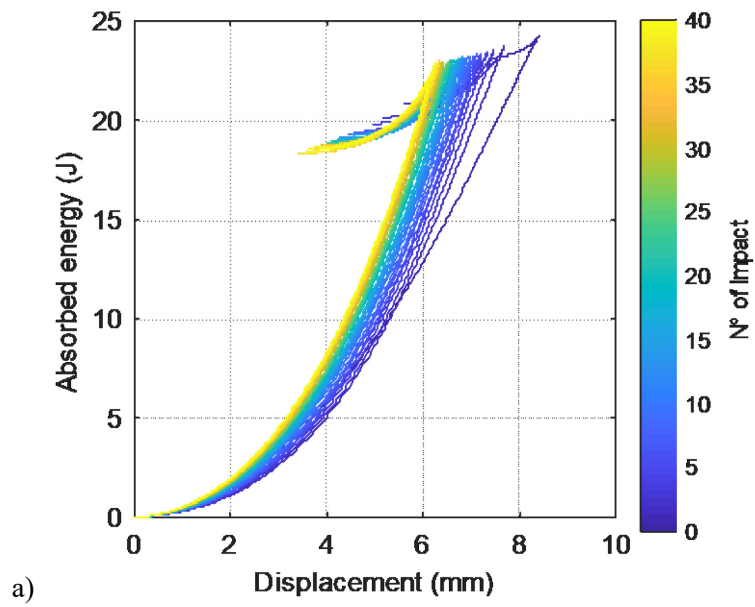

Figure 4: Force versus dart displacement curves for the specimen with a thickness of 7 mm for the three energy levels. In particular from top to bottom energy level 1, energy level 2, energy level 3 respectively



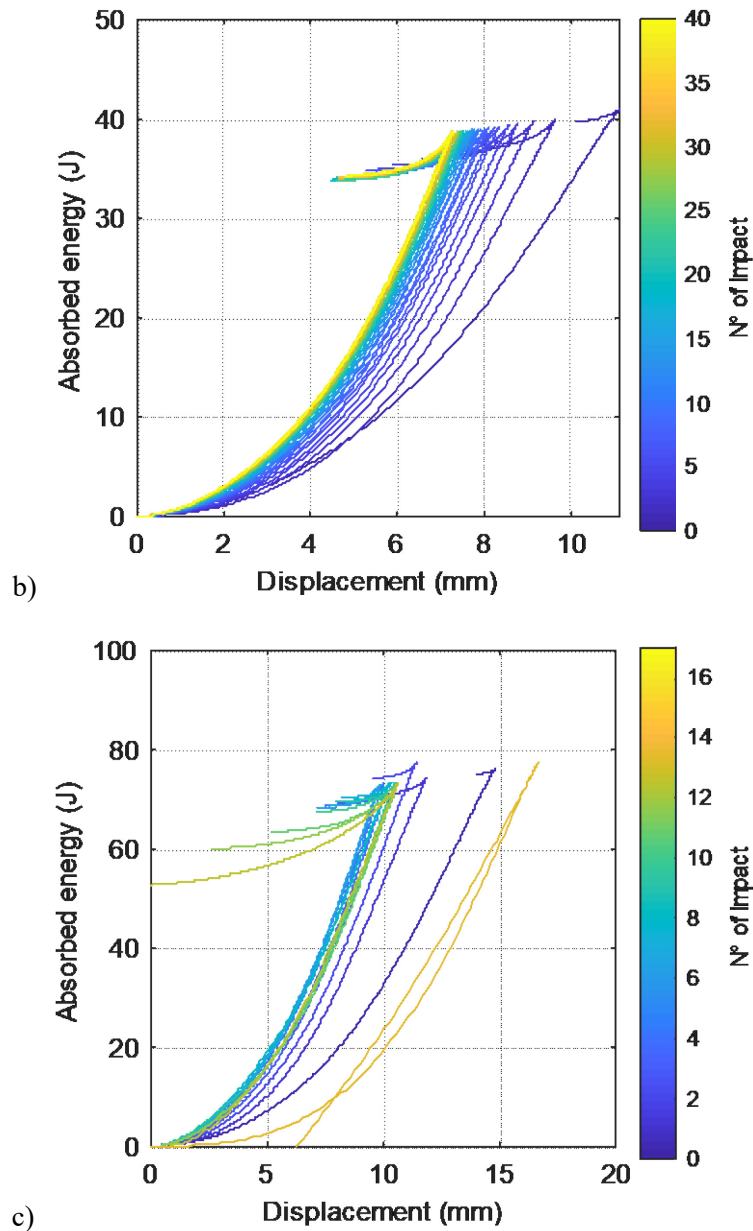

Figure 5: Absorbed energy versus dart displacement curves for the specimen 7 mm thick at the three energy levels. In particular, from top to bottom energy level 1, energy level 2, energy level 3 respectively

The Figure 6 shows some photos of the specimen 7 mm thick after tests. The figure allows to understand the impact process and the damage of the laminates. The impacted surface (indicated as front in the figure) and the non-impacted one (indicated as back in the figure) showed damage propagation. On the rear side in all the examined cases a conical deformation was evident, whereas on the front side a cup deformation concentrated around the impact point was noticed. Moreover, a cross shape sliding could be noticed for the yarns situated directly under the impactor. In the warp (0°) and weft directions (90°) can be found the damage propagation. This deformation was more evident when a grow of the impact energy was applied. With the highest energy level, after a certain number of impacts the specimen was slipped away from the clamping device. The examination of the specimen after the tests (Figure 6-c) showed a certain amount of delamination without perforation. The type of deformation is quite evident in the Figure, in particular in the picture on the right, where the specimen is shown in a side view. It is possible to observe four different layers of materials which are slipped each other. They are detached in the central part where the material is subjected to a traction toward

the center of the specimen due to the action of the dart. The delamination phenomenon was caused by the breaking of the molecular chain of the polypropylene in each interface layer. Accordingly, the kinetic energy of the impact broke the fibers with a resultant fiber damage. The specimen showed a soft behavior, something like a handkerchief, behavior that could result very interesting for impact and ballistic applications [35-37].

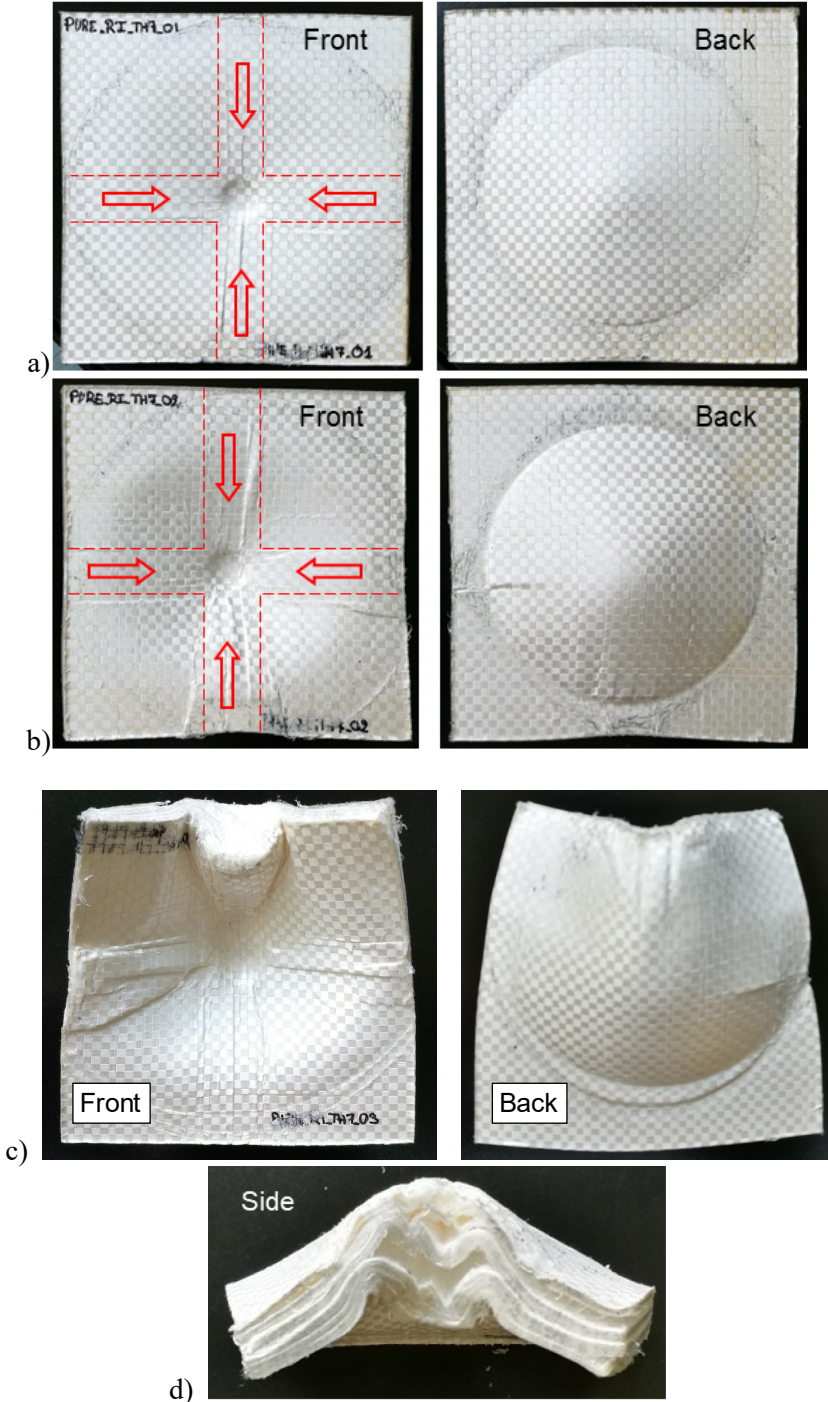
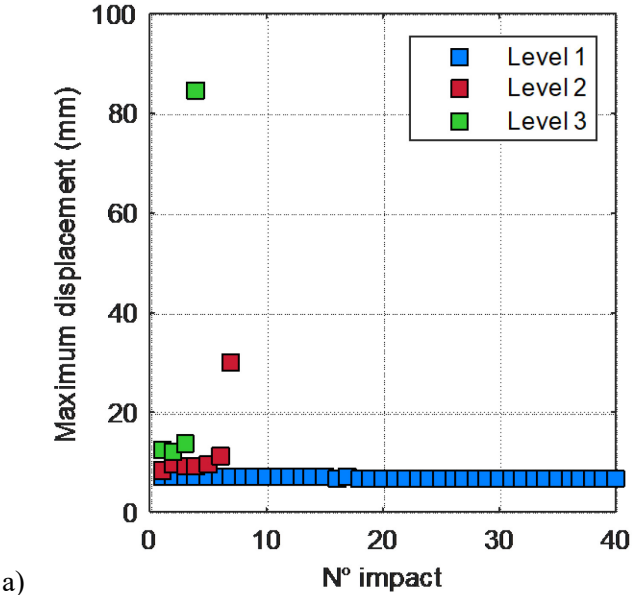

Figure 6: Photos of samples with a thickness of 7 mm after the impacts. The specimens subjected to the three different energy of impact are shown: a) level 1, b) level 2, c) level 3 (front and back view of the specimen), d) level 3 (side view of the specimen)

The specimen 5 mm thick were studied examining the same results discussed above. The Figure 7 shows the trend of the maximum dart moving (Figure 7-a), the maximum load (Figure 7-b) and the

maximum absorbed energy (Figure 7-c) as a function of the number of the repetition of the impact. These results referred to all the impacts at the various levels of energy. The trend of the maximum load can be subdivided into regions depending on the level of the impact energy that is considered. The peak load values increased with the impact events for the first level of the impact energy. This behavior was related to the strain-hardening mechanism that can be observed in the tensile-impact tests [19,38]. The slope of this initial stage tended to increase growing the impact energy whereas, the extent of this region (in terms of number of impacts) decreased with the impact energy. It represents the totality of the repeated impacts for energies up to 24.2 J, whereas for the second and the third level of energy it is limited to just 7 and 4 impact events, respectively. The traditional composites made of thermosetting shown a completely opposite behavior [33]. They revealed the different deformation and fracture micro-mechanisms of the self-reinforced polymers under impact loadings. For the impacts at the second and third level of energy, a second region with a sharply drop of the maximum load until penetration was observed. The drop becomes sharper increasing the impact energy. The absorbed energy decreased with the impact events when the plastic deformation was induced, as it was happened for thicker specimens. At higher energy levels an opposite trend was observed; the absorbed energy tends to increase. The reason for this tendency change can be attributed to the variation of the deformation mechanism, that changes from plastic deformation to tape breakage. This phenomenon can also be observed into the hysteresis curves at the penetration, that show a lower peak load but a higher displacement value.



a)

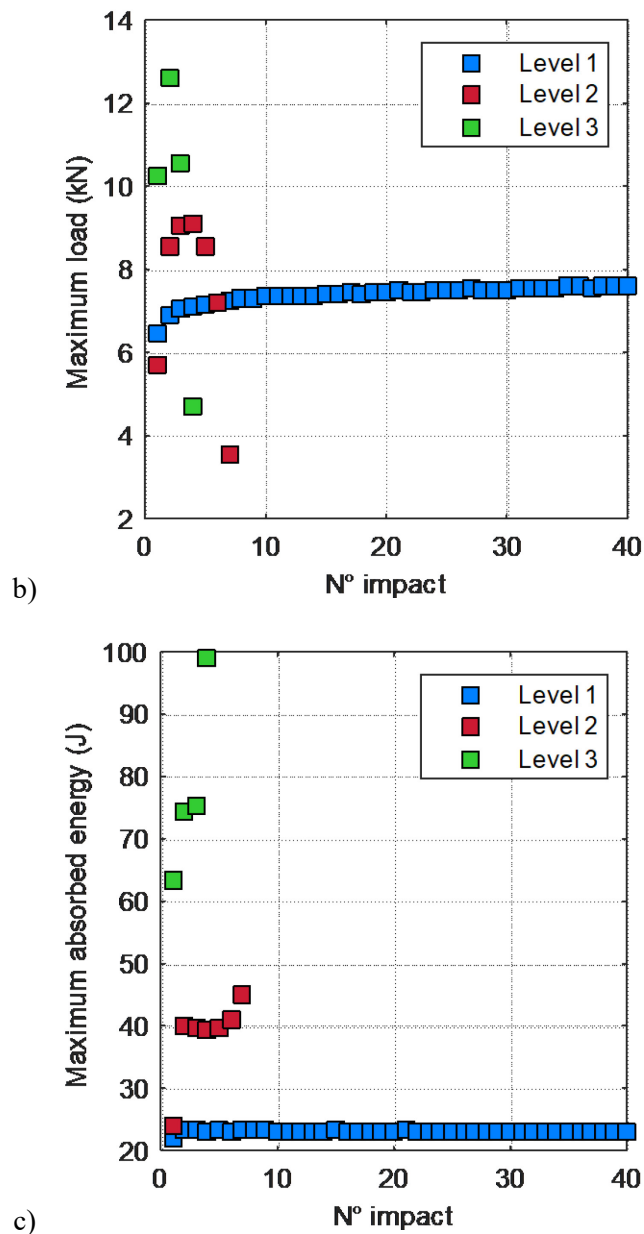
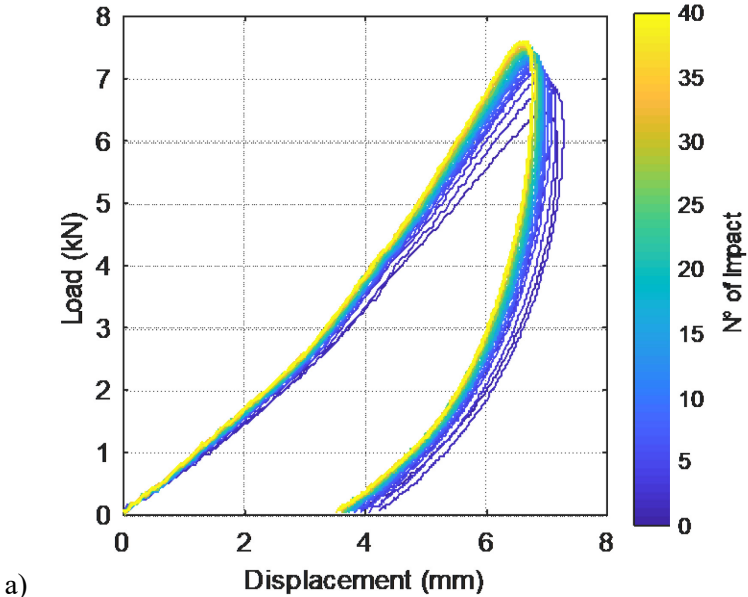

Figure 7: Experimental results for the specimen 5 mm thick as a function of the number of impact: a) maximum displacement, b) maximum load, c) maximum absorbed energy

Figure 8 shows the diagrams of force as function of displacement recorded in the different tests of impacts on the specimens 5 mm thick. The absorbed energy as a function of the displacement is represented in Figure 9. In this case it is possible to also observe the same trend examined before. It was also evident an increase of the slope of the curves increasing the number of the impacts in such thickness condition even if with less evidence than for the higher thickness. This trend is true until the perforation of the laminate, from this last condition an opposite behavior was observed. The increase of the slope at multiple impacts was in disagree with the experimental evidence obtained with the thermoset composites. The shape of the load vs displacement curves obtained after 40 impacts (Figure 8-a) without the penetration of the specimen was the same obtained with the thicker specimen (Figure 4-a). The shape of the curves for the thinner specimen was narrower and higher than those of thicker specimen. The rounded shape of the curves pointed out the main damage mechanism, that was the plastic deformation of both the fibers and the matrix. A transition from round shape to load drop after the peak of the sixth impact for the second level of the impact energy can be observed from the impact

curves (Figure 8-b). Such aspect was correlated to the transition from plastic deformation to tape breakage. Finally, at the seventh impact a perforation of the specimen was observed. With the third level of impact energy the damage accumulation was faster (Figure 8-c): the fourth impact induced severe damage implying the perforation of the specimen.



a)

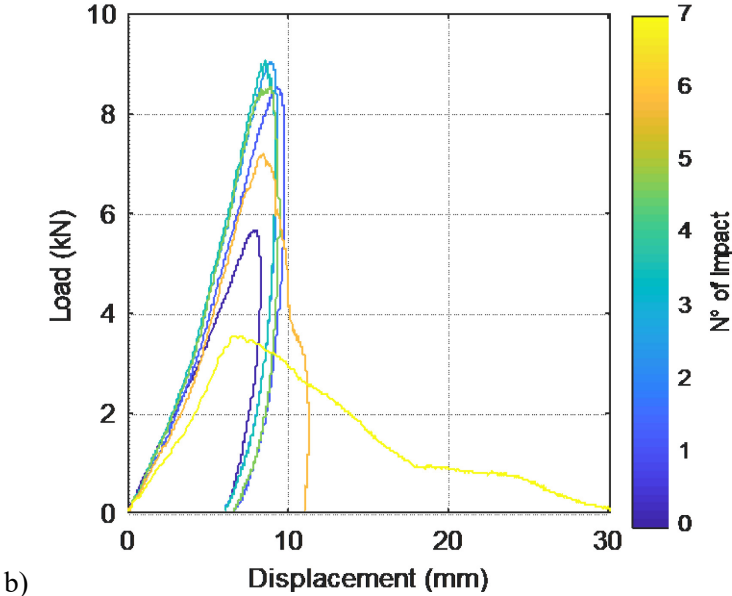

b)

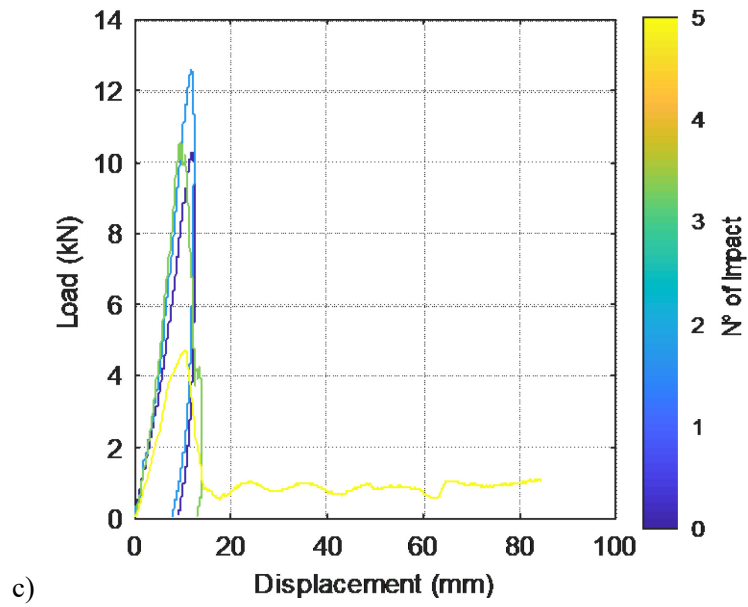
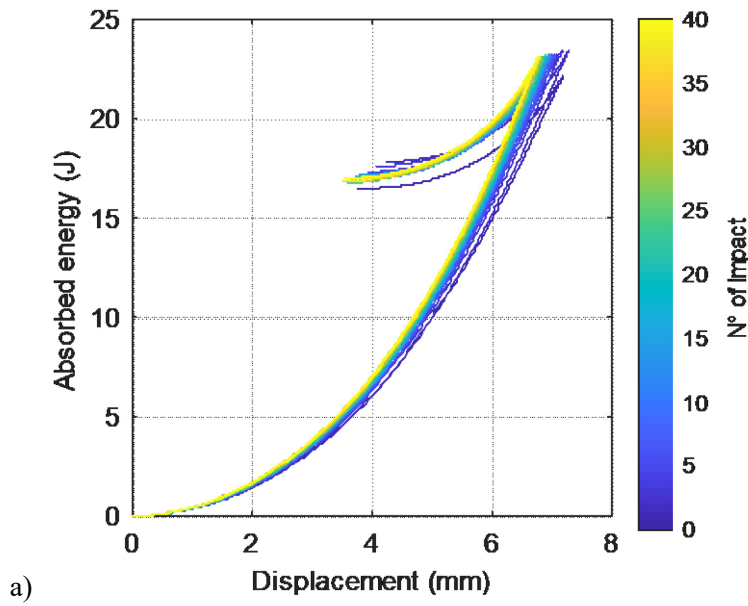

Figure 8: Load versus dart displacement curves for the specimen 5 mm thick for the three energy levels. In particular, from top to bottom: energy level 1, energy level 2, energy level 3 respectively.



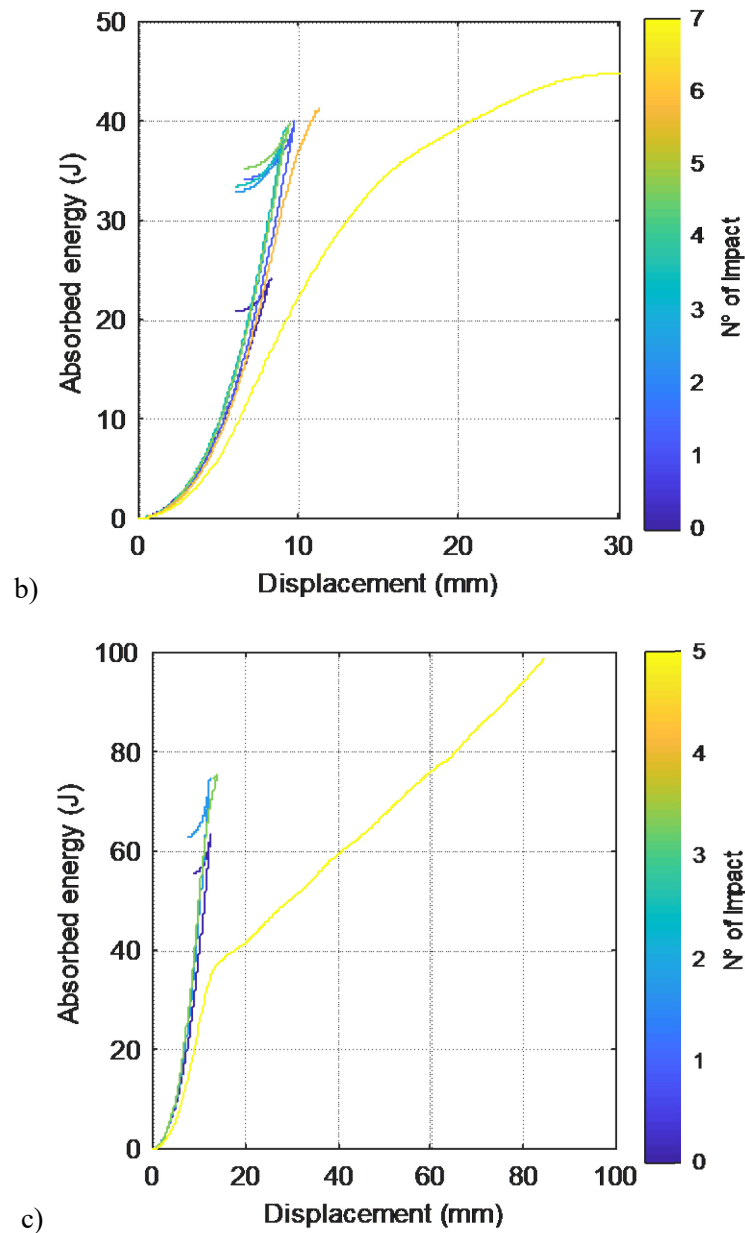

Figure 9: Absorbed energy versus dart displacement curves for the specimen 5 mm thick for the three energy levels. In particular, from top to bottom: energy level 1, energy level 2, energy level 3.

The lowest level of energy was too high to perform repeated impacts on the specimen with a thickness of 3 mm, as shown in Table 3. Therefore, the results on this type of specimen are discussed only considering a single impact and the charts are not reported.

From the strain point of view, a much more concentrated deformation on the top surface around the impact point was evident for both the specimens with a thickness of 3 and 5 mm, compared to the specimens with a thickness of 7 mm. This behavior is opposite to the evidence obtained with the traditional thermosetting laminates, for which lower thicknesses are more likely to bend whereas the thicker laminates are more prone to surface deformations. This observation can be attributed to the different physical nature of the thermoplastic laminates examined in this work. In the PURE© thermoplastic, the plastic deformation plays an important role in the energy absorption, that is not present in the traditional composites. The damage propagation was along the warp and weft directions, as evident on the back face, contrary to what happened for FRP laminates, where the damage tended to propagate along the weaker 45° direction [39]. Increasing the thickness of the specimen, it was evident

a cross yarn sliding along the 0° and 90° direction on the top surface and the formation of a conical tip in the rear skin. Only the area under the dart surface was subjected to deformation in the specimens with the smaller thicknesses. On these specimens a more extensive damage was present on the non-impacted side (Figure 10). The shape of the damaged zone penetrated inside the specimen reflected the deformation mechanisms of the tape. Specimens consolidated at high temperature and pressure, as in this study, showed very localized damage and breakage along tape boundaries giving a characteristic star-shaped indentation [40]. A characteristic star-shaped penetration was shown in Figure 10-b; this is due to tape breakage and tearing along tape boundaries. The plastically deformed zones in the 45° direction to the tapes and the fibre breakage in the 0° and 90° directions were evident. The origin of the star-shaped hole of the penetration can be found into the anisotropic nature of the composite. Such result was in agreement with the research work of Alcock et al. [40] and Aurrekoetxea et al. [19] for all-polypropylene composites.

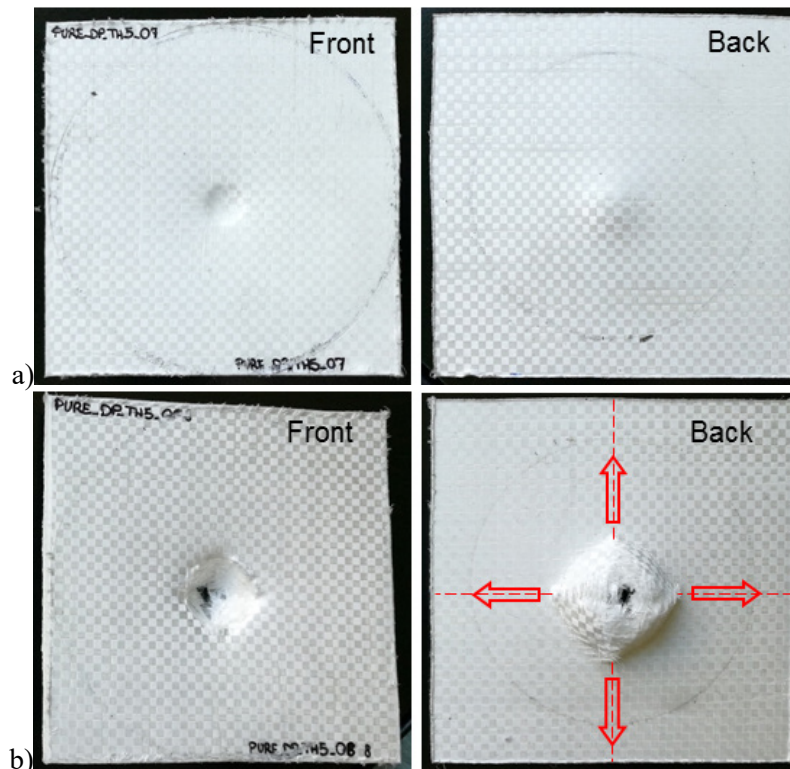
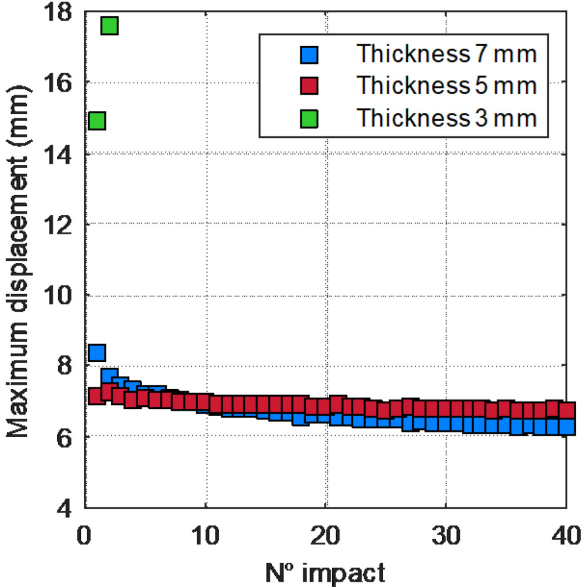

Figure 10: Photos of the samples with a thickness of 5 mm after the repetition of the impacts. Specimens tested with different impact energy are reported: a) energy level 1, b) energy level 2

Figure 11 shows the trend of the maximum displacement of the dart, the maximum load and the maximum absorbed energy varying the impacts number for the specimens with the three considered thicknesses and referring to the first energy level. The charts put in evidence the same behaviors already discussed before, for specimens 7 and 5 mm thick. In particular, the biggest deformation is induced at the initial impact event and then tends to a plateau value increasing the number of impacts. The peak loads tend to increase and the absorbed energies tend to decrease with the number of the impacts. Opposite trends are recorded for specimens 3 mm thick, where the small thickness induces to a premature perforation of the laminate. Moreover, it was interesting to observe the cross between the trends for the specimens with a thickness of 7 and 5 mm in the first ten impacts. There was evident a change in the damage behavior of the specimen depending on the thickness as put in evidence in previous works [41-43]. the impact damage was more extensive in the thermoplastic thinner laminates than in the thicker ones as discussed by the authors in a previous work [41]. The impact damage was detected in the upper layers in the thicker specimens. The initiation and the growth of the delamination was much more evident for the specimens with the high thickness, whereas for the thinner specimens the matrix crack and the tape fracture were the main damage mechanisms. Abrate et al. [42]

demonstrated also the strict influence of the laminate thickness on the threshold load of delamination, using a thermosetting matrix. Belingardi et al. [43] analysed the influence of the thickness of a thermosetting laminate on the first damage force, on the saturation energy and on the plate flexural stiffness connected with the damage degree.



a)

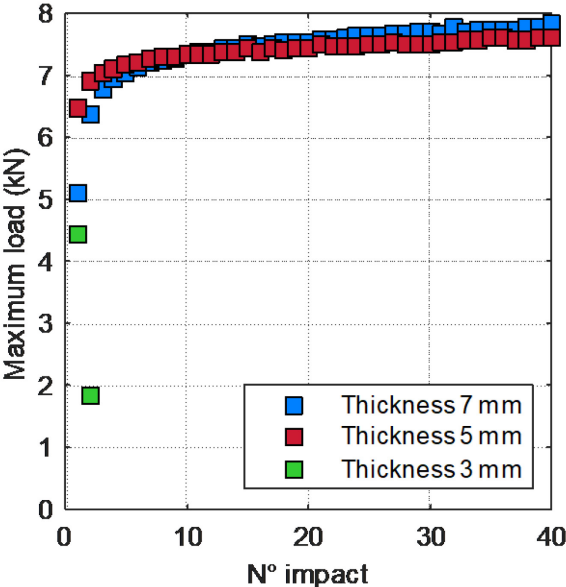

b)

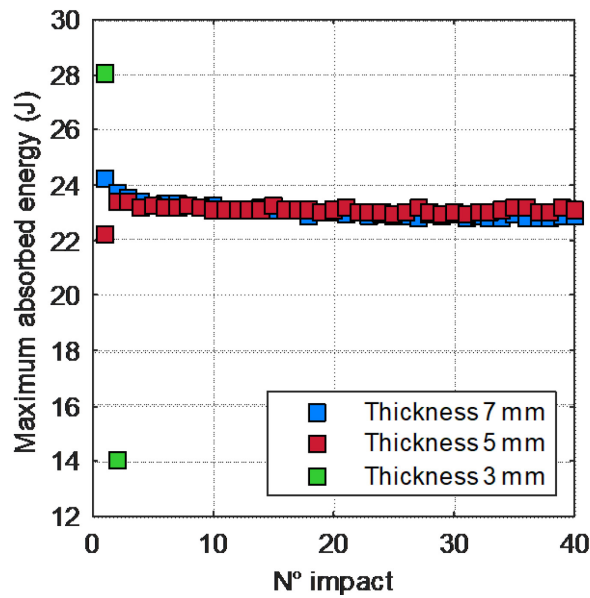

c)

Figure 11: Experimental results for the specimens with the three considered thicknesses at the lowest energy level, as a function of the number of the impact:

a) maximum displacement, b) maximum load, c) maximum absorbed energy

Two important parameters to evaluate the impact response and the resistance of composite structures were the impact energy and the absorbed one. The first was defined as the total amount of the energy applied to the specimen, while the absorbed energy was defined as the area under the force-displacement diagram. The “energy profile” diagram showed the relationship between the impact and the absorbed energy. This diagram was used to summarize the results: the absorbed energy versus the impacted energy for all the experimental configurations was plotted (Figure 12).

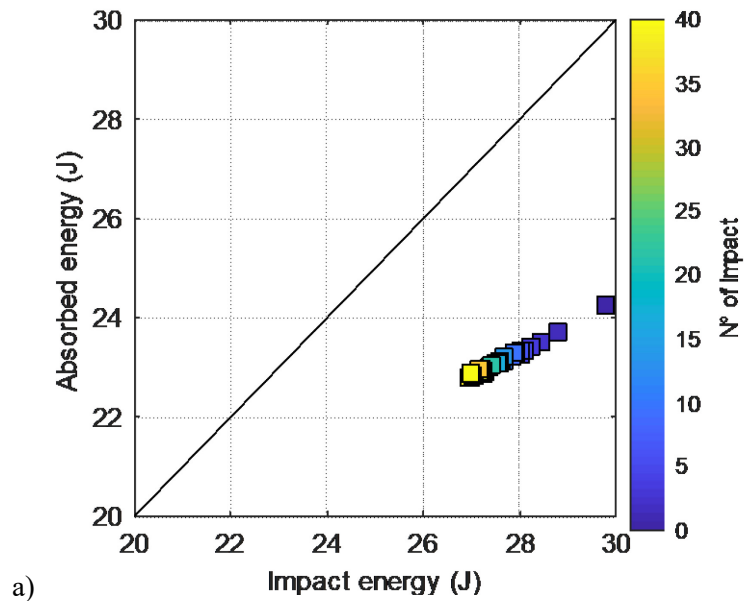

a)

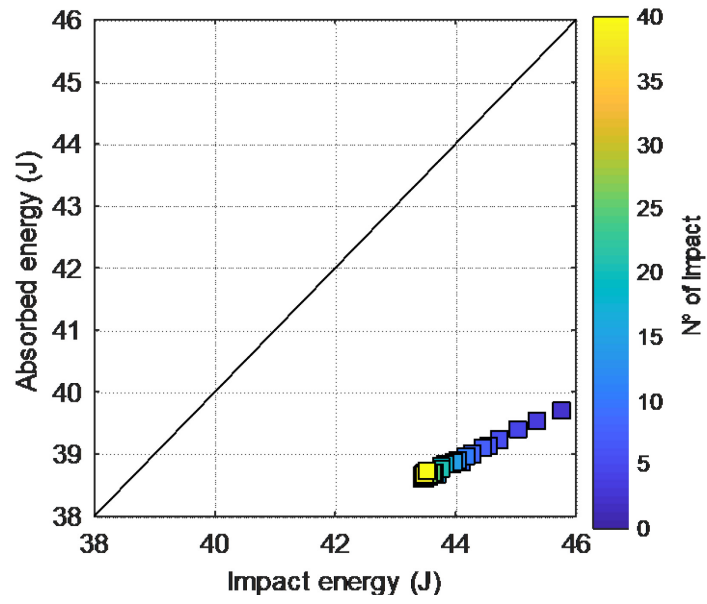

b)

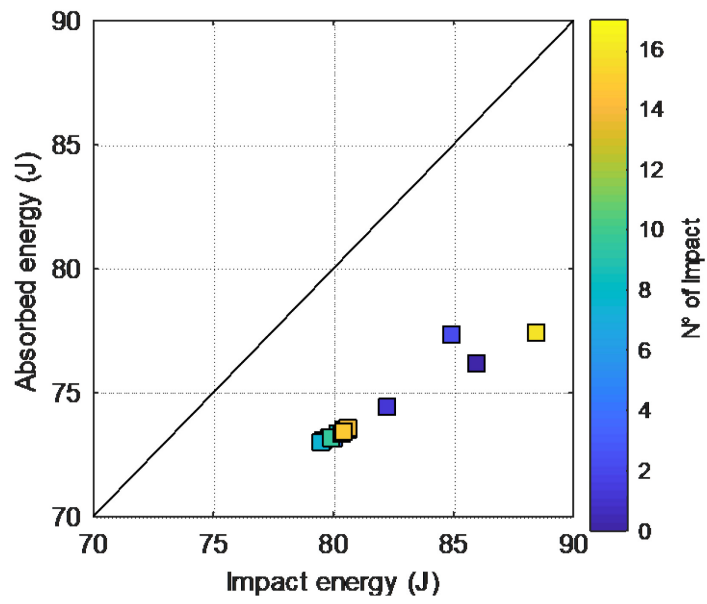

c)

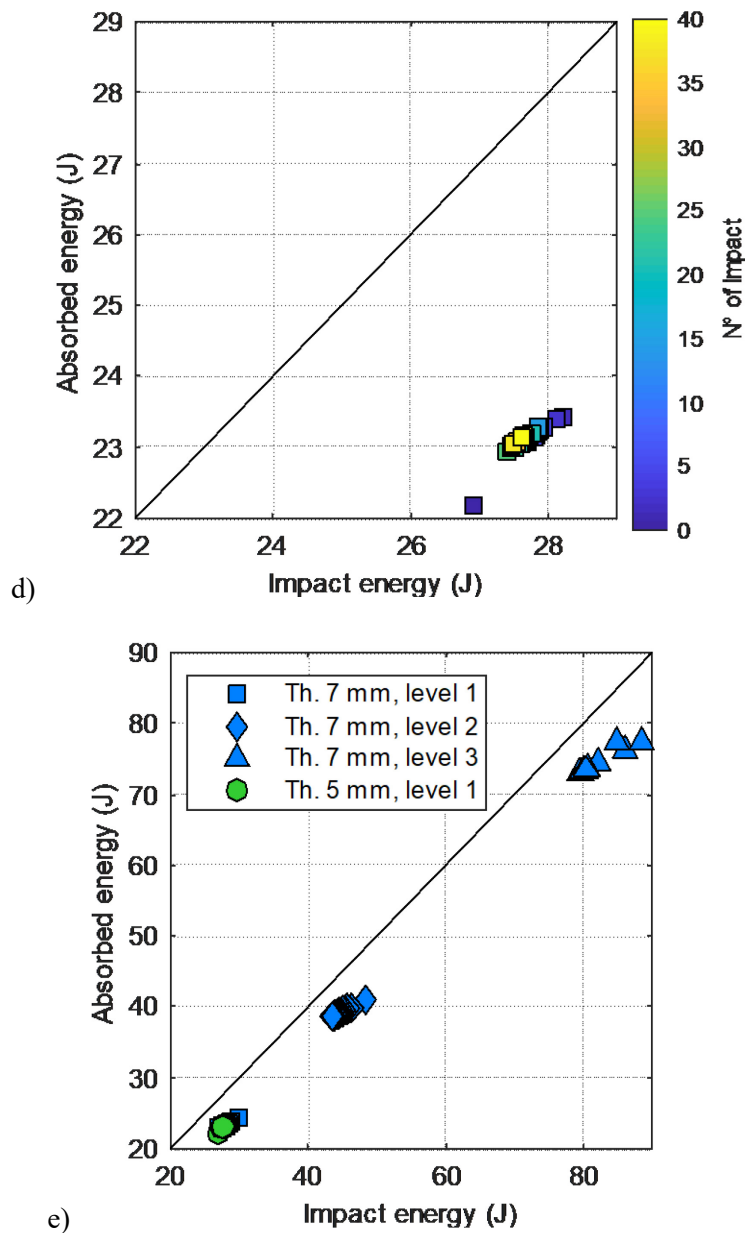

Figure 12: Energy profile for the different experimental configurations: a) specimen 7 mm thick, energy level 1; b) specimen 7 mm thick, energy level 2, c) specimen 7 mm thick, energy level 3, d) specimen 5 mm thick, energy level 1, e) amount of the results shown in the charts a-d summarized in a single chart

The Figure 12 allows an overview of the experimental results: they were positioned not far from the bisector line. In order to account for damage accumulation in thin laminates, Belingardi and Vadori [43] introduced the damage degree (DD). It was defined as the ratio between the absorbed energy E_a and the impact energy E_i ; the DD tended to increase rather linearly with the impact energy up to reach the unit value at laminate penetration. Increasing the number of the impact the absorbed energy decrease. Evaluating the DD, for each case, increasing the number of the impact the DD tends to increase. Figure 13 shows the DD as a function of the specific impact energy. The specific impact energy was defined as the ratio between the impact energy and the number of layers for each specimen. The figure reports the results for the different configurations of impact considered in this work. It can be noted how approaching the perforation condition the DD value tended to one. Moreover, it is also evident how such damage parameter tends to grow slowly increasing the number of impacts on the same laminate. It means that since the first impact it is possible to evaluate, using

such parameter of accumulation damage parameter, the ability of the laminate to sustain multiple impacts. Higher the distance of this parameter from value 1, higher the capability of the material to absorb impact energy repeatedly.

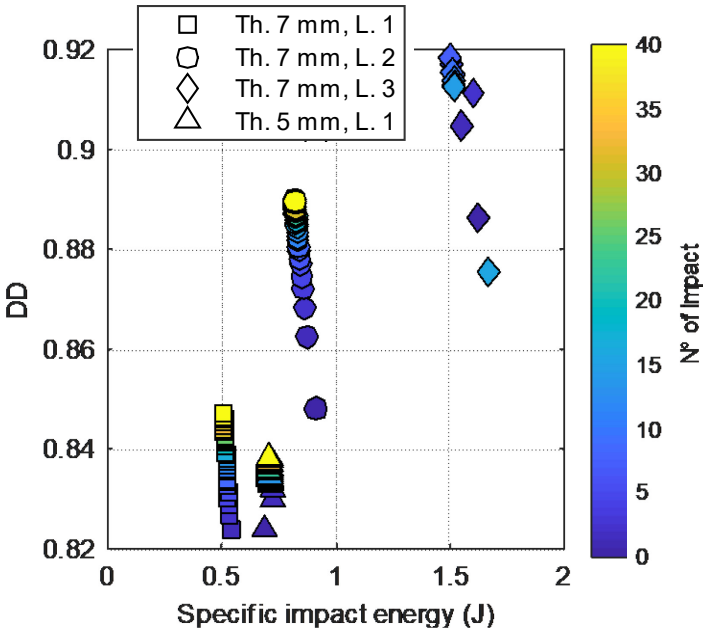
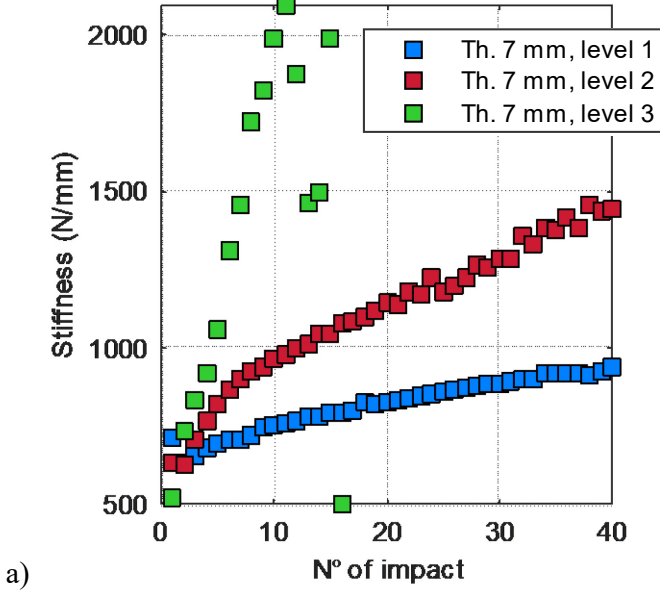

Figure 13: Damage degree versus specific impact energy for the different configurations of the impact tests.

The Figure 14 shows how the stiffness of the specimen changed with the number of impacts, for the different configurations considered in the work. As mentioned before, the stiffness increased with the number of impacts. Such growth was much more marked increasing the impact energy.



a)

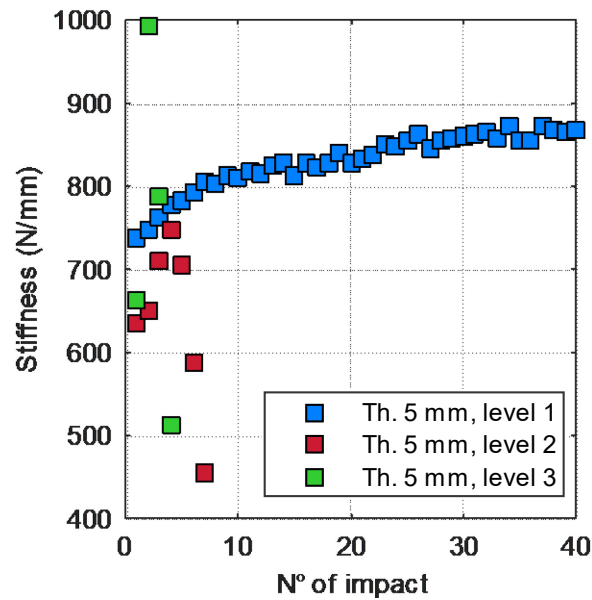

Figure 14: Stiffness of the specimen versus the number of impact for the different configurations of the impact tests: a) specimens with a thickness of 7 mm, b) specimens with a thickness of 5 mm.

4 CONCLUSIONS

In the present paper the results of a series of repeated impact tests conducted on self-reinforced polypropylene composites (PURE[®] thermoplastic) were presented. The damage behavior for different thicknesses of the laminate and for different impact energy levels were analyzed. The impacts were repeated up to 40 repetitions or up to perforation if this phenomenon happened for a number of impacts lower than 40.

The PURE[®] thermoplastic showed excellent impact properties. In more details, the perforation of the specimens was obtained only with low thickness and using the highest available values of the impact energy. The specimens with the highest thickness showed a deformation behavior quite particular, that has been documented and analyzed in some detail. It can result very useful for bulletproof applications. During the penetration of the dart, the failure mechanism was dominated mainly by the plastic deformation of the external tape. The penetration mode was a highly localized star-shaped hole.

Considering the load exchanged at the contact zone between the surface of the specimen and the dart, the peak values increased with the number of the impacts due to the strain-hardening behavior of the material. Contrarily, the values of the peak load decreased when the breaking of the tape took place. Very interestingly the material showed an increase of its stiffness increasing the number of the impacts. Moreover, the absorbed energy decreased with the number of the impact events when plastic deformation was induced. However, the absorbed energy tended to increase when the starting of the tape break was observed.

These results highlighted and confirmed the peculiar behavior of such class of material when compared to the traditional thermosetting composites.

REFERENCES

- [1] S. Abrate, 1998, "Impact on composite structures". Cambridge University Press.
- [2] N.K.Naik, S.Meduri, Damage in woven-fabric composites subjected to low-velocity impact, Composites Science and Technology, 60, 731-744, 2000.
- [3] W.J.Cantwell, J.Morton, The impact resistance of composite materials: a review, Composites, 22 (15), 347-362, 1991.

- [4] C.Atas, O.Sayman, An overall view on impact response of woven fabric composite plates, *Composite Structures*, 82, 336-345, 2008.
- [5] I. Papa, A. Langella, V. Lopresto, CFRP laminates impacted at low velocity: influence of the matrix and temperature, *AIP Conference Proceedings* 1981, 020027, 2018.
- [6] S.Boria, C.Santulli, F.Sarasini, J.Tirillò, A.P.Caruso, M.Infantino, Potential of wool felts in combination with glass fibres: Mechanical and low velocity impact assessment, *Composites Part B*, 118, 158-168, 2017.
- [7] G.Schoeppner, S.Abrate, Delamination threshold loads for low velocity impact on composite laminates, *Composites Part A*, 31, 903–915, 2000.
- [8] M.S.Found, I.C.Howard, Single and multiple impact behavior of a CFRP laminate, *Composite Structures*, 32, 159-163, 1995.
- [9] R.Roy, B.K.Sarkar, N.R.Bose, Impact fatigue of glass fiber–vinylester resin composites, *Composites: Part A*, 32, 871–876, 2001.
- [10] M.V.Hosur, M.R.Karim, S.Jeelani, Experimental investigations on the response of stitched/unstitched woven S2-glass/SC15 epoxy composites under single and repeated low velocity impact loading, *Composite Structures*, 61, 89–102, 2003.
- [11] B.S.Sugun, R.M.V.G.K. Rao, Low-velocity impact characterization of glass, carbon and kevlar composites using repeated drop tests, *Journal of Reinforced Plastic Composite*, 23, 1583–1599, 2004.
- [12] W.A.De Morais, S.N.Monteiro, J.R.M. D’Almeida, Effect of the laminate thickness on the composite strength to repeated low energy impacts, *Composite Structures*, 70, 223–228, 2005.
- [13] J.N.Baucom, M.A.Zikry, A.M.Rajendran, Low-velocity impact damage accumulation in woven S2-glass composite systems, *Composites Science and Technology*, 66, 1229–1238, 2006.
- [14] G.Belingardi, M.P.Cavatorta, D.S.Paolino, Repeated impact response of hand layup and vacuum infusion thick glass reinforced laminates, *International Journal of Impact Engineering*, 35, 609–619, 2008.
- [15] G.Belingardi, M.P.Cavatorta, D.S.Paolino, A new damage index to monitor the range of the penetration process in thick laminates, *Composites Science and Technology*, 68(13), 2646-2652, 2008.
- [16] G.Belingardi, M.P.Cavatorta, D.S.Paolino, On the rate of growth and extent of the steady damage accumulation phase in repeated impact tests, *Composites Science and Technology*, 69, 1693–1698, 2009.
- [17] E.Sevkat, B.Liaw, F.Delale, B.B.Raju, Effect of repeated impacts on the response of plain-woven hybrid composites, *Composites: Part B*, 41, 403–413, 2010.
- [18] M.Ö.Bora, O.Çoban, T.Sinmazçelik, I.Cürgül, V.Günay, On the life time prediction of repeatedly impacted thermoplastic matrix composites, *Mater Des*, 30, 145–153, 2009.
- [19] J.Aurrekoetxea, M.Sarrionandia, M.Mateos, L.Aretxabaleta, Repeated low energy impact behaviour of self-reinforced polypropylene composites, *Polym Testing*, 30, 216–221, 2011.
- [20] M.O.W.Richardson, M.J.Wisheart, Review of low-velocity impact properties of composite materials, *Compos Part A*, 27A,1123, 1996.
- [21] D.M.Biggs, The impact behavior of thermoplastic sheet composite, *J. Reinf. Plast. Compos*, 13, 339–354, 1994.
- [22] A.Kmetty, T.Barany, J.Karger-Kocsis, Self-reinforced polymer materials: A review, *Progress in Polymer Science*, 35(10), 1288-1310, 2010.
- [23] B.Alcock, Single polymer composites based on polypropylene: processing and properties, PhD Thesis, Queen Mary, University of London (UK), 2004.
- [24] N.O.Cabrera, Recyclable all-polypropylene composites: concept, properties and manufacturing, PhD Thesis, Technische Universiteit Eindhoven (Netherlands), 2004.
- [25] N.M.Barkoula, T.Peijs, T.Schimanski, J.Loos, Processing of single polymer composites using the concept of constrained fibers, *Polymer Composites*, 26(1), 114-120, 2005.
- [26] T.Stern, A.Teishev, G.Marom, Composites of polyethylene reinforced with chopped polyethylene fibres: effect of transcrystalline interphase, *Composites Science and Technology*, 57, 1009-1015, 1997.

- [27] A.Pegoretti, M.Ashkar, C.Miglairesi, G.Marom, Relaxation processes in polyethylene fibre-reinforced polyethylene composites, *Composites Science and Technology*, 60, 1181-1189, 2000.
- [28] S.Boria, A.Scattina, G.Belingardi, Experimental evaluation of a fully recyclable thermoplastic composite, *Composite Structures*, 140, 21-35, 2016.
- [29] PURE tape technical data sheet, <https://www.ditweaving.com/pdf/datasheet%20pure%20tape-fabric.pdf> (accessed 19 May 2019)
- [30] PURE sheets technical data sheet, <https://www.ditweaving.com/pdf/datasheet%20pure%20sheet.pdf> (accessed 19 May 2019)
- [31] ASTM D3029. Standard test method for impact resistance of rigid plastic sheeting or parts by means of a tup (Falling Weight). American Society for Testing and Materials, 1982.
- [32] S.Boria, A.Scattina, G.Belingardi, Impact behaviour of a fully thermoplastic composite, *Composite Structures*, 167, 63-75, 2017.
- [33] K.Azouaoui, N.Ouali, Y.Ouroua, A.Mesbah, T.Boukharouba, Damage characterisation of glass/polyester composite plates subjected to low-energy impact fatigue, *J Sound Vib*, 308, 504–513, 2007.
- [34] G.Belingardi, M.P.Cavatorta, D.S.Paolino, Repeated impact behavior and damage progression of glass reinforced plastics, *Fracture of Nano and Engineering Materials and Structures*, 1257-1258, 2006.
- [35] A.R.Shenoy, V.R.Shenoy, Silk soft body armour its history and relevance
- [36] P.V.Cavallaro, Soft body armor: an overview of materials, manufacturing, testing and ballistic impact dynamics, NUWC-NPT Technical Report, 057, 2011.
- [37] H.B.Kocer, Laminated and hybrid soft armor systems for ballistic applications, Thesis, Auburn University, Auburn (Alabama) 2007.
- [38] L.Aretxabaleta, J.Aurrekoetxea, I.Urrutibeascoa, M.Sanchez-Soto, Characterisation of the impact behavior of polymer thermoplastics, *Polymer Testing*, 24, 145-151, 2005.
- [39] M.A.Hassan, S.Haderi, A.R.Bushroa, Low-velocity impact damage of woven fabric composites: Finite element simulation and experimental verification, *Materials and Design*, 53, 706-718, 2014.
- [40] B.Alcock, N.O.Cabrera, N.M.Barkoula, T.Peijs, Low velocity impact performance of recyclable all-polypropylene composites, *Composites Science and Technology*, 66 (11–12), 1724–1737, 2006.
- [41] S.Boria, A.Scattina, Energy absorption capability of laminated plates made of fully thermoplastic composite, Part C: *Journal of Mechanical Engineering Science*, 232 (8), 1389-1401, 2018.
- [42] G.A.Schoeppner, S.Abrate, Delamination threshold loads for low velocity impact on composite laminate, *Composites: Part A*, 31, 903-915, 2000.
- [43] G.Belingardi, R.Vadori, Influence of the laminate thickness in low velocity impact behavior of composite material plate, *Composite Structures*, 61, 27-38, 2003.