

POLITECNICO DI TORINO
Repository ISTITUZIONALE

Studies on propulsion and on-board systems matching in agile project distributed collaborative MDO environment applying for advanced regional and medium haul jet

Original

Studies on propulsion and on-board systems matching in agile project distributed collaborative MDO environment applying for advanced regional and medium haul jet / Fioriti, M.; Boggero, L.; Mirzoyan, A.; Isyanov, A.. - ELETTRONICO. - (2018). (Intervento presentato al convegno 31st Congress of the International Council of the Aeronautical Sciences, ICAS 2018 tenutosi a Belo Horizonte nel 9 - 14 September 2018).

Availability:

This version is available at: 11583/2729897 since: 2019-04-03T11:47:19Z

Publisher:

International Council of the Aeronautical Sciences

Published

DOI:

Terms of use:

This article is made available under terms and conditions as specified in the corresponding bibliographic description in the repository

Publisher copyright

default_conf_editorial [DA NON USARE]

-

(Article begins on next page)



STUDIES ON PROPULSION AND ON-BOARD SYSTEMS MATCHING IN AGILE PROJECT DISTRIBUTED COLLABORATIVE MDO ENVIRONMENT APPLYING FOR ADVANCED REGIONAL AND MEDIUM HAUL JET

M. Fioriti*, L. Boggero**, A. Mirzoyan***, A. Isyanov***,
*Politecnico di Torino, **German Aerospace Center (DLR), ***CIAM

Keywords: *Propulsion and On-board systems matching, More electric aircraft, All electric aircraft, bleedless, power off-takes*

Abstract

The article deals with the evaluation of the influences of the electrification of the aircraft On-Board Systems on Propulsion System performance. In particular, four system architectures have been proposed, each one with a different level of electrification. The influences have been also analysed at aircraft level including a regional and a medium haul reference aircraft. The analysis is carried out using the distributed and collaborative MDAO environment developed in the framework of the AGILE research project. At the end, different behaviours have been observed for the two reference aircraft indicating a different trend in systems matching.

1 Introduction

Matching of Propulsion System (PS) and On-Board Systems (OBS) is having even more importance in aircraft design since the continuous research for a competitive and less costly aircraft [1]. In addition, consideration of new technologies for More Electric Aircraft (MEA) [2], [3] and All Electric Aircraft (AEA) [4] concepts raises the value of the matching of PS and OBS, taking also into account its degree of the electrification. Replacing the hydraulic and pneumatic systems with the equivalent electric ones should increase the ease of OBS monitoring, the integration among them, their efficiency [5], [6] and aircraft safety level [7]. Therefore, the estimation of the engine performance variation due to different OBS architecture is extremely significant. The reduction of the pneumatic power required by the

engine certainly produce beneficial effect on the engine efficiency [8]. At the same time, the necessary increase in mechanical power could reduce the stability margin of engine compressor [5], [9].

Results of the studies on PS and OBS matching applicable for advanced regional and medium haul transport aircraft are presented in the paper. The studies are carried out employing a distributed collaborative MDAO (Multi-Disciplinary Design Analysis and Optimization) environment developed within the Horizon 2020 AGILE project [10], which includes models for the main aerospace disciplines such as aerodynamics, structural, PS, and OBS design. Parameters such as fuel efficiency, system masses and increased aircraft performance are considered as efficiency assessment criteria.

Several studies have been carried out by researchers focusing on different OBS architectures [11], [12] and [13]. All of these show that eliminating the engine bleed air provides several benefits for aircraft and PS. It reduces the aircraft's mass by removing of ducts, valves, heat exchangers and other heavy, maintenance intensive equipment, potential of engine oil contamination of the cabin air supply is eliminated [5]. In this paper, the main focus is the comparison between aircraft with different mission ranges and dimensions. The selection of most suitable electrification level also depends on the aircraft mission time fostering medium and long haul aircraft which achieve greater fuel saving.

In the second section, a brief introduction to the MDAO workflow developed in the framework of H2020 AGILE project is provided. In the third section the aircraft used as test cases

have been described together with the results of the OBS and PS analyses. Finally, in section four the difference between the two aircraft segments has been studied trying to define a possible trend in OBS electrification.

2 Description of the MDAO workflow and design space

In order to analyse the effect of the OBS electrification on the PS performance, it is used the MDAO workflow set up within the AGILE framework. The workflow is depicted in Fig. 1, it describes the disciplines and the partners involved. This workflow is distributed and each competency remains in the partner's computer avoiding intellectual property right issues. The MDAO workflow takes into account for aerostuctural design, PS design, OBS design, nacelle design, aircraft performance simulation, emission and cost analyses.

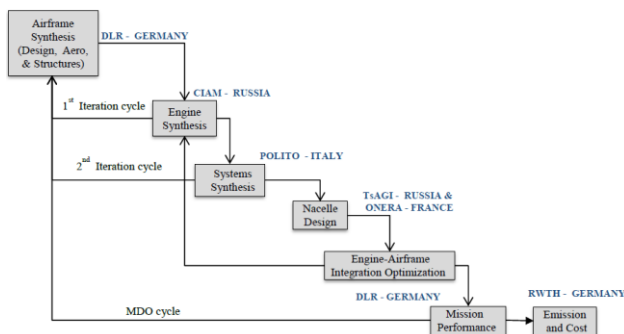

Fig. 1. MDAO workflow developed within AGILE research project.

The disciplinary modules are connected together by means of the common xml-file called CPACS (Common Parametric Aircraft Configuration Schema) developed by DLR [14]. Each disciplinary module is able to read the inputs coming from the other modules and writes its outputs by means of this file. The MDAO starts from the preliminary design of the aircraft, which defines its structure and its aerodynamic performance. For this purpose the tool VAMPzero [15] is supplied with the Top Level Aircraft Requirements (TLARs) calculating the aircraft masses, geometries and aerodynamic coefficients. The engine module calculates the PS performance (i.e. specific fuel consumption SFC, fuel flow FF, engine thrust) and the engine

characteristics in terms of dimensions and mass. This module uses a detailed engine model based on the commercial software GasTurb [16]. The OBS disciplinary module uses ASTRID tool [17] developed by Politecnico di Torino to compute the OBS masses and the systems power requirements. All the main OBS, such as flight control, fuel, environment control, avionics, landing gear, ice protection, electric, pneumatic and hydraulic power generation and distribution systems are individually designed. The nacelle geometry and the quantification of its integration effects on the engine and airframe are carried out with minimization of nacelle drag using specific CFD analyses. The aircraft mission performance is calculated by means of Breguet range equations with the primary objective of quantifying the fuel used by the aircraft to perform the desired mission. All data concerning the masses (e.g. OBS, engine, nacelle and fuel mass) and performance (e.g. OBS power required, PS performance, nacelle integration coefficients) are used by VAMPzero to redefine the preliminary design of the aircraft. The described design loop is reiterated whilst the design is converged. Finally, the aircraft emission and cost are calculated by specific tools [18].

For the purpose of the present study, the workflow has been used to perform converged Multidisciplinary Design Analysis (MDA) in order to understand the effect of the OBS electrification. In particular, a regional jet and a medium haul liner have been studied with the same workflow focusing the analysis on the variation of the engine performance with OBS electrification. With this aim, four different OBS architectures have been defined. Each architecture has a different level of electrification. The first OBS architecture depicted in Fig. 2 is the conventional one with a lowest level of electrification. This architecture is adopted by the greater part of the existing aircraft. In the conventional OBS architecture, the electric, hydraulic and pneumatic power generation and distribution systems are considered. Electric and hydraulic systems transform the engine mechanical power by means of, respectively, electric generators and hydraulic pumps. The pneumatic power is

provided by the bleed air obtained from some engine compressor stages. A bleed system regulates the pressure and the airflow needed by the pneumatic users. In the conventional configuration both the Environmental Control System (ECS) and the Ice Protection System (IPS) for the wings use the compressed air bled from the engine. The electric power supplies the avionics, fuel pumps, IPS (for sensors and other small surfaces) and all furnishing elements such as lights, In-Flight Entertainment (IFE), Galley and Toilet. The hydraulic pumps provide power for Flight Control System (FCS) actuators, landing gear actuators and wheel brakes.

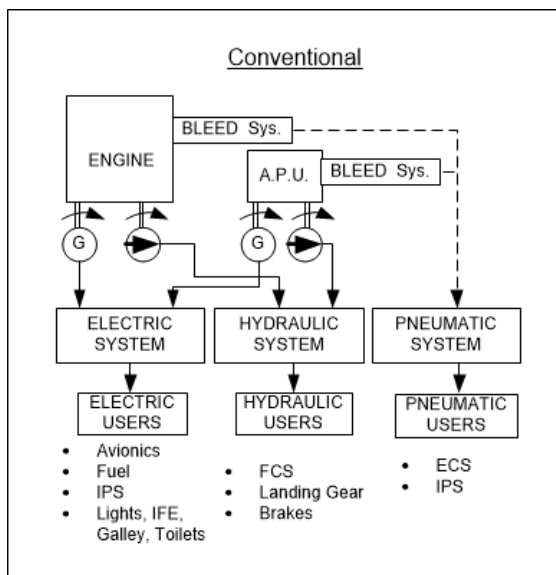

Fig. 2. Conventional OBS architecture.

The MEA 1 architecture is shown in Fig. 3. It represents a first step in OBS electrification. Compared to the Conventional one, all the hydraulic users (i.e. FCS, landing gear actuators, and wheel brakes) are removed and replaced with electric actuators. The Hydraulic Power Generation and Distribution System (HPGDS) is no longer needed and it is removed in favour of a more powerful electric system. The pneumatic power is still provided by engine compressor. Since the removal of the HPGDS, a reduction of OBS total mass is envisaged [19].

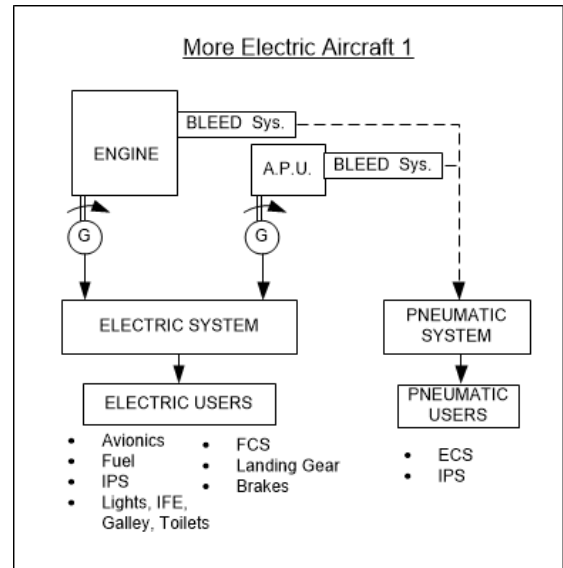

Fig. 3. MEA 1 OBS architecture.

To further increase the OBS electrification level, the MEA 2 architecture is proposed and depicted in Fig. 4. Here, to increase the electrification level, the pneumatic power has been generated using dedicated compressors driven by electric motors. Given that IPS for the wing is totally electrified, the ECS is the only pneumatic user for MEA2 configuration. The HPGDS is also an electric user and it uses the electric driven hydraulic pumps to supply the hydraulic users (i.e. FCS, landing gear actuators and wheel brakes). The electrification of the pneumatic and hydraulic power generation should increase the global efficiency of the OBS systems reducing the power offtakes from the engine.

Finally, the AEA architecture is proposed in Fig. 5. It represents the highest level of electrification for OBS. The engine is bleedless and the pneumatic power is provided by dedicated compressor as for MEA2 configuration. Moreover, the HPGDS is totally removed using electrical actuators for FCS, landing gear actuation and wheel brakes. This is in line with MEA1 architecture. Therefore, the AEA configuration should add the advantages of mass reduction obtained for MEA1 to the advantages of greater efficiency reached in MEA2.

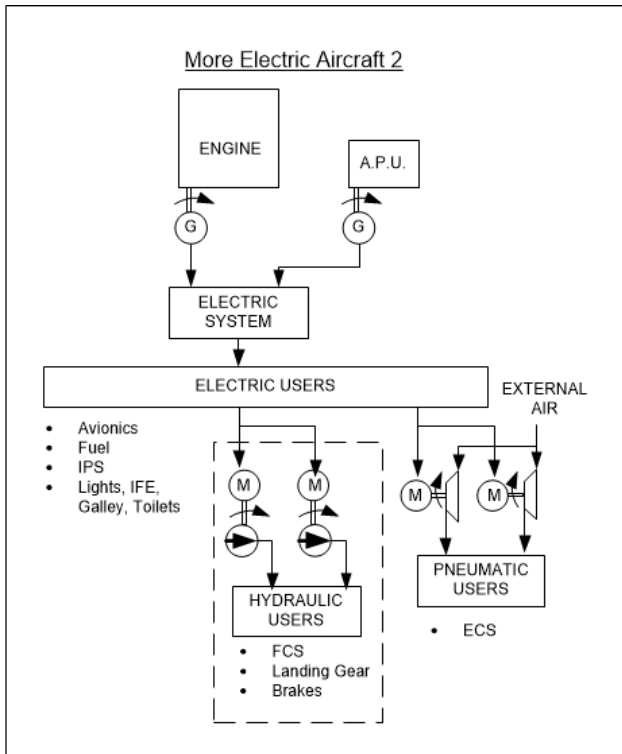

Fig. 4. MEA 2 OBS architecture.

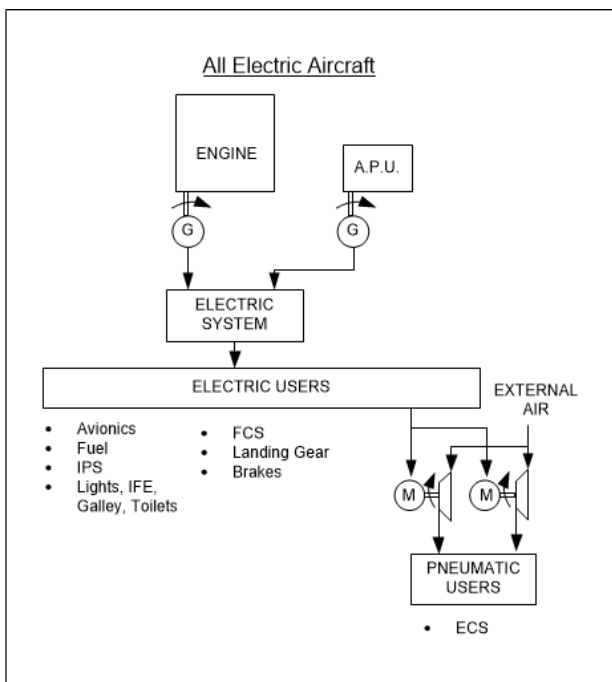

Fig. 5. AEA OBS architecture.

3 OBS and PS analyses

The MDAO workflow has been employed to analyse the effect of the four OBS architectures applied to different aircraft classes, hence,

different PS classes. This can be useful to understand the effect of OBS electrification on PS aiming a perfect matching. The analysis is carried out individuating two reference aircraft corresponding to two different aircraft typical range. The first one is a regional jet developed within the AGILE research project in the same class as Embraer E190. The main specifications are listed in Table 1.

Table 1. Main specifications of reference regional jet.

| Aircraft masses and performance | |
|---------------------------------|----------|
| Range | 3500 km |
| N. passengers | 90 |
| Cruise Mach | 0.78 |
| Payload Mass | 11500 kg |
| Operating Empty Mass | 23965 kg |
| Fuel Mass | 7867 kg |
| Maximum Take-Off Mass | 43332 kg |
| Engine specifications | |
| Maximum Take-Off thrust | 78 kN |
| Engine quantity | 2 |
| Engine by-pass ratio | 12 |

The second reference aircraft is the medium haul, twin engine aircraft like Airbus A320. The well-known specifications have been listed to easy the comparison between the two reference aircraft.

Table 2. Main specifications of reference regional jet.

| Aircraft masses and performance | |
|---------------------------------|----------|
| Range | 6500 km |
| N. passengers | 165 |
| Cruise Mach | 0.78 |
| Operating Empty Mass | 42600 kg |
| Fuel Mass | 18570 kg |
| Maximum Take-Off Mass | 78000 kg |
| Engine specifications | |
| Maximum Take-Off thrust | 110 kN |
| Engine quantity | 2 |
| Engine by-pass ratio | 5.4 |

Both reference aircraft are usually equipped with conventional OBS architecture and with two turbofan. The main differences are in terms of absolute power required by OBS, the engine dimension and thrust, the aircraft flight range and the number of carried passengers.

3.1 OBS and PS results for Regional Jet

The results of OBS design are listed in Table 3 and Table 4 respectively in terms of systems masses and power offtakes. As previously hypothesized, the increase of electrification level leads to a reduction of OBS mass. For MEA1, the removal of the HPGDS and the associated mass reduction is not overlooked by the necessary increment of Electric Power Generation and Distribution System (EPGDS) that should produce and distribute more electric power. The MEA1 represents the lightest architecture considered. Regarding the MEA2 configuration, as can be easily seen in the last line of Table 3, the mass saving obtained removing the heavy pneumatic pipes and heat exchangers of the bleeding system is almost wasted by the additional mass required by the dedicated compressors and by EPGDS growth. Lastly, the AEA architecture is able to gather the advantages of MEA1 and MEA2. However, the necessary increment of EPGDS mass reduces the total mass savings in comparison with MEA1.

Table 3. Mass breakdown for each OBS architecture for Regional Jet

| System Masses [kg] | Conv | MEA1 | MEA2 | AEA |
|---|------|-------|------|-------|
| Avionic | 617 | 617 | 617 | 617 |
| FCS | 572 | 743 | 572 | 743 |
| LG | 1351 | 1392 | 1351 | 1392 |
| ECS and anti-ice | 653 | 653 | 543 | 543 |
| Fuel System | 229 | 229 | 229 | 229 |
| Aux Power System | 158 | 158 | 158 | 158 |
| Furnishing System | 2221 | 2221 | 2221 | 2221 |
| Hydraulic | 512 | 0 | 367 | 0 |
| Electric | 787 | 885 | 1006 | 1040 |
| Total Systems Mass | 7100 | 6898 | 7064 | 6942 |
| Relative variation compared to conv. OBS architecture [%] | - | -2.85 | -0.5 | -2.22 |

Using the OBS design module (i.e. ASTRID tool) the power required by the systems are also computed for each configuration. In Table 4, the power off-takes from each engine are listed in terms of mechanical power required by engine gearbox and bleed air airflow taken from engine compressor in cruise condition (i.e. cruise Mach = 0.78 and cruise altitude = 11 km). They represent the half of the total OBS power required. The difference between conventional OBS architecture and MEA1 is negligible, as for

MEA2 and AEA. The small difference is due to the use of electric actuators instead of the hydraulic ones. The notable difference that can be noticed when comparing conventional and MEA1 with MEA2 and AEA is due to the use of bleedless technology. Using this technology, the bleed air flow is totally cancelled but the mechanical power off-take grows of about 170%.

Table 4. Total power offtakes for each OBS architecture in cruise condition for Regional Jet. All values are per engine.

| OBS architectures | mechanical take [kW] | off-bleed air [kg/s] |
|-------------------|----------------------|----------------------|
| Conventional | 36.4 | 0.398 |
| MEA1 | 35.0 | 0.398 |
| MEA2 | 100.1 | 0 |
| AEA | 98.7 | 0 |

It is now clear the importance of assessing the best PS and OBS matching including the other disciplinary modules introduced in the MDAO workflow. Firstly, the effect on engine performance should be quantified. In particular, one of the most significant effect is the improvement of the engine performance due to reduction of bleed air. Relative change of cruise installed SFC at different bleed air flow rates is depicted in Fig. 6. It is worth noting that reduction of bleed air, in cruise conditions, from 0.4 kg/s up to 0 could improve cruise installed SFC by 3.6%. Using the same engine module, the effect of the mechanical power off-takes is also quantified. The results are shown in Fig. 7 and they reveal that a reduction of cruise power offtake from 100 to 40 kW could improve the installed SFC only by 1.7%.

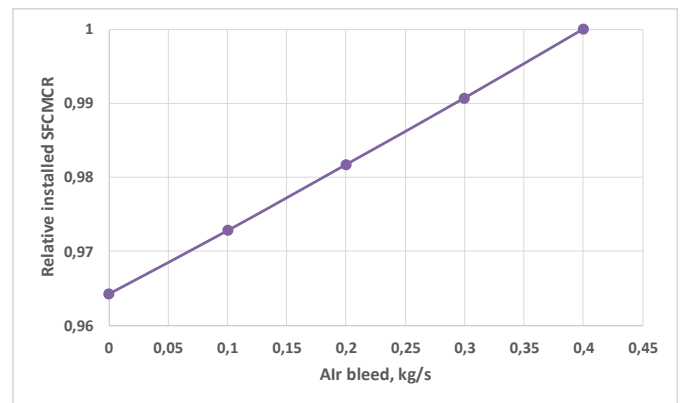

Fig. 6. Influence of bleed air flow rate on relative engine SFC.

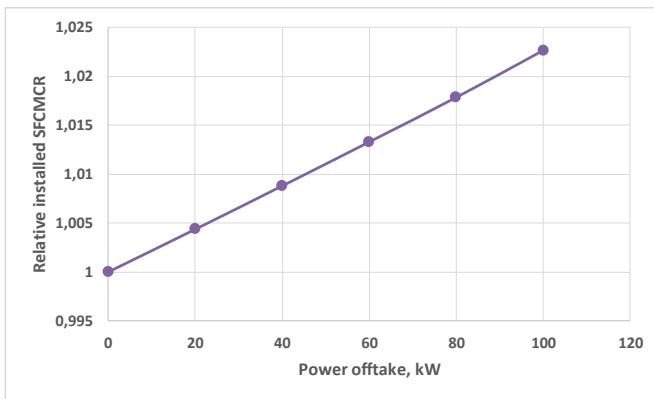

Fig. 7. Influence of mechanical power off-takes on relative engine SFC.

Another influence taken into account in the engine module is the pressure level of the bleed air required by OBS. Particularly, the requirement concerning the minimal value of bleed air pressure, from pneumatic system side, emerged needing two air bleed ports in the engine compressors providing required pressure in all flight conditions. Influence of the minimal air bleed pressure on relative value of the cruise installed SFC is shown in Fig. 8. It is worth noting that the increase of minimal bleed air pressure from 2 to 6 bars could worsen cruise installed SFC of the regional jet by 3%.

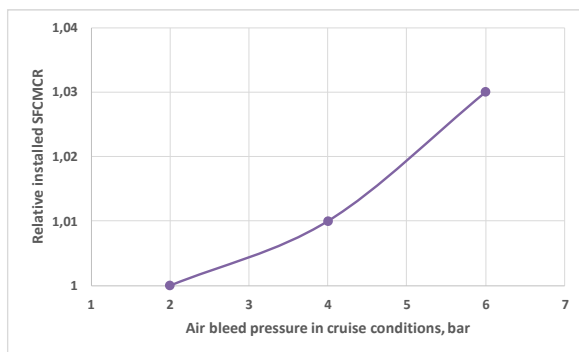

Fig. 8. Influence of minimal air bleed pressure on relative cruise SFC of PS.

Finally, summing up all the influences on PS performance due to OBS electrification and the different total systems mass, it is possible to recalculate the mission performance of the regional reference aircraft. With the aim to have more comparable results, the aircraft Maximum Take-Off Mass (MTOM) and the number of passengers have been kept constant. In this way,

it is possible to compare the SFC of the engine for each OBS configuration maintaining the same engine thrust and dimensions. Therefore, a reduction of SFC and/or a reduction in OBS mass produces an increase of the fuel storable in the aircraft, hence a greater mission range.

The results of the analysis are listed in Table 5. It is worth noting that the MEA1 architecture has the main advantage of reducing its mass, whereas the influence on SFC is negligible. On the contrary, the MEA2 decrease the SFC by 2.28%, however the mass experienced a slight reduction. As speculate before, the AEA significantly reduces both engine SFC and OBS mass extending the aircraft range by 6.63%.

Table 5. Influences of OBS electrification on PS and aircraft mission range compared to conventional configuration applied to Regional aircraft.

| Relative values [%] | MEA1 | MEA2 | AEA |
|---------------------------|-------|--------|--------|
| Mechanical power offtakes | -3.80 | 175.41 | 171.61 |
| Bleed air flow rate | 0 | -100 | -100 |
| OBS mass | -6.95 | -0.99 | -5.53 |
| SFC in cruise condition | -0.02 | -2.28 | -2.30 |
| Fuel mass | 2.82 | 0.40 | 2.25 |
| MTOM | 0 | 0 | 0 |
| Num. of passengers | | 0 | 0 |
| Range | 4.29 | 3.76 | 6.63 |

3.2 OBS and PS results for Medium Haul Aircraft

Using the workflow depicted in Fig. 1 and focusing on the Medium Haul Aircraft, the OBS masses and power off-takes have been calculated and listed respectively in Table 6 and Table 7. Generally, all results are in line with the one obtained for regional reference aircraft. However, a remarkable difference can be observed in Table 6 regarding the total systems mass. For the medium haul liner, the AEA architecture is the lightest one differently from the regional jet where the MEA1 was the lightest. The main contribution for this result is the relatively lower mass growth of the EPGDS. Considering a bigger aircraft, the electric distribution system (i.e. electric cables and load

switching system) is more extended and the use of high voltage reduces significantly its mass [20], [21].

Table 6. Mass breakdown for each OBS architecture for Medium Haul Liner.

| System Masses [kg] | Conv | MEA1 | MEA2 | AEA |
|---|--------------|--------------|--------------|--------------|
| Avionic | 843 | 843 | 843 | 843 |
| FCS | 1077 | 1414 | 1077 | 1414 |
| LG | 3055 | 3147 | 3055 | 3147 |
| ECS and anti-ice | 1197 | 1197 | 996 | 996 |
| Fuel System | 253 | 253 | 253 | 253 |
| Aux Power System | 217 | 217 | 217 | 217 |
| Furnishing System | 5805 | 5805 | 5805 | 5805 |
| Hydraulic | 866 | 0 | 621 | 0 |
| Electric | 1371 | 1440 | 1536 | 1577 |
| Total Systems Mass | 14684 | 14316 | 14402 | 14251 |
| Relative variation compared to conv. OBS architecture [%] | - | -2.51 | -1.92 | -2.95 |

Table 7. Total power offtakes for each OBS architecture in cruise condition for Medium Haul Liner. All values are per engine.

| OBS architectures | mechanical take [kW] | off-bleed air [kg/s] |
|-------------------|----------------------|----------------------|
| Conventional | 56.4 | 0.8 |
| MEA1 | 55.1 | 0.8 |
| MEA2 | 161.7 | 0 |
| AEA | 158.9 | 0 |

As for the regional aircraft, all the influences on PS due to OBS electrification are considered for the analysis of medium haul aircraft. The results of the study are shown in Table 8. They show an increment of aircraft range as a function of the OBS electrification. This result is due to both the reduced OBS mass and the decrease in engine SFC in cruise condition.

Table 8. Influences of OBS electrification on PS and aircraft mission range compared to conventional configuration applied to Medium Haul aircraft.

| Relative values [%] | MEA1 | MEA2 | AEA |
|---------------------------|-------|--------|--------|
| Mechanical power offtakes | -2.27 | 186.74 | 181.65 |
| Bleed air flow rate | 0 | -100 | -100 |
| OBS mass | -2.51 | -1.92 | -2.95 |
| SFC in cruise condition | -0.08 | -3.45 | -3.59 |
| Fuel mass | 1.86 | 1.42 | 2.19 |
| MTOM | 0 | 0 | 0 |
| Num. of passengers | 0 | 0 | 0 |
| Range | 2.86 | 6.31 | 7.69 |

4 Discussion of the results

The main aim of this paper is the analysis of the influences on PS and overall aircraft of the OBS electrification level considering more than one aircraft segment. Focusing on OBS mass and comparing the results for regional and medium haul aircraft, it can be noticed the same trend (see Fig. 9). The removal of the HPGDS is the most important factor to reduce the OBS mass. However, the mass of the HPGDS is more important in smaller aircraft than in bigger one. In the medium haul aircraft, the furnishing and landing gear masses are relatively more significant than the HPGDS one, this reduces the lightening effect of OBS electrification. Moreover, the opposite happens for ECS electrification that is more important for medium haul aircraft since its size is directly related to the number of passengers. Considering also the mass saving in the electrical distribution systems, more extended in bigger aircraft, the most electrified configuration (i.e. AEA) is the lightest.

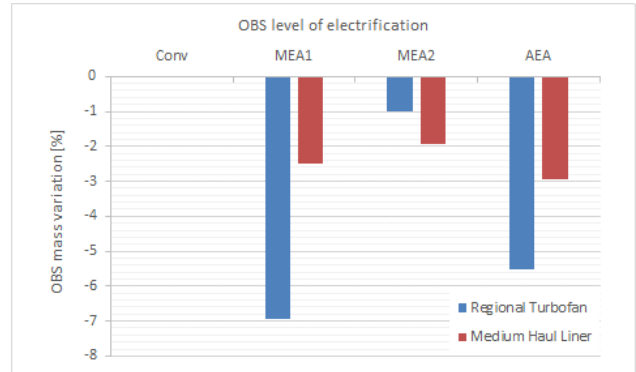

Fig. 9. Effect of OBS electrification on systems mass.

Regarding the influence of the power offtakes on PS SFC, the trend is generally equivalent between the two reference aircraft as shown in Fig. 10. However, a greater SFC improvement can be seen for the medium liner. Electrification of the pneumatic system, i.e. avoiding the use of engine bleed air, increases the efficiency of aircraft carrying more passengers, namely, aircraft using more power for ECS in comparison to the other OBS.

In Fig. 11 is depicted the global influence of the electrification on the whole aircraft by means of

the variation of mission range. It confirms the previous results indicating the AEA architecture as the best option for both reference aircraft. Moreover, the results could indicate a larger performance improvement for larger aircraft. In particular, for small transport aircraft with reduced range, the OBS mass reduction and bleedless technology give equivalent effect on aircraft performance. On the other hand, considering larger aircraft with a more extended range, the increase of engine efficiency due to ECS electrification is more important than the mass contribution.

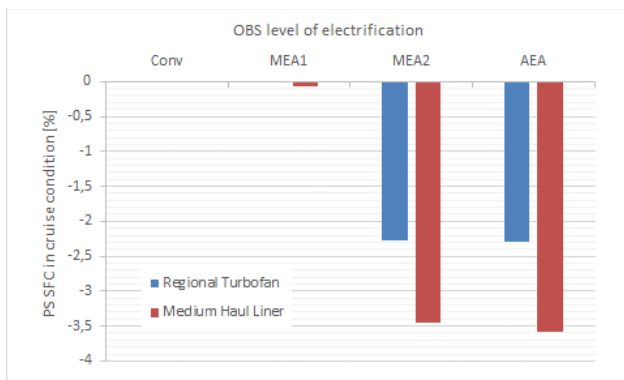

Fig. 10. Influence of OBS electrification on engine SFC.

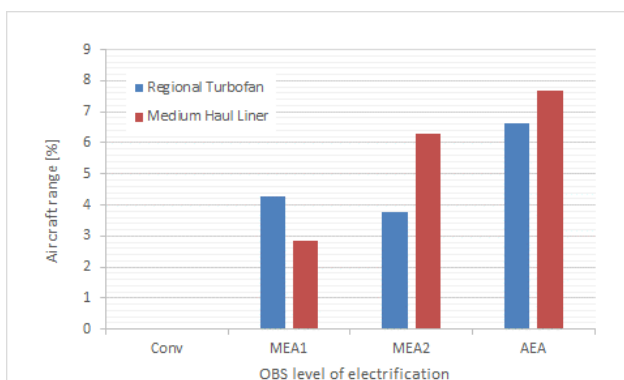

Fig. 11. Influence of OBS electrification on aircraft range.

5 Conclusions

The electrification of the OBS is a trend in every aircraft segments and the present study confirm its validity. To correctly understand the importance of the aircraft electrification is

necessary to perform multidisciplinary analysis including, at least, PS and aircraft mission performance disciplines. It is worth noting that the implementation of such studies in AGILE project distributed collaborative MDAO environment allow to define more accurately the interfaces between all aircraft disciplines taking into account given requirements. Another important outcome is the different results in terms of OBS and PS matching observed when applied to different aircraft segment. The bleedless technology is strongly recommended for medium and probably long haul aircraft (last should be confirmed). Whereas, the removal of the hydraulic systems gives advantages for small aircraft also. A possible trend could be formalized when additional aircraft classes will be analysed giving room to additional researches in this subject.

Acknowledgements

The research presented in this paper has been performed in the framework of the AGILE project (Aircraft 3rd Generation MDO for Innovative Collaboration of Heterogeneous Teams of Experts) and has received funding from the European Union Horizon 2020 Programme (H2020-MG-2014-2015) under grant agreement no 636202.

References

- [1] P. S. Prakasha, L. Boggero, M. Fioriti, B. Aigner, P. D. Ciampa, K. Anisimov, A. Savelyev, A. Mirzoyan and A. Isyanov, "Collaborative System of Systems Multidisciplinary Design Optimization for Civil Aircraft:AGILE EU project," in *18th AIAA/ISSMO Multidisciplinary Analysis and Optimization Conference*, Denver, Colorado (USA), 2017.
- [2] I. Berlowitz, «All/More Electric Aircraft Engine & Airframe Systems Implementation,» in *The 9th Israeli Symposium on Jet Engines and Gas Turbines*, 2010.
- [3] R. I. Jones, «The more electric aircraft—assessing the benefits,» *Proceedings of the Institution of Mechanical Engineers, Part G: Journal of Aerospace Engineering*, vol. 216, n. 5, pp. 259-269, 2002.

- [4] S. Chiesa, S. Farfaglia, M. Fioriti e N. Viola, «Design of all electric secondary power system for future advanced medium altitude long endurance unmanned aerial vehicles,» *Proceedings of the Institution of Mechanical Engineers, Part G: Journal of Aerospace Engineering*, vol. 226, n. 10, pp. 1255-1270, 2012.
- [5] M. J. Cronin, «All-Electric vs Conventional Aircraft: The Production/Operational Aspects,» *Journal of Aircraft*, vol. 20, n. 6, pp. 481-486, 1983.
- [6] D. Scholz, *Aircraft Systems Overview - Greening of Secondary Power Systems*, Brussels, Belgium, 2009.
- [7] S. Chiesa, S. Corpino, M. Fioriti, A. Rougier e N. Viola, «Zonal safety analysis in aircraft conceptual design: Application to SAve aircraft,» *Proceedings of the Institution of Mechanical Engineers, Part G: Journal of Aerospace Engineering*, vol. 227, n. 4, pp. 714-733, 2013.
- [8] M. Sinnet, «787 No-Bleed Systems: Saving Fuel and Enhancing Operational Efficiencies,» *Aero Quarterly QTR_04 / 07*, pp. 06-11, 2007.
- [9] L. Lupelli e T. Geis, A study on the integration of the IP Power Offtake system within the Trent 1000 turbofan engine. Master Thesis., 2012.
- [10] «Agile H2020 Research Project,» [Online]. Available: <https://www.agile-project.eu/>.
- [11] I. Chakraborty e D. N. Mavris, «Integrated Assessment of Aircraft and Novel Subsystem Architectures in Early Design,» *AIAA SciTech*, 2016.
- [12] P. S. Prakasha, P. D. Ciampa, L. Boggero e M. Fioriti, «Assessment of airframe-subsystems synergy on overall aircraft performance in a Collaborative Design,» in *17th AIAA/ISSMO Multidisciplinary Analysis and Optimization Conference*, Washington D.C. (USA), 2016.
- [13] M. Fioriti, L. Boggero, S. Corpino, A. Isyanov, A. Mirzoyan, R. Lombardi e R. D'Ippolito, «Automated Selection of the Optimal On-board Systems Architecture,» in *18th AIAA/ISSMO Multidisciplinary Analysis and Optimization Conference*, Denver (CO), 2017.
- [14] «Official CPACS Webpage,» DLR, Air Transportation Systems, 2016. [Online]. Available: <http://cpacs.de>.
- [15] «VAMPzero - Conceptual Design for the Needs of MDO,» [Online]. Available: <https://software.dlr.de/p/vampzero/home/>. [Consultato il giorno 1 May 2018].
- [16] J. Kurzke, «Gas turbine cycle design methodology: a comparison of parameter variation with numerical optimization,» *Journal of engineering for gas turbines and power*, vol. 121, n. 1, pp. 6-11, 1999.
- [17] S. Chiesa, G. A. Di Meo, M. Fioriti, G. Medici e N. Viola, «ASTRID - Aircraft on board Systems sizing and TRade-off analysis in Initial Design».
- [18] T. Lammering, K. Franz, K. Risse, R. Hoernschemeyer e E. Stumpf, «Aircraft cost model for preliminary design synthesis,» in *50th AIAA Aerospace Sciences Meeting including the New Horizons Forum and Aerospace Exposition*, Nashville, Tennessee, 2012.
- [19] D. van den Bossche, «The A380 flight control electrohydrostatic actuators, achievements and lessons learnt,» in *ICAS*, Hamburg, 2006.
- [20] A. Abdel-Hafez, Power Generation and Distribution System for a More Electric Aircraft - A review, Dr. Ramesh Agarwal, ISBN: 978-953-51-0150-5, Intech, 2012, pp. 289-308.
- [21] C. R. Avery, S. G. Burrow and P. H. Mellor, "Electrical generation and distribution for the more electric aircraft," University of Bristol, 2007.

Copyright Statement

The authors confirm that they, and/or their company or organization, hold copyright on all of the original material included in this paper. The authors also confirm that they have obtained permission, from the copyright holder of any third party material included in this paper, to publish it as part of their paper. The authors confirm that they give permission, or have obtained permission from the copyright holder of this paper, for the publication and distribution of this paper as part of the ICAS proceedings or as individual off-prints from the proceedings.