

Overview on Optical Fronthauling Technologies for Fixed-Mobile Convergence

*Original*

Overview on Optical Fronthauling Technologies for Fixed-Mobile Convergence / Gaudino, Roberto - In: 5G Italy White eBook: from Research to MarketSTAMPA. - [s.l.] : CNIT, 2018. - ISBN 9788832170009. - pp. 99-108

*Availability:*

This version is available at: 11583/2728555 since: 2019-03-15T18:23:18Z

*Publisher:*

CNIT

*Published*

DOI:

*Terms of use:*

This article is made available under terms and conditions as specified in the corresponding bibliographic description in the repository

*Publisher copyright*

(Article begins on next page)

# Overview on Optical Fronthauling Technologies for Fixed-Mobile Convergence

Roberto Gaudino

**Abstract** We present in this Chapter an overview of optical fronthauling technologies for fixed-mobile convergence in next generation 5G access networks. The Chapter first introduces the general concept of Cloud Radio Access Network, or C-RAN, then it presents the most common proposals for fronthauling, based on Digitized Radio-over-Fiber, or D-RoF, according to the CPRI or OBSAI standards. The Chapter then prosecutes by presenting the very recent evolutions of D-RoF toward the "functional split" paradigm, as already available in the latest releases of the CPRI specifications. Finally, some recent research trends towards Analog RoF are presented. The Chapter is intentionally written in a tutorial way, to be used by newcomers in this field. It anyway also reports a vast set of bibliographic references to guide the interested reader toward more detailed technical presentations.

## 1 Introduction and scope of this Chapter

In modern mobile access network (4G and in the forthcoming 5G), telco operators are trying to reduce their network CAPEX and OPEX implementing the new paradigm usually indicated as Cloud- (or Centralized-) Radio Access Network (C-RAN). In a broad sense, C-RAN is an architecture in which several physical and network layer functions that were previously implemented in base-stations (BS) are moved (and thus centralized) to Central Offices (CO). Advantages of this approach are described in many recent papers, such as [1], and can be summarized as follows:

- Reduction of the complexity of the antenna-site hardware and software. In particular, the antenna site installation is potentially simplified, footprint is lower and the maintenance costs are largely reduced.

---

Roberto Gaudino

Politecnico di Torino, Dipartimento di Elettronica e Telecomunicazioni (DET), Corso Duca degli Abruzzi, 24, 10129 Torino, Italy, e-mail: roberto.gaudino@polito.it

- Better energy efficiency: centralization and function virtualization allow to dynamically allocate centralized processing capabilities, and depending on traffic requirements, processing can be turned to low power or even be shut down selectively, thanks to the usual advantages arising from resources statistically multiplexing.
- Multi-point cooperation techniques proposed for 5G can be much more efficiently implemented thanks to the centralized processing of physical and network layer functions for several antenna sites.

The C-RAN paradigm requires anyway much larger transfer of information from the CO to the antenna sites compared to previous solutions based on back-hauling, thus requiring dedicated high-capacity links in the fixed access networks that has to support the mobile network. The techniques used to implement these links in C-RAN is usually indicated as "fronthauling", and typically requires a fixed access networks based on optical fibers. The trend is often indicated as "fixed-mobile convergence", and it is enabled by a joint design of the fiber-based fixed access network and the mobile network.

Scope of this Chapter is to give an introductory overview of current trends in optical fronthauling. The Chapter is intentionally written in a tutorial way, and it is thus meant for people that are new in the sector of optical fronthauling and who wants to have a first insight. After reading this Chapter, the interested reader can find much more detailed technical information in the large list of papers reported in the Bibliography [1]-[24].

The Chapter is thus organized as follows. We start by presenting in the rest of this Section some preliminary concepts on fronthauling, then we focus in the following Sections on the different fronthauling techniques that are currently implemented or under investigation, and in particular:

- Digitized Radio-over-Fiber (D-RoF), based on the CPRI [6] or OBSAI [7] de-facto standards.
- The "network level" trends, based on the so-called "functional split" approach, following the recently released e-CPRI [8] specifications.
- Alternative solutions based on Analog Radio-over-Fiber (A-RoF) or DSP-assisted equivalents of A-RoF

In order to have a common terminology, we introduce here some of the basic definitions and acronyms following the conventions used, for instance, in [1], [2] and [3], also reporting them in Fig. 1, which shows a schematic comparison between traditional architectures based on backhauling and the new C-RAN+fronthauling architectures. The key elements of the C-RAN+fronthauling architecture are:

- the remote radio head (RRH) is the part of the hardware and software functions that remains in the antenna site. The C-RAN target is to leave in the RRH only the radio frequency (RF) part and a very lean protocol for interfacing it to the fronthauling link.
- most of the baseband digital signal processing functions that are usually present in the "traditional" base station architecture are moved to Base-Band processing Units (BBU) at the CO.

- in "true" Cloud RAN, BBU are organized in a shared BBU pool in (one or more) central offices, to allow virtualisation of the functions and to take advantage of statistical multiplexing arising from the centralization of the services for many BBUs.

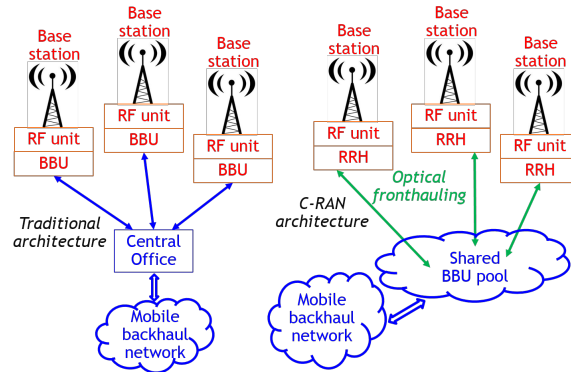

Fig. 1 Comparison with traditional and C-RAN architectures for mobile networks.

## 2 Fronthauling based on Digitized Radio-over-Fiber D-RoF

The most common fronthauling solution, that has already reached commercial level implementation, is based on the Digitized Radio-over-Fiber (D-RoF) approach. Here we will report its main features, while the interesting reader can find more details in the Specification of one of the two available de-facto standards written by two different industry consortia, called CPRI [6] (Common Public Radio Interface) and OBSAI [7] (Open Base Station Architecture Initiative). In Fig. 2 we present some simplified schematics that try to point out the main differences between traditional architectures (which we will simply indicated as "backhauling") and new DRoF fronthauling. The top left graph shows the traditional backhauling architecture, where the link between the base station and the CO basically carries the same packets that flows on the wireless part (plus obviously some additional control and management information). The top right graphs zooms on the RF and BBU parts, while the bottom graph shows the DRoF fronthauling architecture. The basic principle of D-RoF is transporting over the fronthauling fiber links the "native" radio signal, such as in analog radio-over-fiber, but using a digitized approach of the baseband version of the signal. In particular, as schematized in Fig. 2 and following for instance the upstream direction:

- the radio signal received from the antenna is processed in the RRH by RF I/Q demodulation hardware, down-converting it to two I- and Q- baseband signals.

For what we need to discuss later on, it is worth noting that if the RF signal occupies a bandwidth  $B$  in the wireless spectrum, the two I- and Q- baseband signals occupies a (one-sided) bandwidth  $B/2$  each.

- the two baseband signals are digitized by a pair of analog-to-digital converters (ADC), generating a digital stream at their output. If the number of bits of the ADC is  $n_{bit}$  and the ADC sampling rate is  $f_s$ , the resulting bit rate at the output of one ADC is  $n_{bit} \cdot f_s$ , so that the total resulting bit rate to be transported on the fronthauling link is  $2n_{bit} \cdot f_s$ , where for the sampling theorem  $f_s > B$ .
- a very lean protocol (such as CPRI or OBSAI) then adds the required control and framing information to this digital stream (thus further increasing the bit rate), then sent it using a suitable optical fiber transport system to the central office, where it is optically received, processed and sent to the aforementioned BBU.
- overall, as again shown in Fig. 2, the BB functions are completely moved from the antenna site to the CO, thus allowing to fully implement the C-RAN paradigm.

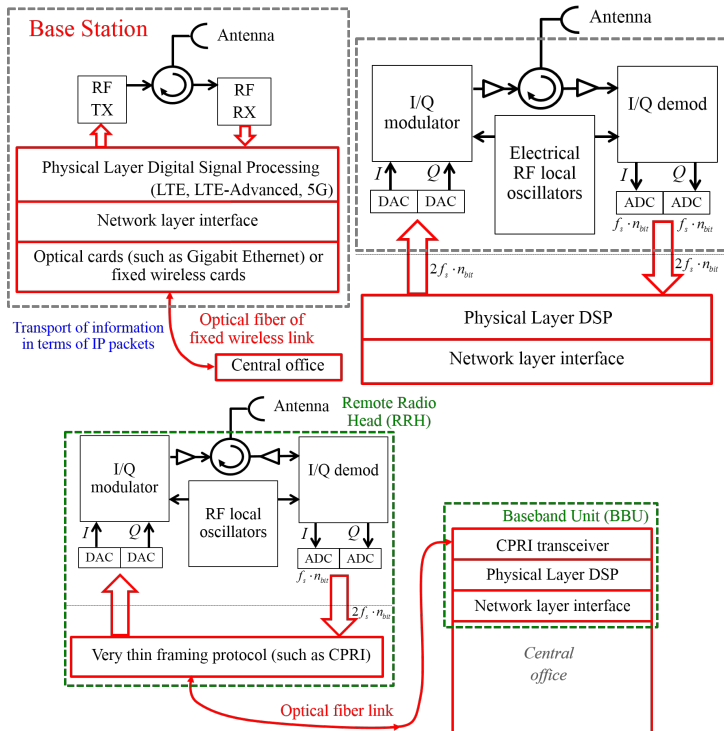

**Fig. 2** Comparison between traditional backhauling and new DRoF fronthauling: simplified schematics. Top left: traditional backhauling architecture. Top right: zooming in the RF and BBU parts of the traditional architecture. Bottom: DRoF fronthauling architecture

Compared to the traditional backhauling architecture, the DRoF one poses anyway two main constraints on the fronthauling link: bit rate to be transported and latency.

Starting from the first issue, let's consider, as already mentioned, that for a bandwidth  $B$  of a give radio waveform in the wireless spectrum, a bit rate (at least) equal to  $2n_{bit} \cdot f_s$  (plus control information) should be carried on the fronthauling link, and for the sampling theorem  $f_s > B$ , so that the resulting bit rate must be greater than  $2n_{bit} \cdot B$ . As a more practical example, for  $B = 20$  MHz on the wireless channel, the CPRI protocol [6] assumes that the DAC/ADC runs at  $f_s = 30.72$  Msamples/s and  $n_{bit} = 16$  and thus the net bit rate to be transported is 983 Mbit/s. On top of this, CPRI add some control and management information, and the 8B/10B line code, resulting in a gross bit rate to be transported of 1.228 Gbit/s (CPRI line bit rate option 2). Considering that on a  $B = 20$  MHz wireless bandwidth the net bit rate is often less than 100 Mbit/s, it is evident that DRoF fronthauling faces the so-called "bandwidth expansion" issue, i.e., it requires transporting a bit rate that is, as a rule of thumb, at least 10 times bigger than the net bit rate of the radio part, and thus also (again as a rule of thumb) 10 times bigger than for the traditional backhauling architecture.

The bit rate we have estimated is for the fronthauling transport of one single radio waveform, so that in practice for a given fronthauling link supporting one RRH it should be multiplied by:

- the number of segments of the antenna site (typically at least three).
- if carrier aggregation is used, the number of radio carriers used by the antenna site.
- if MIMO techniques are used, the multiplicity of the implemented  $N \times N$  MIMO.

The resulting high bit rates thus obviously require a fiber-based solution for the fronthauling link. Using today optical access solutions, the fronthauling bit rates are typically not critical for 4G LTE networks, where typical parameters are  $B = 5$  or 10 MHz (or less), 3 segments and limited or no MIMO. In many currently installed implementations for 4G, the optical links thus runs at about 10 Gbit/s (CPRI line bit rate option 7) or less. The latest version of the CPRI specs introduced CPRI line bit rate option 10, having a bit rate equal to 24.33 Gbit/s (thus able for instance to transport in parallel 24 radio waveforms of the type presented in the aforementioned example with  $B = 20$  MHz). Anyway, the required bit rate may become extremely critical for LTE-Advanced and even more for 5G, which in some implementations will use much larger radio bands  $B$ , massive MIMO and extensive carrier aggregation. This is actually the main reason why fronthauling solutions have recently evolved in the directions described in the following Sect. 3, which requires much lower bit rates, or in Sect. 4, which follow an analog radio-over-fiber approach. Some research papers have also tried to address the issue of using digital compression techniques directly to the bit stream at the output of CPRI, such as [9], which demonstrates a bit rate compression by a factor of two, and [10] showing a compression by a factor of about four, at the expense of higher DSP complexity.

Another very important issue in fronthauling compared to traditional backhauling is that the end-to-end latency should be kept very small. The actual requirements are strongly dependent on the physical layer specification of the radio part, but it is evident that while in traditional backhauling architecture the processing is inside

each base station, and thus the latency is a "local" issue inside each given radio cell, in C-RAN with DRoF fronthauling the round-trip latency is actually the sum of the two parts due to the wireless and the optical segments. The interested reader can find detailed information in [2], [4]. Here we just want to point out that the actual round-trip latency constraints often require that the fronthauling segment has a total round-trip latency below  $200 \mu\text{s}$ , which should include all processing (such as CPRI) and propagation (fixed or variable) delays. This tight latency requirement for fronthauling has several consequences:

- the optical physical layer that supports fronthauling should be kept simple to avoid adding an additional term to the latency budget. In fact, many practical CPRI implementation uses pure optical On-Off Keying (OOK) and direct detection, usually without forward error correcting codes (FEC).
- if DRoF digital stream is to be carried on a packet-switched optical access solutions, then the variable delay that is intrinsic in a multiple access shared environment should be kept under strict control. This is for instance very important for DRoF over Passive Optical Networks (PON) or in general for any switched Ethernet transport. A very vast and recent literature is available on this topic, such as [11] and [12]
- ultimately, the fiber propagation delay limits the maximum geographical extension of a given C-RAN domain. As an example, a 10 km distance between RRH and CO accounts for about  $100 \mu\text{s}$  round-trip delay due to fiber propagation alone.

### 3 Alternative solution based on the functional split approach

As outlined in the previous Section, the CPRI (or OBSAI) DRoF enables the full implementation of the C-RAN paradigm, at the expense anyway of very high bit rate requirements on the optical links. Particularly for future 5G millimeter-wave bands, which may use several hundred MHz radio bands and massive MIMO, the "pure" CPRI approach becomes unsustainable. As a consequence, several new options have been proposed mostly in order to greatly reduce the required bit rate on the fronthauling link. The most promising one is likely the "functional split" paradigm, a solution that has already been specified by the CPRI industry cooperation under the acronym eCPRI. While the details of the implementation can be found in [8], we report here only its key principle, that is based on considering that, rather than moving the *full* baseband protocol stack from the RRH to the BBUs, one can envision moving only a part of it, by properly splitting the functions that should remain in the RRH, and those that are moved to the BBUs (from which the definition of "functional split"). In particular, eCPRI decomposes the baseband protocol stack into the following layers (using the E-UTRA terminology and starting from the higher layer and going down to the physical layer):

- Radio Resource Control (RRC)
- Packet Data Convergence Protocol (PDCP)

- Radio Link Control (RLC)
- Medium Access Control (MAC)
- Physical (PHY) which is the lower layer that is relevant for C-RAN and that directly interfaces to the Radio Functions layer (RF)

The eCPRI recommendation indicates five possible functional splits (labelled as "Split A" to "Split E") that are logically placed "below" any of the aforementioned layers. For instance, "Split E" is logically implemented below the PHY layer and coincides with the CPRI approach described in the previous section, in which virtually the full stack is moved in the centralized BBU, while for instance "Split C" leaves the PHY and MAC function in the RRH and moves only the RLC, PDPC and RRC layers in the centralized BBUs. The higher the split is placed, the smaller is the bit rate to be transported. An interesting example is given in [13]: for a situation in which Split E requires 9.83 Gbit/s, Split D requires 2.68 Gbit/s and Split C requires 468 Mbit/s. The availability of different levels of splitting thus allows the network designer a trade-off between fronthauling bit rate and the level of C-RAN actual centralization of functions.

#### **4 Alternative solutions based on variants of Analog Radio-over-Fiber**

While the functional split paradigm tackles the DRoF bandwidth expansion problem with a "network layer" approach, other solutions have been proposed at the research level focusing only on the physical layer, using variants of analog radio-over-fiber (A-RoF) technologies [14],[15] in which the radio waveform is directly carried on the fiber in analog way according to one of the following principles:

- direct transmission on the fiber of the radio waveform at its original RF frequency, without any down-conversion (sometimes indicated as "RF-over-Fiber" [15]). This the most traditional analog radio over fiber approach, and it has been commercially used for antenna remoting or distributed antenna systems (DAS) in the so-called "Microwave Applications" [17].
- transmission on the fiber of a down-converted version of the radio waveform at an intermediate frequency, sometimes indicated as "IF-over-Fiber" [15]. This approach is usually preferred to RF-over-Fiber when the goal is the aggregation of many radio waveforms on the same fiber using Frequency Division Multiplexing (FDM) [18].
- more exotic solutions, such as those based on delta-sigma analog-to-digital conversion, [16] which are anyway for the moment only limited to research level.

Of the three approaches presented in this section, the one originally proposed in [18] seems particularly suitable for the requirement of next-generation fronthauling for 5G. It is an IF-over-Fiber approach that allows multiplexing a high number of radio channels using a digital signal processing (DSP) and FDM aggregation, and it is often indicated as DSP-assisted A-RoF. The key idea is that, using a proper DSP



setup that uses some of the properties of FFT/IFFT algorithms, a very large number of baseband radio waveforms can be multiplexed with a single FFT/IFFT operation on very tightly packed comb of intermediate frequencies. For instance, the original paper [18] experimentally showed a DSP-assisted FDM aggregation of 48 20-MHz LTE radio waveforms using only 1.5 GHz analog bandwidth on the fiber, while the CPRI approach would have required an aggregated data rate of 59 Gb/s.

Our group has worked in the same area, demonstrating:

- the extension of the capacity of these systems up to 384 20-MHz LTE radio waveforms on the same fiber [19].
- the possibility to carry these signals also on Passive Optical Network (PON) architectures [20], which are intrinsically very demanding in terms of end-to-end attenuation of the optical link.
- the adaptation to the specific requirements of upstream transmission [21].

## 5 Discussion on the relation with optical access networks and conclusion

We discuss here, as a conclusion, the relation fronthauling and the existing optical access technologies, also because this is an area that is currently (2018) going through an enormous revolution. In fact, in most of the developed countries, and in particular in Europe, fixed access networks are undergoing an epochal transition from the previous "all-copper" (twisted pairs+ADSL) situation to the new Fiber-To-The-Home (FTTH) paradigm, as also requested by one of the pillars of the H2020 EU Digital Agenda. As of 2018, and focusing on Italy as an example, the major telco operators are massively deploying either FTTH or intermediate solutions, such as Fiber-to-the-Cab (FTTCab) or Fiber-to-the-Building (FTTB), typically on a market competitive business model in the large and denser cities, and on public incentives for smaller cities and rural areas.

FTTH deployment for residential users are typically based on PON i.e. on optical-splitter based point-to-multipoint architectures, while FTTCab is more likely implemented using dedicated point-to-point (P2P) fibers. The fronthauling solutions presented in this Chapter, and particularly CPRI DRoF, are today usually deployed using P2P dedicated fibers, since in this case basically no sharing issues should be handled at the network layer, and at the physical layers the optical loss is low, making the transceivers particularly simple and thus low cost. Anyway, the massive deployment of FTTH is making geographically widespread PON access more and more common, at least in urban areas. A very vast scientific literature is thus focused on enabling efficient fronthauling over PON [11], [12], [18], [19], [20], [21], [22], [23]. Here, two main technical issues should be solved:

- at the optical physical layer, PON are characterized by a high insertion loss (above 29 dB), mostly due to the presence of optical splitters in the link. The solutions presented in Sect. 4 are particularly sensitive to high insertion loss, since they use

"analog" transmission technologies. Anyway, by a careful design of the link, many demonstrations of A-RoF over PON have been demonstrated in the literature [18], [19].

- at the network layer, PON is intrinsically a shared solution and thus requires multiplexing. The currently most deployed standard (ITU-T G-PON) use Time Division Multiple Access (TDMA) in both directions and a Dynamic Bandwidth Allocation (DBA) algorithm [24] for sharing resources among the (up to 64) PON users. All the following PON standards that have followed G-PON still uses some form of TDMA. The use of DRoF (such as CPRI) over PON thus poses stringent latency requirements. In fact, while the original CPRI idea was based on a dedicated circuit-switched point-to-point solution, its application over PON should intrinsically handle the latency variation typical of a packet-switched architecture. Again, a very vast literature is available on this topic, with several proposed solutions [11], [12].

We have tried to give in this Chapter an overview of different possible solutions for optical fronthauling, presenting a tutorial on its main implementation aspects. A vast literature exists also on the related techno-economics [22], [23].

**Acknowledgements** The work presented in this Chapter was supported by the POLITO PhotoNext Center ([www.photonext.polito.it](http://www.photonext.polito.it)). The author would like to thank his collaborators Pablo Torres Ferrera and Mengesha Befekadu Debebe.

## References

1. J. Wu, Z. Zhang, Y. Hong and Y. Wen, "Cloud radio access network (C-RAN): a primer," *IEEE Network*, vol. 29, no. 1, pp. 35-41, Jan.-Feb. 2015.
2. A. Pizzinat, P. Chanclou, F. Saliou and T. Diallo, "Things You Should Know About Fronthaul," *IEEE/OSA Journal of Lightwave Technology (JLT)*, vol. 33, no. 5, pp. 1077-1083, March 2015.
3. A. Checko et al., "Cloud RAN for Mobile Networks – A Technology Overview," *IEEE Communications Surveys & Tutorials*, vol. 17, no. 1, pp. 405-426, 2015.
4. M. Agiwal, A. Roy and N. Saxena, "Next Generation 5G Wireless Networks: A Comprehensive Survey," *IEEE Communications Surveys & Tutorials*, vol. 18, no. 3, pp. 1617-1655, 2016.
5. T. Pfeiffer, "Next generation mobile fronthaul and midhaul architectures," *IEEE/OSA Journal of Optical Communications and Networking*, vol. 7, no. 11, pp. B38-B45, 1 November 2015.
6. Official public web page for CPRI specification <http://www.cpri.info/spec.html>
7. Official public web page for OBSAI specification <http://www.obsai.com/specifications.htm>
8. Official public web page for e-CPRI specification [http://www.cpri.info/downloads/eCPRI\\_v\\_1\\_2\\_2018\\_06\\_25.pdf](http://www.cpri.info/downloads/eCPRI_v_1_2_2018_06_25.pdf)
9. B. Guo, W. Cao, A. Tao and D. Samardzija, "LTE/LTE-A signal compression on the CPRI interface," *Bell Labs Technical Journal*, vol. 18, no. 2, pp. 117-133, Sept. 2013.
10. H. Si, B. L. Ng, M. S. Rahman and J. Zhang, "A Novel and Efficient Vector Quantization Based CPRI Compression Algorithm," *IEEE Transactions on Vehicular Technology*, vol. 66, no. 8, pp. 7061-7071, Aug. 2017.
11. D. Chitimalla, K. Kondepu, L. Valcarengi, M. Tornatore and B. Mukherjee, "5G fronthaul-latency and jitter studies of CPRI over Ethernet," *IEEE/OSA Journal of Optical Communications and Networking (JOCN)*, vol. 9, no. 2, pp. 172-182, Feb. 2017.

12. L. Valcarenghi, K. Kondepu and P. Castoldi, "Time-versus size-based CPRI in ethernet encapsulation for next generation reconfigurable fronthaul," *IEEE/OSA Journal of Optical Communications and Networking (JOCN)*, vol. 9, no. 9, pp. D64-D73, Sept. 2017.
13. R. Knopp, "Overview of Functional Splits in OAI" [https://www.openairinterface.org/docs/workshop/5\\_OAI\\_Workshop\\_20180620/KNOPP\\_OAI-functional-splits.pdf](https://www.openairinterface.org/docs/workshop/5_OAI_Workshop_20180620/KNOPP_OAI-functional-splits.pdf)
14. J. Beas, G. Castanon, I. Aldaya, A. Aragon-Zavala and G. Campuzano, "Millimeter-Wave Frequency Radio over Fiber Systems: A Survey," *IEEE Communications Surveys & Tutorials*, vol. 15, no. 4, pp. 1593-1619.
15. C. Lim et al., "Fiber-Wireless Networks and Subsystem Technologies," *IEEE/OSA Journal of Lightwave Technology*, vol. 28, no. 4, pp. 390-405, Feb.15, 2010.
16. J. Wang et al., "Digital mobile fronthaul based on delta-sigma modulation for 32 LTE carrier aggregation and FBMC signals," *IEEE/OSA Journal of Optical Communications and Networking*, vol. 9, no. 2, pp. A233-A244, 2017.
17. J. Yao, "Microwave Photonics," *IEEE/OSA Journal of Lightwave Technology*, vol. 27, no. 3, pp. 314-335, Feb.1, 2009.
18. X. Liu, H. Zeng, N. Chand and F. Effenberger, "Efficient Mobile Fronthaul via DSP-Based Channel Aggregation," *IEEE/OSA Journal of Lightwave Technology*, vol. 34, no. 6, pp. 1556-1564, 2015.
19. M. Befekadu, S. Straullu, S. Abrate and R. Gaudino, "Experimental Optimization of DSP-Aggregated Front-hauling Transmission for up to 4x96 LTE radio waveforms," 42nd European Conference on Optical Communication, ECOC 2016; Dusseldorf, Germany, 2016.
20. S. Straullu, M. Befekadu, S. Abrate and R. Gaudino, "Optimization of DSP-based channel aggregation parameters for front-hauling over PON infrastructure," 2016 IEEE Photonics Conference (IPC), Waikoloa, HI, 2016.
21. P. Torres-Ferrera, S. Straullu, S. Abrate and R. Gaudino, "Upstream and downstream analysis of an optical fronthaul system based on DSP-assisted channel aggregation," *IEEE/OSA Journal of Optical Communications and Networking (JOCN)*, vol. 9, no. 12, pp. 1191-1201, Dec. 2017.
22. A. Udalcovs *et al.*, "An Insight into the Total Cost of Ownership of 5G Fronthauling," 2018 20th International Conference on Transparent Optical Networks (ICTON), Bucharest, 2018.
23. G. Arevalo, R. Hincapie, R. Gaudino, "Optimization of multiple PON deployment costs and comparison between GPON, XGPON, NGPON2 and UDWDM PON", *Elsevier Optical Switching and Networking*, vol. 25, pp. 80-90, 2017.
24. ITU-T G.983.4 Recommendation, "A broadband optical access system with increased service capability using dynamic bandwidth assignment.