

Waste heat recovery utilized for an Organic Rankine Cycle in a steel hot-forging industry

Original

Waste heat recovery utilized for an Organic Rankine Cycle in a steel hot-forging industry / Nuccio, Patrizio; De Meo, Fabio. - In: IOP CONFERENCE SERIES. EARTH AND ENVIRONMENTAL SCIENCE. - ISSN 1755-1315. - STAMPA. - 221:(2019). (Intervento presentato al convegno World Multidisciplinary Earth Sciences Symposium (WMESS 2018) tenutosi a Prague, Czech Republic nel 3 - 7 September 2018) [10.1088/1755-1315/221/1/012132].

Availability:

This version is available at: 11583/2715478 since: 2018-10-22T09:55:54Z

Publisher:

IOP

Published

DOI:10.1088/1755-1315/221/1/012132

Terms of use:

This article is made available under terms and conditions as specified in the corresponding bibliographic description in the repository

Publisher copyright

(Article begins on next page)

PAPER • OPEN ACCESS

Waste Heat Recovery Utilized for an Organic Rankine Cycle in a Steel Hot-Forging Industry

To cite this article: Patrizio Nuccio and Fabio De Meo 2019 *IOP Conf. Ser.: Earth Environ. Sci.* **221** 012132

View the [article online](#) for updates and enhancements.



IOP | ebooks™

Bringing you innovative digital publishing with leading voices to create your essential collection of books in STEM research.

Start exploring the collection - download the first chapter of every title for free.

Waste Heat Recovery Utilized for an Organic Rankine Cycle in a Steel Hot-Forging Industry

Patrizio Nuccio¹, Fabio De Meo¹

¹ Politecnico di Torino, Department of Energy, C.se Duca degli Abruzzi 24, Turin, Italy

patrizio.nuccio@polito.it

Abstract. Waste heat recovery in industrial activities is virtually an “energy saving method” which can be introduced into a productive system with successful results as far as technical, economic and environmental aspects are concerned. It is now in fact evident that a careful heat waste management leads not only to primary energy savings, but also to a reduction in greenhouse gas emissions, often with economic sustainability. The case presented here refers to a steel hot-forging industry situated in the Nord-west of Italy that is equipped with steel hot processing devices, and, in particular, with methane ovens for the hot cutting machines. Therefore, the objective of the present work was to carry out a project aimed at the recovery of the hot flows exiting from the ovens in order to produce electric and thermal power that could be used in the same industrial activity or in tertiary activities near the factory itself. After an in-depth analysis in this technological activity inside the factory concerning the electricity and natural gas consumption and hot gas flow-rate availability, different power plant solutions were considered and evaluated. At the end of the analysis process, the choice fell upon an Organic Rankine Cycle with a power of 50 [kW_{el}]. The technical and economic analysis of this powerplant furnished a pay-back period between the 17th and the 18th year, as far as electrical energy is concerned, which was considered excessively long. An acceptable payback period, that is, of less than ten years, was instead found for the recovery of the thermal power of the ORC plant, which could be utilized, through a remote heating system, for public buildings, such as elementary/primary schools and the City Hall, which are located very close to the factory. In short, with this plant solution, it will be possible to produce more than 150 MWh/year of electric energy and about 600 MWh/year of thermal energy, with a reduction in CO₂ emission of around 174 tons per year and also the energy saving, in terms of “Tons of Oil Equivalent”, has been calculated around a mean value of 24 tons/year.

1. Introduction

In the industrial and civil environment, a significant opportunity to save energy comes from waste heat recovery (WHR).

It often happens that this possibility is not utilized, in particular in the cases of thermal and electric energy transformations or in industrial production processes.

Potentially suitable sectors for WHR are the production of glass, paper, cement or petrochemical, iron and steel, food and power generation, where the waste heat is available as gas flow at high temperature. Sometime the practice of WHR can be eligible for economic incentives, reducing in such way the powerplant costs, the payback time and increasing the net income. The simpler, cheaper and more profitable WHR plant consists of a use for heating of rooms in civil homes or factories.

However, this solution cannot sometimes be followed, due to the absence of thermal utilities: therefore the use of plants for the production of electricity through the WHR represents in this case a



possible alternative. The main aspects that make it possible the introduction of these power plants in the industrial area are:

- easy installation of the systems
- the proximity of the heat generator system with the plant that exploits it
- high number of operating hours
- adequate temperature level of the heated fluid

One of the solutions adopted for this purpose is the installation of Organic Rankine Cycle (ORC). Thanks to ORC technology, many technological barriers, as changes to the original plants, have been overcome and the WHR at medium-low temperatures, also in the case of non constant thermal sources and of reduced amount, can be today a possible objective both for technical and economic aspects [1,2,3]. As final consideration, the ever increasing attention to the reduction of primary energy consumption (sometimes a necessary restriction for highly energy-intensive industrial activities), can improve the efficiency of industrial processes with a not negligible contribution towards the goal of “2020 climate & energy package”, that is 20% cut in greenhouse gas emissions (from 1990 levels), 20% of EU energy from renewable, 20% improvement in energy efficiency.

2. The steel hot-forging industry description

The considered manufacturing plant, which is located in Nord-West Italy, operates in the steel processing field, in particular in the hot-forging of steel for the production of mechanical components for industrial and agricultural machinery, such as gears for gearboxes, flanges, rings, etc., mainly for application on agricultural vehicles. The main production line consists of a pneumatic system, used to move the steel bars, which, after being loaded onto a special track system, are pushed towards the entrance door of the natural gas oven (see Figure 1). The oven heats the metal bars and brings them up to a temperature of around 1000 [°C].

After reaching the set temperature, the bars are pushed through the exit door of the oven where they are cut by means of a system of shears (see Figure 2). Thanks to a conveyor belt, the hot pieces are transported to a pneumatically driven press and a mallet, where the final hot processing takes place.



Figure 1. Special pneumatic track system used to move the steel bars.

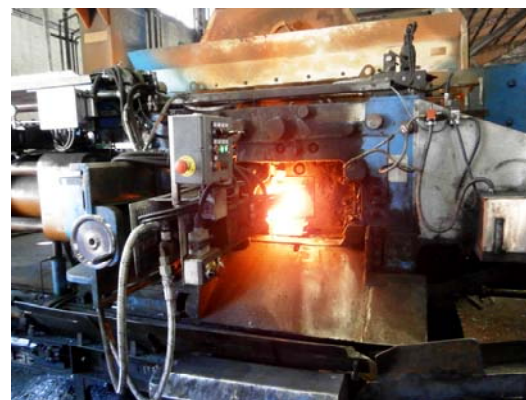

Figure 2. The exit door of the oven where the steel bars are cut by means of shears system.

The methane oven with an extractor hood used to heat the steel bars is instead shown in Figure 3: the exhaust gases coming from the oven and sucked out by this hood are then used for the WHR.



Figure 3. Methane oven in the factory for the heating of steel bars with extractor hood

In addition to the natural gas, the manufacturing plant uses a considerable amount of compressed air, which is necessary for the mallet. The compressed air is produced by a group of five screw compressors which, together with the pneumatically driven press, the oven fans, the special track system and the auxiliary systems, consume an intensive amount of electric energy. An in-depth analysis in this technological activity inside the factory, concerning the consumption of natural gas and electricity, was therefore necessary.

Five months of plant activity, from February to June, were taken into consideration to examine the average gas and electricity consumption of the plant (see Figures 4 and 5).

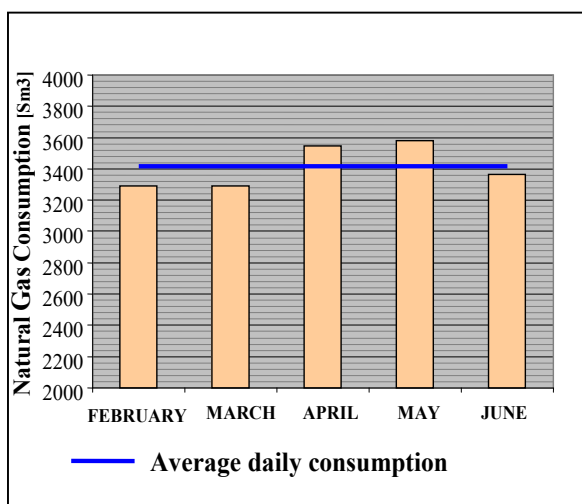

Figure 4. Natural Gas consumption over the five considered months

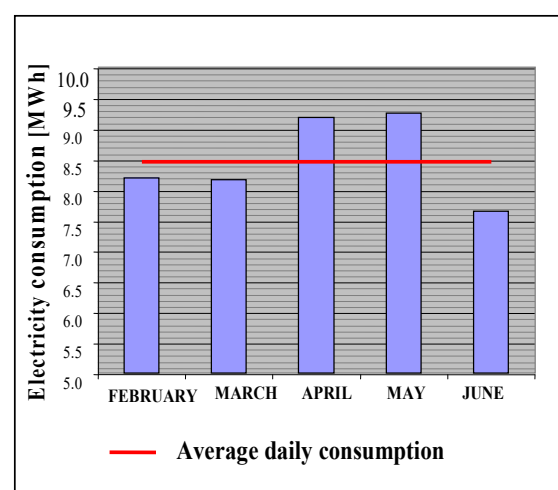

Figure 5. Electricity consumption over the five considered months

3. Determination of the available thermal power

In order to determine the electrical energy that can be produced with WHR, only the operating mode will be considered hereafter. The daily hours of activity of the furnace were assumed equal to 14, with respect the 14 total working hours, that is, only the full-load operating condition was assumed for 220 days a year, when the production line was active.

The exhaust gas volumetric flow rate to the chimney during oven operation was obtained starting from the flow rate produced by the burner and deducing the flow rate of the fumes exiting from the loading and unloading doors of the over, which was estimated to be about 20% of the total. The gas flow rate for temperature and pressure conditions of 20 [°C] and 101325 [Pa] resulted to be: $Q_{eg} = 3800 [m^3/kg]$.

It was taken into account that the burned gas, produced by the combustion of natural gas, before reaching the expulsion duct, by means of natural convection (therefore without suction fans), crossed one and a half meters of air, where it was mixed and then cooled down (see Figure 3). The maximum available temperature of the fumes entering the extraction hood connected to the chimney was about 700 [°C], with a density of 1.205 [kg/m³] and, consequently, the mass flow rate \dot{m}_{eg} of the exhausted gas that could be used for WHR was 1.272 [kg/s]. Furthermore, it was assumed that the fumes would be intercepted in the exhaust pipe, when these had a temperature of about 650 [°C] and, to avoid the formation of condensation in the chimney, it was hypothesised utilizing the fumes until they reached a temperature of about 130 [°C]. Under these hypotheses, it was possible to calculate the maximum thermal power, Φ_{eg} , theoretically recoverable from the exhausted gases, i.e.:

$$\Phi_{eg} = \dot{m}_{eg} \cdot C_{peg} \cdot \Delta T_{eg} = 727.6 [kW] \quad (1)$$

where: $\Delta T_{eg} = (650 - 130) [°C]$, and the average value of the specific heat at a constant pressure of the exhaust gases $C_{peg} = 1100 [J/(kg \text{ } °C)]$.

From this thermal power, it was possible to find the most suitable system solution to maximize the producible electric energy. Subsequently, it was also considered very important to evaluate the economic feasibility of the powerplant, as well as the technical feasibility.

4. Adopted power plant solution

A fundamental problem immediately emerged in the case study: although the burned gases are available at a high temperature, the thermal power associated with them is somewhat limited. Moreover, considering the necessity of avoiding high pressure systems in the manufacturing plant, resorting to the use of a recovery system that exploits water steam in a Rankine-Hirn cycle was not considered convenient. Therefore, the choice fell upon the ORC technology, which is a reliable solution and it allows waste energy to be recovered and exploited, even when the source is variable over time, as in the case of thermal waste from a production process in a steel hot-forging industry. ORC modules, which are available with different electric-generator sizes, constitute a very compact technology that is suitable for installation in limited spaces: the entire system is often mounted onto a frame that only needs a few square meters. The problem of the application of this solution, with the thermal recovery of fumes at high temperatures, concerns the deterioration of the organic fluid above a certain temperature, which is usually much lower than the 650 [°C] available in this case.

Therefore, the problem of maximizing the available thermal power, while avoiding reducing the temperature at which the flue gases are intercepted in the chimney for the recovery system too much, basically consists in choosing an appropriate fume-water (or diathermic oil) heat exchanger that is able to withstand high thermal stress. If an available thermal power of 727.6 [kW_{th}] is considered, the most suitable ORC system was chosen with a thermal input of 550 [kW_{th}], as shown in Table 1, but with also some other characteristics. This was the closest size to the recovered thermal power. The plant is shown in Figure 6; the dimensions of the plant are: length 3950, height 2038 and width 1200 [mm].

Table 1. Main characteristics of the ORC module

Thermal input power [kW_{th}]	Electric output power [kW_{el}]	Electric efficiency [%]	Working fluid (eco-friendly)	Carrier fluid	Carrier fluid inlet temp. [$^{\circ}C$]	Carrier fluid outlet temp. [$^{\circ}C$]	Carrier fluid mass flow rate [kg/s]
550	50	9.6	HFC blend	Hot water	≥ 94	86	14.93

The Pre-Heater performs a preheating of the working fluid using the hot water from the thermal circuit fed to the ORC system. The evaporator, which is connected in series with the pre-heater, uses the heat from the same hot water to vaporize the organic fluid. The turbine, which is of a radial type, is coupled directly to the generator shaft, and the rotational speed is set between 12000 and 18000 [rpm]. The thermodynamic characteristics of the working fluid are: inlet temperature of the organic fluid $85^{\circ}C$; outlet temperature of the organic fluid $\sim 60^{\circ}C$; stage pressure 4.42 bar.

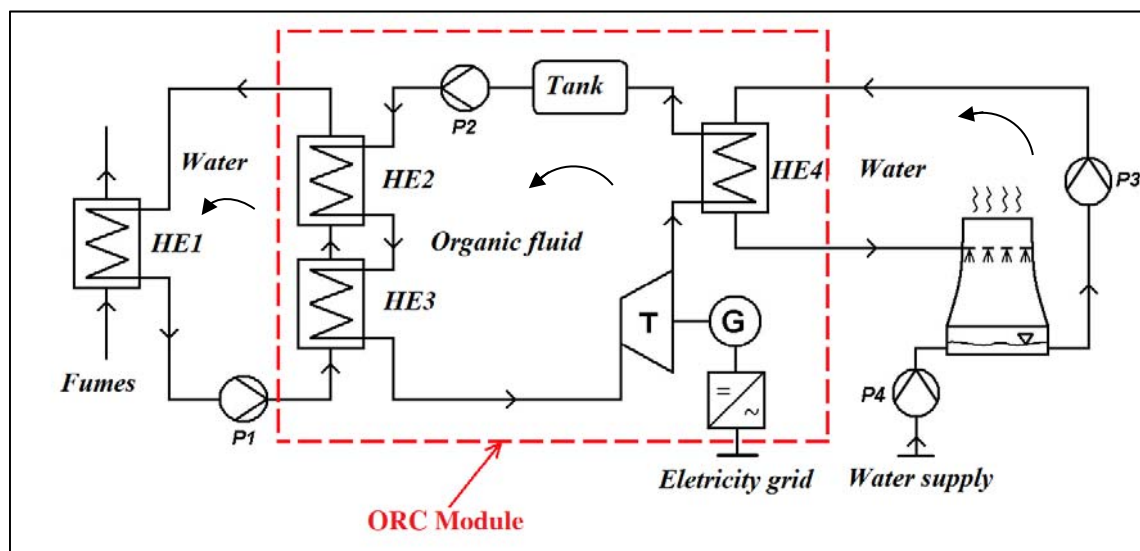

Figure 6 - Scheme of the ORC module and of the relative plant components. Legend of symbols: HE1 Fume-water heat exchanger; HE2 Pre-Heater; HE3 Evaporator; HE4 Condenser; P1÷P4 Fluid circulation pumps; T Turbine; G Electric generator

A permanent 50 [kW_{el}] magnet synchronous electric generator is installed on the ORC module, with a nominal rotation speed of 15000 [rpm]. Other characteristics of the electric generator are: cooling system with water/glycol refrigerant fluid; thermal power to be removed 5 [kW_{th}]; fluid inlet temperature $< 40^{\circ}C$; flow rate of the fluid 10 [l/min]. The inverter is placed downstream of the generator and it adjusts the phase, frequency and voltage of the electric current produced by the generator to allow the alternator to be interfaced with the national electricity grid. The inverter characteristics are: power 50 [kW_{el}]; voltage 400 [V]; frequency 50 [Hz]; air cooling system. Condenser: in this heat exchanger, the organic working fluid in the gaseous phase at the outlet of the turbine returns to the original liquid phase. The tank, with a capacity of 90 litres, has the function of collecting the organic working fluid, in liquid form, as it leaves the condenser. The three heat exchangers used in the ORC module (pre-heater, evaporator, condenser) are of the brazed plate type.

The construction technology is based on the coupling of several steel plates, without gaskets, which are welded together by means of copper brazing in vacuum furnaces: this makes this type of exchanger suitable for working with fluids at high pressures and temperatures.

The passage sections of the fluids are very limited, and the overall dimensions of these exchangers are minimal in relation to their heat exchange capacity. The pumps have the function of circulating the fluid in the various circuits and, in particular, for the organic fluid, of raising the pressure to the necessary level for its evaporation.

Finally, if the residual heat that has to be disposed off for the condensation of the working fluid is not used, it is possible to introduce, as an alternative solution, a system composed of two evaporative towers with axial fans which have the following technical characteristics: dissipative yield 500 [kW_{th}]; electric power absorbed from fan 4 [kW_{el}]; air flow 16.8 [m³/s]; reintegration water flow rate 13.2 [l/min]; dimensions 3653 x 3213 x 1146 [mm].

5. Analysis of different operating conditions of the ORC module

The electric power generated by the ORC module vs water mass flow rate necessary to remove heat from the fumes, for an inlet hot water at the pre-heater of 96 [°C] and for an inlet cold water at the condenser of between 24 °C and 30 [°C], is shown in Figure 7; the experimental points are also interpolated through a second-order polynomial regression

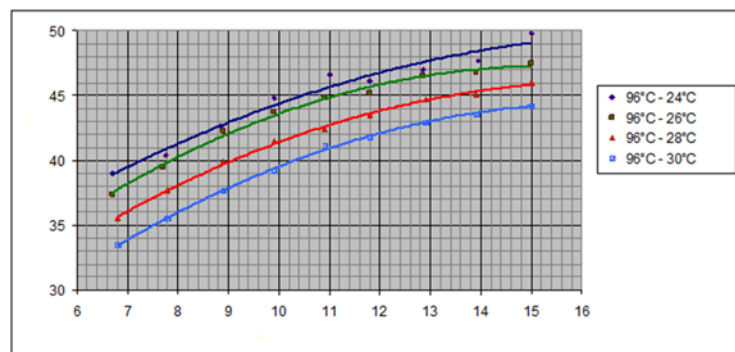

Figure 7. Electric power generated by the ORC module vs water mass flow rate for an inlet hot water at pre-heater of 96 °C and for an inlet cold water at condenser between 24 and 30 °C

As can be seen, the electric power produced by the ORC generator module increases as the flow of hot water entering the pre-heater increases as a result of the heat transfer to the working fluid and its subsequent evaporation in the evaporator. Moreover, the generated electric power increases as the temperature of the cold water entering the condenser decreases to remove heat from the organic fluid and bring it back to its liquid state. An electric power of 50 [kW_{el}] can therefore be reached with a thermal input power Φ_{H2O} to the ORC module with a water mass flow rate of 15 [kg/s], an inlet hot water at pre-heater of 96 [°C], an outlet temperature of 86 [°C] and for an inlet cold water at the condenser of 24 [°C]:

$$\Phi_{H2O} = \dot{m}_{H2O} \cdot C_{H2O} \cdot \Delta T_{H2O} \approx 628 [kW_{th}] \quad (2)$$

which is the input thermal power, and it is just above the nominal value of 550 [kW_{th}], but below the maximum thermal power theoretically recoverable from the exhausted gases, calculated from equation (1).

6. Results and discussions

The cumulative cash flows and payback period was first evaluated in a scenario in which the economic incentive was not considered and then considering the benefits, in the 5 years of useful life, linked to energy efficiency certificates (whose total value is € 50160 for 5 years). In the first case the payback

period the investment between the 19th and the 20th year, while in the second case (with economic incentives) between the 17th and the 18th year, as shown in Figure 8.

Unfortunately, as can be seen more easily from the graphs, we are still far from the condition usually expected by private investors of having a maximum period of 5 years to decide whether to make the investment. Despite the possibility of accessing the incentive mechanism for white certificates, which in the case in question determines a reduction of 2 years in the time of recovery of the initial outflow, this is not decisive in ensuring the feasibility of the investment. The reasons for such a long payback period are to be found in the hourly operating profile of the production line adopted by the company where it was planned to install the ORC power plant. The 14 hours/day of full operation of the gas oven, from which it was intended to recover the thermal energy associated with the exhaust fumes, are not sufficient to determine a re-entry time of less than 5 years.

In the examined situation, it was expected that the electricity generating plant would work for about 3080 hours/year (14 hours/day and 220 days/year). As this type of ORC systems can operate for more than 7500 hours per year for 15 years, it is clear that the module would be widely underutilizing. However, due to its low level of daily use and thanks to the annual maintenance planned for the plant, it is foreseeable that this could generate energy without any problems connected to failures or malfunctions for the entire duration of its technical life, that is, for 20 years.

If the return on investment time is not considered, it can be seen that in the incentivized case, at the end of the technical life, a very low cumulative cash flow (about 63000 Euros) would be obtained, compared to the initial investment of 480000 Euros.

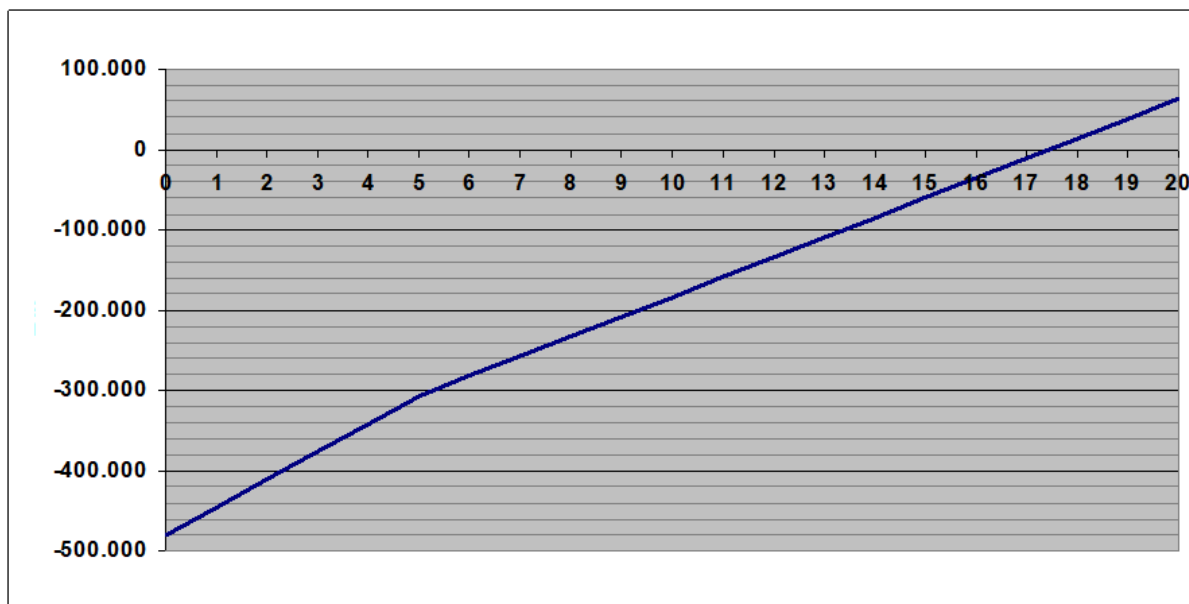

Figure 8. Cumulative cash flow and payback period of the ORC power plant for twenty years with only the production of electricity in presence of benefits in the first 5 years.

Owing to the unsatisfactory economic return of the plant when only used for with only the production of electricity, it has been necessary to introduce the valorisation of the heat output from the ORC module, as shown in Figure 9. Therefore, the hypothesis of a district heating network taking advantage of the heat from the condenser of the ORC module, in order to heat the rooms of some public and utility buildings near the steel hot-forging industry, was taken into consideration.

The heating season has been estimated to last 7 months, with a profile for public utilities of 20 days a month and 12 hours a day (from 6 am to 6 pm). An additional heating system would be necessary for private users in order to cover each day of the week and to extend the heating after 6 pm. The thermal power that must be removed from the organic fluid in the condenser of the ORC module for the district heating networks is 470 kW_{th}, but, in the absence of a thermal utility capable of continuously absorbing the heat exiting from the condenser of the ORC module throughout the entire

year, it was necessary to preserve maintain the water-cooling circuit with an evaporative tower, as shown in Figure 9. It was is therefore necessary (with reference to Figure 9) to install a second condenser (HE5), two three-way valves (V1 and V2), a circulation pump (P5), two energy meters, C1 and C2, and two control valves, R1 and R2. The characteristics of the module are shown in Table 2 with the additional thermal recovery that could be achieved for district heating networks. The net thermal power, Φ_{DHN} , for the district heating networks is 359.6 [kW_{th}], compared to the 470 [kW_{th}] available at condenser HE5 and to 323.6 [kW_{th}] provided to the utilities. This is due to the heat exchange efficiencies of HE5, HE6 and HE7 and to the presence of heat exchanger utility connections in the substations. Finally, the low temperatures, T_c, T_c' and T_f, T_f' , are due to the choice of using radiant panel floors for the final utilities.

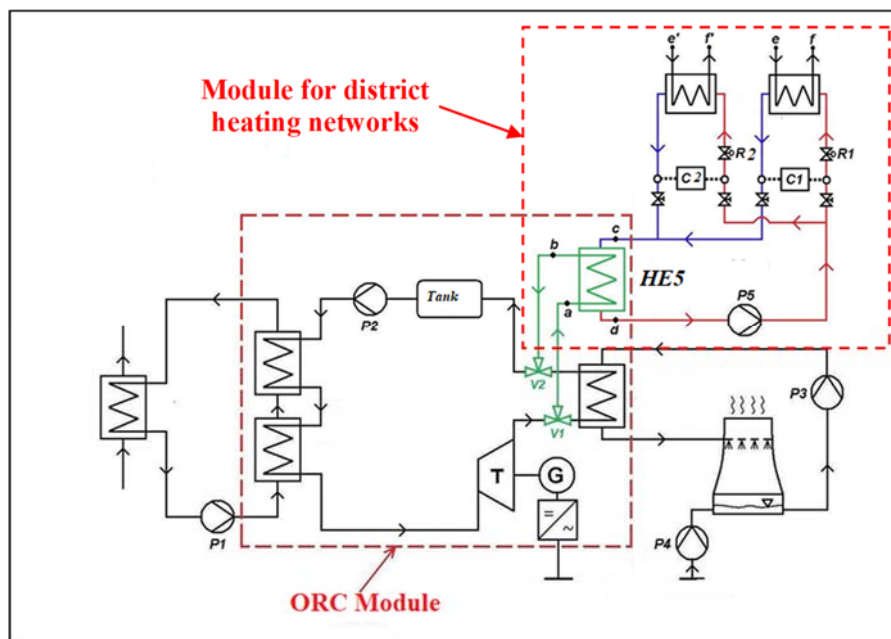

Figure 9. Scheme of the ORC module with additional thermal recovery for district heating networks. Legend of symbols: HE5 organic fluid-water heat exchanger; HE6, HE7 heat exchanger for district heating networks; P5 water circulation pump; V1, V2 three-way valves; C1, C2 energy meters; R1, R2 control valves.

The thermal power of 359.6 [kW_{th}] provided to the utilities, with a total thermal energy of 604 MWh/year and a selling price of 84.7 €/MWh (for 7 months/year, as previously mentioned), makes an economic growth of 51159 €/year possible. An additional cost of 20,000 Euros, linked to the installation of the second condenser to supply heat to the district heating network was taken into consideration to calculate the new payback period. The costs of installing a district heating network, with reference to a linear metre of pipes, range from about € 200/m for smaller networks, to over € 500/m for larger networks, where the main network has a greater extension. In this case, assuming a reference cost of € 200/m, and a pipe length of 500 [m] for the heat distribution line, an extra cost of approximately € 100,000 can be expected. Moreover, if the additional expenses necessary to set up a district heating network are considered, the total cost of the investment should amount to 600000 Euros.

Table 2. Main characteristics of the thermal recovery module for district heating networks

Φ_{DHN}	T_a	T_b	T_c	T_d	$T_e, T_{e'}$	T_f, T_f'	HE5
Net power for heating netw. [kW_{th}]	Inlet HE5 ORC fluid [$^{\circ}C$]	Outlet HE5 ORC fluid [$^{\circ}C$]	Inlet HE5 Water [$^{\circ}C$]	Outlet HE5 Water [$^{\circ}C$]	Inlet HE6-7 Water [$^{\circ}C$]	Outlet HE6-7 Water [$^{\circ}C$]	Water mass flow rate [kg/s]
359.6	55	30	24	50	30	38	3.89

The return time of the investment was again calculated and the payback period, in the hypothesis of selling the condensation heat of the organic fluid of the ORC module, is substantially reduced to just over 7 years.

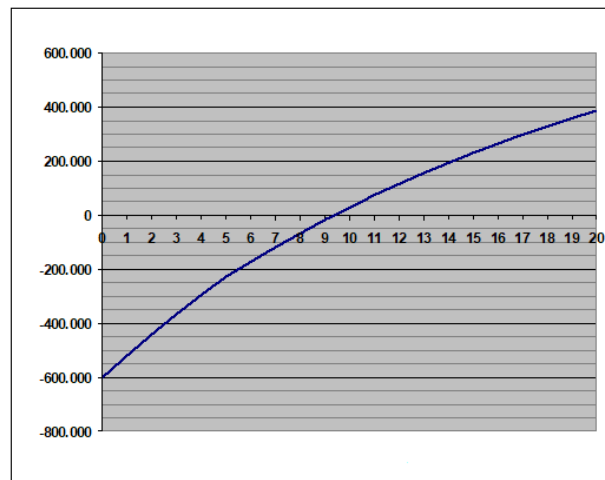

Figure 10. Cumulative discounted cash flow and Net Present Value index with additional thermal recovery for district heating networks

In this latter scenario, when the net present value index (NPV) is calculated with a discount rate of 5%, a noticeable improvement can be noted: when the economy income from the district heating service is included, a positive NPV of 388000 Euros, as shown in Fig.10, can be observed at the end of the technical life of the module. This positive NPV indicates that the investment of the ORC module should be considered economically sustainable.

7. Conclusions

An Organic Rankine Cycle (electric power of 50 [kW_{el}]) was first analysed with the aim of recovering thermal energy in a steel hot-forging industry, for the case of electricity production alone: about 8.2% of the total electricity consumption, that is, 154 MWh/year was calculated. The low profitability of the investment, that is, 480000 Euros, even when economic incentives were considered, resulted from the limited number of operating hours of the recovery system. In fact, by analyzing the economic feasibility of the ORC power plant, the simple calculation of the payback period led to 17÷18 years. Moreover, the calculation of the Net Present Value with the cumulative discounted cash flow also indicated that the investment was not profitable. In a second case study, in which additional thermal recovery for district heating networks was considered, both the simple calculation of the payback period and the Net Present Value with the cumulative discounted cash flow, indicated a real economic possibility of the investment, which resulted to be of 600000 Euros. The simple calculation of the payback period in fact led to 7÷8 years and a positive NPV of 388000 Euros at the end of the technical life of the power plant.

As far as the environmental aspects are concerned, thanks to the self-consumption of electricity produced through the ORC module, as an alternative to the purchase of the same amount of electricity from the national distribution network, the amount of carbon dioxide that can be avoided in the

atmosphere resulted to be 50.32 tons/year. Assuming that 604 MWh/year of thermal energy were produced, which could be supplied, via district heating, to the users, it would be necessary to employ a gas boiler, and the emissions into the atmosphere would result to be 123.92 tons of CO₂/year. Therefore, this value represents the carbon dioxide emissions that would be avoided, thanks to the recovery heat for the district heating network. Overall, the installation of the ORC module would reduce the CO₂ emissions by an amount of 174.24 tons CO₂/year [7]. The energy savings, in terms of “Tons of Oil Equivalent” (TOE), has also been calculated [6]. In the first five years, the achieved savings were found to be constant and equal to 28.8 TOE/year. However, the performance decay should be taken into account, from the sixth year onwards, and this would gradually reduce the savings over the years to 19.62 TOE/year at the end of the technical life of the power plant with an average value of about 24 tons/year. Definitely, although the proposed plant solution was found to be rather costly, the ORC technology is substantially promising, especially if the energy field needs additional input from renewable energies, for efficiency improvement of civil or industrial activities, or to pursue pollutant emission reduction policies.

Acknowledgment

The authors would like to express their gratitude to Dr. Eng. Tarcisio Fassero of Cisar S.r.l and to Zuccato Energia S.r.l for the support in the preparation of this work

References

- [1] Z. Fergani, D. Touil and T. Morosuk, “ Multi-criteria exergy based optimization of an Organic Rankine Cycle for waste heat recovery in the cement industry,” *Energy Conversion and Management*, 112, pp. 81–90, 2016.
- [2] Y. Feng, T.C. Hung, K. Greg, Y. Zhang, B. Li and J. Jang, “Thermodynamic comparison between pure and mixture working fluids of Organic Rankine Cycles (ORCs) for low temperature waste heat recovery,” *Energy Conversion and Management*, 106 pp. 859–872, 2015.
- [3] Ö. Kaska, “ Energy analysis of an organic Rankie for power genwration from waste heat recovery in steel industry,” *Energy Conversion and Management*, 77 pp. 108–117, 2014.
- [4] F. Bertrand Tchanche, Gr. Lambrinos, A. Frangoudakis, G. Papadakis, “Low-grade heat conversion into power using organic Rankine cycles – A review of various applications”, *Renewable and Sustainable Energy Reviews* 2011,
- [5] G. De Simon, D. Micheli, R. Taccani, “Analisi delle prestazioni di un gruppo ORC operante con alcune miscele di polisilossani”. *Congresso ATI, Roma 2005*.
- [6] “Guida operativa/3.1 per ottenere i titoli di efficienza energetica velocemente, sicuramente alla luce del Decreto 28 Dicembre 2012”. *ENEA, 2014*.
- [7] ISPRA, “Fattori di emissione atmosferica di CO₂ e sviluppo delle fonti rinnovabili nel settore elettrico”, *Rapporto 212/2015*,