

Variability analysis of a boost converter based on an iterative and decoupled circuit implementation of the stochastic Galerkin method

Original

Variability analysis of a boost converter based on an iterative and decoupled circuit implementation of the stochastic Galerkin method / Manfredi, Paolo; Trincherò, Riccardo; Vande Ginste, Dries. - ELETTRONICO. - (2018), pp. 996-1000. (Intervento presentato al convegno 60th IEEE International Symposium on Electromagnetic Compatibility and 9th IEEE Asia-Pacific Symposium on Electromagnetic Compatibility (EMC&APEMC 2018) tenutosi a Singapore nel 14-18 May 2018) [10.1109/ISEMC.2018.8393935].

Availability:

This version is available at: 11583/2715451 since: 2018-10-19T18:38:53Z

Publisher:

Institute of Electrical and Electronics Engineers Inc.

Published

DOI:10.1109/ISEMC.2018.8393935

Terms of use:

This article is made available under terms and conditions as specified in the corresponding bibliographic description in the repository

Publisher copyright

IEEE postprint/Author's Accepted Manuscript

©2018 IEEE. Personal use of this material is permitted. Permission from IEEE must be obtained for all other uses, in any current or future media, including reprinting/republishing this material for advertising or promotional purposes, creating new collecting works, for resale or lists, or reuse of any copyrighted component of this work in other works.

(Article begins on next page)

Variability Analysis of a Boost Converter Based on an Iterative and Decoupled Circuit Implementation of the Stochastic Galerkin Method

Paolo Manfredi and Riccardo Trinchero
Department of Electronics and Telecommunications
Politecnico di Torino
Turin, Italy 10129
Email: paolo.manfredi@polito.it

Dries Vande Ginste
Department of Information Technology, IDLab
Ghent University – imec
Ghent, Belgium 9052

Abstract—This paper proposes a decoupled and iterative circuit implementation of the stochastic Galerkin method (SGM) for the variability analysis of electrical circuits via polynomial chaos (PC). The method is based on a perturbative reformulation of the SGM, resulting in a decoupled system with equivalent sources that is solved iteratively by suitably updating the sources at each step. This alternative approach is easier to implement and its computational cost scales linearly with the number of unknown PC coefficients. This contribution addresses the case of stochastic resistors. As a validation, the technique is applied to the variability analysis of a boost converter.

Index Terms—Circuit simulation, perturbation methods, polynomial chaos, statistical analysis, stochastic Galerkin method, switching converters.

I. INTRODUCTION

Polynomial chaos (PC) techniques have recently become widely popular in the variability analysis of electrical circuits [1]–[7]. They are based on expanding circuit voltages and currents into a series of orthogonal polynomials, whose coefficients directly provide relevant statistical information. Most of the strategies to solve for these unknown expansion coefficients rely on either the intrusive so-called stochastic Galerkin method (SGM) [1]–[3] or on non-intrusive (typically, sampling/collocation based) approaches [5]–[7].

The choice between intrusive and non-intrusive methods mainly depends on whether the goal is to achieve a higher accuracy or a higher computational efficiency and ease of implementation. Indeed, the SGM is considered to be the most rigorous and accurate technique, but it suffers from a few important limitations. The SGM recasts the original stochastic equations into a deterministic augmented problem coupling all the PC expansion coefficients. Because of this, it scales unfavorably with the number of unknowns (which is in turn related to the number of random parameters) and possibly requires to develop an ad-hoc solver to handle the new problem.

The latter issue was partially mitigated by the approach proposed in [3], in which an equivalent circuit interpretation was given to the SGM problem. This allowed generating a companion deterministic circuit starting from the original

stochastic circuit, which could be simulated by many available circuit simulators without modifications of the underlying solver. Nevertheless, besides not solving the first issue, the models require the extensive use of controlled sources, which limits the applicability to advanced circuit simulators only, and still requires to develop ad-hoc circuit models depending on the specific library components that are available.

This paper proposes a novel solution that alleviates both aforementioned limitations. By leveraging a perturbative approach, an iterative and decoupled reformulation of the SGM is introduced, with several important benefits. First of all, the solution involves the iterative solution of multiple problems that have the same size as the original one, thus scaling linearly with the number of unknown PC coefficients. Second, these problems have a much simpler circuit interpretation, which is very similar to the original circuit, but where each stochastic element is treated as being deterministic and is equipped with a suitable equivalent independent source.

This contribution addresses the case of stochastic resistors and shows the feasibility of the proposed approach. To illustrate the method, the analysis of a DC-DC boost converter is considered, in which components uncertainties affect conducted emissions [8]. The simulations are carried out in Simulink, which is a powerful environment for the simulation of time-varying systems, but for which the implementation of the circuit models in [3] would become rather cumbersome.

II. CIRCUIT ANALYSIS VIA PC AND SGM

Consider the case of a stochastic resistor, whose resistance R exhibits a Gaussian distribution with mean value R_0 and standard deviation R_1 , i.e., $R \sim \mathcal{N}(R_0, R_1^2)$. The stochastic value of the resistance can be expressed as $R(\xi) = R_0 + R_1 \cdot \xi$, where $\xi \sim \mathcal{N}(0, 1)$ is a *standard* Gaussian random variable with zero mean and unitary variance.

The Ohm's law relating the current and voltage across the resistor at each time t reads

$$v(t, \xi) = R(\xi) \cdot i(t, \xi) = (R_0 + R_1 \xi) \cdot i(t, \xi), \quad (1)$$

where the voltage v and the current i become also function of ξ , and hence stochastic.

The PC approach to circuit analysis represents stochastic voltages and currents as expansions

$$v(t, \xi) \approx \sum_{k=0}^K v_k(t) \varphi_k(\xi), \quad i(t, \xi) \approx \sum_{k=0}^K i_k(t) \varphi_k(\xi), \quad (2)$$

where the φ_k are polynomials of degree k in the random variable ξ , which are orthonormal based on the inner product

$$\langle f, g \rangle = \int_{-\infty}^{+\infty} f(\xi)g(\xi) \frac{e^{-\xi^2/2}}{\sqrt{2\pi}} d\xi. \quad (3)$$

The polynomials satisfying the above orthogonality condition are the Hermite polynomials [9]. Typically, a second-order expansion ($K = 2$ in (2)) suffices and is therefore considered in the remainder of the paper. The first three orthonormal Hermite polynomials are $\varphi_0 = 1$, $\varphi_1 = \xi$, $\varphi_2 = (\xi^2 - 1)/\sqrt{2}$.

The sought-for coefficients v_k and i_k define a compact stochastic model for the voltages and currents in the form of (2), from which statistical information is readily extracted using analytical or numerical (e.g., sampling based) methods. Moreover, following the properties of PC expansions, the average and standard deviation are readily given, e.g. for the voltage, by v_0 and $\sqrt{\sum_{k=1}^K v_k^2}$, respectively, and similarly for the current.

Noticing that $R(\xi) = R_0\varphi_0(\xi) + R_1\varphi_1(\xi)$, substituting the PC expansions (2) into (1), and performing a Galerkin projection [10], yields the following augmented deterministic equation relating the voltage and current PC coefficients:

$$\begin{bmatrix} v_0(t) \\ v_1(t) \\ v_2(t) \end{bmatrix} = \begin{bmatrix} R_0 & R_1 & 0 \\ R_1 & R_0 & \sqrt{2}R_1 \\ 0 & \sqrt{2}R_1 & R_0 \end{bmatrix} \begin{bmatrix} i_0(t) \\ i_1(t) \\ i_2(t) \end{bmatrix} \quad (4)$$

It is important to remark that, in the system (4), the voltage and current coefficients are coupled. Fig. 1(a) shows the corresponding circuit interpretation, where series current-controlled voltage sources provide the necessary coupling between the PC expansion coefficients.

Alternatively, the system (4) can be inverted in order to express the current coefficients in terms of the voltage ones. In this dual circuit, parallel voltage-controlled current sources provide the necessary coupling, as shown in Fig. 1(b), where the elements G_{ij} denote the entries of the inverse of the resistance matrix in (4). This voltage-driven model is more suitable for circuit solvers that are based on the modified nodal analysis (MNA) formalism [11], since the former would introduce two additional unknowns (i.e., the voltage of the node between the resistor and the voltage source, and the current flowing through the voltage source itself).

Once the model of the stochastic resistor is obtained, it is connected to analogous models for the other stochastic and non-stochastic components in the network, in accordance with the original topology. This results in an augmented and coupled deterministic network that is simulated once to

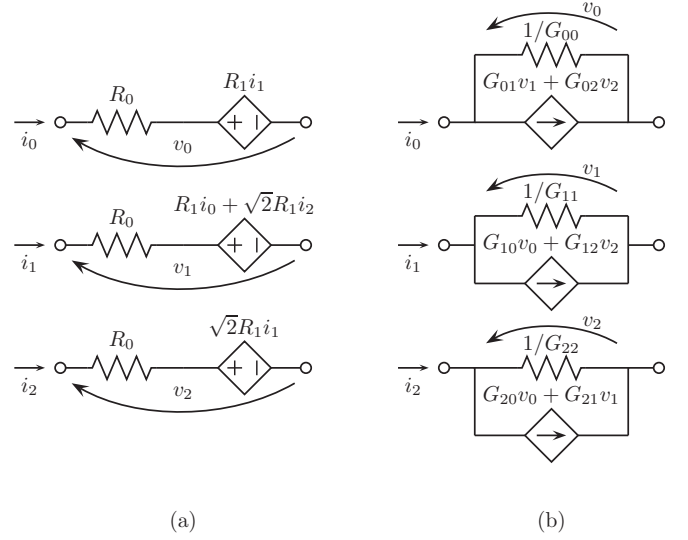

Fig. 1. Equivalent circuit interpretation of the SGM problem for a stochastic resistor: current-driven model (a) and voltage-driven model (b).

obtain the PC expansion coefficients of all circuit voltages and currents [3].

The generalization to multiple random parameters is straightforward. The multivariate basis functions include all the combinations of the univariate polynomials up to a total degree p . The resulting number of terms in the PC expansion is given by [9]

$$K + 1 = \frac{(p + d)!}{p!d!}, \quad (5)$$

where d is the number of random parameters.

The system of equations (4) has the same size as the number of coefficients (5). In the general case, the system (4) and the corresponding circuit are fully coupled, making the complexity to grow faster than linearly. Furthermore, the implementation of the couplings could be cumbersome, for example in simulators that do not allow a straightforward definition of controlled sources with multiple controlling variables. While keeping this in mind, the discussion in the following section considers again the case of a single random parameter ($d = 1$) for the sake of simplicity.

III. PERTURBATIVE MODEL

The novel approach starts by interpreting the resistance variation as a random perturbation of its nominal (mean) value, i.e.,

$$R(\xi) = R_0 + \Delta R(\xi) \quad (6)$$

with $\Delta R(\xi) = R_1 \cdot \xi$. The substitution into (1) leads to

$$v(t, \xi) = R_0 i(t, \xi) + \Delta R(\xi) i(t, \xi). \quad (7)$$

In the above equation, the second term in the r.h.s. can be thought of as a first order perturbation of the resistor voltage. As such, (7) can be solved iteratively, with the voltage and

current at the m th iteration step, denoted with $v^{(m)}$ and $i^{(m)}$, respectively, being related by

$$v^{(m)}(t, \xi) = R_0 i^{(m)}(t, \xi) + \Delta R(\xi) i^{(m-1)}(t, \xi), \quad (8)$$

with $m \geq 0$ and $i^{(-1)}(t) = 0$. Provided that the perturbation in (6) is ‘‘small enough’’, the quantities $v^{(m)}$ and $i^{(m)}$ (quickly) converge to the actual values of the voltage and the current. A rigorous convergence analysis is out of the scope of this paper.

Nonetheless, for the sake of illustration, consider the iterative solution for the case of a resistor with a nominal value $R_0 = 5 \Omega$ that is perturbed by $\Delta R = 2 \Omega$ and is paralleled by an independent DC voltage source $E = 10 \text{ V}$. In this trivial case, the current at step m is $i^{(m)} = (E - \Delta R i^{(m-1)})/R_0$, whereas the correct asymptotic value is $i = E/(R_0 + \Delta R) = 1.429 \text{ A}$. As can be seen from Table I, the convergence of the iterations is relatively fast despite a 40% perturbation of the resistance value.

TABLE I
ITERATIVE CALCULATION OF THE CURRENT THROUGH A PERTURBED RESISTANCE SUBJECT TO A CONSTANT VOLTAGE.

step m	$\Delta R i^{(m-1)}$	$i^{(m)}$	relative error
0	0	2 A	40%
1	4 V	1.2 A	16%
2	2.4 V	1.52 A	6.4%
3	3.04 V	1.392 A	2.6%
4	2.784 V	1.443 A	1.0%
5	2.886 V	1.423 A	0.4%
6	2.845 V	1.431 A	0.1%
7	2.862 V	1.428 A	<0.1%
\vdots	\vdots	\vdots	
exact value		1.429 A	

It should be noted that $\Delta R(\xi) = R_1 \cdot \varphi_1(\xi)$ and it has zero mean. Expanding the voltage and the current at each perturbation step in terms of (2), the Galerkin projection of (8) yields

$$\begin{bmatrix} v_0^{(m)}(t) \\ v_1^{(m)}(t) \\ v_2^{(m)}(t) \end{bmatrix} = \begin{bmatrix} R_0 & 0 & 0 \\ 0 & R_0 & 0 \\ 0 & 0 & R_0 \end{bmatrix} \begin{bmatrix} i_0^{(m)}(t) \\ i_1^{(m)}(t) \\ i_2^{(m)}(t) \end{bmatrix} + \begin{bmatrix} 0 & R_1 & 0 \\ R_1 & 0 & \sqrt{2}R_1 \\ 0 & \sqrt{2}R_1 & 0 \end{bmatrix} \begin{bmatrix} i_0^{(m-1)}(t) \\ i_1^{(m-1)}(t) \\ i_2^{(m-1)}(t) \end{bmatrix}, \quad (9)$$

which describes the relation between the perturbations of the voltage and current PC coefficients. Equation (9) is similar to (4), but with two notable differences:

- the PC coefficients at a given iteration step are decoupled (cfr. the first term in the r.h.s. of (9));
- the coupling terms are explicitly known in terms of the solution of the previous iteration step (second term in the r.h.s. of (9)).

Therefore, the coupling between the PC coefficients is no longer simultaneous and, at each step, the PC coefficients can be computed separately by considering the equation

$$v_k^{(m)}(t) = R_0 i_k^{(m)}(t) + v_{eq,k}^{(m)}(t), \quad (10)$$

with $k = 0, 1, 2$, where the second term in the r.h.s. plays the role of a known equivalent voltage source with value

$$\begin{cases} v_{eq,0}^{(m)}(t) = R_1 i_1^{(m-1)}(t) \\ v_{eq,1}^{(m)}(t) = R_1 i_0^{(m-1)}(t) + \sqrt{2}R_1 i_2^{(m-1)}(t) \\ v_{eq,2}^{(m)}(t) = \sqrt{2}R_1 i_1^{(m-1)}(t). \end{cases} \quad (11)$$

The equivalent circuit interpretation of (10) is illustrated in Fig. 2(a). Also in this case, it is possible to avoid series voltage sources by rewriting (10) as

$$i_k^{(m)}(t) = \frac{1}{R_0} v_k^{(m)}(t) + i_{eq,k}^{(m)}(t) \quad (12)$$

with $i_{eq,k}^{(m)} = -v_{eq,k}^{(m)}(t)/R_0$. The above equation has the dual circuit equivalent illustrated in Fig. 2(b).

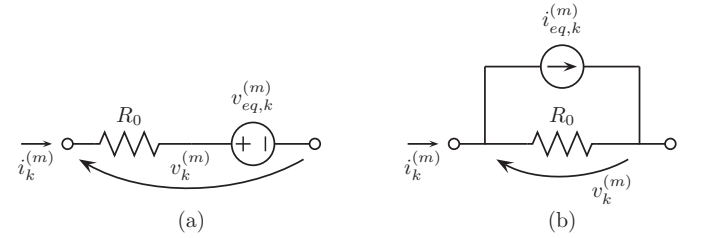

Fig. 2. Current-driven (a) and voltage-driven (b) circuit model of the perturbative SGM problem for a stochastic resistor.

The new model simply amounts to a deterministic resistor with nominal resistance, equipped with an independent source. Similar models are derived for other stochastic resistors, replacing them in the original circuit, whereas deterministic components remain unaltered. The original independent stimuli appear only in the circuit for $k = 0$, and they are set to zero otherwise (cfr. [3]).

The network is first solved once with null equivalent sources to obtain the deterministic response (step $m = 0$, $k = 0$). There is no need to solve further for $k > 0$, as both the independent stimuli and the equivalent sources are null at this stage, resulting in a null response. Next, the equivalent sources for each resistor are calculated using (11), and the circuit is simulated for each k by including the corresponding sources (step $m = 1$). The process is iterated by updating the equivalent sources with (11) until the PC coefficients of the variables of interest cease to vary within a given threshold, or a predefined number of steps is reached. It is important to remark that the solution virtually retains the same accuracy as the standard SGM, provided that a sufficient number of iterations is considered.

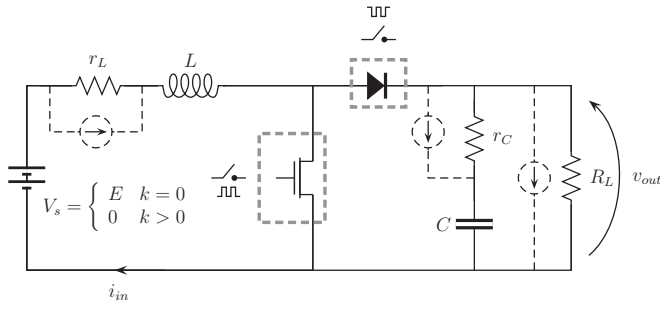

Fig. 3. Schematic of the boost converter. The dashed current sources denote the equivalent sources for the stochastic resistors in the perturbative SGM simulation. The original independent voltage source $V_s = E$ is retained only when solving for the zero-order PC coefficient, and is set to zero otherwise.

IV. NUMERICAL RESULTS

The proposed modeling approach is applied to the boost converter depicted in Fig. 3 [12]. The nominal values of the components are: $E = 20$ V, $r_L = 0.1$ Ω , $L = 5$ m Ω , $r_C = 0.5$ Ω , $C = 10$ μ F, $R_L = 20$ Ω . The switching frequency is $f_s = 10$ kHz. The load resistance R_L and the parasitic resistances r_C and r_L are considered as three independent Gaussian random variables with a standard deviation of 10% from their mean values. The circuit is implemented in Simulink, and the diode and MOS transistor are modeled as ideal complementary switches to mimic a continuous conduction mode operation [15].

In order to generate reference results, a Monte Carlo (MC) analysis with 10000 samples is performed, meaning that the original circuit is repeatedly simulated for each sample of the random resistances. For the proposed method instead, the three stochastic resistors are modeled as being deterministic in the circuit equivalent, with values equal to their nominal value, but adopting the model of Fig. 2(b), they are equipped with a parallel current source (as indicated by the dashed components in Fig. 3), which is updated through the iterations.

Fig. 4 shows the transient behavior of the input current i_{in} (top panel) and the load voltage v_{out} (bottom panel). The gray lines are a superposition of MC samples, providing a visual indication of the spread due to the variability of the resistors. The solid blue line is the average over the MC curves, whereas the dashed red line is the estimation provided by the first PC coefficient of the corresponding variables (see Section II). Fig. 5 further compares the standard deviations obtained with the two approaches. Overall, an excellent accuracy is established.

Fig. 6 shows the stochastic behavior of the spectrum of the input current at the steady state, which is the main responsible for conducted emissions [13]. The spectrum exhibits peaks at multiples of the switching frequency. The gray lines are obtained via a fast Fourier transform (FFT) of the MC samples. The average spectrum (blue line in the top panel) is compared against the PC prediction (dashed red line). The curves in the bottom panel compare the standard deviation obtained with

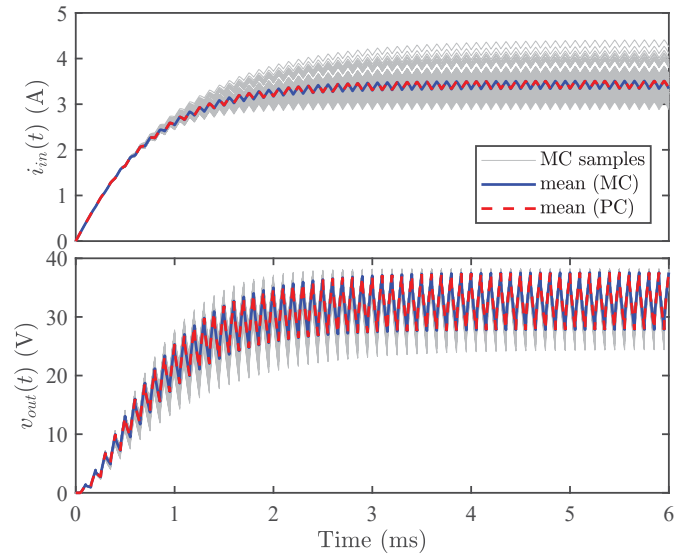

Fig. 4. Transient input current (top panel) and output voltage (bottom panel). Gray lines: MC samples; solid blue lines and dashed red lines: averages obtained from the MC and perturbative SGM simulation, respectively.

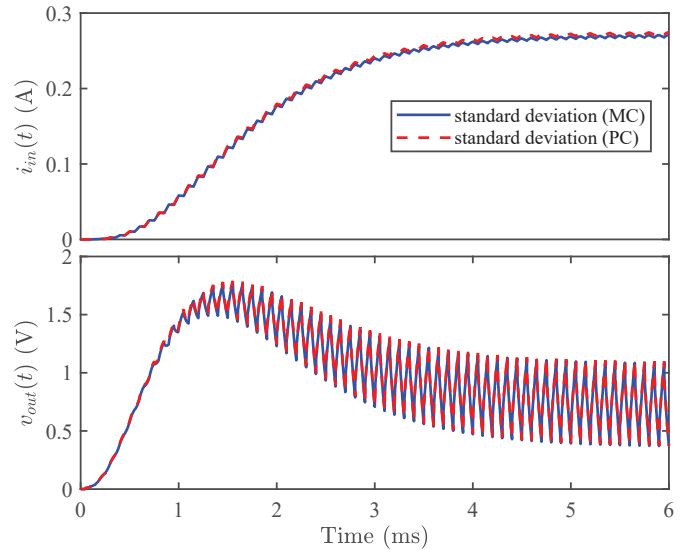

Fig. 5. Standard deviation of the transient input current (top panel) and output voltage (bottom panel) obtained with MC (solid blue line) and perturbative SGM (dashed red line).

the two techniques. It should be noted that the PC coefficients of the spectrum are readily obtained as the FFT of the time-domain coefficients, due to the linearity of the Fourier operator.

Finally, in order to assess the impact of each random variable on the variability of the spectrum, Sobol's sensitivity indices for each frequency are computed from the PC expansion of the spectrum [14]. The plot in Fig. 7 shows that the variability is largely dominated by the variation of the load resistance, whereas the impact of the parasitic resistances is marginal.

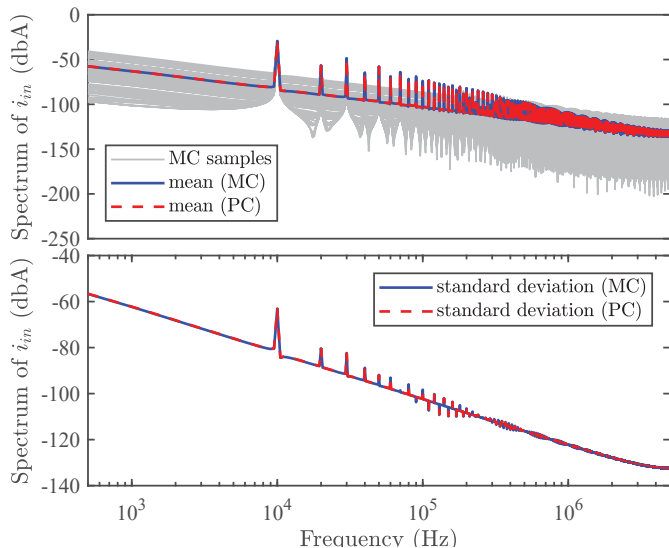

Fig. 6. Spectrum of the input current. Gray lines: MC samples; solid blue and dashed red lines: average (top panel) and standard deviation (bottom panel) from the MC and PC analysis, respectively.

The number of PC expansion coefficients for the considered application example, with $d = 3$ random parameters and expansion order $p = 2$, is $K + 1 = 10$. In this case, a fixed number of $M = 5$ iterations was considered. Therefore, the total number of deterministic simulations to be performed is $1 + M(K + 1) = 51$, as opposed to the 10000 simulations of the MC analysis. The simulation times required by MC and the perturbative SGM are 14540 s and 192 s, respectively, with the latter achieving a speed-up of about $76\times$. This is smaller than the theoretical speed-up of $10000/51 = 196\times$ due to some overhead in the update of the equivalent sources. In contrast with the newly proposed approach, the state-of-the-art SGM implementation [3] would require the development and simulation of a $(K + 1)$ -times larger circuit with coupled models for the stochastic resistors.

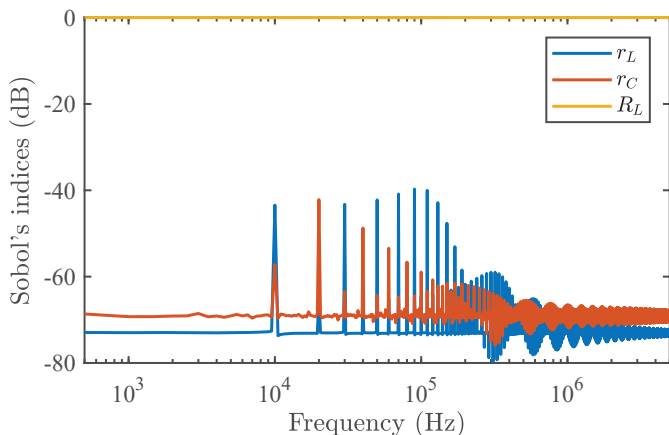

Fig. 7. Sobol's sensitivity indices (total effect) for the spectrum of the input current.

V. CONCLUSIONS

A perturbative reformulation of the SGM is discussed in this paper, which allows solving the SGM problem iteratively in a decoupled manner. This leads to a computational complexity that grows linearly with the number of PC coefficients to be determined.

Moreover, the new problem has a much simpler circuit implementation with respect to the state-of-the-art SGM models. For the case of stochastic resistors as considered in this paper, a nominal (deterministic) resistor is equipped with an equivalent independent source that is suitably updated through the iterations.

The method is expected to increasingly outperform the state-of-the-art implementations of the SGM when the number of PC expansion terms is increased. Analogous models for stochastic inductors and capacitors, as well as more extensive discussion and validations will be presented in a future work.

REFERENCES

- [1] K. Strunz and Q. Su, "Stochastic formulation of SPICE-type electronic circuit simulation using polynomial chaos," *ACM Trans. Model. Comput. Simul.*, vol. 18, no. 4, pp. 15:1–15:23, Sep. 2008.
- [2] M. R. Rufuie, E. Gad, M. Nakhla, and R. Achar, "Generalized Hermite polynomial chaos for variability analysis of macromodels embedded in nonlinear circuits," *IEEE Trans. Compon. Packag. Manuf. Technol.*, vol. 4, no. 4, pp. 673–684, Apr. 2014.
- [3] P. Manfredi, D. Vande Ginste, D. De Zutter, and F. G. Canavero, "Stochastic modeling of nonlinear circuits via SPICE-compatible spectral equivalents," *IEEE Trans. Circuits Syst. I, Reg. Papers*, vol. 61, no. 7, pp. 2057–2065, Jul. 2014.
- [4] Z. Zhang, T. A. El-Moselhy, I. M. Elfadel, and L. Daniel, "Stochastic testing method for transistor-level uncertainty quantification based on generalized polynomial chaos," *IEEE Trans. Comput.-Aided Des. Integr. Circuits Syst.*, vol. 32, no. 10, pp. 1533–1545, Oct. 2013.
- [5] D. Spina, F. Ferranti, T. Dhaene, L. Knockaert, G. Antonini, and D. Vande Ginste, "Variability analysis of multiport systems via polynomial-chaos expansion," *IEEE Trans. Microw. Theory Techn.*, vol. 60, no. 8, pp. 2329–2338, Aug. 2012.
- [6] P. Manfredi, D. Vande Ginste, D. De Zutter, and F. G. Canavero, "Generalized decoupled polynomial chaos for nonlinear circuits with many random parameters," *IEEE Microw. Wireless Compon. Lett.*, vol. 25, no. 8, pp. 505–507, Aug. 2015.
- [7] M. Ahadi and S. Roy, "Sparse linear regression (SPLINER) approach for efficient multidimensional uncertainty quantification of high-speed circuits," *IEEE Trans. Comput.-Aided Des. Integr. Circuits Syst.*, vol. 35, no. 10, pp. 1640–1652, Oct. 2016.
- [8] M. Ferber, C. Vollaie, L. Krähenbühl, J. L. Coulomb, and J. A. Vasconcelos, "Conducted EMI of DCDC converters with parametric uncertainties," *IEEE Trans. Electromagn. Compat.*, vol. 55, no. 4, pp. 699–706, Aug. 2013.
- [9] D. Xiu and G. E. Karniadakis, "The Wiener-Askey polynomial chaos for stochastic differential equations," *SIAM, Journal of Sci. Computation*, vol. 24, no. 2, pp. 619–622, 2002.
- [10] R. G. Ghanem and P. D. Spanos, *Stochastic Finite Elements. A Spectral Approach*. New York: Springer-Verlag, 1991.
- [11] C.-W. Ho, A. Ruehli, and P. Brennan, "The modified nodal approach to network analysis," *IEEE Trans. Circuits Syst.*, vol. 22, no. 6, pp. 504–509, Jun. 1975.
- [12] R. Trincherio, I. S. Stievano, and F. G. Canavero, "Steady-state analysis of switching power converters via augmented time-invariant equivalents," *IEEE Trans. Power Electron.*, vol. 29, no. 11, pp. 5657–5661, Nov. 2014.
- [13] R. Trincherio, I. S. Stievano, and F. G. Canavero, "EMI prediction of switching converters," *IEEE Trans. Electromagn. Compat.*, vol. 57, no. 5, pp. 1270–1273, Oct. 2015.
- [14] B. Sudret, "Global sensitivity analysis using polynomial chaos expansions," *Rel. Eng. Syst. Safety*, vol. 93, no. 7, pp. 964–979, Jul. 2008.
- [15] M. H. Rashid, *Power Electronics: Circuits, Devices and Applications*, 3rd ed., Upper Saddle River, NJ, USA: Prentice-Hall, 2004.