

FEM-Aided Structural Design of a Natural Fiber Composite Made Skiff

*Original*

FEM-Aided Structural Design of a Natural Fiber Composite Made Skiff / Moscoloni, Claudio; Fontana, Marco; Passione, Biagio; Cinefra, Maria; Mattiazzo, Giuliana. - ELETTRONICO. - (2018), pp. 434-443. ((Intervento presentato al convegno NAV 2018 tenutosi a Trieste (IT) nel 20 - 22 giugno 2018 [10.3233/978-1-61499-870-9-434]).

*Availability:*

This version is available at: 11583/2710465 since: 2018-07-03T14:55:06Z

*Publisher:*

IOS Press

*Published*

DOI:10.3233/978-1-61499-870-9-434

*Terms of use:*

openAccess

This article is made available under terms and conditions as specified in the corresponding bibliographic description in the repository

*Publisher copyright*

(Article begins on next page)

# FEM-Aided Structural Design of a Natural Fiber Composite Made Skiff

Claudio MOSCOLONI<sup>a,1</sup>, Marco FONTANA<sup>a</sup>, Biagio PASSIONE<sup>a</sup>,  
Maria CINEFRA<sup>a</sup> and Giuliana MATTIAZZO<sup>a</sup>

<sup>a</sup>*Politecnico di Torino, Department of Mechanical and Aerospace Engineering*

**Abstract.** In racing boat design, the research is moved to find always the best compromise between performance and safety. The present work focuses on the description of the structural design cycle used by Polito Sailing Team during the realization of its new skiff, a high-performance sailing dinghy, built mainly with natural composite material such as balsa wood and flax fiber. The whole boat was completely designed by students, according to eco-sustainable principles, to participate in a universities competition called 1001VelaCup. To determinate the sandwich composite stratification, a benchmarking of materials was made by mechanical tests run according to ASTM 3039 and 3518 regulations. A finite element (FE) model was built to evaluate the static response of the structure, aiming to obtain a safe and light hull. The fluid (sea) interaction is modeled with a linear springs system. The crew, rig and rigging loads are obtained from a one-dimensional model and hydrodynamics pressure from ISO 12215-5:2014. The outputs obtained are consistent with the physics of the problem and the stresses distribution shows that the maximum stress is in the proximity of the mast base. This work constitutes the first step to obtain a correct, reliable and innovative design tool.

**Keywords.** Finite element method, composite materials, natural materials, skiff design, structural design, lightweight structure

## 1. Introduction and state of the art

The field of yacht design requires a non negligible effort from an engineering point of view. A sailing boat is a complex system in which the elements interact each other through tangled connections [1]. Computational tools for engineering like Finite Element Method offer a powerful way to achieve practical results in terms of safety and performances, nevertheless, attention must be paid to constraints and approximations, input force and geometry selection [2]. On the other hand, experimental validation of the numerical model is needed. At date, there is limited experience concerning the structural design of a boat by advanced numerical techniques. The effort needed for the use of these methods from both the technical and computational point of view is justified only in a few cases, where the optimization of the structural design is a key issue from the performance point of view. This is the case of the aeronautical industry and the competition sailing boats. The complexity of the problem can be divided in two main issues:

---

<sup>1</sup>Corresponding Author. E-mail: [claudio.moscoloni.pst@gmail.com](mailto:claudio.moscoloni.pst@gmail.com)  
[marco.fontana.pst@gmail.com](mailto:marco.fontana.pst@gmail.com)

the implementation of non-deterministic loads and the modelling of specific constraints for the fluid interaction. The first step of this work has been the implementation of a flexible constrain to simulate the hull's heave. Once solved as shown in the following, the loads given by rig and rigging are obtained partly analytically, under simplifying hypotheses, and partly by regulations. This paper is articulated as follows: in section 2, the materials selection is discussed and their mechanical properties are analyzed. In section 3, the physical problem is presented and the constraints modelling is discussed. Section 4 reports the FEM model. In sections 5 and 6 results are discussed and conclusions are outlined.

## 2. Materials

According to the eco-sustainable principles of the whole project, *Numen*, the third boat of Polito Sailing Team, was built using natural materials in a sandwich symmetric configuration.

Sandwich stratification consists of flax fiber unidirectional (UD), fiber of s-glass UD, a core of balsa and epoxy resin in different setups for hull and deck. The main material is flax fiber in unidirectional configuration, chosen as the best compromise between the performances and the respect of eco-friendly design principles.

The sandwich's layering was a results of an optimization based on usage of flax, in terms of percent in weight, both in UD configuration and BIAx. These flax skins are properly placed from neutral plane in order to maximize the flexural stiffness. According to a conservative and safety oriented structural design the s-glass has been used as reinforcement where needed. For the determination of the mechanical properties of the selected materials, mechanical tests were performed in according to [3]

### 2.1. Production technology

Tests have been made through hand lay-up and vacuum lamination procedures. The entire process sets up the manual placement of the reinforcement layers and the matrix, epoxy SX 10 EVO with slow hardener, upon the lamination surface. Regulations ASTM 3039 [4] and ASTM 3518 [5] assigned the thickness of the stacked layers. Geometrical dimensions of the samples are given in Tab.1 with a 99% confidence interval.

	L [cm]	W [cm]	T [cm]
ASTM 3039			
S-glass 0°	27.5	1.5 ± 0.15	0.19 ± 0.01
Flax 0°	28.08 ± 0.1	1.98 ± 0.03	0.38 ± 0.02
S-glass 90°	21.1 ± 0.06	2.97 ± 0.01	0.19 ± 0.01
Flax 90°	19.47 ± 0.04	3.47 ± 0.48	0.39 ± 0.01
ASTM 3518			
Flax BIAx	29.7	2.99 ± 0.02	0.49 ± 0.01
S-glass BIAx	28.3 ± 0.04	2.99 ± 0.01	0.25

Table 1.: Geometrical Properties

Picture of a tested sample is given in Fig.1, where  $L, W$  and  $T$  are respectively the specimen's length, width and thickness.

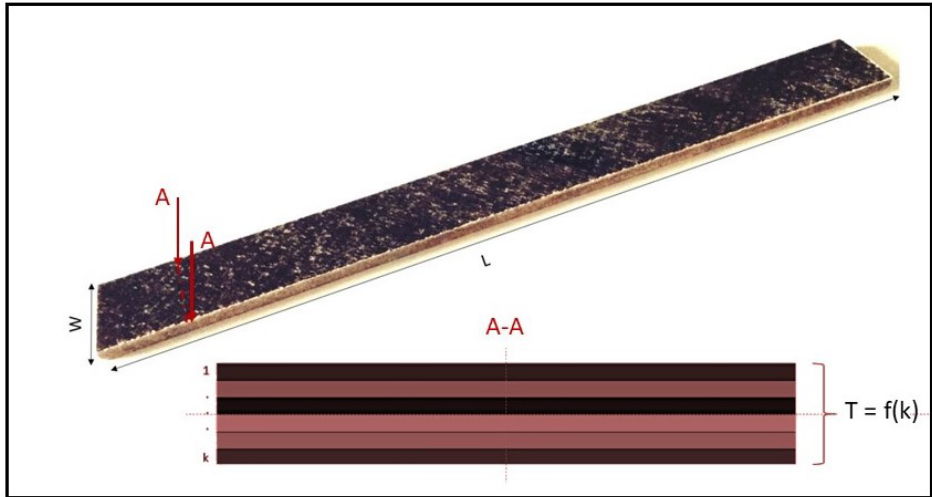

Figure 1. Sizes Overall

### 2.2. Mechanical tests

In according to regulations, tensile and shear tests have been conducted in order to determine  $E_1, E_2, \nu_{12}$  e  $G_{12}$ . The machine used for the tests was the INSTRON 8516 of the Department of Mechanical and Aerospace Engineering.

Results are shown in Tab.2 with a 90% confidence interval.

	$E_1$ [GPa]	$E_2$ [GPa]	$\nu_{12}$	$G_{12}$ [GPa]
Balsa Wood	3.740	0.056	0.488	0.138
Flax UD	$17.12 \pm 0.19$	$3.41 \pm 0.11$	0.288	$1.95 \pm 0.39$
S-glass UD	$43.68 \pm 5.37$	$9.13 \pm 2.76$	0.194	$4.89 \pm 0.21$

Table 2.: Mechanical properties

### 2.3. Sandwich characterization

The sandwich stratification was determined by an optimization loop about each layer. The final layering is symmetric, to avoid coupling-effects, and formed by two layers of biaxial flax fiber and an one layer of cross-ply S-glass fiber for each side.

As shown in Fig.2, the maximum stress obtained through experimental four-point bending test [6], equals to  $281.4 \text{ MPa}$ , is higher than the maximum stress obtained by FEA.

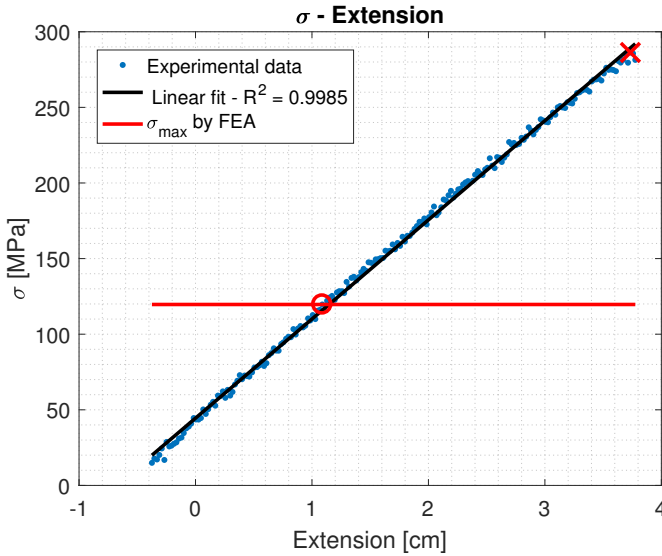

Figure 2.  $\sigma$  - Extension

### 3. Physical problem

To obtain an effective sizing of a skiff sailing boat it's necessary to take in account multiple aspects, going from the interaction between structure and fluid, to non-deterministic forces that generate a complex strain-stress state in the whole structure. In this paper the physical problem has been defined in simplified terms considering the external loads only from rig and rigging and hydrostatic pressures, achieved from regulation. The fluid-structure interaction is modelled as a yielding constrain using a system of linear springs with an adequate stiffness. The loads and constrains are shown in Fig.3.

#### 3.1. Load conditions

As described previously, the external load system is far complicated. In this paper the loads are obtained, in a first approximation, through forcing the balance in terms of vertical translation between the rig-rigging loads and the pressure obtained by ISO 12215:2014:5 regulation [7].

##### 3.1.1. Rig and Rigging Loads

Rig and rigging loads have been achieved by a streamlined beams-rods model in which the load on the mast results from the bending moment generated by the crew. Starting from these considerations, reaction forces were obtained and applied at the mast base, the charged shroud and the stay connections.

Compression load located at mast head is the outcome of balancing moment due to the crew and interaction with the sail plan [8].

$$F = \frac{1.5 \cdot RM(30)}{HCPB} + \frac{12 \cdot RM(30)}{PW} + \frac{2.5 \cdot RM(30)}{J} \tag{1}$$

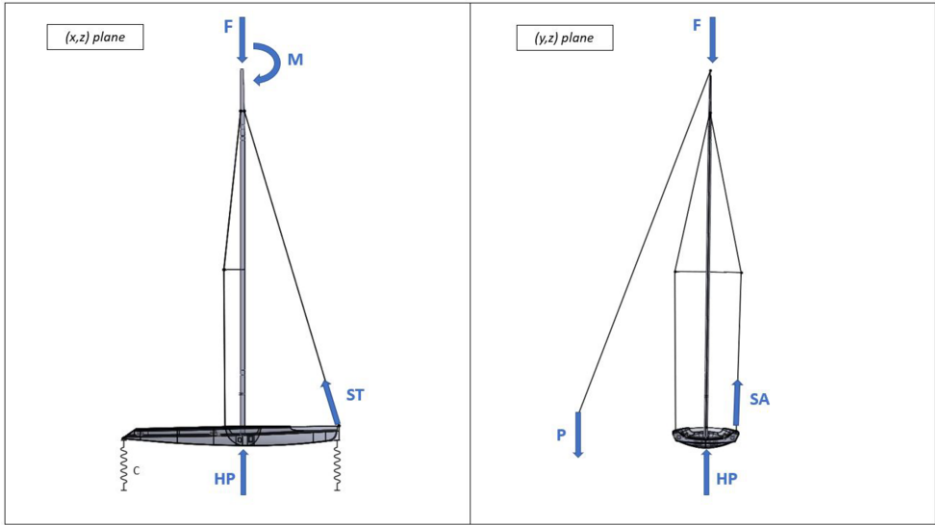

Figure 3. Physical Problem

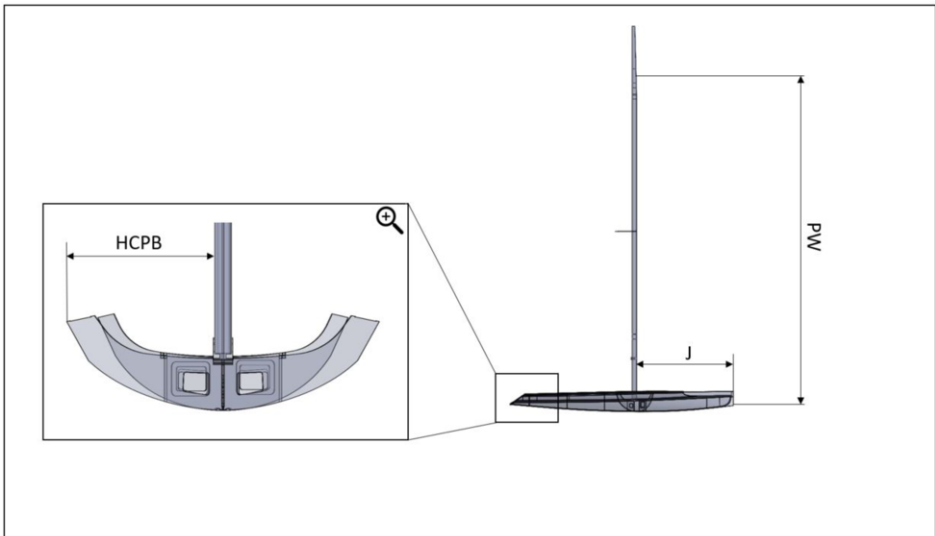

Figure 4. Characteristic dimensions

where:

- $F$  = force located at top of the mast [N];
- $RM(30)$  = righting moment at  $30^\circ$  heeling angle [Nm];
- $PW$  = height of mainsail tip from the water line [m];
- $J$  = foretriangle base length [m];
- $HCPB$  = half distance of the chainplates [m].

Sizes  $HCPB$ ,  $PW$  and  $J$  are defined as shown in Fig.4.

### 3.1.2. Hydrodynamic Pressure

As previously stated, the hydrodynamic pressures were obtained by ISO 12215:2014:5 regulation [7]. The ISO prescribes a constant speed of 4.95 knots for a D design category (sheltered waters). The hull is discretized in panels according to an adequate shape parameter that let to achieve the design pressure exerted on each panel of the bottom hull. The trend of the pressure in terms of the coordinate normalized on the water line is shown in Fig.5.

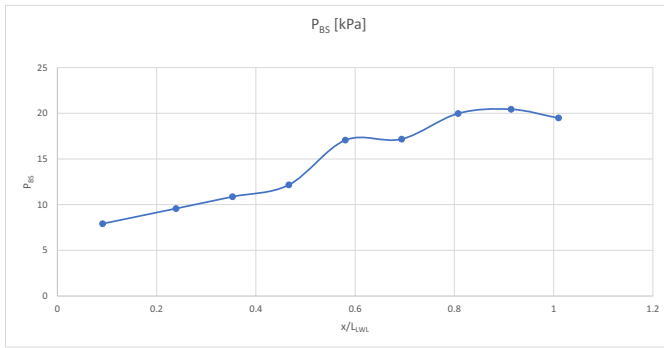

Figure 5. Pressure on the hull by ISO 12215:2014:5 regulation

### 3.2. Constrains

In order to allow the heave DOF, a non-zero displacement in vertical direction is required. From a structural design point of view, the effect of fluid interaction is described by an elastic restoring force that has been modelled as a yielding constrain. Consequently, a system of linear spring is considered. The stiffness of this elastic behaviour was obtained by properly handle the equation of motion of the floating body. Subject to external hydrodynamic forces:

$$(m + a)\ddot{z} + b\dot{z} + cz = F_{ext} \tag{2}$$

The so called hydrostatic stiffness [9] is:

$$c = \rho g A_{WP} \tag{3}$$

Where  $\rho, g$  and  $A_{WP}$  are respectively the sea water density, the gravity acceleration and the waterplane area. The  $c$  so obtained is the sum of linear spring's stiffness.

## 4. Modelling

In order to calculate the static response of a complex structure was necessary to translate the previously exposed problem into a finite element formulation. For this aim a FEM model was created modelling the shapes and geometries, loads and boundary conditions and the composite materials adopted.

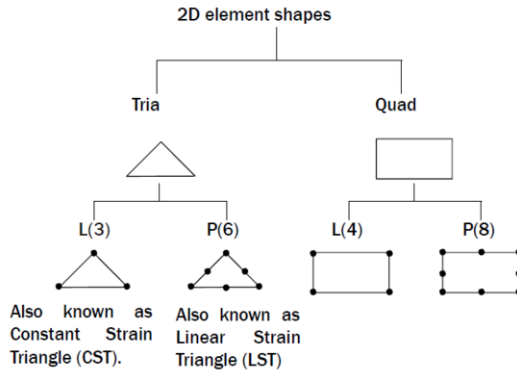

Figure 6. Type of 2D elements

By a numerical point of view, CQUAD4, CTRIA3 and CTRIA6 shell elements, summarized in Fig.6, have been used for the structure, a 1D model of ROD and BEAM elements to compute the external loads given by rig and rigging, lastly system of 0D spring elements to simulate the interaction with fluid.

To better describe and compute the boat’s behaviour, since the particular geometry configuration, characterized by small angles, and the usage of non conventional materials, the first intention was to use parabolic shell elements. However, because of the very high computational cost, a tradeoff analysis was performed, testing different mesh setups, as show in Tab.3.

Elements	Cases			
	A	B	C	(D)
CELAS1			✓	✓
CTRIA3	✓			✓
CTRIA6		✓	✓	✓
CQUAD4	✓			✓
CQUAD8		✓	✓	
RAM required [MB]	3305	15689	73317	5332

Table 3.: Mesh Cases

Hence, on the basis of previous observations, the case D, consting of 562’488 elements, resulted the best setup.

#### 4.1. FEM Formulation

The generic displacement of a 2D problem can be written as:

$$u(x, y, z) = \sum_{n=0}^N z^n u^n \tag{4}$$



In terms of finite elements:

$$u_i = N_i \cdot q_i \tag{5}$$

where  $q_i$  is the generic nodal DOF of the element and  $N_i$  the generic term of the shape functions matrix. The inner displacement can be described as a linear or 2nd order function of the nodal degree of freedom, depending on the polynomial degree obtained by the Lagrange’s triangle. With the increasing of the polynomial also the solution accuracy increases. This confirms the differences between the RAM usage reported in Tab.3.

#### 4.1.1. Spring Elements

In order to simulate the interaction between fluid (sea) and structure, it chosen a system of linear springs characterized by a 0D spring element called CELAS1. This is a scalar element that implement the classical equation of an elastic force:

$$F = c(u_2 - u_1) \tag{6}$$

where  $c$  is the stiffness coefficient, obtained from Eq.3, and  $u_i$  is a generic degree of freedom. In our case this scalar element is a connection whit the ground in order to simulate a flexible constrain.

#### 4.2. Linear static analysis

In order to perform the structural sizing, a linear static analysis is required. To obtain the governing equation it is necessary to impose the stationarity of a variation of a generic functional, as shown in [10]. In general, imposing the stationarity of a functional  $\Pi$  based on displacement formulation permits to obtain the Virtual Working Principle (VWP) in the form of Virtual Displacement Principle (VDP):

$$\delta\Pi = 0 \tag{7}$$

$$\delta L_{int} = \delta L_{ext} \tag{8}$$

Replacing expressions of strains and stresses in terms of nodal degrees of freedom, the static problem’s expression is obtained:

$$\mathbf{K} \mathbf{u} = \mathbf{F} \tag{9}$$

where  $\mathbf{K}$  is the matrix of global stiffness obtained through the assembly of the local ones.

### 4.3. Implementation tools

The whole model has been implemented in a CAE environment in which the capability of defining the sandwich both as integral laminate, and a ply structured material is allowed. In this work, the sandwich of *Numen* sailing boat was built using a reverse assignment technique of the properties to finite elements. In this way it is possible to consider

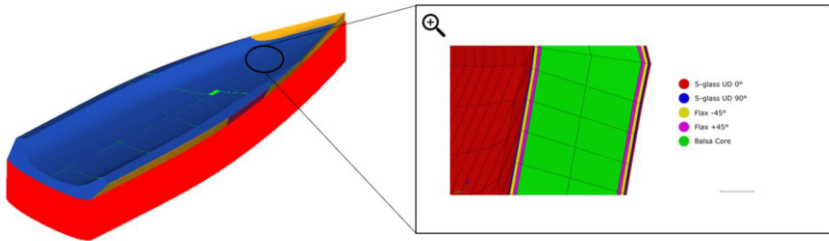

Figure 7. In CAE visualization of sandwich

individually each layer as shown in Fig.7, this solution gives the possibility for further optimization.

## 5. Results

The outputs obtained from the static analysis are consistent to the physics of the problem. In fact, the distribution of stresses shows that the maximum values are in proximity of the mast base equal to about 120 MPa as shown is Fig.8. As previously exposed, the breaking bending load obtained by tests for this sandwich configuration is about 281.4 MPa, this returns a safety factor of 2.3.

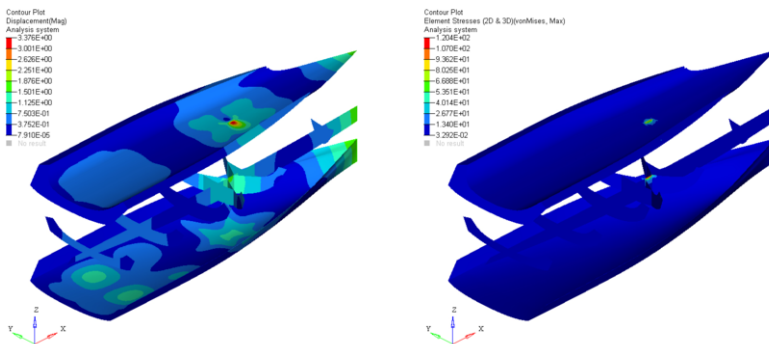

Figure 8. VonMises stresses and displacement fields

## 6. Conclusion

The outputs outcome are consistent with physics of the problem and the maximum stress allowed is lower than value obtained by experimental tests. Although the results are encouraging, a calibration is necessary to use the suggested model as a design and optimization tool. For this purpose, the whole boat was fitted with strain gauges to validate the proposed model. Thanks to this work, it will be possible to obtain an innovative, efficient and reliable design tool for the future boats; it can be used to pursue a synthesis of performance optimization and use of sustainable materials.

## Acknowledgements

The authors want to acknowledge all the members of Polito Sailing Team who worked at this project, the facilities of the Department of Mechanical and Aerospace Engineering of Politecnico di Torino and Altair Engineering s.r.l to support the project with a sponsorship program.

## References

- [1] A. Quarteroni N. Parolini. Modelling and numerical simulation for yacht engineering. In *Proceedings of the 26th Int. Symp. On Naval Hydrodynamics*, 2007.
- [2] DNV. Dnv rules for high speed, light craft and naval surface craft, "direct calculation methods", 2015. Pt 3, Ch 9.
- [3] DNV. Dnv rules for high speed, light craft and naval surface craft, hull structural design, fibre composite and sandwich construction, 2018. Pt 3, Ch 4.
- [4] ASTM International. Test method for tensile properties of polymer matrix composite materials, 2014.
- [5] ASTM International. Test method for in-plane shear response of polymer matrix composite materials by tensile test of a 45 laminate, 2013.
- [6] ASTM International. Test method for core shear properties of sandwich constructions by beam flexure, 2016.
- [7] UNI EN ISO. 12215-5:2014, small craft – hull construction and scantlings – part 5: Design pressures for monohulls, design stresses, scantlings determination, 2014.
- [8] Mitchell C J. Rigging loads on the yacht 'new zealand' and rig design formulae. *RINA Transaction*, 1993.
- [9] W.W. Massie J.M.J. Journe. *Offshore Hydromechanics*. First edition, 2001.
- [10] C. Felippa. *Advanced Variational Methods In Mechanics*. 2013.