

Nanomaterials for the abatement of pharmaceuticals and personal care products from wastewater

Original

Nanomaterials for the abatement of pharmaceuticals and personal care products from wastewater / Freyria, Francesca Stefania; Geobaldo, Francesco; Bonelli, Barbara. - In: APPLIED SCIENCES. - ISSN 2076-3417. - 8:2(2018), p. 170. [10.3390/app8020170]

Availability:

This version is available at: 11583/2700865 since: 2018-02-21T11:20:30Z

Publisher:

MDPI AG

Published

DOI:10.3390/app8020170

Terms of use:

This article is made available under terms and conditions as specified in the corresponding bibliographic description in the repository

Publisher copyright

(Article begins on next page)

Review

Nanomaterials for the Abatement of Pharmaceuticals and Personal Care Products from Wastewater

Francesca Stefania Freyria ^{1,2,3} , Francesco Geobaldo ¹ and Barbara Bonelli ^{1,2,*} 

¹ Department of Applied Science and Technology, Politecnico di Torino, Corso Duca degli Abruzzi 24, 10129 Turin, Italy; francesca.freyria@polito.it or freyria@mit.edu (F.S.F.); francesco.geobaldo@polito.it (F.G.)

² INSTM Unit of Torino-Politecnico, Corso Duca degli Abruzzi 24, 10129 Torino, Italy

³ Department of Chemistry, Massachusetts Institute of Technology, Cambridge, MA 02139, USA

* Correspondence: barbara.bonelli@polito.it; Tel.: +39-011-090-4719

Received: 19 December 2017; Accepted: 15 January 2018; Published: 25 January 2018

Abstract: In this short-review, the most common types of both pharmaceutical and personal care products (PPCP, a class of “emerging pollutants”) are considered, as well as some of the most frequent methods for their removal that envisage the use of nanomaterials. The nanomaterials used in conservative methods (namely, reverse osmosis, nanofiltration and adsorption) are basically nanoporous solids. Non-conservative methods, which include photocatalysis and Fenton reaction, are currently considered more promising than conservative ones, as the former allow the (at least) partial degradation of the original molecules into more biodegradable by-products, which can be further abated by subsequent biological treatments, whereas the former are not efficient for the removal of small quantities of pollutants and have to be regenerated.

Keywords: emerging pollutants; PPCPs; photocatalysis; nanomaterials

1. Introduction

Although pharmaceuticals and personal care products (PPCPs) have been used since the end of the 19th century, only in the last two decades the concern for their (post disposal) persistence in the environment has been raised, since they are bioactive species by showing either short or long term toxicity [1–3].

Pharmaceutical products are drugs used to treat both human and animal illnesses, whereas personal care products are mainly used in cosmetics [4]. After consumption and use, low concentrations of PPCPs are continuously introduced in several ecosystems (soil, groundwater and fresh water) through sewage and waste water treatment plants (WWTPs), and finally they are found in rivers and in the surrounding environment [1,4,5].

Their very low concentration, ranging from a few ng L⁻¹ to µg L⁻¹, gives rise to a phenomenon known as micro-pollution, which makes difficult their detection, analysis and degradation in wastewater treatment plants [1]: usually, the latter are not designed and built to treat such low concentrations, mainly due to a lack in both discharge guidelines and in environmental quality standards [1,6].

Due to the availability of new (sensible and precise) analytic techniques, including liquid and gas chromatography–mass spectroscopy [6,7], able to measure concentrations as small as nanograms, it is now possible to detect and characterize such water micro-pollutants. The latter are also called emerging contaminants (ECs), because data concerning their transport, fate, toxicity and tolerated concentration in water bodies are not completely available [4].

ECs are essentially either naturally occurring or synthesized substances that interfere with the functioning of endocrine systems and result in unnatural responses of the organisms. For such compounds, regulations are still missing: ECs could be matter of future regulations, depending

on the results of research concerning their potential effects on human health and the availability of data on their occurrence in the environment. Some of these ECs do not need to be persistent to be (potentially) harmful, since they are continuously introduced into the environment and so, when degraded, are soon replaced.

ECs include not only PPCPs and steroid hormones, but also surfactants and pesticides [1]. Among these, PPCPs can easily dissolve in water, with high persistence due to their low volatility at atmospheric temperature and pressure and low biodegradability.

Moreover, their effects differ from those of other contaminants, because drugs and their metabolites are on purpose designed and synthesized to interact with cells. Therefore, when dispersed in the environment, they can more easily react with non-target organisms [7]. Especially antimicrobials, like antibiotics, are compounds that destroy or obstruct microbe proliferation.

Antibiotics are used to treat infectious diseases in human beings or animals and to preserve food (under the American Food, Drug and Cosmetic Act) [8,9]. Recently, their use in husbandry has been restricted, mainly in EU and USA, since their proliferation to prevent disease or spur growth in livestock and aquaculture has created alarms for human resistance to microbes [10–12]. All this notwithstanding, the production of antimicrobials is expected to increase up 67% by 2030, especially in developing countries, including Brazil, Russia, India, China, and South Africa (Figure 1) [2,11,13].

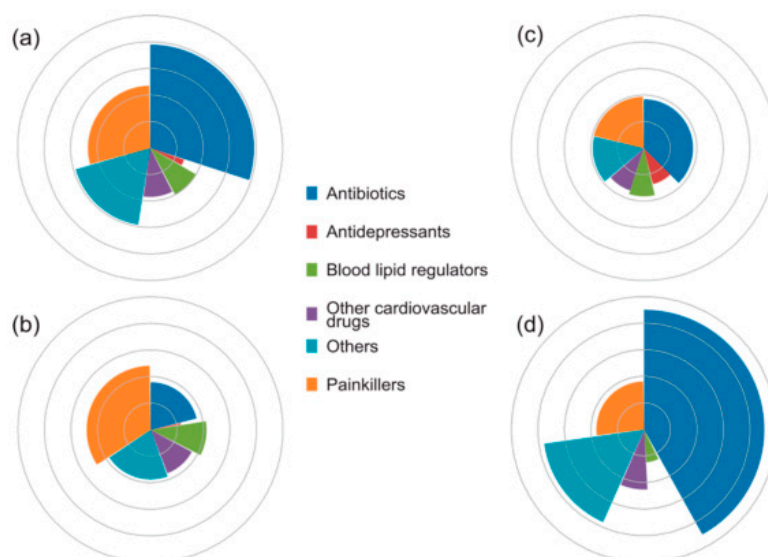

Figure 1. According to reference [2] *: Relative frequency of detection and median concentration of pharmaceuticals in receiving waters: (a) global; (b) Europe; (c) North America; and (d) Asia. (The circumference of each fan is scaled by the relative proportion of detections. Each point outward on the radial axis represents 10^y of the median concentration in ng L^{-1} . For example, the innermost circle represents 10^1 ng L^{-1} ; the second represents 10^2 ng L^{-1} , etc.). * pubs.acs.org/doi/full/10.1021/es3030148, further permissions related to the material excerpted should be directed to the ACS.

To date, several studies report the presence of pharmaceutical and endocrine disrupting compounds (EDCs) either in raw water for drinking use or in tap water for drinking use [2,14–19].

This review will firstly focus on the origin and fate of PPCPs (Table 1) and then on the methods envisaging the use of nanomaterials (NMs) to remove PPCPs from wastewater (Table 1).

Table 1. Pharmaceuticals and personal care products (PPCPs) and emerging contaminants (ECs) commonly detected in water bodies.

Main Categories	Families	Examples
Drugs and Pharmaceuticals	antibiotics/antibacterials	amoxicillin, metronidazole, ofloxacin
	steroids	estrone, 17 β -estradiol, testosterone
	β -blocker	propranolol, salbutamol, atenolol
	nonsteroidal anti-inflammatory drugs (NSAID)	aspirin, ibuprofen, naproxen, ketoprofen
	antiepileptic/anticonvulsants	gabapentin, carbamazepine
	antidepressant/hypnotic	diazepam, venlafaxine, amitriptyline, dosulepin, meprobamate
	analgesic	morphine, propoxyphene, paracetamol
	hypertension	valsartan
	lipid regulation	bezafibrate, simvastatin, clofibrilic acid
	erectile dysfunction	sildenafil
Stimulant and generally illegal drugs	hallucinogen	3,4-Methylenedioxyamphetamine (MDMA), 3,4-Methylenedioxy-N-ethylamphetamine (MDEA), 3,4-Methylenedioxyamphetamine (MDA)
	stimulant	amphetamine, cocaine, benzylpiperazine
	human indicator	caffeine, nicotine
Personal care products	preservative	methylparaben, propylparaben
	sunscreen agent	1-benzophenone, homosalate
	disinfectants/antiseptic	chloramines, chlorine, chlorine dioxide, chlorhexidine digluconate
	fragrances	musk xylol, tonalide
Pesticides/Herbicides	organohalogenated compounds	Dichlorodiphenyltrichloroethane (DDT), lindane, vinclozolin, clopyralid
	nitrogen containing	simazine, phenylurea

2. Source, Fate and Effects of Selected PPCs

The following PPCPs, which are recognized to be dangerous or considered possibly dangerous to humans, animals and the environment will be considered here: antibiotics; non-steroidal anti-inflammatory drugs; anti-hypertensives; anti-depressants; hormones and endocrine disruptive compounds.

Antibiotics (ABs) found in the environment have an anthropogenic origin: they are usually related to either human therapeutic usage (entering the environment through municipal wastewater) or intensive animal agriculture usage [4].

So far, ABs are recognized to have potential effects on both human health and the environment. The use in animal agriculture is indeed the major source of ABs, since they are used not only for therapeutic purposes, but also for prevention and sub-therapeutic use to improve feed efficiency and weight gain of the animals. Most of the ABs (ca. 90%) is indeed excreted back to the environment by animals in a partially metabolized form, which depends on the parent AB. Some of the ABs, like sulfonamides, are stable to degradation, in both biotic and abiotic conditions, and are found in surface waters; sediments; municipal wastewaters; animal waste lagoons and underlying groundwater.

Some of the ABs used for animals are similar to those used for humans like, for instance, tylosin, an AB used as a feed additive in animal agriculture, which has a human equivalent in erythromycin (Figure 2). The issue concerning these two molecules is that if microbes become resistant to tylosin, they could be resistant to erythromycin as well.

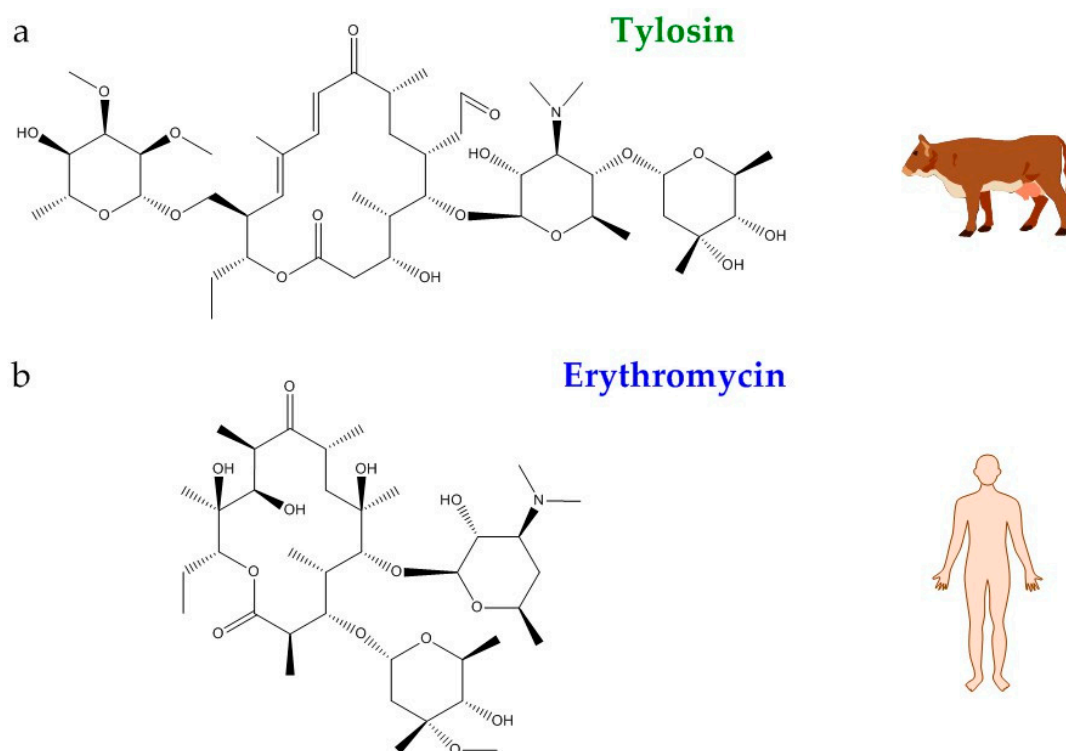

Figure 2. Molecular structure of (a) Tylosin, an antibiotic used in husbandry; (b) Erythromycin, an antibiotic used for human beings.

Non-steroidal anti-inflammatory drugs (NSAIDs, Table 1) are highly consumed drugs with analgesic, antipyretic and anti-inflammatory effects: they are found in WWTPs (in concentrations up to $\mu\text{g L}^{-1}$) and in surface waters (in concentrations of ng L^{-1}). Some of them, like aspirin, naproxen, ibuprofen, etc. are also reported in drinking water [20].

Antihypertensive drugs are able to lower blood pressure by different means, and include diuretics, angiotensin-converting-enzyme ACE inhibitors, calcium channel blockers, beta-blockers and angiotensin II receptor antagonists. Usually, beta blockers (metoprolol, atenolol and propranolol), are the most frequently reported drugs in surface water (in concentrations up to tens of ng L^{-1}), ground water, and sometimes drinking water.

Antidepressant drugs used for psycho-therapeutic use have been found in several types of fish and, moreover, have showed to be able to alter their behavior (activity, boldness and sociality) [21].

Hormones and EDCs may have either natural or anthropogenic origin and could mimic or interfere with body hormones. They can be found in both municipal waste water and waste water coming from animal agriculture: both types of source are not equipped with plants able to remove small amounts of these compounds, which are finally released to the environment. EDCs can for instance have an impact on the reproductive system of fishes and may improve their vulnerability to infectious diseases, causing an ultimate decline in fish population [22,23].

3. Removal of PPCPs by Conservative Methods Envisaging the Use of Nanomaterials

Non-reactive (conservative) methods imply the removal of the pollutant. The best results with micro-pollutants like PPCPs are usually obtained with either membrane technology (i.e., by reverse osmosis (RO) or nanofiltration (NF)) or adsorption [6]. RO is a method based of a semipermeable membrane able to remove certain ions and particles from a liquid stream. NF is a similar treatment, based on a membrane, but giving a coarser filtration without removing minerals, which are otherwise removed during the RO process.

RO and NF are particularly useful methods for the removal of micro-pollutants from drinking water, though there is still some lack of knowledge about their actual performance, which is influenced by several factors [6,24,25], such as the selectivity of organic and inorganic compound removal, salt permeability, pressure and temperature, recovery and feed water concentration. RO membranes are very energy intensive, but the occurrence of pore sizes in the 1.0–5.0 nm range may lead to more than 90% separation of organic molecules from the liquid phase.

NF membranes have larger pores (5.0–10 nm range) with respect to RO membranes and show a good performance only for big molecules, like pesticides, whereas they do not remove small molecules, such as ions. Generally, the rejection efficiency (and thus the separation performance) of a membrane is influenced both by mechanisms of size exclusion (molecular sieving) and type of sorption interactions at the liquid–solid interface (van der Waals forces, dipole–dipole forces, etc.).

The sieving effect, with the related mass-transfer phenomena occurring during diffusion and separation, controls the performance of RO membranes, whereas the type of sorption interaction controls that of NF membranes.

A study concerning the removal of EDCs showed that RO membrane efficiency increases with the molar mass of the target species if the latter are neutral molecules [26], whereas the efficiency of NF membranes increases with the charge and the molar mass of ionic compounds [27]. During membrane operation, some deposition phenomena at the membrane surface may occur that, in some cases, may lead to an improved separation efficiency of the membrane, whereas in other cases may lead to undesired fouling phenomena that have to be taken into account [26,28,29].

Polyamide NF/RO cationic membranes have been used for the rejection of 11 compounds including both EDCs and other pharmaceutical active compounds (PhACs) [30]. Two types of membranes were considered, namely a polyamide membrane and a cellulose acetate membrane. The former exhibited a better performance in terms of rejection of the selected compounds, but retention was only in the 57–91% range. It was found that the two most common ways adopted to evaluate the membrane rejection properties (i.e., molecular weight cut-off and salt rejection) were not appropriate to provide quantitative information for EDC/PhAC rejection by NF/RO membranes. As a whole, molecular weight exclusion controlled the rejection in polyamide membrane, whereas polarity mostly controlled rejection in cellulose acetate membrane.

As a conclusion [30], each present (and future) material adopted in NF/RO membranes will exhibit different trends for the rejection of micro-pollutants depending on the physico-chemical properties of the target compounds.

Activated carbons (ACs) and other adsorbents, including naturally occurring materials (wood, keratin) are considered as NMs reference for the separation of organic pollutants. It is generally acknowledged that sorption kinetics are controlled by mass-transfer phenomena at the liquid/solid interface, with retention being controlled by the sorbent/sorbate properties [31]. Therefore, the type of interaction (strong or weak van der Waals forces) and the hydrophilic/hydrophobic properties of the adsorbent are two crucial factors.

EDCs sorption on such kinds of nanoporous solids depends on both the molecule size and charge density [26,32,33]. The main drawbacks of this method, finally hampering an actual large-scale application, are the competitive adsorption of other species present in water, like natural organic matter (NOM, mainly constituted by humic and fulvic acids) and the fouling effect due to the presence of xenobiotic compounds, such as surfactants, which lead to pore blockage and lower retention [34].

A clear example is given by a literature study reporting the sorption of 17 β -estradiol onto granular ACs that was reduced by three orders of magnitude in the presence of other organic compounds in both natural waters and secondary treated wastewater [6].

Another issue related to adsorption method is the disposal of the adsorbent after its use, which is complicated by the fact that the (initially) diluted organic pollutants have been transferred to the solid from the liquid phase and have been finally concentrated in the adsorbent.

For the above reasons, many efforts are currently underway to develop (efficient) non-conservative methods, where the PPCPs are converted into less dangerous and more biodegradable by-products, if not completely mineralized.

4. Removal of PPCPs by Non-Conservative Methods Envisaging the Use of Nanomaterials

4.1. Photocatalysis and Other Advanced Oxidation Processes

According to the literature, the non-conservative methods that are actually able to efficiently remove PPCPs are mainly based on advanced oxidation processes (AOPs).

AOPs generally imply the in-situ production of highly reactive species (i.e., H_2O_2 , $\text{OH}\cdot$, O^- , O_3) that allow the degradation of refractory organic pollutants into biodegradable compounds. Rather than stand-alone methods, AOPs are really effective when used either before or after biological treatments.

AOPs may imply the use of nanomaterials (NMs) as either catalysts or photocatalysts, which improve the selective removal of the target pollutant [35,36].

As far as PPCP removal by AOPs is concerned, mineralization of the PPCPs is not necessarily achieved, with a consequent release into the environment of by-products that are indeed more biodegradable (and less toxic) than the original drug. In those cases, a biological post-treatment step may be feasible.

The most suitable AOPs for PPCP removal are heterogeneous photocatalysis, ozonation and Fenton (or Fenton-like) reaction. While the first surely implies the use of NMs (like photocatalytic nanoparticles or nanoporous materials), the other two may not.

A photocatalyst is a semiconductor where electrons are promoted from the valence band (VB) to the conduction band (CB), after absorbing photons with higher energy than the semi-conductor band gap energy (Figure 3). Photocatalysts can be activated by either simulated or natural light. The generated holes (h^+) can either oxidize adsorbed water molecules (or OH^- ions) and produce OH radicals or directly oxidize the adsorbed contaminants. The electrons transferred to the conduction band can react either with oxygen (O_2) dissolved in water (forming a superoxide radical ion O_2^-) or directly with the contaminant at the surface. The reaction efficiency is driven by catalyst concentration, pH, water composition, wavelength and intensity of radiation.

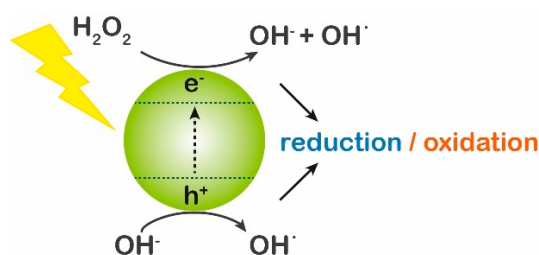

Figure 3. Sketch of a photocatalytic nanoparticle under illumination.

As a photocatalyst, TiO_2 is inexpensive, non-toxic, photochemically stable and commercially available in several crystalline forms and with different particle sizes and morphologies. Moreover, by different methods, it is also possible to obtain TiO_2 with a high surface area and relatively large pores, allowing a facile reactant/product diffusion [37].

TiO_2 , and in particular Degussa P25 (hereafter referred to as P25) is universally considered one of the most efficient photocatalysts for the abatement of several pollutants including PPCPs, followed by ZnO . The superior photocatalytic performance of P25 is mostly ascribed to the peculiar physico-chemical features of its crystallites, where the two crystalline phases anatase and rutile occur in an 80:20 weight ratio [37]. The peculiar nanostructure of P25 favors the electron/hole separation, lowering their recombination frequency.

The behavior of ZnO was even more promising in the case of the photocatalytic abatement of sulfamethazine (an antibacterial agent) [38] and of the antibiotic chloramphenicol [39]. ZnO also showed good ability to completely degrade the ABs amoxicillin, ampicillin and cloxacillin in 3 h with a chemical oxygen demand (COD) and a dissolved organic carbon (DOC) removal of 23.9% and 9.7% respectively [40]. ZnS nanoparticles were applied as a photocatalyst to remove some β -lactam antibiotics with a degradation yield of 82–100% in 2 h at pH 4.5 [41].

As far as TiO₂ water suspensions are concerned, some parameters like the pollutant concentration, pH, light wavelength and intensity, the addition of other oxidants (like H₂O₂) and the type of water matrix are crucial. In particular, pH influences the surface charge of TiO₂, and thus organic pollutant adsorption, a step that markedly influences their photocatalytic degradation. The surface charge is related to the size of the particles. Generally, for P25 with a particle diameter ~25 nm, the pH at the point of zero charge (pH_{PZC}) is 6.9, which shifts to more basic values for smaller particles [42].

As adsorption of the target pollutants is a crucial step, the nature of the aqueous matrix is also important, due to the simultaneous presence of other species like carbonates, humic acids or dissolved gases, which may lead to competitive adsorption phenomena, lowering the final photocatalytic efficiency. The degradation of amoxicillin, ampicillin and cloxacillin antibiotics in water solution (Figure 4) under UV radiation (>300 nm) in presence of TiO₂ was higher at pH 11, whereas complete degradation was reached at pH 5 after addition of H₂O₂ [43].

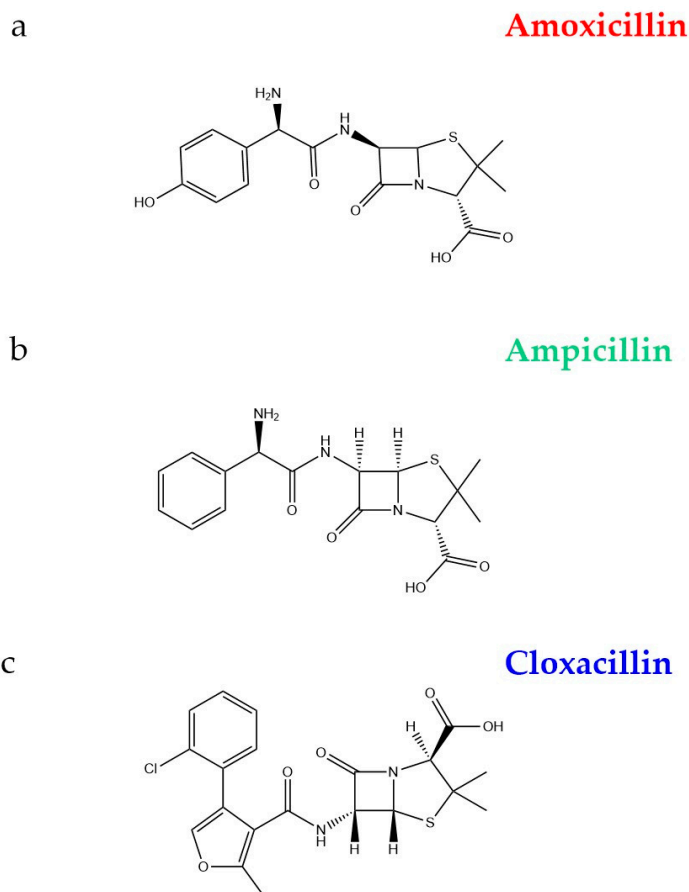

Figure 4. Molecular structure of some antibiotics (a) Amoxicillin; (b) Ampicillin; (c) Cloxacillin.

Different TiO₂ nanomaterials may have different adsorption capacities towards different pollutants. This has been clearly shown in a paper where the photocatalytic degradation (under simulated solar irradiation) of both clofibric acid and carbamazepine (two pharmaceuticals with different therapeutic effects) and of two contrast agents (iomeprol and iopromide) (Figure 5) was studied in aqueous

suspensions containing either P25 or Hombikat UV100 [44], whose textural properties are reported in Table 2.

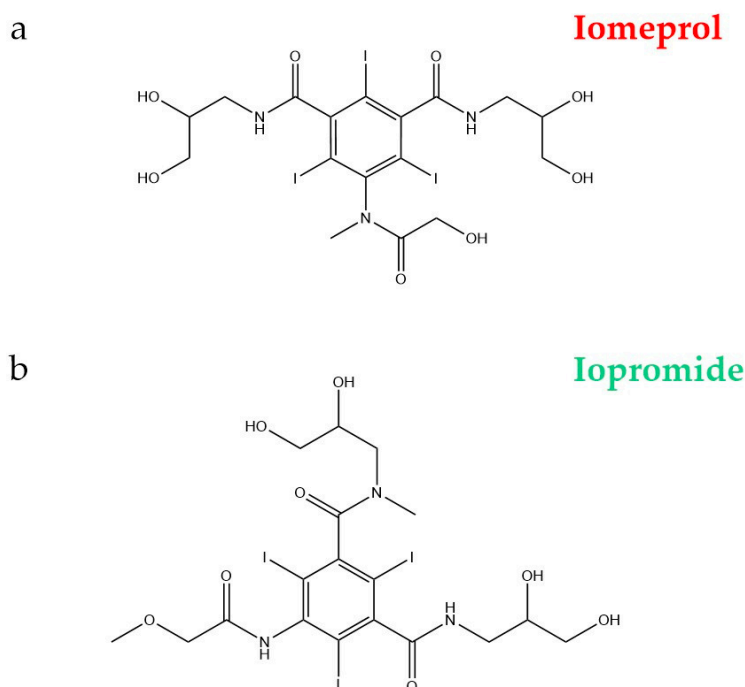

Figure 5. Molecular structure of two contrast agents: (a) Iomeprol; (b) Iopromide.

Table 2. General textural properties of TiO₂-based photocatalysts. * particles size based on TEM images and/or Scherrer calculation. Adapted from [44].

Characteristics	P25 (TiO ₂)	Hombikat UV100	Mesoporous Titania (TiO ₂)
Crystallographic phase (<i>w/w</i>)	75 ± 5% anatase 25 ± 5% rutile	100% anatase	100% anatase
Diameter of particles (nm) *	15 ± 30	<10	<20
Specific surface area (BET area, m ² g ⁻¹)	60 ± 10	>250	150 ± 40

The results showed the better photocatalytic activity of P25 towards the degradation of clofibrac acid and carbamazepine. Hombikat UV100 was instead more effective towards the degradation of iomeprol, likely due to a higher adsorption of the latter molecule at the surface of that solid. Possible degradation products were also identified and quantified: with clofibrac acid, several aromatic and aliphatic degradation products were detected, and a possible multi-step degradation scheme was proposed (Figure 6).

Moreover, a TiO₂ photocatalyst-based process showed a good ability to remove up to 68% chlorhexidine digluconate (CHD, an antiseptic compound), in 1 h at 25 °C with a substrate-to-catalyst ratio of 2.5:1 under UV light at basic pH [45].

When micro-pollutants like PPCPs are concerned, the use of high surface area TiO₂ may help their adsorption. In this respect, mesoporous TiO₂ can be obtained by different methods, including hard and soft templates and sol-gel methods [37].

Some works report the photocatalytic performance of mesoporous TiO₂ where the higher porosity and higher specific surface area should play a prominent role: for instance, Zr-doped mesoporous TiO₂ was tested for the degradation of ibuprofen and other (mainly anti-inflammatory) pharmaceuticals [46]. It was found that the material shows improved adsorption of the pollutants from the solution and high initial photocatalytic activity. In the adopted experimental conditions, however, the rapid formation of intermediates and of some polymeric compounds led to decreased activity in following cycles. pH was found to deeply affect the photocatalytic activity, which increased by a factor of six when pH decreased

from nine to two. According to the authors, the presence of surface Zr led to a more hydrophobic material, with a higher affinity of non-polar molecules. Ibuprofen is a weak acid ($pK_a = 4.4$) and at low pH mostly occurs as undissociated molecules that can absorb at the surface by H-bond through carboxylic groups. The (more hydrophilic) intermediates formed were instead desorbed.

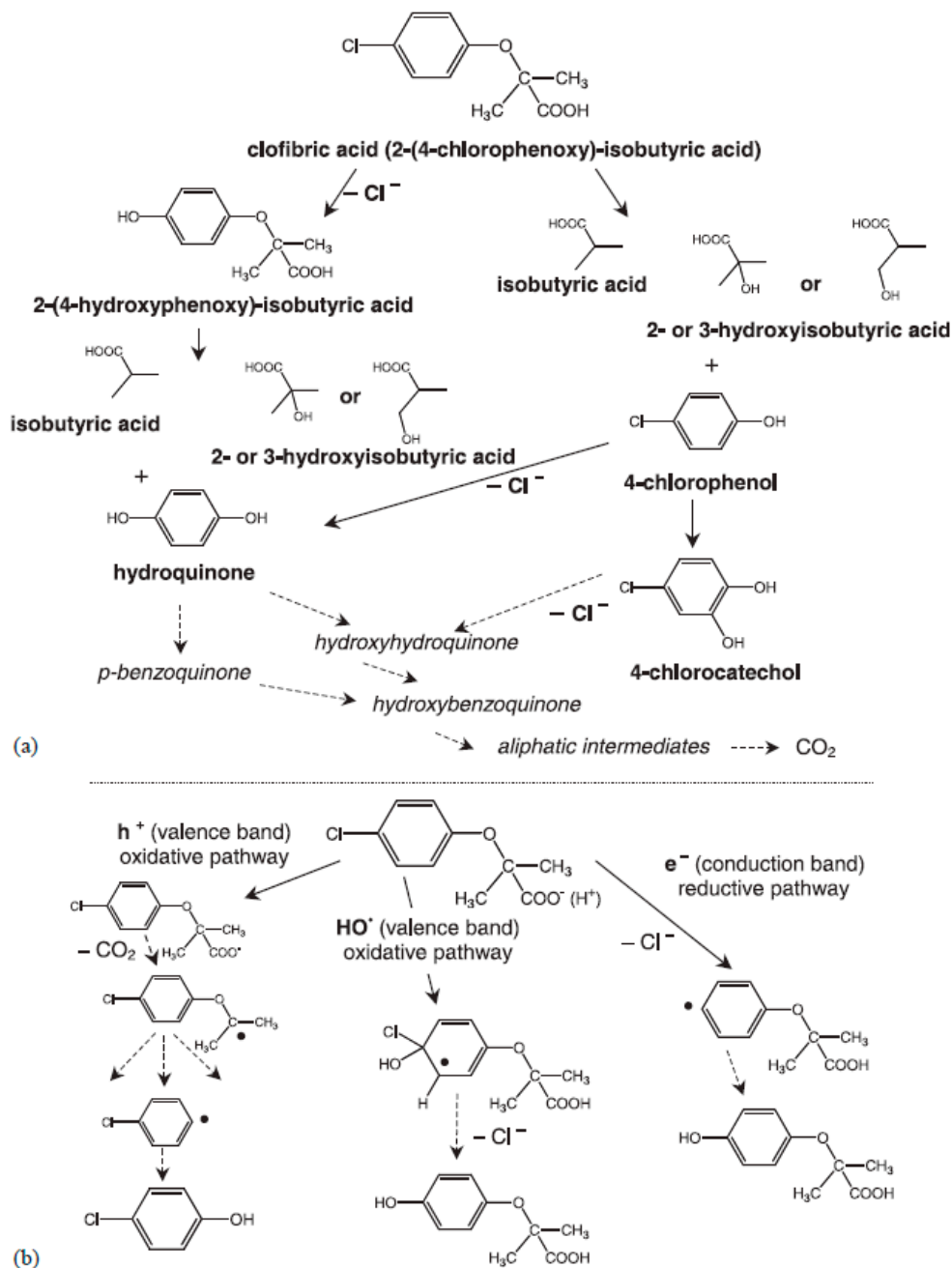

Figure 6. (a): Suggested simplified degradation scheme of the photocatalytic degradation of clofibric acid (Bold: identified intermediates) and (b) example for possible oxidative and reductive reaction pathways of clofibric acid. Reproduced with permission from [44], Copyright Elsevier Ltd., 2003.

On the spur of the growing interest in the production of solar fuels, there is an increased interest in developing solar photocatalysis also for the removal of pharmaceuticals, and several works report on the use of (natural or simulated) solar radiation for the removal of pharmaceuticals. To this respect, the photocatalytic degradation under sunlight of a common antibiotic (lincomycin) was studied in the

presence of P25 [47]. A hybrid system (consisting of a solar photoreactor coupled with a membrane module, used to confine both photocatalyst and pollutants in the reaction environment) was used as a pilot plant (Figure 7). The antibiotic was successfully oxidized and the hybrid system resulted to be particularly useful for that application.

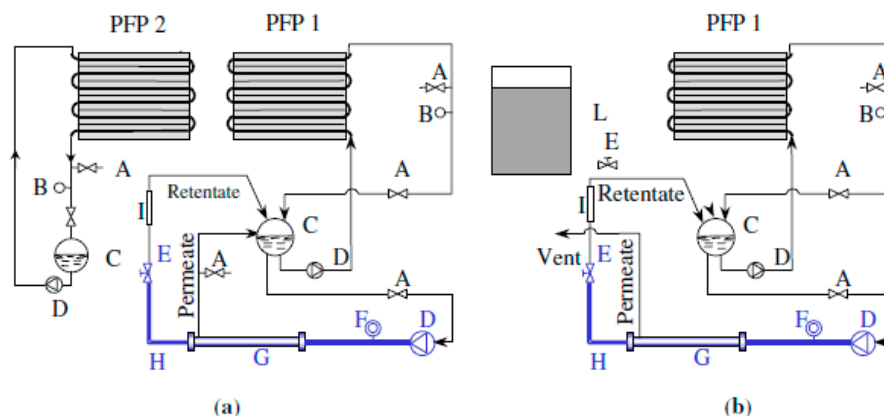

Figure 7. Scheme of the photoreacting batch systems (a) and of the photoreacting continuous system (b): (A) switch valve; (B) thermocouple; (C) non-reacting tank; (D) pump; (E) regulation valve; (F) manometer; (G) membrane vessel; (H) line under pressure; (I) rotameter; (L) feed tank; (PFP) plug flow photoreactor. Reproduced with permission from [47], Copyright Elsevier Ltd., 2005.

The hybrid system allowed the simultaneous separation of the photocatalyst particles and of lincomycin and its degradation products from the permeate flow; indeed, the membrane rejection for those species was quite high. The analyses of the data collected by using the hybrid system, both in total recycle and in continuous regime, indicated that the presence of the membrane allows reducing the amount of both the substrate and intermediates to very low concentration levels.

This shows that the engineering of the photocatalytic system will play a prominent role in the future, in order to allow an effective removal of such pollutants.

A hybrid UV/TiO₂/O₃ approach was adopted for the disposal of fluoxetine [48] and norfluoxetine. The former is the active principle of Prozac[®], the latter is its main metabolite. Both are non-biodegradable and recalcitrant pharmaceutical products, which may be found in surface waters after therapeutic use. Since current wastewater treatments are unable to remove them completely, a hybrid approach was tested, with O₃/H₂O₂ as oxidants and TiO₂ as photocatalyst. In the same papers, other approaches were also tested. In all the experiments, a strong pH dependence of the degradation of fluoxetine was found. When Degussa P25 was adopted as a photocatalyst, the drug adsorption at the surface of TiO₂ NPs played an important role, in that the drug adsorption was enhanced at alkaline pH, whereas mass transfer problems occur at acidic pH (where both the drug and the TiO₂ surface are protonated). A similar result was observed by some of us when the adsorption of negatively charged species on mesoporous TiO₂ were studied [49,50].

From an economic point of view, however, many papers concluded that in the case of drugs, homogeneous photocatalysis has a lower environmental impact as compared to heterogeneous processes.

To this respect, the degradation of α -methylphenylglycine, a common precursor of pharmaceuticals, often chosen as an aromatic amino acid model molecule because of its high water solubility and its non-biodegradable character, has been studied by means of solar photo-Fenton and TiO₂ photocatalytic degradation [51,52].

Solar photo-Fenton (combined with biological systems) is also adopted to treat wastewaters that contain pharmaceuticals. In the paper, solar photo-Fenton was more effective in the degradation, due to a higher degradation rate. A photo-Fenton reaction at relatively low Fe concentration (20 mg L⁻¹) was able to degrade the parent compound completely and to convert the intermediates into biodegradable

compounds in about one hour, without the need for removing Fe from water, as its concentration was compatible with biologically-activated sludge treatment. H_2O_2 consumption is the main drawback of photo-Fenton treatments, both because of its cost and because of the technical issues stemming from the need to eliminate it before the water can be discharged to the biological treatment. However, it has been demonstrated that by properly dosing H_2O_2 , its consumption can be optimized in such a way as to obviate the need for elimination after treatment.

Although photocatalysis can exploit natural solar light for contaminant degradation, its industrial application struggles to be spread due to the dependence of radiation penetration on water depth and the necessity to remove the catalyst at the end of the process. To skip the separation of the nanomaterials from the aqueous medium, which can be an expensive and time consuming step, semiconductors can be immobilized on a support [53]. The support can be either transparent (e.g., glass, silica gel, etc.) or opaque (AC, metals, etc.) material with a strong adherence to the catalyst, a high specific surface area, inertness with respect to the photocatalyst, but with a fair adsorption affinity towards the contaminants [54]. For example, Murgolo et al. show a good efficiency of nanometric TiO_2 supported on single walled carbon nanotubes during the degradation of a mixture of 22 PPCPs either in pure water or in secondary wastewater effluent [55]. Very recently, Karaolia et al. have synthesized graphene-based TiO_2 composite photocatalysts to remove antibiotics and antibiotic-resistant bacteria, such as sulfamethoxazole, erythromycin and clarithromycin, in urban wastewater. Their nanocomposite has shown to be efficient in the photocatalytic degradation of erythromycin (ca. 84%) and clarithromycin (ca. 86%), while the degradation of sulfamethoxazole (ca. 87%) was found to be marginally slower compared to P25 [56].

4.2. Reaction with Nanoscale Zero Valent Iron

In the last two decades, nanoscale zerovalent iron (NZVI) particles have been considered a promising nanomaterial to remove a wide range of contaminants including heavy metals, pesticides and chlorinated solvents from both groundwater and wastewater [57–59].

Usually, NZVI particles are formed by a metallic iron core covered by an iron oxide/hydroxide shell. They are generally suspended in a colloidal dispersion and stabilized by a biopolymer [60,61] or a surfactant and, thanks to the highly specific surface area, can degrade contaminants faster than (commercial) millimetric Fe^0 . Several degradation pathways can occur at the surface of the NZVI, which generally lead to the reduction of the contaminant and the consumption and oxidation of the metallic core (Figure 8).

Very recently, NZVI and commercial iron powder were applied during sludge anaerobic digestion for the removal of 19 different types of PPCPs. They showed good efficiency in the presence of chlorinated PPCPs, whereas no significant improvement was reported for the other types of PPCPs [62].

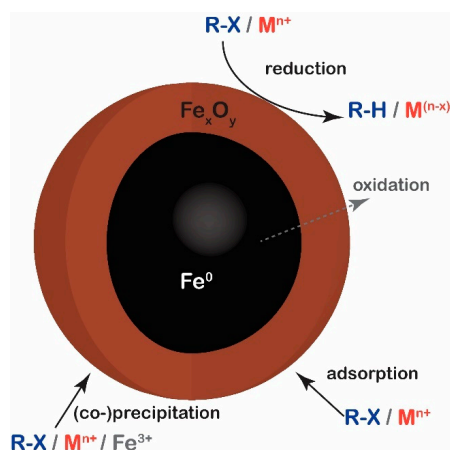

Figure 8. Sketch of a core–shell iron based nanoparticle for water remediation.

Even more recently, Cao et al. have shown that NZVI with a sulfur based shell, (S-NZVI) is able to degrade florfenicol (FF), which is considered a target molecule for ABs. The removal efficiencies were good in groundwater, river water, seawater, and wastewater [63]. In their interesting system, the shell is formed by Fe_xS_y , which has a higher affinity with the hydrophobic part $-Cl$ and $-F$ group on FF compared to the more hydrophilic iron oxides–hydroxides and also facilitates electron transfer due to a lower bandgap than Fe_xO_y .

5. Conclusions and Future Perspectives

Nowadays, it is not possible to think of using fresh water just once, since its scarcity is an enormous environmental problem, both for municipal and agricultural use. Therefore, it is necessary to re-use all kinds of wastewater, including industrial, sanitary and combined sewage wastewater. To make this possible, however, it is necessary to make them completely free from contaminants and environmentally compatible, as well.

Therefore, the legislation of each country should be updated to new, acceptable PPCP threshold values. WWPTS should be upgraded to detect and remove the new PPCs from aquatic systems. In this scenario, (photo)catalysts or nanoparticles coupled with a support or showing magnetic properties could be easily removed from the water after the treatment and easier regenerated than normally-dispersed colloidal nanoparticles with a possible higher efficiency than conservative methods. The application of nanostructured catalysts can be an attractive method since their properties and selectivity can be tuned according to the contaminants present in the wastewater stream (Table 3). Unfortunately, their industrial application is still hindered by their costs and possible toxicological issues. These drawbacks will be easily overcome with future toxicological studies and new synthesis methods. Conservative methods based on nanostructured materials, such as activate carbons, RO and NF are currently cheaper, but their selectivity in contaminant removal is their principal shortcoming. For example, the RO method, along with removing harmful compounds, also removes vitamins and minerals from the water that are essential for healthy drinking water.

Table 3. Summary of the nanostructured catalysts, particles and contaminants. The pH reported refers to the optimum or initial conditions.

Catalyst	SSA ($m^2 \cdot g^{-1}$)	Contaminant	Conditions at Room Temperature	Reference
Degussa P25 (commercial)	-	prozac	75 W High pressure Hg lamp (max 360 nm) + O_3 at pH 11	[47]
Degussa P25 (commercial)	-	α -methylphenylglycine	UV at pH 6	[51]
TiO ₂ (commercial)	-	amoxicillin, ampicillin and cloxacillin	UV (365 nm) at pH 11 and + H ₂ O ₂ at pH 5	[42]
Degussa P25 + NF membrane (both commercial)	50	lyncomycin	UV light at pH 6.3	[46]
TiO ₂ and Aeroxide P25 (commercial)	45–55/35–65	chlorhexidine	UV at pH 10.5	[44]
P25 and Hombikat UV100 (both commercial)	Table 2	carbamazepine, clofibric acid, iomeprol, iopromide	Solar Simulator at pH 6.5	[43]

Table 3. Cont.

Catalyst	SSA (m ² ·g ⁻¹)	Contaminant	Conditions at Room Temperature	Reference
TiO ₂ , P25 and ZnO (all commercial)	-	sulfamethazine	9 W lamp Osram Dulux S (320–400 nm, max 365 nm) at pH 4.8	[38]
TiO ₂ , P25 and ZnO (all commercial)	-	chloramphenicol	9 W lamp Osram Dulux S (320–400 nm, max 365 nm) at pH 5.1 + H ₂ O ₂	[39]
Zr-TiO ₂	100	ibuprofen	4UV-vis solarium lamp	[45]
TiO ₂ on SWCNT (commercial)	-	22 different PPCPs	UV and solar simulated light	[54]
graphene based TiO ₂	45–48	sulfamethoxazole, erythromycin and clarithromycin	1 kW Xenon lamp at pH 5.2–6.2	[55]
ZnO (commercial)	-	amoxicillin, ampicillin and cloxacillin	6 W UV lamp (max 365 nm) at pH 11	[40]
ZnS	-	β-lactam	500 W halogen lamp (visible lamp) at pH 4.5	[41]
NZVI	23.3	19 different PPCPs	In dark, at pH 7	[61]
S-NZVI	62.5	florfenicol	In dark, at pH 7	[62]

From another point of view, methods based on green chemistry or environmentally sustainable chemistry should be implemented in order to reduce the spread of hazardous materials either by the pharmaceutical industry to produce pharmaceutical compounds that are environmentally friendly or by chemistry industry to develop new nanomaterials to remove contaminants.

We are aware that some nanomaterials, (e.g., TiO₂ nanoparticles), used in this type of method, could be *per se* considered as new emerging contaminants: to avoid this, they must be applied with caution, so that they can become a useful tool for the efficient removal of contaminants. To do this, however, there is room for a lot of scientific studies assessing the actual impact of such nanomaterials in order to evaluate the advantages and disadvantages of their use in environmental remediation processes, as well as there is still a lack of regulation that the different countries will soon have to face.

Acknowledgments: This work was supported by Fondazione Cariplo (Italy) through the grant 2015–0186 “DeN—Innovative technologies for the abatement of N-containing pollutants in water”.

Author Contributions: The manuscript was written with the contribution of all the authors.

Conflicts of Interest: The authors declare no conflict of interest.

References

- Luo, Y.; Guo, W.; Ngo, H.H.; Nghiem, L.D.; Hai, F.I.; Zhang, J.; Liang, S.; Wang, X.C. A review on the occurrence of micropollutants in the aquatic environment and their fate and removal during wastewater treatment. *Sci. Total Environ.* **2014**, *473–474*, 619–641. [[CrossRef](#)] [[PubMed](#)]
- Hughes, S.R.; Kay, P.; Brown, L.E. Global Synthesis and Critical Evaluation of Pharmaceutical Data Sets Collected from River Systems. *Environ. Sci. Technol.* **2013**, *47*, 661–677. [[CrossRef](#)] [[PubMed](#)]
- Cizmas, L.; Sharma, V.K.; Gray, C.M.; McDonald, T.J. Pharmaceuticals and personal care products in waters: Occurrence, toxicity, and risk. *Environ. Chem. Lett.* **2015**, *13*, 381–394. [[CrossRef](#)] [[PubMed](#)]
- Kurwadkar, S.; Zhang, X.; Ramirez, D.; Mitchell, F.L. *Emerging Micro-Pollutants in the Environment: Occurrence, Fate, and Distribution*; American Chemical Society: Washington, DC, USA, 2015.

5. Fairbairn, D.J.; Karpuzcu, M.E.; Arnold, W.A.; Barber, B.L.; Kaufenberg, E.F.; Koskinen, W.C.; Novak, P.J.; Rice, P.J.; Swackhamer, D.L. Sources and transport of contaminants of emerging concern: A two-year study of occurrence and spatiotemporal variation in a mixed land use watershed. *Sci. Total Environ.* **2016**, *551–552*, 605–613. [[CrossRef](#)] [[PubMed](#)]
6. Basile, T.; Petrella, A.; Petrella, M.; Boghetich, G.; Petruzzelli, V.; Colasuonno, S.; Petruzzelli, D. Review of Endocrine-Disrupting-Compound Removal Technologies in Water and Wastewater Treatment Plants: An EU Perspective. *Ind. Eng. Chem. Res.* **2011**, *50*, 8389–8401. [[CrossRef](#)]
7. Mottaleb, M.A.; Meziani, M.J.; Matin, M.A.; Arafat, M.M.; Wahab, M.A. Emerging Micro-Pollutants Pharmaceuticals and Personal Care Products (PPCPs) Contamination Concerns in Aquatic Organisms—LC/MS and GC/MS Analysis. In *Emerging Micro-Pollutants in the Environment: Occurrence, Fate, and Distribution*; American Chemical Society: Washington, DC, USA, 2015; pp. 43–74.
8. Goel, S. Antibiotics in the Environment: A Review. In *Emerging Micro-Pollutants in the Environment: Occurrence, Fate, and Distribution*; American Chemical Society: Washington, DC, USA, 2015; pp. 19–42.
9. Tarr, H.L.A.; Boyd, J.W.; Bissett, H.M. Antibiotics in Food Processing, Experimental Preservation of Fish and Beef with Antibiotics. *J. Agric. Food Chem.* **1954**, *2*, 372–375. [[CrossRef](#)]
10. Gilbert, N. Rules tighten on use of antibiotics on farms. *Nature* **2012**, *481*, 125. [[CrossRef](#)] [[PubMed](#)]
11. Henriksson, P.J.G.; Troell, M.; Rico, A. Antimicrobial use in aquaculture: Some complementing facts. *Proc. Natl. Acad. Sci. USA* **2015**, *112*, E3317. [[CrossRef](#)] [[PubMed](#)]
12. Venter, H.; Henningsen, M.L.; Begg, S.L. Antimicrobial resistance in healthcare, agriculture and the environment: The biochemistry behind the headlines. *Essays Biochem.* **2017**, *61*, 1–10. [[CrossRef](#)] [[PubMed](#)]
13. Van Boeckel, T.P.; Brower, C.; Gilbert, M.; Grenfell, B.T.; Levin, S.A.; Robinson, T.P.; Teillant, A.; Laxminarayan, R. Global trends in antimicrobial use in food animals. *Proc. Natl. Acad. Sci. USA* **2015**, *112*, 5649–5654. [[CrossRef](#)] [[PubMed](#)]
14. Heberer, T.; Mechlinski, A.; Fanck, B.; Knappe, A.; Massmann, G.; Pekdeger, A.; Fritz, B. Field Studies on the Fate and Transport of Pharmaceutical Residues in Bank Filtration. *Ground Water Monit. Remediat.* **2004**, *24*, 70–77. [[CrossRef](#)]
15. Ding, S.; Chu, W.; Bond, T.; Wang, Q.; Gao, N.; Xu, B.; Du, E. Formation and estimated toxicity of trihalomethanes, haloacetanitriles, and haloacetamides from the chlor(am)ination of acetaminophen. *J. Hazard. Mater.* **2018**, *341*, 112–119. [[CrossRef](#)] [[PubMed](#)]
16. Ali, A.M.; Rønning, H.T.; Al Arif, W.M.; Kallenborn, R.; Kallenborn, R. Occurrence of pharmaceuticals and personal care products in effluent-dominated Saudi Arabian coastal waters of the Red Sea. *Chemosphere* **2017**, *175*, 505–513. [[CrossRef](#)] [[PubMed](#)]
17. Calamari, D.; Zuccato, E.; Castiglioni, S.; Bagnati, R.; Fanelli, R. Strategic survey of therapeutic drugs in the rivers Po and lambro in Northern Italy. *Environ. Sci. Technol.* **2003**, *37*, 1241–1248. [[CrossRef](#)]
18. Archer, E.; Petrie, B.; Kasprzyk-Hordern, B.; Wolfaardt, G.M. The fate of pharmaceuticals and personal care products (PPCPs), endocrine disrupting contaminants (EDCs), metabolites and illicit drugs in a WWTW and environmental waters. *Chemosphere* **2017**, *174*, 437–446. [[CrossRef](#)] [[PubMed](#)]
19. Ebele, A.J.; Abou-Elwafa Abdallah, M.; Harrad, S. Pharmaceuticals and personal care products (PPCPs) in the freshwater aquatic environment. *Emerg. Contam.* **2017**, *3*, 1–16. [[CrossRef](#)]
20. Magureanu, M.; Mandache, N.B.; Parvulescu, V.I. Degradation of pharmaceutical compounds in water by non-thermal plasma treatment. *Water Res.* **2015**, *81*, 124–136. [[CrossRef](#)] [[PubMed](#)]
21. Klaminder, J.; Jonsson, M.; Fick, J.; Sundelin, A.; Brodin, T. The conceptual imperfection of aquatic risk assessment tests: Highlighting the need for tests designed to detect therapeutic effects of pharmaceutical contaminants. *Environ. Res. Lett.* **2014**, *9*. [[CrossRef](#)]
22. Fritsch, E.B.; Connon, R.E.; Werner, I.; Davies, R.E.; Beggel, S.; Feng, W.; Pessah, I.N. Triclosan impairs swimming behavior and alters expression of excitation-contraction coupling proteins in fathead minnow (*Pimephales promelas*). *Environ. Sci. Technol.* **2013**, *47*, 2008–2017. [[CrossRef](#)] [[PubMed](#)]
23. Pinto, P.I.S.; Guerreiro, E.M.; Power, D.M. Triclosan interferes with the thyroid axis in the zebrafish (*Danio rerio*). *Toxicol. Res.* **2013**, *2*, 60–69. [[CrossRef](#)]
24. Yangali-Quintanilla, V.; Maeng, S.K.; Fujioka, T.; Kennedy, M.; Li, Z.; Amy, G. Nanofiltration vs. reverse osmosis for the removal of emerging organic contaminants in water reuse. *Desalination Water Treat.* **2011**, *34*, 50–56. [[CrossRef](#)]

25. Bellona, C.; Drewes, J.E.; Xu, P.; Amy, G. Factors affecting the rejection of organic solutes during NF/RO treatment—A literature review. *Water Res.* **2004**, *38*, 2795–2809. [[CrossRef](#)] [[PubMed](#)]
26. Nghiem, L.D.; Schäfer, A.I.; Elimelech, M. Removal of Natural Hormones by Nanofiltration Membranes: Measurement, Modeling and Mechanisms. *Environ. Sci. Technol.* **2004**, *38*, 1888–1896. [[CrossRef](#)] [[PubMed](#)]
27. Schäfer, A.I.; Nghiem, L.D.; Waite, T.D. Removal of the natural hormone estrone from aqueous solutions using nanofiltration and reverse osmosis. *Environ. Sci. Technol.* **2003**, *37*, 182–188. [[CrossRef](#)] [[PubMed](#)]
28. Nghiem, L.D.; Manis, A.; Soldenhoff, K.; Schäfer, A.I. Estrogenic hormone removal from wastewater using NF/RO membranes. *J. Membr. Sci.* **2004**, *242*, 37–45. [[CrossRef](#)]
29. Huang, C.H.; Sedlak, D.L. Analysis of estrogenic hormones in municipal wastewater effluent and surface water using enzyme-linked immunosorbent assay and gas chromatography/tandem mass spectrometry. *Environ. Toxicol. Chem.* **2001**, *20*, 133–139. [[CrossRef](#)] [[PubMed](#)]
30. Kimura, K.; Toshima, S.; Amy, G.; Watanabe, Y. Rejection of neutral endocrine disrupting compounds (EDCs) and pharmaceutical active compounds (PhACs) by RO membranes. *J. Membr. Sci.* **2004**, *245*, 71–78. [[CrossRef](#)]
31. Pelekani, C.; Snoeyink, V. Competitive adsorption in natural water: Role of activated carbon pore size. *Water Res.* **1999**, *33*, 1209–1219. [[CrossRef](#)]
32. Crittenden, J.C.; Sanonraj, S.; Bulloch, J.L.; Hand, D.W.; Rogers, T.N.; Speth, T.F.; Ulmer, M. Correlation of aqueous-phase adsorption isotherms. *Environ. Sci. Technol.* **1999**, *33*, 2926–2933. [[CrossRef](#)]
33. Eisenman, G. The Molecular Basis of Ionic Selectivity in Macroscopic Systems. In *Mass Transfer and Kinetics of Ion Exchange*; Liberti, L., Helfferich, F.G., Eds.; Springer: Dordrecht, The Netherlands, 1983; pp. 121–155, ISBN 978-94-009-6899-8.
34. Newcombe, G.; Drikas, M.; Hayer, R. Influence of characterised natural organic material on activated carbon adsorption: II. Effect on pore volume distribution and adsorption of 2-methylisoborneol. *Water Res.* **1997**, *31*, 1065–1073. [[CrossRef](#)]
35. Freyria, F.S.; Armandi, M.; Compagnoni, M.; Ramis, G.; Rossetti, I.; Bonelli, B. Catalytic and Photocatalytic Processes for the Abatement of N-Containing Pollutants from Wastewater. Part 2: Organic Pollutants. *J. Nanosci. Nanotechnol.* **2017**, *17*, 3654–3672. [[CrossRef](#)]
36. Compagnoni, M.; Ramis, G.; Freyria, F.S.; Armandi, M.; Bonelli, B.; Rossetti, I. Photocatalytic Processes for the Abatement of N-Containing Pollutants from Waste Water. Part 1: Inorganic Pollutants. *J. Nanosci. Nanotechnol.* **2017**, *17*, 3632–3653. [[CrossRef](#)]
37. Bonelli, B.; Esposito, S.; Freyria, F.S. Mesoporous Titania: Synthesis, properties and comparison with non-porous titania. In *Titanium Dioxide*; Janus, M., Ed.; InTech: Rijeka, Croatia, 2017, ISBN 978-953-51-5493-8.
38. Kaniou, S.; Pitarakis, K.; Barlagianni, I.; Poullos, I. Photocatalytic oxidation of sulfamethazine. *Chemosphere* **2005**, *60*, 372–380. [[CrossRef](#)] [[PubMed](#)]
39. Chatzitakis, A.; Berberidou, C.; Paspaltsis, I.; Kyriakou, G.; Sklaviadis, T.; Poullos, I. Photocatalytic degradation and drug activity reduction of Chloramphenicol. *Water Res.* **2008**, *42*, 386–394. [[CrossRef](#)] [[PubMed](#)]
40. Elmolla, E.S.; Chaudhuri, M. Degradation of amoxicillin, ampicillin and cloxacillin antibiotics in aqueous solution by the UV/ZnO photocatalytic process. *J. Hazard. Mater.* **2010**, *173*, 445–449. [[CrossRef](#)] [[PubMed](#)]
41. Pouretedal, H.R.; Hasanali, M.A. Photocatalytic degradation of some b-lactam antibiotics in aqueous suspension of ZnS nanoparticles. *Desalination Water Treat.* **2013**, *51*, 2617–2623. [[CrossRef](#)]
42. Holmberg, J.P.; Ahlberg, E.; Bergenholtz, J.; Hassellöv, M.; Abbas, Z. Surface charge and interfacial potential of titanium dioxide nanoparticles: Experimental and theoretical investigations. *J. Colloid Interface Sci.* **2013**, *407*, 168–176. [[CrossRef](#)] [[PubMed](#)]
43. Elmolla, E.S.; Chaudhuri, M. Photocatalytic degradation of amoxicillin, ampicillin and cloxacillin antibiotics in aqueous solution using UV/TiO₂ and UV/H₂O₂/TiO₂ photocatalysis. *Desalination* **2010**, *252*, 46–52. [[CrossRef](#)]
44. Doll, T.E.; Frimmel, F.H. Kinetic study of photocatalytic degradation of carbamazepine, clofibric acid, iomeprol and iopromide assisted by different TiO₂ materials—Determination of intermediates and reaction pathways. *Water Res.* **2004**, *38*, 955–964. [[CrossRef](#)] [[PubMed](#)]
45. Das, R.; Sarkar, S.; Chakraborty, S.; Choi, H.; Bhattacharjee, C. Remediation of antiseptic components in wastewater by photocatalysis using TiO₂ nanoparticles. *Ind. Eng. Chem. Res.* **2014**, *53*, 3012–3020. [[CrossRef](#)]

46. Choina, J.; Fischer, C.; Flechsig, G.U.; Kosslick, H.; Tuan, V.A.; Tuyen, N.D.; Tuyen, N.A.; Schulz, A. Photocatalytic properties of Zr-doped titania in the degradation of the pharmaceutical ibuprofen. *J. Photochem. Photobiol. A Chem.* **2014**, *274*, 108–116. [[CrossRef](#)]
47. Augugliaro, V.; García-López, E.; Loddo, V.; Malato-Rodríguez, S.; Maldonado, I.; Marci, G.; Molinari, R.; Palmisano, L. Degradation of lincomycin in aqueous medium: Coupling of solar photocatalysis and membrane separation. *Sol. Energy* **2005**, *79*, 402–408. [[CrossRef](#)]
48. Méndez-Arriaga, F.; Otsu, T.; Oyama, T.; Gimenez, J.; Esplugas, S.; Hidaka, H.; Serpone, N. Photooxidation of the antidepressant drug Fluoxetine (Prozac[®]) in aqueous media by hybrid catalytic/ozonation processes. *Water Res.* **2011**, *45*, 2782–2794. [[CrossRef](#)] [[PubMed](#)]
49. Piumetti, M.; Freyria, F.S.; Armandi, M.; Geobaldo, F.; Garrone, E.; Bonelli, B. Fe- and V-doped mesoporous titania prepared by direct synthesis: Characterization and role in the oxidation of AO7 by H₂O₂ in the dark. *Catal. Today* **2014**, *227*, 71–79. [[CrossRef](#)]
50. Freyria, F.S.; Compagnoni, M.; Ditaranto, N.; Rossetti, I.; Piumetti, M.; Ramis, G.; Bonelli, B. Pure and Fe-doped mesoporous titania catalyse the oxidation of acid orange 7 by H₂O₂ under different illumination conditions: Fe doping improves photocatalytic activity under simulated solar light. *Catalysts* **2017**, *7*. [[CrossRef](#)]
51. Klavarioti, M.; Mantzavinos, D.; Kassinos, D. Removal of residual pharmaceuticals from aqueous systems by advanced oxidation processes. *Environ. Int.* **2009**, *35*, 402–417. [[CrossRef](#)] [[PubMed](#)]
52. Oller, I.; Fernández-Ibáñez, P.; Maldonado, M.I.; Pérez-Estrada, L.; Gernjak, W.; Pulgarín, C.; Passarinho, P.C.; Malato, S. Solar heterogeneous and homogeneous photocatalysis as a pre-treatment option for biotreatment. *Res. Chem. Intermed.* **2007**, *33*, 407–420. [[CrossRef](#)]
53. Homem, V.; Santos, L. Degradation and removal methods of antibiotics from aqueous matrices—A review. *J. Environ. Manag.* **2011**, *92*, 2304–2347. [[CrossRef](#)] [[PubMed](#)]
54. Shan, A.Y.; Ghazi, T.I.M.; Rashid, S.A. Immobilisation of titanium dioxide onto supporting materials in heterogeneous photocatalysis: A review. *Appl. Catal. A Gen.* **2010**, *389*, 1–8. [[CrossRef](#)]
55. Murgolo, S.; Petronella, F.; Ciannarella, R.; Comparelli, R.; Agostiano, A.; Curri, M.L.; Mascolo, G. UV and solar-based photocatalytic degradation of organic pollutants by nano-sized TiO₂ grown on carbon nanotubes. *Catal. Today* **2015**, *240*, 114–124. [[CrossRef](#)]
56. Karaolia, P.; Michael-Kordatou, I.; Hapeshi, E.; Drosou, C.; Bertakis, Y.; Christofilos, D.; Armatas, G.S.; Sygellou, L.; Schwartz, T.; Xekoukoulotakis, N.P.; et al. Removal of antibiotics, antibiotic-resistant bacteria and their associated genes by graphene-based TiO₂ composite photocatalysts under solar radiation in urban wastewaters. *Appl. Catal. B Environ.* **2018**, *224*, 810–824. [[CrossRef](#)]
57. Freyria, F.S.; Bonelli, B.; Sethi, R.; Armandi, M.; Belluso, E.; Garrone, E. Reactions of Acid Orange 7 with Iron Nanoparticles in Aqueous Solutions. *J. Phys. Chem. C* **2011**, *115*, 24143–24152. [[CrossRef](#)]
58. Freyria, F.S.; Esposito, S.; Armandi, M.; Deorsola, F.; Garrone, E.; Bonelli, B. Role of pH in the aqueous phase reactivity of zerovalent iron nanoparticles with acid orange 7, a model molecule of azo dyes. *J. Nanomater.* **2017**, *2017*. [[CrossRef](#)]
59. Tosco, T.; Petrangeli Papini, M.; Cruz Viggi, C.; Sethi, R. Nanoscale zerovalent iron particles for groundwater remediation: A review. *J. Clean. Prod.* **2014**, *77*, 10–21. [[CrossRef](#)]
60. Tiraferri, A.; Chen, K.L.; Sethi, R.; Elimelech, M. Reduced aggregation and sedimentation of zero-valent iron nanoparticles in the presence of guar gum. *J. Colloid Interface Sci.* **2008**. [[CrossRef](#)] [[PubMed](#)]
61. Comba, S.; Sethi, R. Stabilization of highly concentrated suspensions of iron nanoparticles using shear-thinning gels of xanthan gum. *Water Res.* **2009**. [[CrossRef](#)] [[PubMed](#)]
62. Suanon, F.; Sun, Q.; Li, M.; Cai, X.; Zhang, Y.; Yan, Y.; Yu, C.P. Application of nanoscale zero valent iron and iron powder during sludge anaerobic digestion: Impact on methane yield and pharmaceutical and personal care products degradation. *J. Hazard. Mater.* **2017**, *321*, 47–53. [[CrossRef](#)] [[PubMed](#)]
63. Cao, Z.; Liu, X.; Xu, J.; Zhang, J.; Yang, Y.; Zhou, J.; Xu, X.; Lowry, G.V. Removal of Antibiotic Florfenicol by Sulfide-Modified Nanoscale Zero-Valent Iron. *Environ. Sci. Technol.* **2017**, *51*, 11269–11277. [[CrossRef](#)] [[PubMed](#)]

