

DC-AC Conversion Strategy optimized for Battery or Fuel-Cell-Supplied AC Motor Drives

*Original*

DC-AC Conversion Strategy optimized for Battery or Fuel-Cell-Supplied AC Motor Drives / Fratta, Antonino; Guglielmi, Paolo; Pellegrino, GIAN - MARIO LUIGI; Villata, Franco. - 1:(2000), pp. 230-236. (Intervento presentato al convegno IEEE International Symposium on Industrial Electronics -ISIE'00 tenutosi a Cholula, Puebla, Mexico nel December 4-8, 2000) [10.1109/ISIE.2000.930518].

*Availability:*

This version is available at: 11583/1411877 since:

*Publisher:*

IEEE

*Published*

DOI:10.1109/ISIE.2000.930518

*Terms of use:*

This article is made available under terms and conditions as specified in the corresponding bibliographic description in the repository

*Publisher copyright*

(Article begins on next page)

# DC-AC Conversion Strategy optimized for Battery or Fuel-Cell-Supplied AC Motor Drives

A. Fratta (member), P. Guglielmi, G.M. Pellegrino and F. Villata (member)

Dept. of Electrical Engineering, Politecnico di Torino, C.so Duca degli Abruzzi, 24, 10129 Torino ITALY

**Abstract** - . A novel DC-AC conversion strategy is presented, which is proposing outstanding performances in DC-supplied AC motor drives. Theoretical power system design analyses and wide experimental verifications suggested the adoption of regulated H-Bridge boost DC-DC converter stage improving overall cost and efficiency with respect to direct PWM VSI connection to variable voltage battery supply. In this work, the modulation and control strategies are investigated, suitable for the best exploitation of the power system capabilities. Through a controlled coordination between H-Bridge and VSI modulation patterns and control tasks, minimum PWM ripple contents and linear voltage transfer up to six-step operation are the targets. The resulting strategy, called Cross-over Voltage Modulation, is reported for the first time together with the requested 3- $\Phi$  PWM enhancement called Balanced Envelopes Modulation. CVM strategy is realized and experimental tests are reported showing very satisfactory results, achieving new automotive AC motor drive quality.

## I. Introduction

The DC/AC conversion structure depicted in Fig.1b is the result of accurate power system analysis, PSpice simulations and prototypes experimental verifications, providing results as successful as expected [1-4].

Whenever the DC-source voltage may span around the range  $1 \div 2$ , as in the case of battery or fuel cell supplies [4, 5-7, 9-12], the proposed power system takes to a list of benefits, with reference to the simplest 3 $\Phi$ -VSI connection to the DC-source (Fig.1a):

- power semiconductors size and overall cost reduction, with related conduction and switching loss improvement;
- capability of large reduction of PWM ripple content

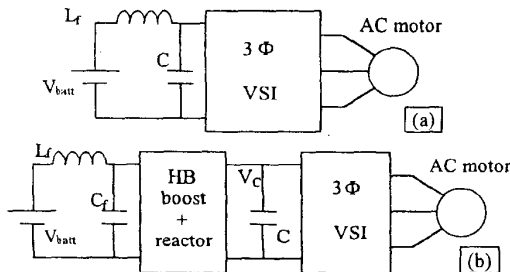

Figure 1: Converter's configuration: (a) Conventional; (b) Adopted

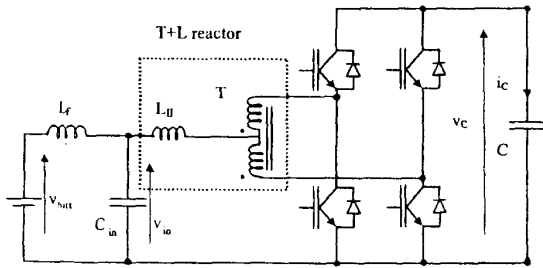

Figure 2: Adopted HBridge Boost Converter

on the AC motor voltages and related additive losses;

- reduction of filter capacitor size requested for low-ripple current supply from the sensitive DC-source.

The main drawback appears related to the need of the coupling power inductor. However, the peculiar H-Bridge structure in Fig.2, adopting a "T+L" reactor (inductive transformer), has proven compact and efficient, with the aid of suitable modulation technique (half modulation period displacement) and high performance current control loops. This allows also for large reduction on input-output current ripple and for increased DC-link voltage control loop bandwidth, strongly reducing DC capacitance size down to PCB soldered film capacitors.

Control complexity might be considered a drawback, nowadays avoided by available integration technologies.

In any case, the possible AC drive system performances are here investigated, in the power system shown in Fig.1b and adopting the DC-DC converter scheme in Fig.2.

Few basic targets are implied: PWM ripple content and related losses minimization by regulated DC-link voltage; linearity between reference and realized fundamental AC voltage from zero up to Six-Step mode, at the maximum allowable voltage for the chosen IGBTs (400V).

## II. Balanced Envelopes Modulation (BEM)

### A. Modulation target and concept.

The basic target of the BEM technique is to obtain the maximum possible linear PWM range in 3 $\Phi$ -VSI by means of a real-time algorithm. This is achieved by real-time addition of a particular common-mode (null-sequence) quantity to the 3 $\Phi$ -references (symmetrical components of the reference vector) to balance their positive and negative envelopes, implicitly maximizes the linear PWM range, that is the 3 $\Phi$ -VSI voltage exploitation.

### B. Analysis of BEM technique.

With reference to Fig.3, the symmetrical components of the reference voltage vector are defined by (1):

$$\vec{V}_N^* = \vec{V} \begin{bmatrix} \cos(\vartheta) & \cos(\vartheta - \frac{2}{3}\pi) & \cos(\vartheta - \frac{4}{3}\pi) \end{bmatrix}^T \quad (1)$$

The 3 $\Phi$ -components envelope " $E_{pos}$ " =  $\max(V_{iN})$  and the negative one " $E_{neg}$ " =  $\min(V_{iN})$  have main impact in BEM concept. Note the third component of (1), not generating neither  $E_{pos}$  nor  $E_{neg}$ , is called " $E_n$ " representing the

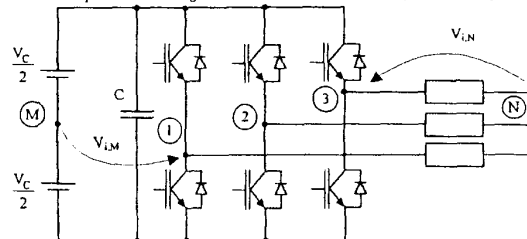

Figure 3: Inverter voltages definition.

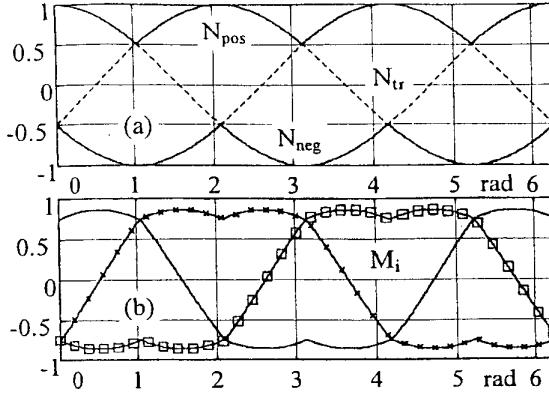

Figure 4: Modulation indexes vs phase angle in BEM technique.

component in “transition” from one envelope to the other, having also a triangular-like shape (see Fig.4a).

Two modulation indexes are defined, namely “ $N$ ” (2) according to phase-to-neutral voltage components:

$$\vec{N} = \vec{V}_N^* \frac{1}{V_C/2} \quad (2)$$

and “ $M$ ” (3) for phase-to mid-point VSI voltages:

$$\vec{M} = \vec{N} + [I] \cdot M_{NM} \quad (3)$$

whose components are actually compared to the PWM triangular carrier having unity envelopes ( $\pm 1 \equiv$  triangular carrier peak); “ $M_{NM}$ ” represents the common-mode quantity added to reference symmetrical components  $N_i$ .

The related voltages to mid-point can be expressed as:

$$V_{i,M} \equiv \frac{V_C}{2} M_i; \text{ being always } |M_i| \leq 1; \quad (4)$$

In the BEM technique  $M_{NM}$  is set and defined in order to balance the envelopes of the vector components  $M_i$  (and equivalently the requested voltages to mid-point  $V_{i,M}$ ). The related common-mode voltage “ $V_{NM}^*$ ” results as follows:

$$V_{NM}^* = - (E_{pos} + E_{neg}) / 2 = E_{tr} / 2 \quad (5)$$

and the related common-mode index value is:

$$M_{NM} = N_{tr} / 2 = - (N_{pos} + N_{neg}) / 2 \quad (6)$$

Figure 4b shows the components  $M_i$  resulting from sinusoidal references  $N_i$  and application of (6) to (3), implicitly defining the transformed indexes  $N_{tr}$ ,  $N_{neg}$ ,  $N_{pos}$ .

The common-mode rejection is a property of three phase loads without neutral connection, as known, so that the load voltage components  $V_{iN}$  reappear equal to reference ones provided that  $M_i^*$  modules are lower than unity:

$$V_{iN} = V_C / 2 (M_i - M_{NM}) \quad (7)$$

This technique allows for easy linearity extension up to physical real-time limits. In steady-state sine operation BEM performs as other method does (SVM or added 3<sup>rd</sup> harmonics), achieving 15% more linear range with respect to holding  $M_{NM}=0$ , as deduced from Fig.4 graphs.

### III. Crossover Voltage Modulation (CVM)

The BEM technique is adopted all over the AC voltage range, from zero up to six-step mode, as the fundamental building block of CVM. The real-time DC-link voltage regulation allows for sinusoidal or high-quality AC outputs by switching only one 3 $\Phi$ VSI-leg per 3 $\Phi$ -sector.

#### A. Basics of single-leg PWM by balanced envelopes.

The BEM technique can be used to reproduce a linear three phase modulation strategy by switching only one 3 $\Phi$ VSI-leg in each sector, thus largely reducing switching losses and PWM ripple content.

The statement for first sector ( $0 \leq \vartheta \leq \pi/6$ ) is reported:

$$\vec{M}^* = [1 \quad f(\vartheta) \quad -1]^T; M_{NM} = f(\vartheta)/3 \quad (8)$$

Two  $M_i$  components set the envelopes to unity and the third component is in “transition” between the envelopes according to the generic function “ $f(\vartheta)$ ”, which implicitly defines the common mode index  $M_{NM}$  shape (8).

The effects of such modulation approach are:

- the vector argument is set by the transition component, that is the function  $f(\vartheta)$ ;
- the voltage vector amplitude is set by actual dc-link voltage value and it is affected by argument function.

Since the PWM allows for straightforward realization of every  $f(\vartheta)$  value within unity, the main control task is represented by real-time control the DC-link voltage.

#### 1. Sinusoidal output by Quasi-Trapezoidal Modulation.

The real-time DC-link voltage regulation in the electrical period can hold single-leg PWM benefits with linear voltages transfer function.

Equating (1) and (7) with the constraint (8) yields:

$$E6 = E_{pos} - E_{neg} \quad (9)$$

$$V_C = E6 = V_{1N}^* - V_{3N}^* = \hat{V} \sqrt{3} \cos(\vartheta - \frac{1}{6}\pi) \quad (10)$$

$$f(\vartheta) = \frac{\frac{3}{2} E_{tr}}{\frac{1}{2} V_C} = \frac{\frac{3}{2} V_{2N}^*}{\frac{1}{2} V_C} = \sqrt{3} \tan(\vartheta - \frac{1}{6}\pi) \quad (11)$$

The same calculation can be done for all sectors showing that first part of eqs. (9-11) are valid by properly defining  $E_{pos}$ ,  $E_{neg}$  and  $E_{tr}$  according to section II.

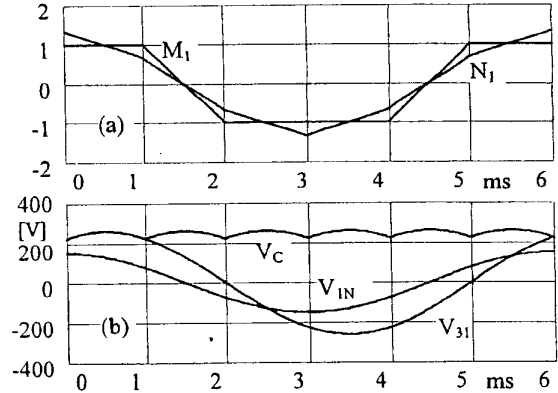

Figure 5: (a) Indexes  $N_i$  and  $M_i$ ; (b)  $V_i$ ,  $V_{3i}$ ,  $V_C$  @166Hz  $\hat{V} = 150$  V

Figure 5 shows coherent waveforms of homologous modulation indexes  $N_i$ ,  $M_i$ , output voltage  $V_i$  together with the DC-link voltage  $V_C$ . The line-to-line voltage  $V_{3i}$  gives evidence to relationship with the DC-link voltage.

Being  $\pm 1$  the modulation limits, each inverter leg is not in PWM mode when the homologous index module is equal or greater than unity.

#### 2. QTM with double-clamped DC-voltage.

The drawback of DC-link voltage profile is the related rms current in the DC-link capacitors (dotted line Fig.6b).

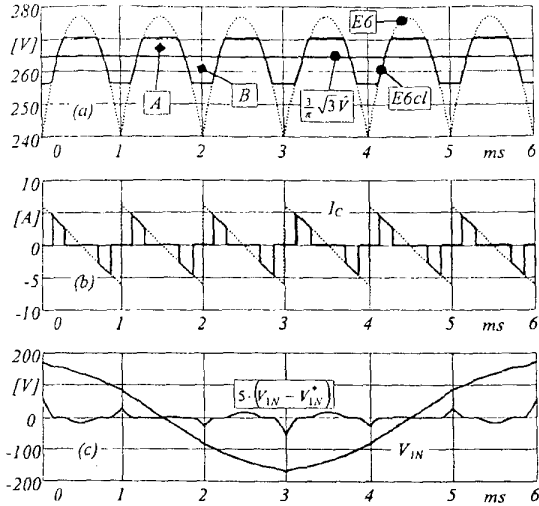

Figure 6: DC-link voltage clamp effect @166Hz  $\hat{V} = 150$  V

Minimum DC-link capacitor value has been suitably realized, together with PWM phase and frequency relationship between DC and AC converter sides in order to contain the produced rms current value. Anyway the DC-link voltage should be limited with increasing AC voltage amplitude and motor electrical frequency.

The adopted control solution, reported in Fig.7, clamps the DC voltage reference  $V_{C,ref}$  (otherwise equal to  $E6$ ) at proper max-min values  $a\sqrt{3}\hat{V}$  and  $b\sqrt{3}\hat{V}$ , respectively, obtaining the current ripple reduction reported in Fig.6.

Signals "a" and "b" span over the ranges.

$$\frac{3}{\pi} \leq a \leq 1; \quad \frac{\sqrt{3}}{2} \leq b \leq \frac{3}{\pi} \quad (12)$$

Their instantaneous values are related to each other in order to hold the mean value of the  $E6cl$  signal equal to that of the input signal  $E6$ . This means that the areas of the two part "A" and "B" in Fig.6a have to be equal in order to maintain the fundamental component of realized AC voltages equal to the reference one. This has been proved numerically obtaining an error of less than 0.2%.

In the overall control scheme in Fig.7, the value of the clamping signal  $a$  is imposed by a pure integral regulation of the dc-link capacitor rms current to less than a maximum reference value; suitable function  $b(a)$  is then realized. The  $I_{C,rms}$  current in the DC-link capacitor bank is derived from the DC-link voltage  $V_C$  signal.

The effects on voltages of this limitation is easily explained when  $a=b=3/\pi$ . In this condition the realized voltages to mid-point are trapezoidal-like as modulation indexes  $M_i$  are. If  $a \neq b$  the shape of the AC voltages is sharing trapezoidal and sinusoidal segments as it can be seen in Fig.6c on phase-to-neutral voltage, where the zoomed transfer error points out the double clamp effect.

This clamping technique holds the first harmonic linearity also when the upper clamp is provided by  $V_{C,ref}$  limitation to maximum DC-voltage  $V_{C,MAX}$ .

### B. CVM operation vs. AC voltage amplitude.

Due to the adopted DC-DC-AC structure and to physical limitations, there are four different operating ranges depending on reference voltage amplitude. Fig.7 block scheme is valid for all of these ones.

#### 1. Conventional 3Φ-PWM mode: constant $V_C \equiv V_{batt}$

The first range represents the usual PWM operation at constant DC voltage, since the DC link voltage  $V_C$  cannot be controlled down to zero due to the DC-DC boost configuration.

If  $V_{batt} \geq \sqrt{3}\hat{V}$ ,  $V_C$  must be equal to battery voltage and the 3Φ-VSI is equivalently connected to the battery by the free-wheeling diodes of the DC-DC converter (motoring).

The variable gain represented by  $V_{div}$  in Fig.7 is coherently fixed to  $V_{batt}/2$  by a saturation block simulating the DC-DC behavior.

As a result, the 3Φ-VSI operates the PWM control of both phase and amplitude of the realized voltage vector (as a common SVM, here substituted by the defined BEM).

The modulation frequency for this range can be set by tradeoff between current ripple and switching losses. In our prototype it is fixed at 5kHz thanks to reduced DC voltage.

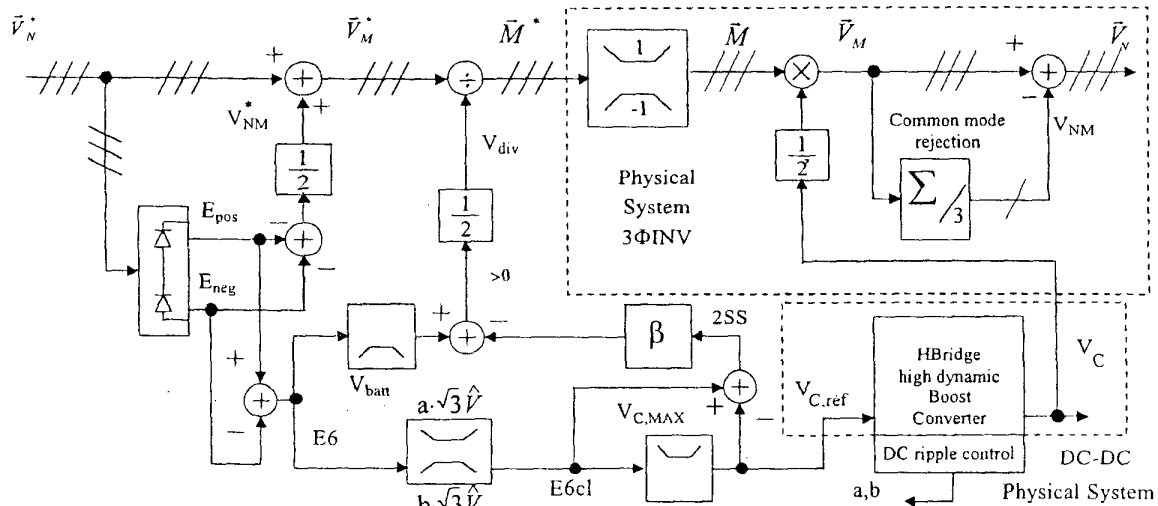

Figure 7: CVM technique block scheme

2. Transition to QTM:  $V_{batt} \leq V_C \leq 2/\sqrt{3} V_{batt}$

Equation (10) shows that the QTM can be adopted with two limitations to be verified at the same time:

$$\min(V_{C,ref}) = \frac{3}{2} \hat{V} \quad \text{and} \quad \max(V_{C,ref}) = \sqrt{3} \hat{V} \quad (13)$$

When battery voltage is within the two limits in (13) the system follows two different modulation strategies (3 $\Phi$ -BEM and single-leg QTM) depending on the continuously variable instantaneous ratio between  $V_{C,ref}$  and  $V_{batt}$ .

Fig.8a shows the angular modulation segments of the modulation index vector locus (bolded line), while Fig.8b shows the related  $V_C$  waveform evidencing the inherent lower clamp function of the boost converter.

The two modulation zones adopt different modulation carriers (5kHz for 3 $\Phi$ -BEM and 20kHz for single-leg QTM) holding low switching losses. A simple Gate Array logic operates the change between the PWM carriers at lowest frequency (5kHz). This carrier changes allows for phase and frequency coordination between DC-DC and DC-AC power stages, thus minimizing DC capacitor ripple and rms current value.

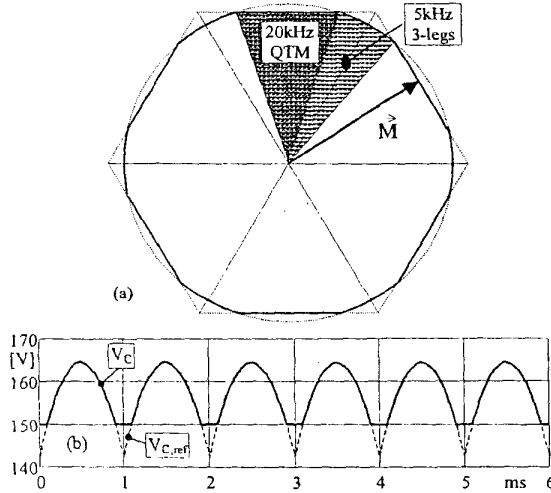

Figure 8: (a) Modulation index locus on the limit hexagon; (b)  $V_C$  in the transition to QTM zone @  $V_{batt}=150V$ ,  $\hat{V} = 95V$

3. QTM:  $2/\sqrt{3} V_{batt} < V_C < V_{C,MAX}$

In this third range the DC-link voltage could be completely controlled and the modulation of the 3 $\Phi$ -VSI can be realized by switching only one leg per sector.

This range can be further divided in three zones depending on clamps action as described in section III.A.2.

- 3.1 Sinusoidal output: no clamps act in this zone; outputs are sinusoidal (instantaneous linearity)
- 3.2 Double-clamped  $V_C$ : current limitation arise and odd harmonics are added to the fundamental output;
- 3.3 Constant  $V_C$ : when the two clamps are equal to each other ( $a = b = 3/\pi$ ) the DC-voltage is set to the mean value of  $E6$  ( $V_C = \sqrt{3} \hat{V} 3/\pi$ ); outputs derive from trapezoidal-like QTM indexes shape.

It can be supposed that these three zones are sequentially performed with the reference vector amplitude, since voltage and frequency are generally proportional to each

other, thus making grow of the  $I_{C,rms}$  component with fundamental amplitude.

4. From QTM to Six-Step mode:  $V_C = V_{C,MAX}$

When  $\vec{V}_N^*$  is generating an  $E6$  signal with a mean value greater than  $V_{C,MAX}$ ,  $V_{C,ref}$  is fixed to  $V_{C,MAX}$  (switches maximum voltage rating protection).

By constant and constrained  $V_C$  value, the first harmonic content of AC voltages can grow a few percent up to six-step operation, however the modulation indexes have to grow up faster than the reference voltage does (pure Six-Step mode obtainable by infinite modulation indexes).

Holding the triangular carrier PWM, the adopted scheme in Fig.7 increases the gain on modulation indexes by reducing the divider  $V_{div}$ , proportionally to the difference between the mean value of  $E6$  and  $V_{C,MAX}$ .  $\beta$  could represent a suitable function, while in the proposed scheme it is simply a proportional gain; the maximum linearity error is less than 1.2% on the realized fundamental component of AC voltages.

In Fig.9 a simulation of quasi-six-step operation is presented; only part of each sector is modulated by a single phase. This allows for monotonous rise to maximum realizable fundamental component, reported by (14):

$$\hat{V}_{MAX,SS} = 2/\pi V_{C,MAX} \approx 255V \quad (14)$$

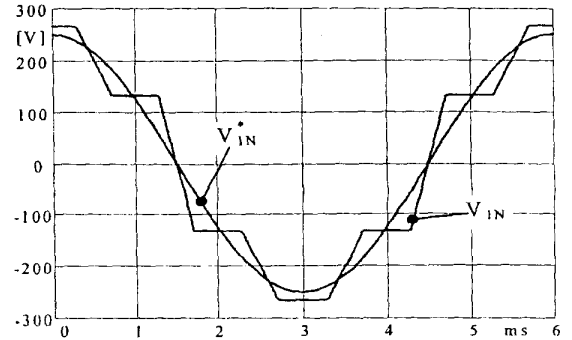

Figure 9: Quasi Six Step mode, @  $V=250V$ ,  $V_C=400V$ ,  $f_{sw}=166Hz$

## 5. Full-range voltage transfer

The graphs in Fig.10 reports the calculated main harmonics (fundamental, 5<sup>th</sup> and 7<sup>th</sup>) all over the different modulation ranges, versus the reference line-to-line voltage amplitude and at  $V_{batt}=150V$ .

PWM, QTM and related transition perform "perfect" transfer without main-harmonics.

The upper  $a$  dc-link clamp action is started at 250V and it is linearly enhanced (zone 3.2) to reach QTM constant- $V_C$  operation at 350V. As shown, the unity transfer function of fundamental component (line-to-line amplitude) is maintained till the maximum realizable amplitude, while harmonics appear in zone 3.2, monotonously increasing with the clamp action.

These harmonics hold the QTM spectrum in zone 3.3, their absolute value varying only with the DC voltage.

In the last range, the harmonics grows up to six-step spectrum content. Note the small fundamental transfer error, related to simple linear reduction of the divider  $V_{div}$  (constant gain  $\beta$ ) with reference amplitude.

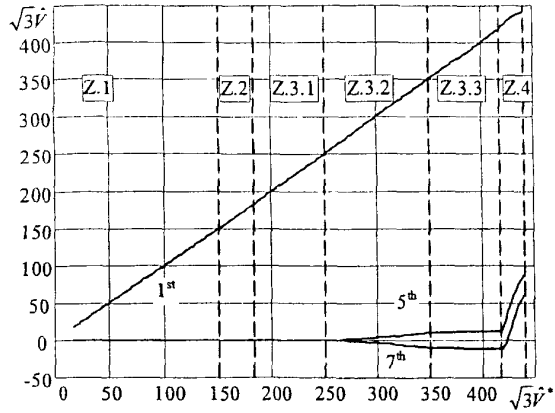

Figure 10 Working zones; fundamental, 5<sup>th</sup> and 7<sup>th</sup> harmonics of line-to-line voltage vs. reference one,  $V_{\text{lim}}=150\text{V}$ ,  $V_{C,\text{MAX}}=400\text{V}$

#### IV. Experimental Results

The power system is composed by two equal 3 $\Phi$  power PCBs, connected each other by the DC-link side and differently disposed to realize the DC-DC (one leg unused) and the DC-AC stages.

Each PCB adopts high-rms-current small film capacitors (Unlytic) and one 3 $\Phi$ -IPM (Mitsubishi PM200CVA060) with dedicated driver opto-insulated buffers, supply and auxiliary protection circuits, as shown in Fig. 11.

The principal characteristics of the power system are:

- 30kW peak power, limited by 150Vx200A DC input;
- Extremely low DC-link capacitance ( $C=42\mu\text{F}$  film);
- Small input capacitance filter (3.3mF electrolytic);
- Modulation frequencies: 10kHz for the DC-DC side; 5-20kHz for the inverter side depending on operating point (see section III.b.2).

Such a low capacitance value has been purposely tested for overall integration and cost, improving the dynamic performance of the DC-DC converter and reducing the  $I_{C,\text{rms}}$  value needed to follow the reference voltage profile. The DC-DC converter is closed-loop controlled by a dedicated non linear strategy already reported [3].

The battery has been simulated by rectifying a variable AC source with large DC capacitor bank (60mF).

A small induction motor at no load is used as open-loop electrical AC load, regulating independently amplitude and frequency to verify all operating voltage ranges.

The experimental results are reported in Figs.12-17 by equal scaling factors: in the upper part the line-to-midpoint voltage  $V_{IM}$  and the modulation index  $M_1$  (bolded); in the lower part the line-to-neutral voltage  $V_{IN}$  and its mean value. This one is realized by oscilloscope digital filter and suffers of critical compromise between sampling and filtering rates.

All operating ranges are reported, showing very good experimental performances, matching numerical results.

Figure 13 reports zoomed sixth of electrical period, pointing out the modulation frequency change from 5 to 20 kHz without modulation error.

What clearly appears on motor voltages is the strong reduction of PWM content, related to minimum DC-voltage in Fig.11 and disposed by QTM technique for increasing AC voltage values. Sinusoidal output is held until Fig.15 zone, while progressively increased harmonic distortion is introduced up to quasi six-step zone in Fig.17.

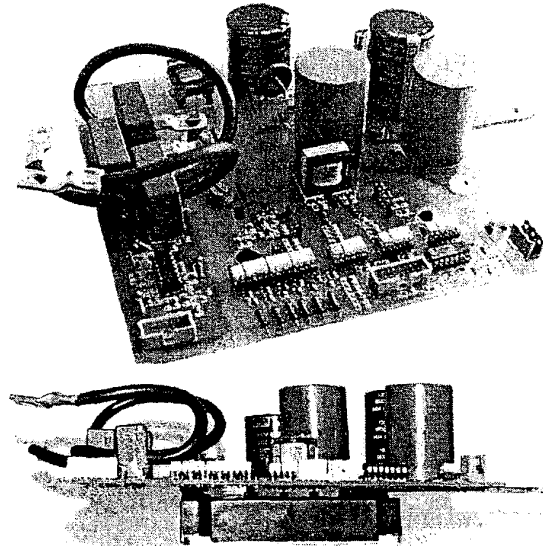

Figure 11 Power PCB arranged for HB DC-DC converter

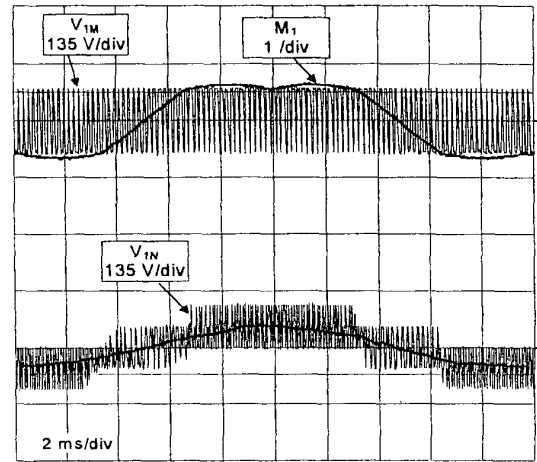

Figure 12 Zone 1:  $\hat{v} = 100/\sqrt{3}$  V; fac=50Hz;  $f_{\text{sw}}=5\text{kHz}$ ;

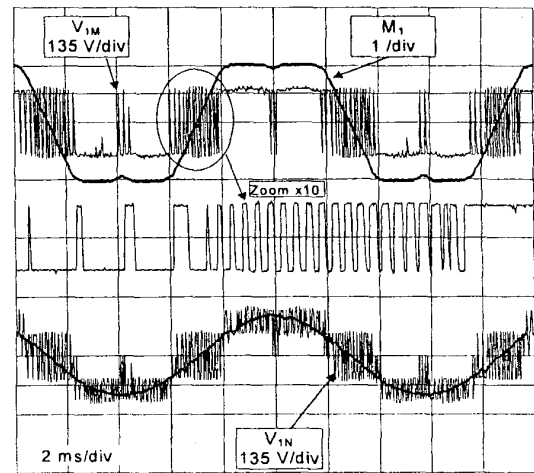

Figure 13 Zone2:  $\hat{v} = 164/\sqrt{3}$  V; fac=82Hz;  $f_{\text{sw}}=5\text{-}20\text{kHz}$ ;

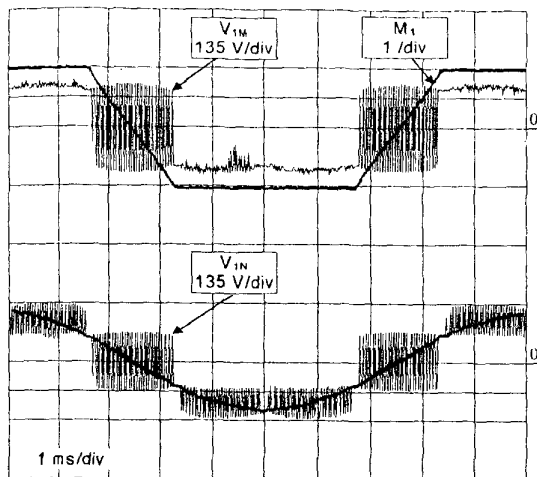

Figure 14 Zone 3.1:  $\hat{v} = 200/\sqrt{3}$  V;  $f_{ac}=100\text{Hz}$ ;  $f_{sw}=20\text{kHz}$ ;

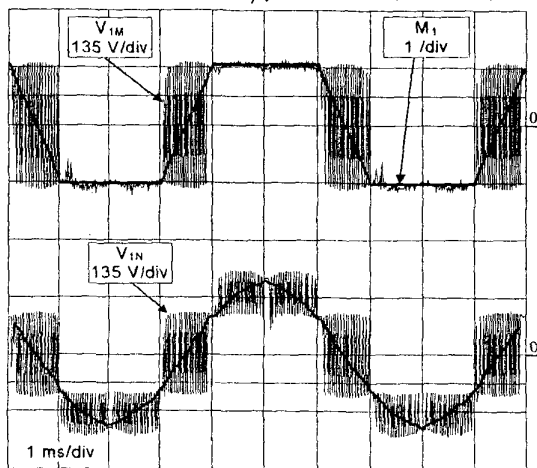

Figure 15 Zone 3.2:  $\hat{v} = 300/\sqrt{3}$  V;  $f_{ac}=166\text{Hz}$ ;  $f_{sw}=20\text{kHz}$ ;  $a=0.97$ .

## V. Conclusions

A novel DC-DC-AC power conversion system has been presented for automotive DC-supplied AC motor drives.

New BEM technique and CVM concept have been investigated in order to fulfill the improvements achievable by the cascaded DC-DC-AC power stages, defining the different voltage ranges and modulation properties.

The experimental results are very satisfactory, showing outstanding AC motor voltage quality, obtained together with improved overall DC-AC conversion efficiency.

Further investigations are planned for the evaluation of the expected reduction on AC motor eddy PWM losses, achieved by the new CVM strategy.

## REFERENCES

- [1] A. Fratta, P. Guglielmi, F. Villata, A. Vagati, "Efficiency and cost-effectiveness of AC drives for electric vehicles improved by a novel boost DC-DC conversion structure", 1998 IEEE Workshop on Power Electronics in Transportation (WPET 98), pp. 11-19.
- [2] A. Fratta, P. Guglielmi, G.M. Pellegrino, F. Villata, "Power loss analysis and measurement of a high efficiency DC-DC converter for EV traction AC drives", 2000 IEEE International Conference on Industrial Technology (ICIT 2000), pp. 347-352.
- [3] A. Fratta, P. Guglielmi, G.M. Pellegrino, F. Villata, "Efficient Modulation Technique and NL Control of H-bridge Boost Converters

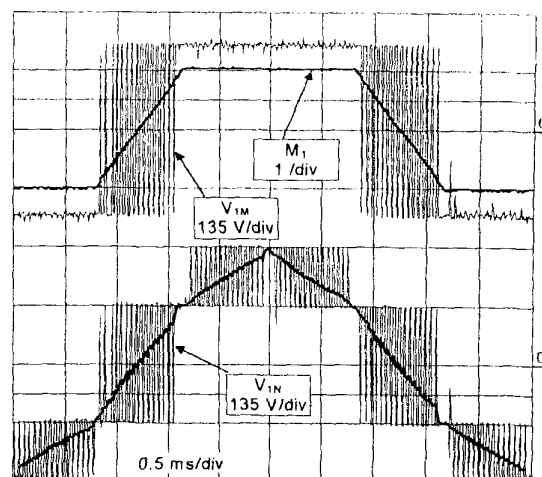

Figure 16 Zone 3.3:  $\hat{v} = 400\pi/(3\sqrt{3})$  V ( $\sim 242\text{V}$ );  $f_{ac}=200\text{Hz}$ ;  $f_{sw}=20\text{kHz}$ ;

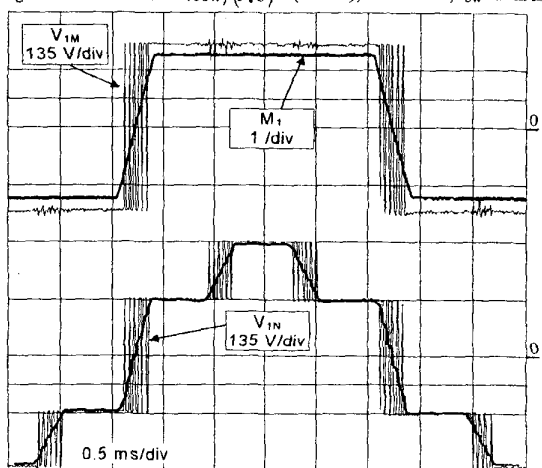

Figure 17 Zone 4  $\hat{v} = 250$  V;  $f_{ac}=200\text{Hz}$ ;  $f_{sw}=20\text{kHz}$ ;

for Battery-Supplied AC Motor Drives", 1999 IEEE International Symposium on Industrial Electronics (ISIE 99), pp. 806-812.

- [4] A. Vagati, A. Fratta, P. Guglielmi, G. Franchi, F. Villata, "Comparison of AC Motor Based Drives for Electric Vehicle Application", 1999 Power Conversion & Intelligent motion (PCIM '99).
- [5] F.R. Kalhammer, P.R. Prokopius, V.P. Roan G.E. Voecks, "Fuel Cells for Future Electric Vehicles", 1999 Battery Conference on Applications and Advances, 1999, pp5-10
- [6] K. Wang, C.Y. Lin, L. Zhu, D. Qu, Lee, F.C. J.S. Lai, "Bi-directional DC to DC converters for fuel cell systems", Power Electronics in Transportation, 1998, 1998, Page(s): 47-51
- [7] X. Xu, V. A. Sankaran, "Power Electronics in Electric Vehicles: Challenges and Opportunities", IAS Annual Meeting Conference Record 1993, Vol. 1, pp. 463-469.
- [8] K. Rajashekara, "History of Electric Vehicles in General Motors", IEEE Transaction on Industry Applications, Vol. 30, No.4, July/August 1994, pp. 897-904.
- [9] "Indagine su tecnologie innovative nel campo dei veicoli elettrici ed ibridi", "Research report on innovative technologies for EV and HEV", Contratto di Ricerca ENEA - Politecnico di Torino, Vol. I-II-III, 1997 ENEA CRE Casaccia, Roma, Italy.
- [10] T.W. Eford, Y.S.S. Ando, A. Kanezaki, "Development of Aluminum Electrolytic Capacitors for EV Inv. Applications", IEEE IAS Annu Meet. Conf. Rec. 97, 1034-1041.
- [11] Jung-Goo Cho, Ju-Won Baek, Geun-Hie Kim, Iouri Kang, "Novel Zero-Voltage-Transition PWM Multiphase Converters" IEEE Trans. on Power Electronics, Vol. 13, No.1, January 1998, pp. 152-159.
- [12] "Nickel-metal hydride: ready to serve", IEEE Spectrum, December 1998, pp.29-34.