

Arc Welding Processes: An Electrical Safety Analysis

Original

Arc Welding Processes: An Electrical Safety Analysis / Freschi, Fabio; Giaccone, Luca; Mitolo, Massimo. - In: IEEE TRANSACTIONS ON INDUSTRY APPLICATIONS. - ISSN 0093-9994. - ELETTRONICO. - 53:2(2017), pp. 819-825. [10.1109/TIA.2016.2626260]

Availability:

This version is available at: 11583/2674200 since: 2017-06-07T14:49:13Z

Publisher:

Institute of Electrical and Electronics Engineers Inc.

Published

DOI:10.1109/TIA.2016.2626260

Terms of use:

This article is made available under terms and conditions as specified in the corresponding bibliographic description in the repository

Publisher copyright

(Article begins on next page)

Electrical Safety in Arc Welding Processes.

Fabio Freschi, SM IEEE
Luca Giaccone, SM IEEE
Politecnico di Torino
Corso Duca degli Abruzzi, 24
10129 Torino (Italy)
{name.surname}@polito.it

Massimo Mitolo, SM IEEE
Engineering Systems Inc. (ESI)
26632 Towne Centre Drive
Foothill Ranch CA, 92618
mitolo@ieee.org

Abstract – Manual metal arc welding can be a hazardous practice if proper precautions are not taken. The welding procedure uses an open electric arc between an electrode and the metals to be joined. Besides the obvious risks of burns and inflammation of the cornea, which are prevented by using proper personal protective equipment, the operator may also be subject to the risk of electric shock from the exposed parts of the welding circuit, both the electrode and the workpiece. In addition, the welding current, by straying from the intended path, can cause localized heating of parts, with the risks of triggering fires and/or explosive atmospheres. Because of the high current required by the arc welding equipment, operators are exposed also to strong electromagnetic fields. This paper seeks to clarify the aforementioned issues, especially in light of the fact that the risk associated with electric shocks may be unknown to welders and their supervisors.

Index Terms – arc welding, electric shock, electrical safety, human exposure, protective conductor

I. INTRODUCTION

The arc welding is a fusion welding, in which the heat for welding is obtained from an electric arc. The manual metal-arc welding uses a covered metal electrode in the shape of a rod or wire from which the current passes to the arc.

The arc welding power source is characterized by a constant current output, so that to ensure that current and heat remain relatively constant, even if the arc length and voltage change. This arrangement facilitates the welding procedure, which requires that the operator use a welding electrode and a return current clamp to be attached to the workpiece (Fig. 1), which are both exposed to the accidental touch of the welder.

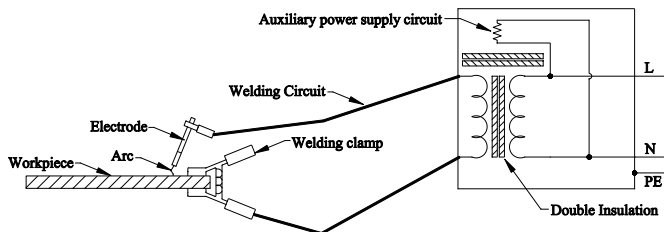

Fig. 1 Manual metal arc welding set up.

The electrode holder connects to the welding cable and conducts the welding current to the electrode from the power source; the welding current flows to the source through the workpiece, and the return current clamp. Arc welding clamps are designed to make a stable electrical connection to the workpiece without the aid of additional tools [1]. Electrode holders must be rated on their current-carrying capacity, and fully insulated [2].

Reference [3] prescribes that the rated rms. value of the no-load voltage of the supply must not exceed 80 V, or the peak of 113 V for direct-current machines; the no-load rms value is reduced to 48 V, if the arc welding takes place in environments with increased risk of electric shock (the peak value for dc machines remains instead the same also in this case). Reference [4] does confirm the value of 80 V rms in ordinary environments for alternating-current machines, and more conservatively prescribes the limit of 100 V for dc arc welding machines.

To minimize the risk of electric shock, welders should wear specifically designed personal protective equipment (PPE) during welding and allied processes¹ (e.g. insulating gloves and shoes, insulating mats) [5] [6]. Standard welding PPE may not be designed to protect against electric shock.

II. RISK OF ELECTRIC SHOCK

The prescribed values of no-load voltages, although below typical nominal system voltages, exceed the limits conventionally assumed as dangerous for direct contact with parts normally live, which are 25 V in ac and 60 V in dc. These limits are based on the concept that the risk of electric shock associated with contact with parts normally live (e.g. the welding electrode) is greater than the risk of contact with parts that could become energized only in fault conditions [7].

The arc welding source may also supply power to other equipment, such as auxiliary circuits, cooling liquid, gas to shield the arc and the welding area, etc., which may be at voltages greater than the allowable no-load voltages. To

¹ Allied processes are for example electric arc cutting and arc spraying.

prevent the welding circuit from being energized at such voltages, [3] recommends a supply transformer equipped with double insulation (i.e. basic insulation plus supplementary insulation), or with a reinforced insulation, in accordance with [8].

The welding circuit must not be internally connected to the enclosure of the welding machine, which may be connected to ground via a protective conductor (PE) [9] (also referred to as *equipment grounding conductor*). By not intentionally grounding either terminal of the machine it is assured that in the case of contact with either the electrode or the clamp, only a modest touch current will circulate; this touch current is due to the parasitic distributed capacitance between the welding circuit connections and the PE (Fig. 2).

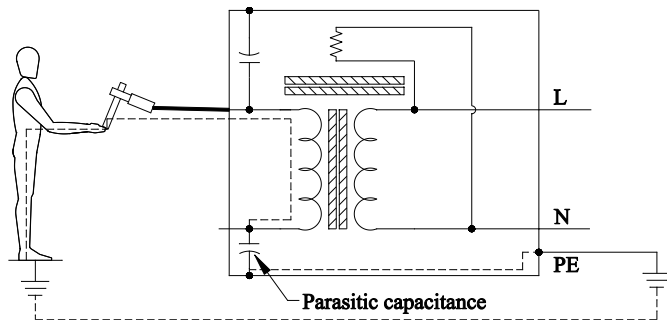

Fig. 2 Touch current between welding circuit connections and PE

Reference [3] requires that this capacitive current must not exceed 14.1 mA peak.

The simultaneous direct contact with the electrode and the clamp exposes the operator to the no-load voltage of the welding machine. This hazardous situation can also occur if either electrode or clamp rest on conductive surfaces that are then simultaneously touched. In general, metallic components bonded to the workpiece increase the risk of electric shock for the operator touching at the same time these parts and the electrode; the operator should be insulated from all such bonded metallic components.

If the workpiece is naturally or intentionally grounded, the exposure to the no-load voltage may occur by merely touching the welding electrode.

Similarly, if the basic insulation of the welding circuit fails, the welder may be exposed to the no-load voltage by touching the workpiece (Fig. 3)

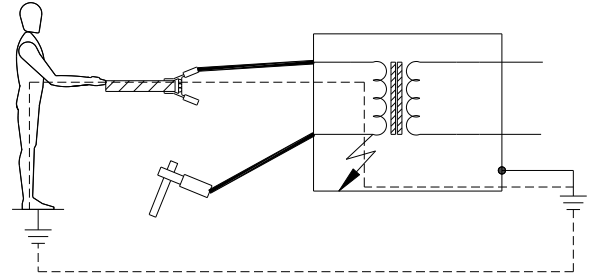

Fig. 3 Failure of the basic insulation of the welding circuit

III. ENVIRONMENT WITH INCREASED RISK OF ELECTRIC SHOCK

Reference [3] prescribes the reduction of the no-load voltage of welding machines to 48 V rms in environments where the probability of electric shock is increased with respect to normal arc welding conditions. Such environments include locations [10]:

1. in which the freedom of movement is restricted so that the welder may be performing the welding in a cramped position (e.g. kneeling) in physical contact with conductive parts;
2. which are fully or partially limited by conductive surrounding parts with which the operator may come into contact with a high probability;
3. in wet and/or damp and/or hot locations, where humidity and/or perspiration significantly reduce the skin resistance of the person, as well as the insulating properties of accessories.

The increased-risk environments for welding processes may not necessarily coincide with the conducting locations with restricted movement (CLRMs), as defined in [11]. As an example, a conductive storage tank, which is isolated from ground, restricts the physical movements of a person working in it, but it is not a CLRM due to its isolation from ground. However, for the purpose of arc welding, the same storage tank does fall into one (or more) of the aforementioned increased-risk environments, and should be, therefore, treated as such by employing risk mitigation strategies.

IV. OPERATIONS WITH MULTIPLE WELDING MACHINES

Welding machines with different power sources may simultaneously be used on one workpiece (e.g. pipelines).

Some welding processes may require dc welding machines to use both polarities, that is, the electrode can be connected to either the positive pole or the negative pole of the welding

machine² (Fig. 4).

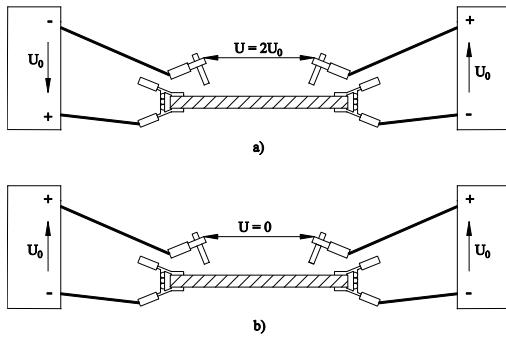

Fig. 4 Multiple welding machines in dc welding process

As shown in Fig. 4a, the no-load voltages between electrode holders may become two times the machine nominal voltage, according to the output polarities of the welding machines.

In ac welding processes, the welding machines may be distributed among the phases of the supply circuit, and the output instantaneous polarities may not be the same for each machine (e.g. the electrode is connected to positive in one machine and negative to another) (Fig. 5).

Also in the cases shown in Fig. 5, the no-load voltages between electrode holders may become two times the machine nominal voltage. In the case of three-phase supply, if welding machines are connected to different phases (e.g. L1-L2 and L1-L3), the summation of no-load voltages will always be non-zero. Similar potential differences will also occur if both ac and dc welding are performed simultaneously on the same structure.

The above described hazardous situations imposed by dc process requirements, or ac supply circuit constraints, and expose welders to the risk of electrocution if in simultaneous contact with electrodes of different machines.

Operators must address this hazard by:

- being aware of the risk;
- never touching simultaneously two electrode holders or electrodes;
- working out of reach of each other.

The non-zero summation of no-load voltages can be avoided for ac machines, by reversing either the welding cables, or the supply cables, whereas for dc machines preventing welding terminals from having different polarities.

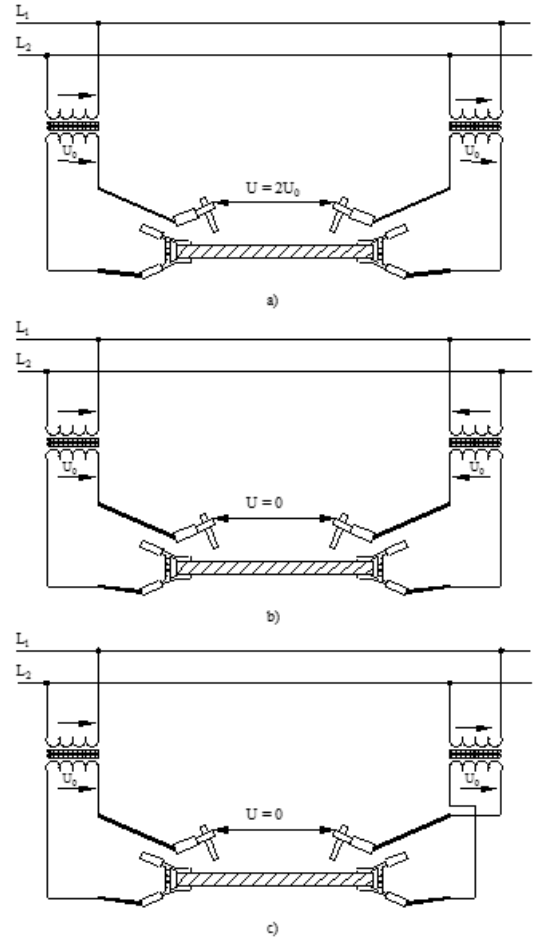

Fig. 5 Multiple welding machines in ac welding process

V. STRAY WELDING CURRENTS

Stray welding currents are substantial electrical currents (e.g. hundreds of amperes) that return to the source not only through the intended path (i.e. the return cable), but also through alternative routes. Stray currents can cause electric shock, burns, damage to property, and trigger explosive atmospheres, as well as fires.

Objectionable paths may be created when the return clamp is not as close as practical to the welding area, or to the workpiece; in this case stray currents circulate through larger portions of the workpiece, and possibly through the bench on which it rests; this may damage the workpiece (e.g. bearings of a machine).

Stray currents are likely if the welding return path exhibits a high resistance R (e.g. return clamp is attached onto a rusty surface), and the return cable has insulation defects (Fig. 6).

² A positive electrode provides the deepest welding penetration, whereas, a negative electrode provides a greater deposition rate.

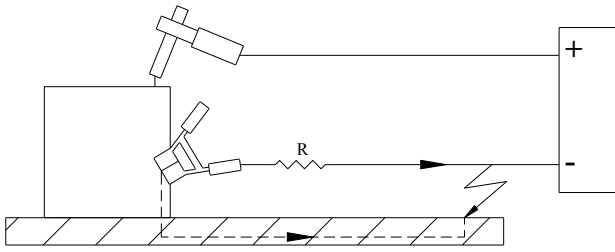

Fig. 6 Stray current due to high resistance return path, and insulation defects

If the workpiece being welded on is grounded (e.g. pipework installations) clamping the welding return to other grounded elements (e.g. frame of the building) should be avoided, unless they form part of the workpiece itself (Fig. 7).

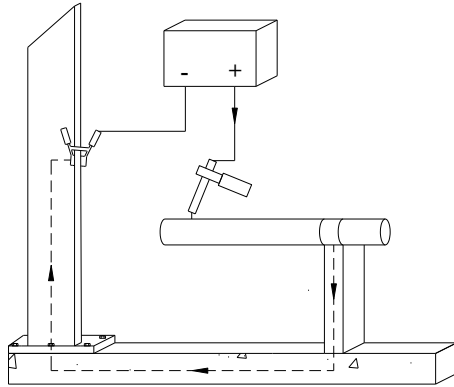

Fig. 6 Stray current due to clamp connection to grounded member

In the above case, the stray current may weaken load-bearing structures with grave risk for persons.

VI. ASSESSMENT OF ELECTROMAGNETIC FIELDS PRODUCED BY ARC WELDING EQUIPMENT

A. Methods

Arc welding equipment produce low-frequency electromagnetic fields that may adversely affect sensory and muscle function of the exposed workers; this may lower workers' ability to work safely.

For arc welding processes, the magnetic field is the most significant component of risk, thus an assessment of its magnitude against safe exposure limits as per [12], [13], [14], [15], [16] is necessary and mandatory for employers.

The standard EN 50444 [12] proposes the assessment procedure based on numerical calculations based on the ICNIRP guidelines. It is worth noting that the ICNIRP updated the guidelines concerning the low frequency range in 2010 [16]. However, many countries still have a regulatory framework based on the old guidelines published in 1998 [15].

In this paper both guidelines are therefore, considered.

The first noticeable difference between the two guidelines is the introduction of less stringent safe exposure limits in the new version. For brevity, in this paper we will only recall the levels related to the external magnetic fields, which are summarized in Fig. 7. The increase of the limit values starts at 25 Hz, and is based on a better understanding of the effects of the magnetic fields on persons, which allowed the reduction of the safety factors.

In addition, the latest guidelines have also changed the main dosimetric quantity to be in-situ electric fields, whereas the current density was previously considered. The major biological interaction that is now taken into account is in fact the electro-phosphenes, which is directly related to in-situ electric fields [16]

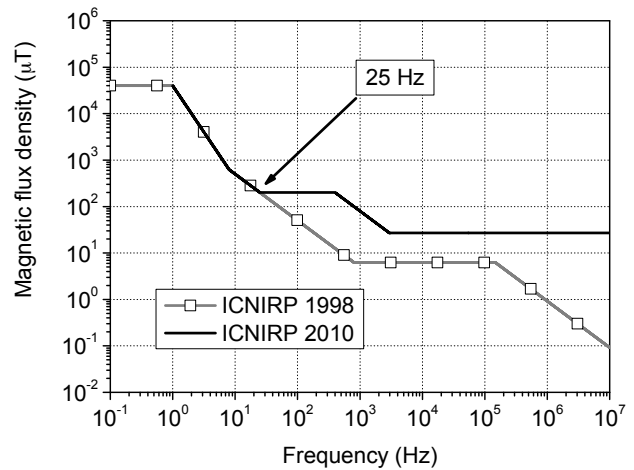

Figure 7: Comparison of the ICNIRP reference levels for exposure of the population to time-varying magnetic fields.

ICNIRP guidelines provide for a two-step procedure: the magnetic flux density is compared with the reference levels; in case of non-compliant values, the exposure is assessed against the basic restrictions, i.e. field quantities that determines health effects.

For pulsed or non-sinusoidal magnetic fields the assessment is not straightforward, as safe limits cannot be easily quantified due to the presence of a complex spectrum. Arc welding equipment generates a magnetic field waveform well defined, as it is proportional to the welding current regulated by the machine. The ICNIRP classifies these kind of waveforms as coherent, and suggests their assessment via the weighted peak method (WPM) [16], [17], [18]. The different spectral components must be independently analyzed and results must be added up according to the following formula:

$$|\sum_i W F_i A_i \cos(2\pi f_i t + \theta_i + \varphi_i)| \leq 1 \quad (1)$$

where

- A_i is the amplitude of the field (measured/computed) at the frequency f_i ;

- θ_i is the phase angle of the field (measured/computed) at the frequency f_i ;
- WF_i is the weight function at the frequency f_i ;
- φ_i is the phase angle of the weight function at the frequency f_i ;

A_i denotes a general quantity that can represent either an external field (e.g. B-field) or an induced field (e.g. J-field or E-field). WF_i is defined as the inverse of the limit at the frequency f_i . φ_i is provided by means of tables in the ICNIRP guidelines depending on the quantity A_i to be weighted.

When the current source is known, the standard EN 50444 [12] defines the assessment parameters for the numerical simulations. In particular, the welding cable pathway is fixed and its closest point to the body trunk is set to 20 cm [12]. Fig. 8 shows the anatomical body model named Duke [19] located in proximity of the welding cable according to the Annex A of [12]. The color map refers to the magnetic flux density values produced by a 100 A current.

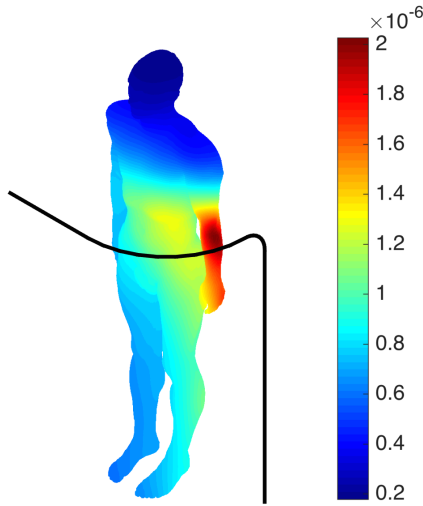

Figure 8: Relative position between the anatomical body model and the welding cable according to [12]. The color map refers to the magnetic flux density produced by a 100 A current.

The anatomical body model belongs to 34 years old man (height 1.804 m, weight 72.8 kg). It is obtained by segmentation medical imaging (i.e. magnetic resonance) and it is made of elementary $2 \times 2 \times 2 \text{ mm}^3$ brick elements called voxel (i.e. volumic elements) [19].

B. Description of the welding current

The current related to arc welding process is a waveform with trapezoidal shape [20]. In this paper we consider an ideal trapezoidal waveform (Fig. 9). According to the work of Mair [20] the trapezoidal waveform is characterized by the following parameters: rise-time (τ_r) 0.4 ms, pulsewidth (τ) 1.7 ms, fall-time (τ_f) 1 ms and period (T) 4 ms. The current peak (I_p) is set to 450 A.

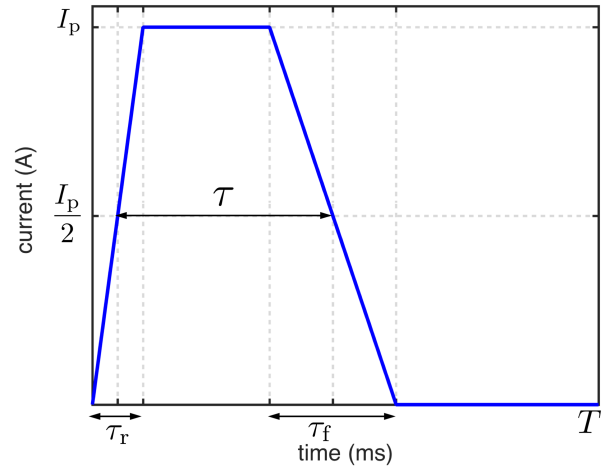

Fig. 9 Ideal trapezoidal waveform used to represent the welding current.

The spectrum of the welding current is shown in Fig. 10. The spectral resolution is 250 Hz for a period of 4 ms. It can be observed that the harmonic content beyond 5 kHz is negligible.

C. Results

The first analysis refers to the magnetic flux density generated by the welding device. By means of the model previously described, the magnetic flux density is computed for each voxel of the human model. For each tissue the maximum value (i.e. the peak of the waveform) is identified, and the weighted peak method is applied considering the ICNIRP guidelines of 1998 and 2010 [15], [16]. The human model herein adopted includes 72 tissues; however, to improve the readability of the results, some representative tissues of the peripheral nervous system (PNS) and of the central nervous system (CNS) were selected.

The results are shown in Fig. 11. The safe limit is exceeded (i.e. > 1) for all the selected tissues, if we compare to the old ICNIRP guidelines, whereas, with the latest guidelines, the limit is only slightly exceeded at the PNS tissues. In both cases it is therefore necessary to calculate the exposure quantities and their related exposure indexes.

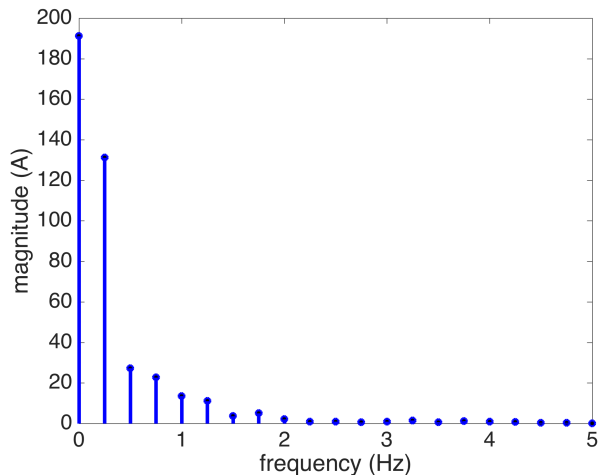

Fig. 10 Spectrum of the welding current

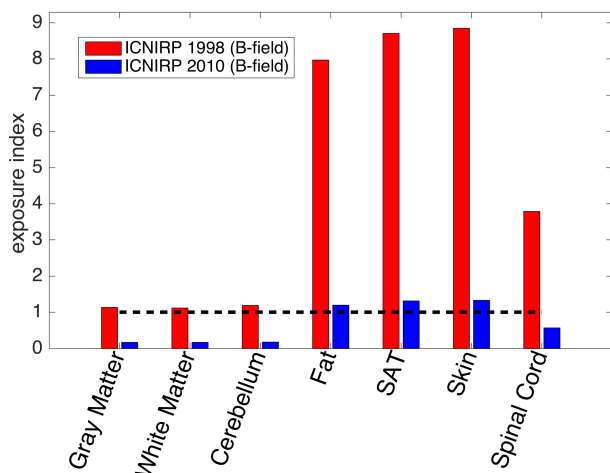

Fig. 11 Exposure indexes related to the B-field according to the old ICNIRP guidelines (1998) and the latest ICNIRP guidelines (2010).

The induced quantities are computed by solving a field problem for each frequency of the current spectrum. Since the spectrum is limited below 5 kHz, the quasi-static approximation is used [21], [22], [23], [24] and each field problem is solved by means of the scalar potential finite difference technique [25]. Once the spectrum of the induced quantity is known, the inverse Fourier transform is performed and the weighted peak method is applied again. The comparison of Fig. 12 shows that the exposure indexes are well below the limit (< 1).

In general, the new indexes included in the latest ICNIRP guideline have decreased with the only exception of the skin. This is likely due to the fact that the skin is a very thin tissue with low conductivity [26], which carries low values of current density. On the contrary, the skin can be subject to quite high values of electric field due to the continuity of its tangential component. The modeling of the skin is nowadays an open problem for the scientific community [27], [28], [29], [30].

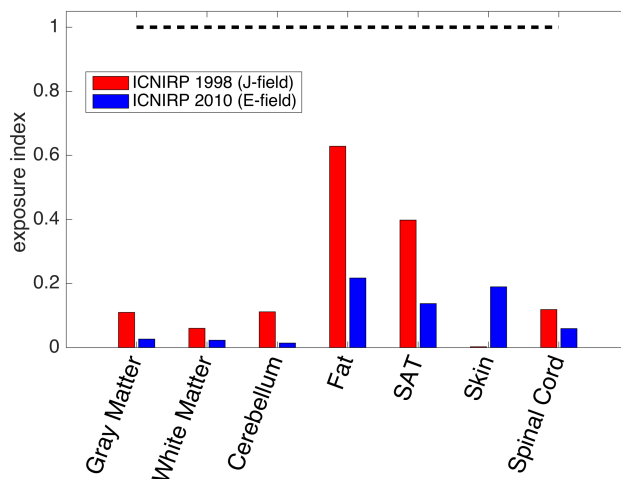

Fig. 12 Exposure indexes related to the J-field according to the old ICNIRP guidelines (1998) and to the E-field according to the latest ICNIRP guidelines (2010).

VII. CONCLUSION

In this paper, the authors have identified and discussed the risks to which arc welders may be subject, such as electric shock and exposure to intense electromagnetic fields generated from the arc welding equipment.

Operators may be working in special locations where the probability of electric shock is increased with respect to normal arc welding conditions (e.g. conducting locations with restricted movement), or because welding machines with different power sources are simultaneously used on a single workpiece. In addition, welders may inadvertently cause substantial stray currents through unintended paths, with grave risk of electric shock, burns, and damage to load-bearing building structures.

The authors have also performed an evaluation of the exposure of operators to electromagnetic fields. As a result, the case analyzed showed that the welding equipment was in compliance with ICNIRP guidelines: even though the reference levels for the B-field were exceeded, the basic safe limits for the J-field and the E-field were not exceeded.

REFERENCES

- [1] IEC 60974-13:2011 "Arc welding equipment - Part 13: Welding clamp".
- [2] IEC 60974-11:2010 "Arc-welding equipment: electrode holders".
- [3] IEC 60974-1:2012 "Arc welding equipment - Part 1: welding power sources".
- [4] OSHA Standard 1910.254: "Arc Welding and Cutting".
- [5] ISO 11611:2015 "Protective clothing for use in welding and allied processes".
- [6] ANSI/AWS Z49.1: "Safety in Welding, Cutting and Allied Processes". American Welding Society; 09-Mar-2012.

- [7] M. Mitolo, P. Montazemi: “*Electrical Safety in the Industrial Workplace: an IEC Point of View*”. IEEE Transactions on Industry Applications; Vol. 50, No. 6, November/December 2014; pages 4329-4335.
- [8] IEC 61140:2001 “Protection against electric shock –Common aspects for installation and equipment”.
- [9] IEEE Std P3003.2: “Recommended Practice for Equipment Grounding and Bonding in Industrial and Commercial Power Systems”; 2014.
- [10] IEC 60974-9: 2010-01 “Arc welding equipment – Part 9: Installation and use”.
- [11] IEC 60364-7-706:2005 “Low-voltage electrical installations – Part 7-706: Requirements for special installations or locations – Conducting locations with restricted movement”.
- [12] EN 50444:2008-02 “Basic standard for the evaluation of human exposure to electromagnetic fields from equipment for arc welding and allied processes”
- [13] EN 50445:2008 “Product family standard to demonstrate compliance of equipment for resistance welding, arc welding and allied processes with the basic restrictions related to human exposure to electromagnetic fields (0 Hz - 300 GHz)”
- [14] 1999/519/EC, Council Recommendation 1999/519/EC of 12 July 1999 on the limitation of exposure of the general public to electromagnetic fields (0 Hz to 300 GHz), Official Journal L199, 30.7.1999, pp. 59
- [15] ICNIRP, “Guidelines for limiting exposure to time varying electric, magnetic and electromagnetic fields (up to 300 GHz),” *Health Phys*, vol. 74, no. 4, pp. 494–522, 1998.
- [16] ICNIRP, “Guidelines for limiting exposure to time-varying electric and magnetic fields (1 Hz to 100 kHz),” *Health Phys*, vol. 99, no. 6, pp. 818–836, 2010.
- [17] K. Jokela, “Restricting exposure to pulsed and broadband magnetic fields,” *Health Phys*, vol. 79, no. 4, pp. 373–388, 2000.
- [18] ICNIRP, “Guidance on determining compliance of exposure to pulsed and complex non-sinusoidal waveform below 100 kHz with icnirp guidelines,” *Health Phys*, vol. 84, no. 3, pp. 383–387, 2003.
- [19] A. Christ, W. Kainz, E. Hahn, K. Honegger, M. Zefferer, E. Neufeld, W. Rascher, R. Janka, W. Bautz, J. Chen, B. Kiefer, P. Schmitt, H. Hollenbach, J. Shen, M. Oberle, D. Szczerba, A. Kam, G. J.W., and N. Kuster, “The virtual family – development of surface-based anatomical models of two adults and two children for dosimetric simulations,” *Physics in Medicine and Biology*, vol. 55, no. 2, pp. 23–38, 2010. P. Mair, “Assessment of EMF (Electromagnetic fields) and biological effects in arc welding applications, International Institute of Welding, Commission XII, Intermediate meeting, Fronius International, February 2005 Dawson T. W., Caputa K., Stuchly M. A., “Influence of human model resolution on computed currents induced in organs by 60 Hz magnetic fields”, *Bioelectromagnetics*, vol.8, pp. 478–490, 1997
- [20] P.P.M.So,M.A.Stuchly,andJ.A.Nyenhuis,“Peripheral nerves stimulation by gradient switching fields in magnetic resonance imaging,” *IEEE Transactions on Biomedical Engineering*, vol. 51, no. 11, pp. 1907–1914, Nov. 2004.
- [21] A. Canova, F. Freschi, L. Giaccone, and M. Manca, “A Simplified Procedure for the Exposure to the Magnetic Field Produced by Resistance Spot Welding Guns,” *IEEE Transaction on Magnetics*, vol. 52, no. 3, 2015.
- [22] A. Canova, F. Freschi, L. Giaccone, and M. Repetto, “Exposure of working population to pulsed magnetic fields,” *IEEE Transaction on Magnetics*, vol. 46, no. 8, pp. 2819–2822, 2010.
- [23] T. W. Dawson and M. A. Stuchly, “High-resolution organ dosimetry for human exposure to low frequency magnetic fields,” *IEEE Transactions Magnetics*, vol. 34, pp. 1–11, May 1998.
- [24] P.Hasgall, E.Neufeld, M.Gosselin, A.Klingenbo, and N.Kuster, “IT’IS Database for thermal and electromagnetic parameters of biological tissues.” www.itis.ethz.ch/database, September 26 2011.
- [25] De Santis V., Chen X. L., Laakso I., Hirata A., “An equivalent skin conductivity model for low-frequency magnetic field dosimetry”, *Biomedical Physics & Engineering Express*, vol. 1, n. 1, 2015
- [26] Schmid G., Cecil S. and Überbacher R., “The role of skin conductivity in a low frequency exposure assessment for peripheral nerve tissue according to the ICNIRP 2010 guidelines”, *Physic and Medicine in Biology*, vol. 58, pp. 4703–4716, 2013
- [27] De Santis V., Chen X. L., Cruciani S., Campi T. and Feliziani M., “A novel homogenization procedure to model the skin layers in LF numerical dosimetry”, *Physics in Medicine & Biology*, Vol. 61, pp., 4402–4411, 2016
- [28] Schmid G. and Hirtl R., “On the importance of body posture and skin modelling with respect to in situ electric field strengths in magnetic field exposure scenarios”, *Physics in Medicine & Biology*, Vol. 61, pp. 4412–4437, 2016

BIOGRAPHIES



Fabio Freschi (SM '13) received the Laurea degree (summa cum laude) in Electrical Engineering at the Politecnico di Torino in 2002. From 2003 to 2005 he attended the Doctorate School in Electrical Engineering at the Electrical Engineering Department of the Politecnico di Torino. On April 2006 he obtained the PhD degree and the European Doctorate Degree in Electrical Engineering. In 2006 he was visiting researcher at the Technical University of Graz (Austria). From January 2005 to July 2007 he was research assistant at the Electrical Engineering Department of the Politecnico di Torino. In 2013 he was visiting academic at The University of Queensland (Australia). He is currently working as assistant professor in Fundamentals of Electrical Engineering at the Politecnico di Torino. His main research and scientific interests are related to numerical modelling and computation of electromagnetic and bioelectromagnetic fields. Part of his activity is related to the study and development of deterministic and stochastic optimization algorithms applied to the study of electromagnetic devices and complex energy systems. He is author of more than 100 conference and journal papers in these fields. He is investigator of several of national and international research projects. He also serves as an Associate Editor for the IEEE Power Systems Engineering and he acts as referee of many international journals in the field of numerical electromagnetics, optimization and operational research.



Luca Giaccone (SM '15) was born in Cuneo, Italy, in 1980. He received the Laurea degree and the Ph.D. degree in Electrical Engineering from the Politecnico di Torino, Turin, Italy, in 2005 and 2010, respectively. Dr. Giaccone worked on several areas of the electrical engineering: optimization and modeling of complex energy systems, computation of electromagnetic and thermal fields, energy scavenging, magnetic field mitigation, EMF dosimetry, compliance of LF pulsed magnetic field sources. Since 2011 he is assistant professor with the Politecnico di Torino, Dipartimento Energia. He is member of the IEEE since 2014 and he has been elevated to senior member in February 2015. Since November 2015 he is member of the IEEE International Committee on Electromagnetic Safety - Technical Committee 95 - Subcommittee 6 that works in the field of EMF Dosimetry Modeling.



Massimo Mitolo (IEEE SM '03) received the Doctoral degree in Electrical Engineering from the University of Naples "Federico II," Naples, Italy. He is a registered Professional Engineer in Italy and is currently working as an Advisory Engineer at Eaton Corp. in Irvine, CA, USA. Dr. Mitolo authored over 70 journal papers and the books *Electrical Safety of Low-Voltage Systems* (McGraw-Hill, 2009) and *Laboratory Manual for Introduction to Electronics: A Basic Approach* (Pearson Prentice-Hall, 2013). His research interests include the analysis and grounding of power systems.

Dr. Mitolo is active within the Industrial and Commercial Power Systems Department of the IEEE Industry Application Society, where he is currently the Department Secretary, the Chair of the Power Systems Analysis Subcommittee, and the Chair of the Grounding Subcommittee. He also serves as the Treasurer of IAS, as well as an Associate Editor for the IEEE Power Systems Engineering and Energy Systems Committees with ScholarOne Manuscripts.

Dr. Mitolo has been the recipient of 16 awards, among which the 2012 IAS I&CPS *Ralph H. Lee* Department Prize Paper Award, and the 2013 *OCEC James E. Ballinger Engineer of the Year* Award.