

Product lifecycle management competitive technology solution

Original

Product lifecycle management competitive technology solution / Gecevska, Valentina; Cus, Franc; Lombardi, Franco; Chiampo, Fulvia - In: Towards technical education on resource savings for industrial development / Cus F., Chiampo F., Lombardi F., Gecevska V.. - STAMPA. - Maribor : Faculty of Mechanical Engineering, University of Maribor (Slovenia), 2015. - ISBN 978-961-248-488-0. - pp. 183-197

Availability:

This version is available at: 11583/2628881 since: 2016-10-27T09:39:14Z

Publisher:

Faculty of Mechanical Engineering, University of Maribor (Slovenia)

Published

DOI:

Terms of use:

This article is made available under terms and conditions as specified in the corresponding bibliographic description in the repository

Publisher copyright

(Article begins on next page)

PRODUCT LIFECYCLE MANAGEMENT COMPETITIVE TECHNOLOGY SOLUTION

**Valentina GECEVSKA, Franc CUS,
Franco LOMBARDI, Fulvia CHIAMPO**

1. INTRODUCTION

Product Lifecycle Management (PLM) is the process of managing the whole life cycle of a product starting from generating an idea, concept description, business analyzes, product design and solution architecture, technical implementation and product testing, to the successful entrance to the market, service, maintenance and product improvement. PLM gathered and make accessible all the data and information of all stages of this process. It is recognized as one of the key leading technologies to facilitate companies to overcome a lot of challenges, which will offer companies a new way to rapidly plan, organize, manage, measure, and deliver new products or services much faster, better, and cheaper in an integrated way.

In second part of this chapter, it is presented one of the most widely-used PLM solution suites in the market, Siemens PLM software-Teamcenter, solution built on the latest IT technology where all modules share a common data model and database. It is designed to enable Siemens PLM and its customers to configure and more easily expand Teamcenter's functionality today and in the coming years.

Valenina GECEVSKA, Faculty of Mechanical Engineering, University Ss.Cyril and Methodius, Karpos II bb, Skopje, 1000, MACEDONIA, valentina.gecevska@mf.edu.mk; Franc CUS, Faculty of Mechanical Engineering, University of Maribor, Smetanova 17, Maribor, SLOVENIA, franc.cus@um.si; Franco LOMBARDI, Politecnico di Torino, Corso Duca degli Abruzzi 24, Torino, ITALY, franco.lombardi@polito.it; Fulvia CHIAMPO, Politecnico di Torino, Corso Duca degli Abruzzi 24, Torino, ITALY, fulvia.chiampo@polito.it.

1.1. Idea for Product Lifecycle Management

The need to improve product innovation, product development, and engineering performance is leading many companies to adopt or extend Product Lifecycle Management (PLM) solutions. These solutions have proven value in helping manufacturers improve their product innovation, product development, and engineering performance – and ultimately the profitability of their products.

To be competitive in the current world economy, companies need a PLM strategy centered on an integrated product model that incorporates manufacturing data. To enable such a system, the company needs a software infrastructure – a layer that interfaces with the operating system. PLM applications come next, and these break down into two layers – a pure application layer and a layer of common components that apply across PLM, where configuration and document management belong. Those things typically thought of as PDM applications.

However, many companies struggle with the best way to transform their business and take advantage of these enabling PLM technologies. For any technology to provide a business benefit, it has to allow companies to change the way they do business so that they are more competitive, reduce business risk, increase revenue, decrease cost, or in some other way recognize tangible business advantage. Companies need to closely collaborate with customers, manufacturers, and suppliers in a real time manner so as to quickly respond to dynamic market changes.

Key technologies to support these business models have changed as well from mass production, to a flexible manufacturing system, to manufacturing knowledge management, to product customization, to product knowledge management, and to product lifecycle management (PLM) [1,2,3,4,5]. As such, PLM is recognized by world's leading universities, institutes, and solution vendors as the next big wave in enterprise application software.

2. PLM AS A BUSINESS STRATEGY

People often describe Product Lifecycle Management (PLM) as a technology. It is more appropriately described as a strategy for making companies more innovative and productive by applying a number of technologies [8,9]. These tools enable manufacturing companies to capture, use, and build upon the intellectual property created by design and manufacturing engineers, and to do so all the way from the concept of a product to the end of its life.

PLM is about more than product design. To be competitive in the current world economy, companies need a PLM strategy centered on an integrated product model that incorporates manufacturing data. To enable such a system, the company needs a software infrastructure – a layer that interfaces with the operating system. PLM applications come next, and these break down into two layers – a pure application layer and a layer of common components that apply across PLM, where configuration and document management belong, those things typically thought of as PDM applications.

PLM provides customers, developers, manufacturers, and suppliers with the most effective means of collaboratively managing business activities throughout product development. PLM supports the capability of innovation, creation, management, share, and use of product data, information and knowledge in virtual enterprise networks by integrating people, processes, and technology.

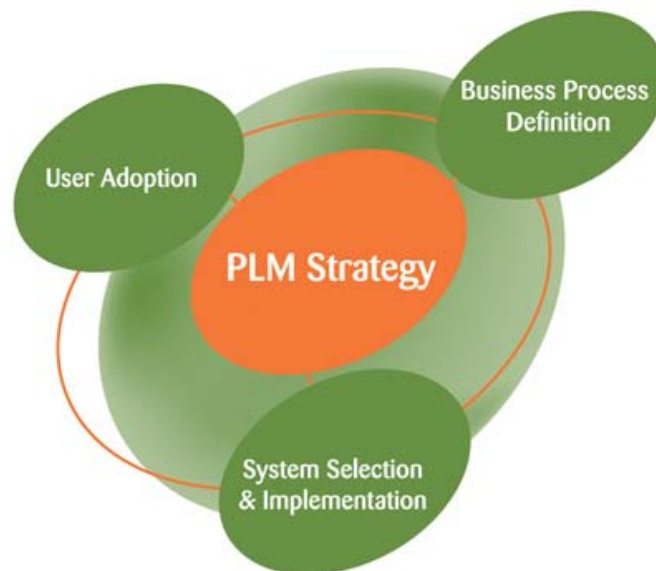

Figure 1. *PLM strategy*

PLM systems manage a portfolio of products, processes, and services from its initial conception, through design, manufacture and supply, to service and disposal. Throughout the entire product lifecycle (Ming, Yan 2005), there exist three major objectives, which are: customer benefit such as product quality and serviceability, company benefit such as product cost and profit, and society benefit such as clean and green environment.

To reach customer benefits, mass customization, time-to-innovation, product quality, and reliability are recognized as the key approaches enabled with technologies e.g., product family design, platform based design, modular product design, design process modeling and management, design knowledge management, collaborative design engineering, function/ behavior/ structure design, etc.

To achieve company benefits, time-to-market, time-to-volume, and time-to-profit are known as the key approaches enabled with technologies, e.g., collaborative product service, product lifecycle process management, product lifecycle information and knowledge management, etc.

To obtain society benefits, design for service, design for reuse, design for recycle are justified as the key approaches enabled with technologies, e.g. product/ service co-design, collaborative early design for lifecycle efficiency, environmentally conscious design, etc.

To effectively manage these product lifecycle processes for competitive advantages via efficient collaboration, technology solutions for PLM are proposed as the future trend. Accordingly, the impacts of PLM technology solutions to industry are analyzed.

3. APPLICATION OF PLM

3.1 Establishing PLM

There are companies that supply software to support the PLM process. That software itself is just a tool and cannot make many contributions if the PLM process is not defined first and understood by its users whom it should contribute to at the end. Setting up PLM within the company is a process and project itself.

Select operations that should be managed as a part of the PLM across the company business would be:

- Customer relationship management (CRM) system for managing customer record,
- Enterprise resource planning (ERP) system for managing financial records,
- Supply chain management (SCM) system for managing supplier support,
- Human resource management (HRM) system to manage the employee record,
- Requirement management (RM) system for managing of requirements,
- Project management (PM) system for managing capabilities provide project scheduling, tracking, and resource management while the change management is driving the execution of these projects via the process workflows and part/document management capabilities.
- Product Data Management (PDM) system for managing product data and workflows.

Fist step in establishing PLM would be understanding and analyzing the company way of work, organizational structure, roles and responsibilities within the organization. Each of the PLM operational systems should be defined to specify who is contributing to the system, how the information is shared and

responsible person appointed for each of the systems. It is not necessary that all those operation systems are integrated within one software tool, and usually for small and medium companies they won't be, while on the other side big companies might need to adopt available software and tools to their specific needs.

3.2 Application of PLM in small, medium and large enterprises

Small and medium enterprises have special needs and limited resources. PLM concept brings a complete solutions designed specifically for them; solutions that help them respond better to their customer's needs.

Small businesses need a product lifecycle management solution designed from the ground-up –one that is pre-configured with the industry's best practices, and offers fast and affordable deployment. Fully integrated PLM solutions are designed to provide what small and medium enterprises need to maximize their innovation strategy, and easily scale to meet their needs tomorrow.

One producer of that type of PLM software solutions is Siemens PLM software. It helps mid-sized manufacturing companies to transform their process of innovation by applying preconfigured best practices to everyday engineering tasks and processes. Companies using PLM software benefit from:

- Securing their corporate design data while facilitating access by authorized personnel
- A more successful move from 2D to 3D
- Increasing their design reuse, facilitated by a powerful and flexible search capability
- Streamlining their engineering process with simple design review and release workflows and effective change management
- Error reduction through more effective collaboration between their departments and the elimination of mistake manual handoffs to manufacturing
- Rapid deployment of a full-featured product data management (PDM) solution
- Low total cost of ownership.

In the current economic climate, addressing global business challenges is the top priority of most medium and large enterprises. Whether they want to expand their customer base in new markets, or to leverage more cost competitive resources, conducting their business globally is a necessity. To sustain an advantage, they have to overcome the challenges of a dispersed organization, while still empowering individual team members.

PLM concept offers comprehensive solutions to help enterprises address their challenges and create competitive advantage. Five areas where medium and large enterprise should have achieved success include:

- Managing new product introduction, to create a winning product portfolio.
- Achieving concurrent engineering globally, to be faster to market.
- Creating platforms for reuse, to reduce cost and speed product customization.
- Managing product and manufacturing complexity, to avoid program problems.
- Supporting products currently in-service, to ensure they are available for use at minimum cost.

4. BENEFITS OF PLM SOFTWARE

PLM software can help the companies to improve their understanding of how products are designed, built and serviced. Most users appreciate centralized access to all product-related information, they feel more productive and efficient. The benefits of PLM software focus around time, cost and quality. These benefits include: Faster time-to-market, Improved cycle times, Fewer Errors, Better product quality, Decreased cost of new product introduction, Insight into critical processes, Improved communication, Reduced product cost and greater profitability, Better resource utilization, Improved integration and communication with extended supply chain Less scrap & rework, Greater productivity, Greater Design efficiency, Better reporting and analytics, Standards and regulatory compliance, Improved design review and approval processes etc.

4.1 Increase profitable growth

PLM allows the enterprise to create, capture and share the product-related requirements, expectations and preferences of targeted customers and markets and align these requirements with specific innovative content that customers want for a price they can afford at the time when it is needed (Szykman, Sriram, Regli, 2001). PLM concept gives new product ideas against quickly rising customer requirements and cost effective manufacturability. Global cross-functional teams collaborate in real time on the development process, each contributing their unique experience and perspective. Knowledge and “lessons learned” are captured for potential re-use in a process of continual innovation. PLM facilitates mass customization by enabling to rapidly and costs effectively deliver customized product offerings that satisfy the needs of individual customers and targeted market segments. PLM combines the advantages of configuration management with option and variant management. These state-

of-the-market capabilities allow the enterprise to perform portfolio planning in as flexible and continuous a process as possible.

4.2 Reduce build costs

PLM allows the enterprise to reduce cost across all of the stages in the product lifecycle – which in turn, enables to minimize the cost of the product offerings that plan, develop, manufacture, and support.

For example, by leveraging PLM to understand the time and resource impacts of proposed design changes and requirements changes, the enterprise's team can make decisions that minimize lifecycle and product costs. By using PLM to catch design flaws up front in the lifecycle, the team can avoid the cascading rework and cost associated with changing the products during the manufacturing stages of the product lifecycle. Also, the enterprise's team can use PLM to incorporate the concerns of the maintenance and service groups into the product designs and minimize warranty costs. By digitally creating and re-using the manufacturing plans, plant information and manufacturing processes, the enterprise can reduce the overall operational costs. The enterprise can also use PLM to implement virtual prototyping that enables to reduce the validation costs associated with physical prototyping.

Implementation of the PLM concept in the enterprise enables to cost effectively deliver product enhancements, derivatives, niche offerings and add-ons that extend the profitable duration of the product lifecycle. PLM facilitates this objective by enabling to create product platforms that accelerate start up processes, minimize take to market cost and maximize the revenue generated by a product's initial release.

PLM enables the enterprise to maximize the re-use of the best-practice processes, intellectual capital, human resources, product plans, production plans, production facilities and value chains across a continuing set of take-to-market programs and complete set of product and production management capabilities.

5. SIEMENS PLM SOFTWARE

Siemens PLM, with headquarters in Plano, Texas, is a business unit of the Siemens Industry Automation Division. The Siemens Industry Automation Division (Nuremberg, Germany), a division of the Siemens Industry Sector, is a worldwide leader in the fields of automation systems, lowvoltage switchgear, and industrial software. Its portfolio ranges from standard products for the manufacturing and process industries, to solutions for whole industries and systems that encompass the automation of entire automobile production facilities and chemical plants. Siemens AG finalized its acquisition of UGS PLM

Solutions (UGS) in May 2007. Siemens PLM has a long history in the PLM market and is a global supplier of PLM solutions with offices and customers around the world. Siemens PLM provides one of the broadest and deepest suites of PLM offerings in the industry today, and has continued an aggressive program of acquisition and partnership to broaden their offerings even further. Additionally, they have continued to expand their business into new areas and have established a set of key systems integrator relationships to increase their focus on various geographies and industries. Siemens PLM reports that they have 63,000 customers in 62 countries, and they have 6.7 million licensed seats of PLM software of which 5 million are Teamcenter.

5.1 Teamcenter

Teamcenter 8, first released in March of 2009, is the culmination of many years of steady development and evolution of the Teamcenter suite by Siemens PLM. It is built on the latest IT technology with a unified SOA and all modules share a common data model and database [6, 7]. Teamcenter also contains fourteen functional areas, as it is shown of the Figure 2.



Figure 2. Teamcenter Functional Structure

The following paragraphs briefly describe the seventeen components of today's Teamcenter unified platform. Enterprise Knowledge Foundation provides the ability to capture and manage an extended enterprise's product definition information (i.e., the extended enterprise's intellectual assets)—integrating the organization's people, processes, systems, and data in a manner that enables all to collaboratively work together to define products and the processes necessary to define, build and/or assembly, maintain, and decommission and/or recycle.

Platform Extensibility Services deliver the ability to quickly and easily configure Teamcenter to support specific business and system integration requirements—not just when the solution is first implemented, but also in support of upgrades and general continuous improvement projects. The embedded Business Modeler Integrated Development Environment (BMIDE) is used to configure Teamcenter without having to write and support customized code. It can also be used to develop customer-specific integrations with other business systems that can be automatically upgraded as new Teamcenter releases are deployed.

Lifecycle Visualization enables people to view and work with both 2D and 3D product information. This capability is provided to users throughout the enterprise, suppliers, partners, and customers without the need for these people to own or know how to use the information authoring tools such as CAD.

Supplier Relationship Management (SRM) enables an enterprise to effectively manage and engage its supply chain to manage product costs and quality including supplier performance. It includes a disciplined and systematic process for reducing the total costs of externally purchased materials, goods, and services while maintaining and improving levels of quality, service, and technology and to evaluate, prioritize, and manage preferences for supplier utilization.

Mechatronics Process Management provides mechanisms that support coordinated management of centralized data, workflow, authoring tools, and process management for the integrated development of mechanical, electrical, electronic, and software components and systems as part of a single product, and to communicate this information appropriately throughout the organization.

Systems Engineering and Requirements Management (SERM) provides a mechanism to facilitate the capture and analysis of customer needs and then associate those needs with formal requirements (e.g., performance, maintainability, reliability, manufacturability, usability, and ergonomics characteristics) that the product and/or product-related processes must deliver. These requirements may be associated with the product across potentially all stages of the product lifecycle. SERM also provides mechanisms to outline and organize systems designs, in association with multiple product decompositions, and associate product requirements into the designs as appropriate for both initial product development and further enhancements and change process support.

Manufacturing Process Management (MPM) provides a mechanism to describe, simulate, optimize, and release manufacturing process plans and related definitions in collaboration with product design activities, and to communicate this information appropriately throughout the organization.

Simulation Process Management (SPM) provides mechanisms to integrate the creation, utilization, and management of simulation data and processes into

the context of the full product definition and PLM environment. This also includes the ability to capture and utilize best-practice analysis processes to provide consistency and effective simulation support to product development.

Maintenance, Repair, and Overhaul (MRO) enables companies to manage the maintenance, repair, and overhaul of complex products such as aircraft, ships, and plants throughout their lifecycle—from concept through to end-of-life (e.g., decommissioning). It provides knowledge of a product's configuration, its maintenance and repair history, how it can be serviced, and what spares, test, and service equipment must be used to maintain the product or system as well as capabilities to define, schedule, and track maintenance activities. Additionally, MRO supports claims and warranty management by providing capabilities necessary to define and manage processes specifically focused at handling those activities.

Reporting and Analytics includes the tools to collate, analyze, and produce data through pre-defined and ad-hoc reports, digital dashboards, and email for real-time sharing of business intelligence. It provides a basis for companies to establish, measure, and analyze key product related performance metrics to drive decisions and processes throughout the product lifecycle.

Community Collaboration provides a platform for sharing information and working together across the product lifecycle. Real-time collaboration and application sharing can be used to create an environment for product and process information to be communicated among all key participants in the product lifecycle. It provides capabilities to securely integrate product lifecycle management data from many different sources into one interface.

Engineering Process Management enables the overall management of the product design process and the resulting product definition information including the collaborative manage of all design process tasks and the process interaction with internal as well as external design supply chain partners. It supports the consolidation of product design and related information from multiple distributed sources within a single product data management (PDM) system and automation of engineering change, validation and approval processes. It supports multi-CAD data and the ability to aggregate design changes continuously.

Bill of Material (BOM) Management provides the ability to create and manage product structures and their multiple logical constructs. These products structures include part-to-part, part-to-document, and document-to-document relationships so that a complete bill of information (BOI) can be defined and managed throughout a product's and its associated information's lifecycles.

Compliance Management enables the definition, tracking, and reporting of all product-related information and activities required to confirm that a product meets regulatory compliance metrics. It is generally implemented with industry-specific solutions, e.g., Food and Drug Administration (FDA) compliance for

pharmaceuticals or medical devices. Compliance Management is also used to support tracking and managing export controlled product related information, e.g., International Traffic in Arms Regulations (ITAR).

Content and Document Management provides the ability to define, author, illustrate, manage, and deliver exact product information in the reader's preferred language and media. It supports and can be integrated with multiple authoring environments including Microsoft Office and CAD design applications. It can automatically update documents and other content when components of those items are changed. Content and document management provides full configuration management and change control of all elements, components and full documents.

Formula, Package, and Brand Management supports the ability to define and introduce to the market formula-based products, including their packaging, artwork, labels, claims, and other package and brand-related content. This includes the ability to manage formulas and configurations of formulas, specifications, mixing instructions, etc. that describe specific recipes and how they are to be produced. It includes the ability to define and manage a set of intelligent specifications that are interrelated and that describe the various components of a formula-based product including management of the physical package definition, its artwork, labels, claims, etc. For brand management it supports the management of logos, product and package photos, marketing material, etc.

Portfolio, Program and Project Management encompasses three areas—idea and concept, product portfolio, and project management. Idea and Concept Management enables organizations to capture ideas for new products or services, study their market potential and technical constraints, evaluate if, when, and how to efficiently produce them and then develop a short list of promising product concepts that match a company's strategy. Product Portfolio Management focuses on identifying, evaluating, and managing the "family" or portfolio of products that a company offers and maintains. It includes capabilities to compare product investment alternatives according to market demand, competitive pressures, macro-level cost rollups, project sales and profitability estimates, overall resource needs, status reporting (including visual dashboards), and other information and processes needed to enable a company to determine the best ideas and products in which to invest, build, and sustain. It combines and gives visibility into the financial, strategic, and operative aspects across the entire project portfolio to enforce governance, make fact-based decisions and maximize return on existing assets. Project Management enables project managers to control project structures, schedules, costs, and resources. This includes network planning techniques and aggregative tools that support cross-project cost, revenue, margin, schedule, and resource management.

5.2 Teamcenter application on a real product

In this article is present the application of Siemens PLM Software-Teamcenter. The main goal is to introduce the Teamcenter interface with some of its modules using a real product. The product is a transformer, made by the company “Sever” from Serbia. At the Figure 3 is shown the interface of the software using the transformer.

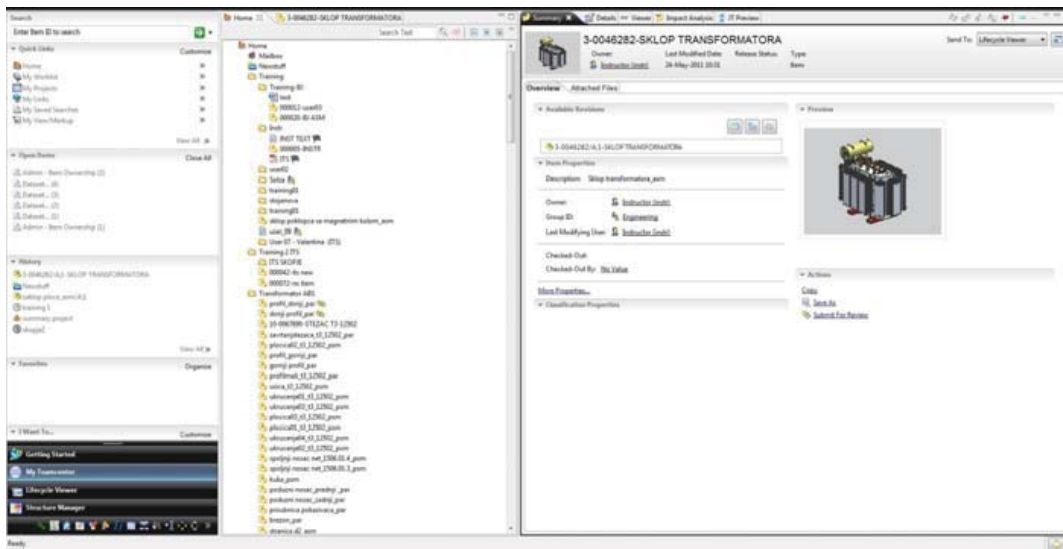

Figure 3. Teamcenter Interface

If you want to see the whole structure of the product, it is used the tool Relation browser. In Figure 4 is shown the structure of the transformer with some of its relations.

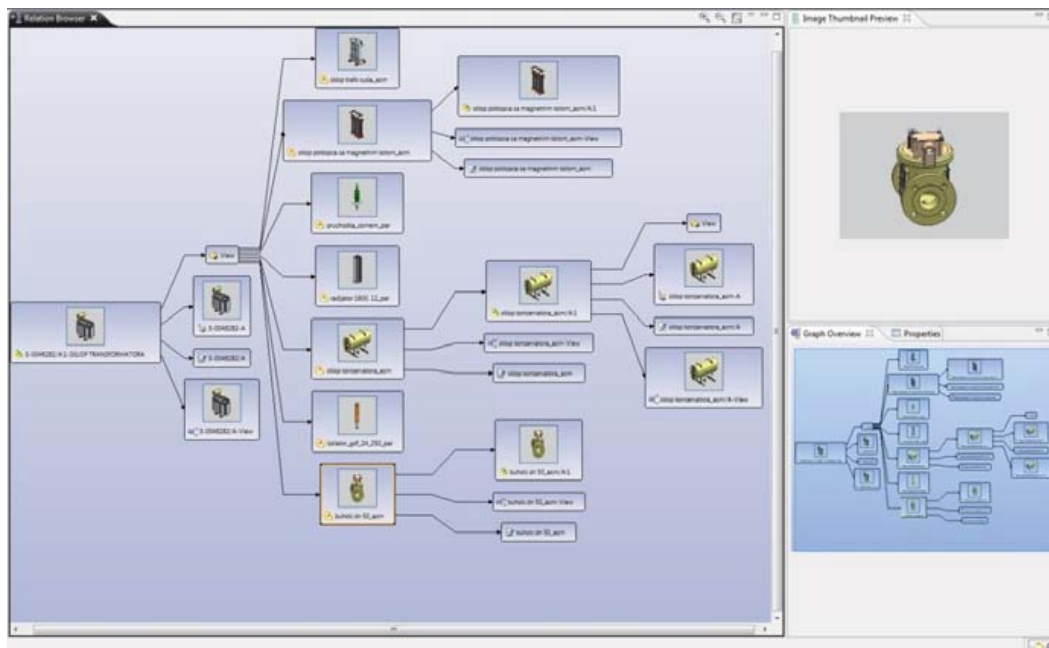

Figure 4. Teamcenter Relation Browser

With the Lifecycle Viewer tool, you can see the final model of the product as it is shown at Figure 5. If you want to see the transformer without some of its parts you should only switch off the icons of the parts in the left corner.

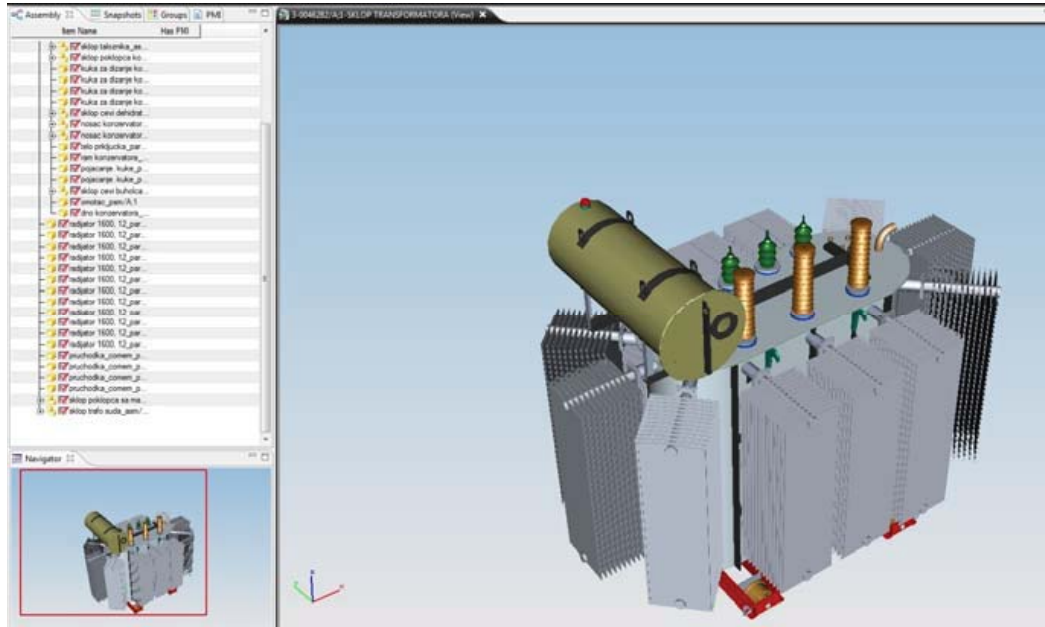

Figure 5. Teamcenter Lifecycle Viewer

All of the Teamcenter modules can be used to get better control of the whole product lifecycle. At Figure 6 and Figure 7 is shown the interface of Teamcenter Project and Requirements Manager.

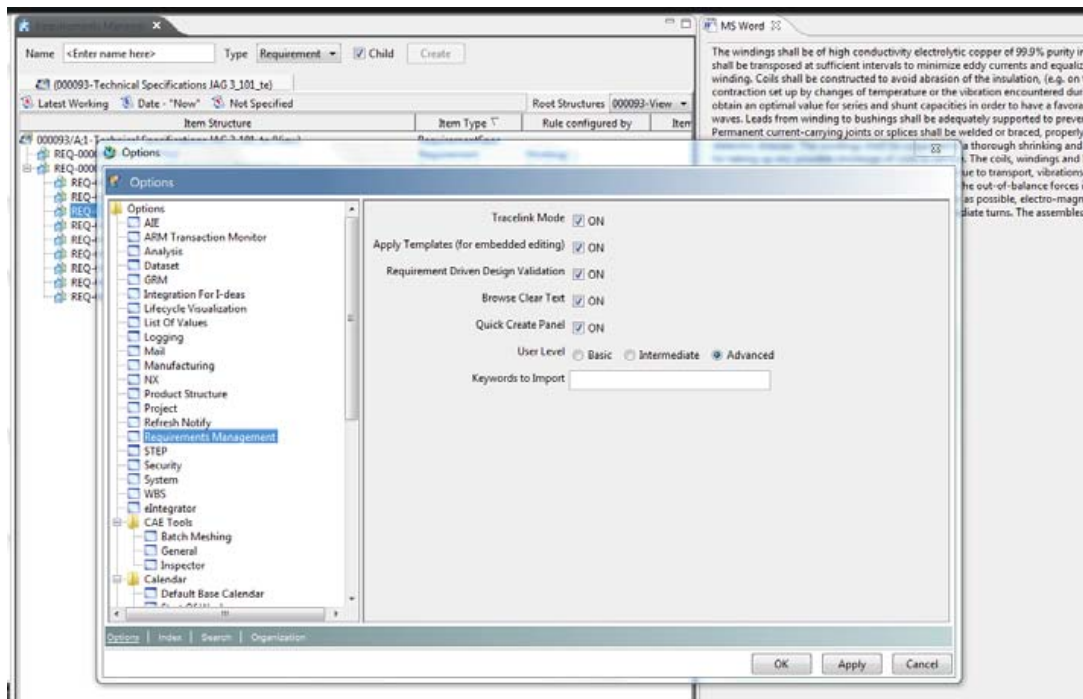

Figure 6. Teamcenter Requirements Manager

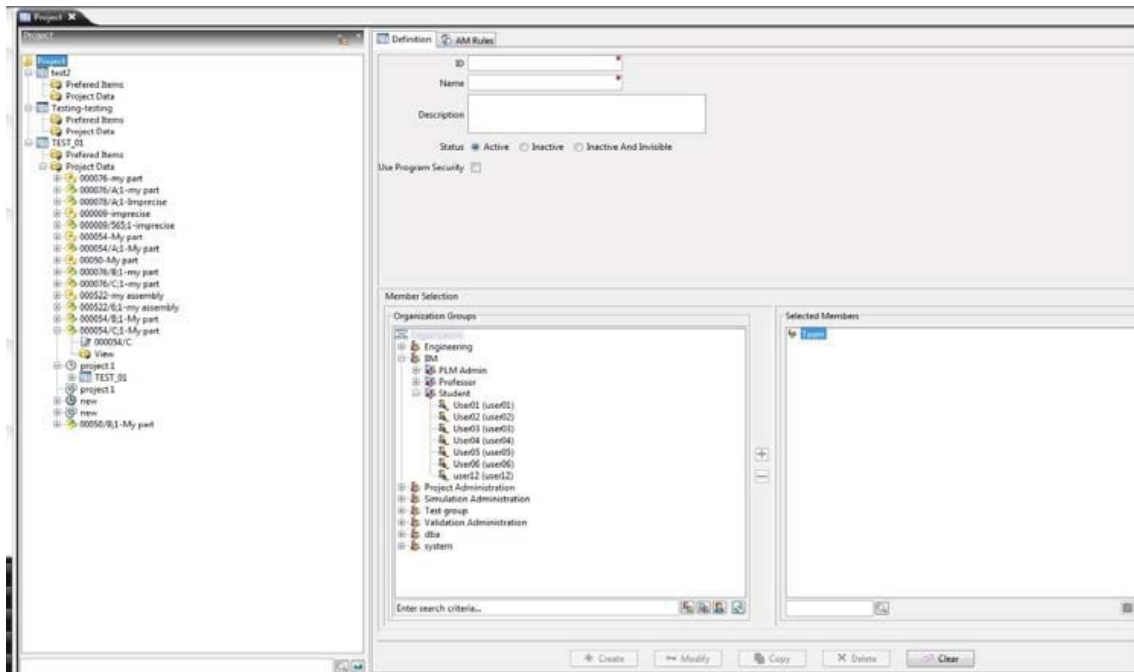

Figure 7. Teamcenter Project

Teamcenter software helps the costumers to get a lot of benefits. It enables to the enterprise to beat the competition to market with innovative product content that carries first to-market advantages and drives early product sales.

6. CONCLUSION

PLM has proven itself to be useful for all management levels in the companies. PLM is used both for those who are doing execution and decision makers within the organization answering to the rapid changes in the business environment. As an information technology strategy, PLM establishes a coherent data structure that enables real-time collaboration and data sharing among geographically distributed teams. PLM lets companies consolidate multiple application systems while leveraging existing legacy investments during their useful lives.

Teamcenter enables customers to maximize the power of their product knowledge and leverage it to increase the profitability and productivity of every stage in their product lifecycle. The companies which are using this software notice personal and team productivity, shorter time to market, increased product quality and minimized product and lifecycle costs.

REFERENCES

1. Pol, G., Merlo, C., Legardeur, J.: Implementation of collaborative design processes into PLM systems, *International Journal of Product Lifecycle Management*, Inder-science, Vol.3, No.4 (2008), pp. 279-294.
2. Saaksvuori A., Immonen A.: *Product Lifecycle Management*, Springer-Verlag, 2008.
3. Grieves, M.: *PLM: Driving the Next Generation of Lean Thinking*, McGraw-Hill, 2009.
4. Bernard A., Tichkiewitch S.: *Design of Sustainable Product Life Cycles*, Springer-Verlag, 2008.
5. Stark, J.: *PLM: 21st century Paradigm for Product Realisation*, Springer-Verlag, 2004.
6. CIM Data: *Teamcenter "unified": "Siemens PLM Software's Next Generation PLM Platform*
7. www.siemens.com/plm , Siemens PLM, 2009
8. Pol, G., Merlo, C., Legardeur, J.: Implementation of collaborative design processes into PLM systems, *International Journal of PLM*, Inder-science, Vol.3, No.4 (2012), pp. 279-294.
9. X. G. Ming, J. Q. Yan: Technology Solutions for Collaborative PLM - Status Review and Future Trend, *Journal Concurrent Engineering*, Vol.13, No.4, 2005, pp.311-321.
10. Gecevska V., Chiabert P., Anisic Z., Lombardi F., Cus F.: *Product lifecycle management through innovative and competitive business environment*, *Journal of Industrial Engineering and Management*, JIEM, 2010, Vol.3-2, pp.323-336.
11. Gareti M., Terzi S., Bertachi N., Branza M.: Organisational change and knowledge management in PLM implementation, *International Journal of Product Lifecycle Management*, Pub. Inder-science, Vol.5-1, 2011.