

2.5 Gbps 2-PSK ultra-dense WDM homodyne coherent detection using a sub-carrier based optical phase-locked loop

Original

2.5 Gbps 2-PSK ultra-dense WDM homodyne coherent detection using a sub-carrier based optical phase-locked loop / S., Camatel; Ferrero, Valter; Gaudino, Roberto; Poggiolini, Pierluigi. - (2004), pp. 357-363. (Intervento presentato al convegno OpNeTec 2004 tenutosi a Pisa, Italy nel October 18-20, 2004) [10.1007/0-387-23178-1_44].

Availability:

This version is available at: 11583/1415465 since: 2016-11-04T14:31:53Z

Publisher:

Springer US

Published

DOI:10.1007/0-387-23178-1_44

Terms of use:

This article is made available under terms and conditions as specified in the corresponding bibliographic description in the repository

Publisher copyright

(Article begins on next page)

2.5 GBPS 2-PSK ULTRA-DENSE WDM HOMODYNE COHERENT DETECTION USING A SUB-CARRIER BASED OPTICAL PHASE- LOCKED LOOP

S. Camatel, V. Ferrero, R. Gaudino and P. Poggiolini

*PhotonLab, Dipartimento di Elettronica, Politecnico di Torino, Corso Duca degli Abruzzi 24,
10129 Torino, Italy*

Abstract: We present an optical phase locked loop based on sub-carrier modulation and designed using commercial optical components. In principle the output of a continuous-wave laser is subcarrier modulated by a common LiNbO₃ MachZehnder driven by an electrical voltage controlled oscillator. The proposed architecture is used as optical receiver for homodyne coherent detection of ultra-dense WDM 2.5 Gbps 2-PSK signals with 6.25 GHz spacing. This method offers the potential for providing many closely spaced multigigabit channels and enables coherent lightwave technology to become commercially viable.

Key words: Multichannel Coherent Optical Communications, Homodyning, Phase modulation, Ultra Dense WDM, Optical PLL.

1. INTRODUCTION

The development of Ultra-Dense WDM (UDWDM) systems is currently under investigation for increasing the global capacity per single fiber. For example in [1], 10 Gbit/s transmission at 25 GHz channel spacing is demonstrated and studied in details. Anyway, it is shown in this and other works that optical filters for UDWDM have very tight requirements in pass-band shape and frequency stability. As described in [2] these requirements can be avoided using coherent communication systems which let

transmission of a large number of WDM optical channels with very narrow frequency separations. Another advantage of coherent transmission is the ability to select any particular channel by simply tuning a local oscillator. An optical phase-locked loop (OPLL) has then to be implemented in order to obtain a tunable local oscillator.

OPLLs for homodyne or heterodyne coherent detection received a great deal of attention at the beginning of the 1990s [3] in order to increase the receiver sensitivity, but they never found practical applications, first because of their complexity, secondly due to the introduction of EDFAs, that greatly leveraged sensitivity issues. We proposed in [4-6] a novel and much simpler OPLL architecture based on commercial off-the-shelf optoelectronic components and without fast direct laser frequency tuning. Frequency tuning is obtained in our system through optical sub-carrier generation and tuning, and will be indicated as SC-OPLL.

This paper presents a possible application of our SC-OPLL for demultiplexing and detection of UDWDM signals. We propose and demonstrate a receiver setup capable of detecting 2-PSK signals at 2.5Gbit/s and 6.25 GHz channel separation. Our setup does not require narrow optical filters, and can be an enabling technology for future optical networks.

2. SC-OPLL ARCHITECTURE

The SC-OPLL architecture is shown in Fig. 1. The Optical Voltage Controlled Oscillator (OVCO) is the key-element and is based on a commercial Continuous-Wave (CW) external cavity tunable laser at

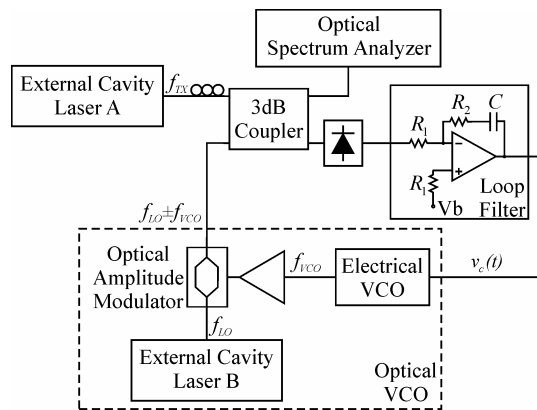

Figure 1. Schematic diagram of SC-OPLL.

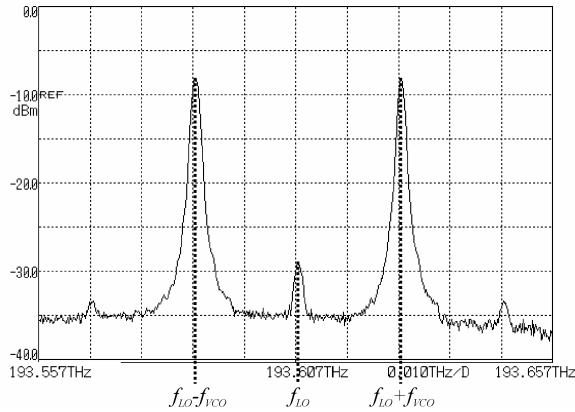

Figure 2. Spectrum at the output of the optical VCO.

frequency f_{LO} that is externally amplitude modulated by the signal coming from an electrical VCO at frequency f_{VCO} . By biasing the external Mach-Zehnder (MZ) amplitude modulator at a null of its transfer function, a sinusoidal carrier-suppressed modulation is obtained. The resulting spectrum at the output of the OVCO is shown in Fig. 2. Two main sub-carriers at frequency $f_{LO} \pm f_{VCO}$ are generated, with spurious optical tones at f_{LO} and $f_{LO} \pm 2f_{VCO}$ due respectively to a limited extinction ratio and nonlinearities of the amplitude modulator. Considering one of the two main sub-carriers, for example the one at $f_{LO} + f_{VCO}$, we are able to tune an optical frequency by simply changing the voltage applied to the electrical VCO, thus implementing an OVCO. Actually, this is the key issue of the proposed architecture, that allows obtaining optical fine frequency tuning with the speed and stability of an electrical VCO, and thus to re-use typical RF PLL set-ups. In our case, a standard second-order PLL control circuit allows to lock $f_{LO} + f_{VCO}$ to the transmitted signal at frequency f_{TX} (laser A in Fig. 1). When the OPLL is locked to $f_{LO} + f_{VCO} = f_{TX}$, optical homodyne is obtained, allowing to track the incoming optical signal frequency and phase.

When the incoming signal is modulated, its optical spectrum is translated to base-band at the photodiode output. In principle, due to beating with the other sub-carriers, copies of this signal appears also around frequencies f_{VCO} and $2f_{VCO}$, but they can be filtered out by the receiver filter if f_{VCO} is larger than the signal spectral width (or bandwidth). Other details of the setup can be found in Fig. 1. A polarization controller matches the polarization of TX and LO signals before being combined by a 3dB coupler and sent to an amplified photodiode. The resulting electrical signal is processed by a single-pole active filter, in order to obtain a second-order PLL with natural

frequency f_{loop} and the damping factor ξ [5], which both depend on the loop filter parameters $\tau_1=R_1C$ and $\tau_2=R_2C$.

3. ULTRA-DENSE WDM COHERENT DETECTION

An ultra-dense WDM optical transmission system has been experimentally set up in order to evaluate the performance of our SC-OPLL. The description of the system's design and the obtained results follow.

3.1 System setup

The system experimental setup is shown in Fig. 3, and is an UDWDM extension of the one presented in [4]. Three CW lasers at frequency f_0 (central channel) and $f_0 \pm \Delta f$ (adjacent channels) were optically multiplexed and sent to a LiNbO₃ external phase modulator, driven by an electrical NRZ 2.5Gbit/s PRBS signal to obtain a 2-PSK modulation. We used external cavity tunable lasers in order to be able to freely set the UDWDM channel separation Δf . The resulting optical signal, whose spectrum is shown in the upper part of Fig. 4, is sent to a variable optical attenuator (VOA) and then to an optical preamplifier. The resulting signal is then filtered by a 0.6 nm optical filter, which is used to reduce ASE noise, but is large enough to let the three channels pass through undistorted, i.e. this filter does not perform WDM demodulation. The coherent receiver is based on our SC-OPLL. The local oscillator frequency f_{LO} has been set such that the main sub-carrier $f_{LO} + f_{VCO}$ is able to lock the transmitted central channel frequency f_0 . The spectrum at the output of the OVCO has been represented in the lower part of Fig. 4 which graphically represents the desired locking condition. The 2.5

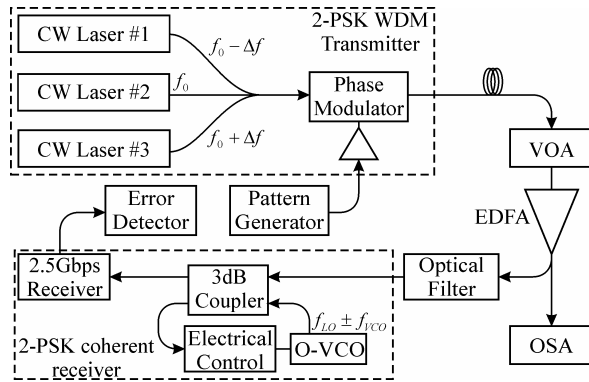

Figure 3. UD-WDM experimental setup.

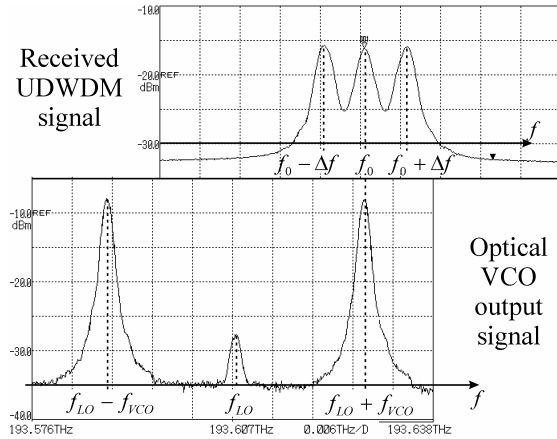

Figure 4. Spectra (0.01 nm resolution bandwidth) of the received UD-WDM signal (a) and of the OVCO output

Gbps receiver is a typical amplified photodiode and shifts the received WDM spectrum to base-band. Indeed, when the SC-OPLL is locked, the spectrum at the output of the photodetector includes a spectral component centered on zero frequency generated by the central channel and the contribution around Δf given by the adjacent two channels. UD-WDM channel demultiplexing and demodulation is directly obtained through the receiver electrical filters. In fact, a standard receiver filter such as SDH 4-poles Bessel filter at 1.8 GHz proved more than adequate to reject the two adjacent channels efficiently. In contrast, a standard DWDM receiver would demultiplex through optical filtering which is quite impractical at 6.25 GHz channel spacing.

In our experiment, we used a 2-PSK modulation with residual carrier, so that the SC-OPLL automatically locks to the 2-PSK residual carrier. For further details on this principle see [8]. The O-VCO contains an electrical VCO with $f_{VCO} = 20$ GHz and 5 GHz dynamic range, followed by a 40 GHz bandwidth LiNbO_3 amplitude modulator.

3.2 Experimental Results

The performances of our setup were tested by measuring the BER as a function of the OSNR (measured over 0.1nm resolution) for different channel spacing. The results are shown in Fig. 5 for Δf equal to 50, 6.25 and 5GHz. The curve for $\Delta f = 50$ GHz can be taken as a reference for a situation

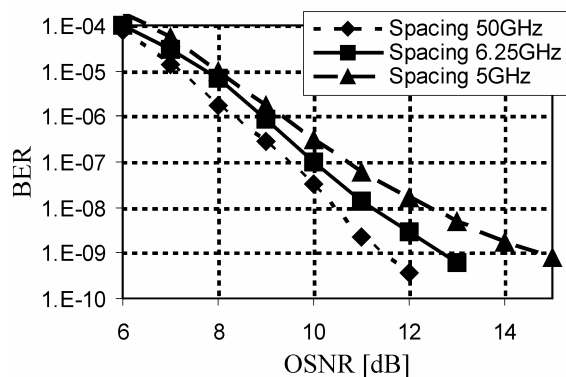

Figure 5. BER vs. received OSNR (0.1 nm resolution bandwidth) for 50, 6.25 and 5 GHz channel spacing values.

without WDM crosstalk. In fact, we verified that it does not show any penalty with respect to single channel transmission. The curve for $\Delta f = 6.25 \text{ GHz}$ shows a penalty smaller than 1 dB at $\text{BER} = 10^{-9}$. This result proves the feasibility of the proposed setup, even for 6.25 GHz channel spacing. The penalty becomes larger (more than 3 dB) for $\Delta f = 5 \text{ GHz}$, where the UD-WDM channel spectra significantly overlap, thus giving rise to an intrinsic, receiver independent, channel crosstalk. Please note that we do not use any particular signal shaping at the transmitter [7], so that $\Delta f = 5 \text{ GHz}$, i.e., twice the bit rate, is close to the theoretical limits (regarding bandwidth occupation).

In our experiment, due to hardware limitation, we used only three wavelengths at the transmitter side, which are anyway sufficient as a “proof-of-concept” of our technique. In a practical setup with many UD-WDM channels, when $f_{LO} + f_{VCO} = f_0$, the other SC-OPLL subcarrier at $f_{LO} - f_{VCO}$ could beat with another WDM channel. Anyway, this problem can be easily solved by using an optical filter with a passband of the order of $2f_{VCO}$, which could be significantly greater than Δf . In our experiment, we had 20 GHz, thus envisioning the use of a quite common 40 GHz bandwidth optical filter (tunable, if required by the network architecture).

4. CONCLUSIONS

We proposed a novel optical PLL architecture based on off-the-shelf optoelectronic components and we used it for coherent detection of 2.5 Gbit/s 2-PSK signals with 6.25 GHz spacing and 1 dB penalty for UDWDM

applications. The use of optical homodyning, greatly mitigates the requirements on optical filtering and enables channel spacing in the few GHz range. The price to be paid for optical homodyning is the receiver complexity. Anyway, most of the components required in our setup could potentially be integrated using next-generation optical circuits and devices, thus opening new possibilities for future optical transmission systems, and allowing at the same time a reduction in the costs.

ACKNOWLEDGEMENTS

This project was partially funded by CISCO, University Research Program (URP). The authors would like to thank S. Morasca (Avanex) for his invaluable support to the experiment.

REFERENCES

- [1] I. Lyubomirsky, T. Qui, J. Roman, M. Nayfeh, M. Y. Frankel and M. G. Taylor, "Interplay of Fiber Nonlinearity and Optical Filtering in Ultradense WDM", *IEEE Photonics Technology Letters*, vol. 15, no. 1, pp. 147-149, Jan. 2003.
- [2] R. E. Wagner, N. K. Cheung and P. Kaiser, "Coherent Lightwave Systems for Interoffice and Loop-Feeder Applications", *Journal of Lightwave Technology*, vol. LT-5, no. 4, April 1987.
- [3] L. G. Kazovsky and D. A. Atlas, "A 1320-nm experimental optical phase-locked loop: performance investigation and PSK homodyne experiments at 140 Mbps and 2 Gbps", *Journal of Lightwave Technology*, vol. 8, no. 9, pp. 1414-1425, Sept. 1990.
- [4] S. Camatel, V. Ferrero, R. Gaudino and P. Poggiolini, "10 Gbit/s 2-PSK Transmission and Homodyne Coherent Detection using Commercial Optical Components", *ECOC 2003*, paper We.P.122.
- [5] V. Ferrero, S. Camatel, R. Gaudino and P. Poggiolini, "A novel Optical Phase Locked Loop architecture based on Sub-Carrier modulation", OFC 2004, paper FN6.
- [6] S. Camatel, V. Ferrero, R. Gaudino and P. Poggiolini, "Optical phase-locked loop for coherent detection optical receiver", *IEE Electronics Letters*, vol. 40, no. 6, pp. 384-385, March 2004.
- [7] L. G. Kazovsky, S. Benedetto and A. Willner, *Optical fiber communication systems*, chap. 4, Artech House, 1996.
- [8] L. Kazovsky, "Balanced Phase-Locked Loops for Optical Homodyne Receivers: Performance Analysis, Design Considerations, and Laser Linewidth Requirements", *Journal of Lightwave Technology*, vol. LT-4, no. 2, pp. 182-195, Feb. 1986.