

ACTIVATION OF AN OPTICAL NETWORK UNIT IN A MULTI-WAVELENGTH PASSIVE OPTICAL NETWORK

Technical field

The present invention relates to the field of optical access
5 networks. In particular, the present invention relates to a method for
activating an ONU (Optical Network Unit) in a multi-wavelength PON
(Passive Optical Network) and to a multi-wavelength PON configured
to implement such a method.

Background art

10 As known, optical access networks provide end users with access
to several broadband services, such as for instance Internet access,
video-on-demand, telephone services, etc.

Among the known optical access networks, passive optical
networks (briefly termed PON) are becoming even more widespread.
15 Typically, a PON comprises an OLT (Optical Line Termination) and
an ODN (Optical Distribution Network) connected thereto. The ODN
comprises optical links and optical splitters (with typical splitting ratio
of 1:32 or 1:64) arranged according to a tree topology. The tree root
is connected to the OLT, while each tree branch may be terminated
20 by a respective ONU (Optical Termination Unit), to which an end user
is connected.

The OLT typically transmits downstream traffic addressed to the
various ONUs in the form of optical signals having a certain
downstream wavelength, while the ONUs typically transmit upstream
25 traffic addressed to the OLT in the form of optical signals having a
certain upstream wavelength different from the downstream
wavelength. The downstream optical signals addressed to the
various ONUs are multiplexed according to the TDM (Time Division
Multiplexing) technique, while the various ONUs access the ODN for
30 transmitting the respective upstream optical signals using a TDMA

(Time Division Multiple Access) technique. Hence, downstream traffic and upstream traffic basically are in the form of a sequence of downstream frames and a sequence of upstream frames, respectively. Each frame is divided in timeslots, and each timeslot carries an optical signal addressed to or transmitted by a certain ONU.

Use of TDM/TDMA allows preventing collisions between optical signals addressed to or transmitted by the various ONUs. In order to enable a proper functioning of TDM/TDMA mechanism, the ONUs of a PON shall be subjected to an activation procedure by the OLT, before they enter their normal operational state.

In particular, the ONU activation procedure as defined by the ITU-T Recommendations G.984.3 (01/2014) sec.10 (for GPON systems) and G.987.3 (01/2014) sec.12 (for XG-PON systems) basically comprises three phases. During a first phase, the ONU under activation recovers the receiving clock from the OLT and synchronizes to the downstream frames. During a second phase, the ONU under activation sends to the OLT a unique identifier (e.g. its serial number) allowing the OLT to uniquely identify the ONU. During a third phase (also termed "ranging phase"), the OLT estimates the round-trip delay between itself and the ONU to be activated. This latter phase allows the OLT calculating an equalization delay to be assigned to the ONU, so as to synchronize it to the other ONUs of the PON. The second and third phases of the activation procedure are performed during a so-called "ranging window", namely a period during which transmission of upstream optical signals from the already active ONUs is temporarily suspended. In order to prevent collisions, the duration T_{ranging} of the ranging window shall be higher than a round-trip delay, which for a typical 20 km ODN is about 200 μs . Hence T_{ranging} is typically longer than the upstream frame period T_{frame} , which is equal to 125 μs for GPON and XG-PON systems.

EP 0 616 443 describes a ranging procedure for PONs wherein the ranging information transmitted by the substations (ONUs) to the main station (OLT) comprise a repetitive ranging-bit-pattern and, facultatively, a preamble-bit-pattern. By using ranging information with a sequence length which is eight bits less than the width of the ranging window, the received ranging information falls within the ranging window if it has a coarse ranging accuracy of ± 4 bits.

Recently, multi-wavelength PONs (including also NG-PON, namely Next Generation PONs) have been proposed, which employ multiple wavelengths for upstream transmission (upstream channels) and multiple wavelengths for downstream transmission (downstream channels). For instance, the so-called NG-PON2 system defined by the ITU-T Recommendation G.989.1 (03/2013) may use several different downstream wavelengths (e.g. up to eight in the range 1596-1603 nm) and several different upstream wavelengths (e.g. up to eight in the range 1524-1544 nm). A multi-wavelength PON basically may be seen as the superimposition of multiple PONs operating at different upstream wavelengths and different downstream wavelengths over a same ODN. In particular, each PON of the multi-wavelength PON has a respective number of ONUs configured to exchange traffic with the OLT using a certain upstream wavelength and a certain downstream wavelength. All the PONs share the unique ODN using a WDM (Wavelength Division Multiplexing) technique.

Since, within each PON of a multi-wavelength PON, the communication between OLT and ONUs is based on the TDM/TDMA technique as described above, a proper activation procedure is required also for the ONUs of the multi-wavelength PON.

However, the activation procedures for PONs described above can not be straightforwardly applied in a multi-wavelength PON context. The ONUs indeed, especially in the NG-PON case, typically

comprise tunable optical transmitters, namely optical transmitters which may be operated to emit on a continuous range or a discrete set of wavelengths. Such optical transmitters are conveniently not wavelength calibrated, meaning that the wavelength at which they start emitting as they are switched on is not predictable in advance
5 with sufficient accuracy. Lack of wavelength calibration is due to the fact that calibration performed in the factory is a quite costly process, whereas the ONUs shall have a reduced cost.

Lack of wavelength calibration however may result in collisions
10 during the activation procedure as described above. For instance, in a NG-PON2 configured with four upstream wavelengths λ_{u1} , λ_{u2} , λ_{u3} , λ_{u4} , the activation procedure of a new ONU on e.g. the upstream channel λ_{u2} requires providing a ranging window during which upstream transmission by all the ONUs already configured on
15 the upstream channel λ_{u2} is suspended, while the new ONU sends to the OLT its identifier. In the meanwhile, upstream transmission by the ONUs activated on the other upstream channels λ_{u1} , λ_{u3} , λ_{u4} continues. Hence, if the ONU under activation (which is still uncalibrated) starts emitting on a wavelength close to any of
20 channels λ_{u1} , λ_{u3} , λ_{u4} (e.g. λ_{u1}) it disadvantageously induces a considerable crosstalk on the upstream traffic on the upstream channel λ_{u1} . This may impair the service quality for some customers and may also cause service interruptions.

US 2013/0259482 describes an ONU registration method for
25 TDM/WDM PONs, including transmitting from an OLT a discovery gate to the ONUs. In response to the discovery gate, an unregistered ONU transmits a register request to another OLT. A discovery window is then provided in the OLT that receives the register request, and this OLT receives the register request in the discovery
30 window. However, also this method is not applicable when the optical transmitters of the ONUs are uncalibrated.

In order to avoid collisions, the ranging windows on the various upstream channels of a multi-wavelength PON may be synchronized. In other words, when a new ONU shall be activated on anyone of the upstream channels, ranging windows are opened simultaneously on all the upstream channels of the multi-wavelength PON, meaning that transmission of upstream traffic is suspended for all the ONUs, independently of their transmission wavelength.

EP 0 585 087 describes a ranging method for use in TDMA systems wherein the OLT continuously superimposes either a low-level, low frequency ranging signal or a low-level, high frequency ranging signal on top of the transmitted data signal that is sent from the OLT to the ONUs.

EP 0 840 963 describes a method and device for coarse ranging in a TDMA PON system, wherein a signal with a low bitrate and with a fractional optical power compared to the main informative flow is counterpropagated compared to the main informative flow.

Summary of the invention

The inventors have noticed that the synchronization of the ranging windows on the various upstream channels for avoiding collisions during the activation procedure, in a multi-wavelength PON, of a new ONU with a tunable, uncalibrated transmitter has some drawbacks.

In particular, this technique is disadvantageous in that it requires a centralized coordination between the various channel terminations which, at the OLT, are responsible of managing the various channels of the multi-wavelength PON. Such a centralized coordination is however not always feasible, because different channel terminations often pertain to different apparatus or different operators, who typically wish to preserve their autonomy and independence from the other operators sharing the same ODN.

In order to circumvent the need to synchronize the ranging

windows on the various upstream channels, in principle out of band techniques could be used, e.g. based on low-level, low frequency signals (briefly, LL-LF signals). In particular, the ONUs might be configured to transmit – at the start of the activation procedure - only
5 activation signals (e.g. the optical signal carrying the ONU identifier) of the LL-LF type, namely with optical power and bitrate much lower than optical power and bitrate of the pre-existing upstream traffic on the ODN transmitted by the already active ONUs. Since the optical power of the LL-LF activation signal is much lower than the optical
10 power of the pre-existing upstream traffic, the LL-LF activation signal substantially does not affect the pre-existing upstream traffic, independently of its wavelength. Hence, no ranging window at all is required, meaning that the LL-LF activation signals may be transmitted continuously without requiring any suspension of the
15 upstream traffic transmission from any ONU of the multi-wavelength PON.

However, the inventors have noticed that the LL-LF activation signal, while being low enough not to impair reception of the pre-existing upstream traffic, has to be suitable for being detected by the
20 receiver at the OLT. These conditions are however not easy to be simultaneously satisfied, as it will be discussed in detail herein after.

As discussed above, when a new ONU with wavelength uncalibrated transmitter is switched on, the LL-LF activation signal transmitted by the new ONU has a not-predictable wavelength.
25 During the activation procedure the new ONU will get however calibrated, namely it is tuned on the desired upstream channel. Assuming for instance that a single ONU is already active on the same upstream channel, the upstream optical signal emitted by this already active ONU is then subject to interferometric crosstalk by the
30 LL-LF activation signal of the new ONU, at least at the end of the activation procedure.

By applying known equations for the calculation of interferometric crosstalk (ITU-T Series G supplement 39 - 09/12, sec. 9.6.3, single interferer case), it may be derived that a penalty of 0.2 dB is obtained when the optical power of the LL-LF activation signal is 41 dB below the optical power of the pre-existing upstream signal (under the assumption of upstream bitrate of 2.5 Gbps, average power decision threshold and extinction ratio of 8.2 dB). Hence, assuming that 0.2 dB is the maximum tolerable penalty on each one of the upstream optical signals transmitted by the already active ONUs, the optical power of the LL-LF activation signal at the OLT shall be at least 41 dB below the sensitivity of the OLT receiver (namely, the minimum optical power detectable by the receiver of the OLT) at the upstream data bitrate, namely the bitrate of upstream signals transmitted by already active ONUs. Taking into account that an ODN typically induces differential losses among different branches of up to 15 dB, that the output power of the ONU's transmitters typically is subject to a tolerance of about 5 dB and that the wavelength of the ONU under activation could be located initially far from the OLT optical receiver channel filter center, in the worst case the optical power of the LL-LF activation signal at the OLT receiver could be down to about 100 dB below the optical power of the pre-existing upstream signals. This makes the detection of the LL-LF activation signal by the OLT's receiver practically unfeasible.

Assuming to apply power levelling and wavelength tuning techniques to the ONU's transmitters, the ideal value of 41 dB may be substantially recovered. However, it shall be noticed that the upstream signals transmitted by the ONU(s) already active on the upstream channel act as a noise on the LL-LF activation signal. Hence, in order to make the LL-LF activation signal detectable, a remarkable reduction of the bitrate of the LL-LF activation signal is needed, which allows to filter out as much as possible the noise

contribution. The inventors have estimated that a maximum bitrate of 0.85 bps is achievable, under the assumption of an upstream bitrate of 2.5 Gbps, an OLT receiver's sensitivity of -26dBm, an energy per bit to noise power spectral density ratio E_b/N_0 of 8.39dB - for BPSK modulation - and bit error rate BER of 10^{-4} . Such a low bitrate, however, disadvantageously makes the activation procedure unacceptably long (it shall be indeed remembered that the LL-LF activation signal carries information which the OLT shall read and process in order to activate the ONU, e.g. the ONU identifier).

10 In summary, the LL-LF technique as known is hardly practically applicable for the purpose of avoiding collisions during the activation, in a multi-wavelength PON, of new ONUs with tunable, uncalibrated transmitters.

15 In view of the above, the inventors have tackled the problem of providing a method for activating an ONU in a multi-wavelength PON which solves that aforesaid drawbacks, namely which does not require reciprocal synchronization of the various upstream channels of the multi-wavelength PON and which is practically feasible.

20 In the present description, the expression "uncalibrated tunable transmitter" will designate an optical transmitter (e.g. a laser) tunable on either a continuous range or a discrete set of wavelengths, which - upon its switching on - starts emitting on a non predictable wavelength amongst those on which it may be tuned.

25 Further, in the present description and in the claims, the expression "activating an ONU on an upstream channel of a multi-wavelength PON" will designate an operation carried out by the OLT which is propaedeutic to normal operation of the ONU, and which comprises recognizing the ONU and - if the ONU's transmitter is an uncalibrated tunable transmitter - tuning the transmission wavelength of its uncalibrated transmitter on a wavelength lying within a predefined upstream channel of those supported by the multi-
30

wavelength PON. The OLT identifies the upstream channel upon which the ONU shall be activated after it recognizes it.

According to a first aspect, the present invention provides a method for activating an optical network unit on an upstream channel of a multi-wavelength passive optical network, the multi-wavelength passive optical network comprising an optical line termination and a number of further optical network units for transmitting upstream signals to the optical line termination on multiple upstream channels including said upstream channel, the method comprising:

- 10 a) during transmission of the upstream signals on the multiple upstream channels, transmitting an activation signal from the optical network unit to the optical line termination, the activation signal having an optical power lower than the optical power of each one of the upstream signals;
- 15 b) during at least one time gap having a time gap duration T_{gap} , suspending transmission of the upstream signals on the upstream channel; and
- c) during the at least one time gap, if the activation signal is transmitted on the upstream channel, detecting the activation
20 signal at the optical line termination.

Preferably, the optical power of the activation signal is at least 28 dB (more preferably, at least 40 dB, even more preferably at least 50 dB) below the sensitivity of the receiver of the optical line termination at the upstream data bitrate. This way, the activation signal induces
25 an acceptable penalty (e.g. of 0.1-1 dB) on each one of the upstream signals transmitted by the further optical network units on the multiple upstream channels.

Preferably, the time gap duration T_{gap} is shorter than $2 \cdot T_{\text{frame}}$, wherein T_{frame} is a frame period of the upstream signals transmitted
30 on the upstream channel. More preferably, the time gap duration T_{gap} is shorter than T_{frame} . Even more preferably, the time gap duration

T_{gap} is shorter than $T_{\text{frame}}/10$.

According to some variants, both activation signal and upstream signals on said upstream channel are received at the optical line termination by a receiver having a bandwidth comprised between
5 75% and 100% the bitrate of said upstream signals transmitted on said multiple upstream channels.

According to such variants, the time gap duration T_{gap} is longer than a minimum value substantially equal to $T_{\text{frame}}/32$, wherein T_{frame} is a frame period of said upstream signals transmitted on said
10 upstream channel. Such minimum value provides a detection performance of the activation signal during the time gap equal to the detection performance with which the same activation signal would be detected by the same receiver if transmission of said upstream signals on said upstream channel were not suspended.

15 According to other advantageous variants, the activation signal is received at the optical line termination by a receiver having a bandwidth comprised between 75% and 100% a bitrate of the activation signal.

According to such advantageous variants, the time gap duration
20 T_{gap} is longer than a minimum value comprised between $T_{\text{frame}}/300000$ and $T_{\text{frame}}/15000$, wherein T_{frame} is a frame period of the upstream signals transmitted on the upstream channel. Such minimum value provides a detection performance of the activation signal during the time gap equal to the detection performance with
25 which the same activation signal would be detected by the same receiver if transmission of said upstream signals on said upstream channel were not suspended.

Preferably, at step a) the activation signal has a bitrate lower than a bitrate of each one of the upstream signals transmitted by the
30 further optical network units on the multiple upstream channels. More preferably, the bitrate of the activation signal is such that a parameter

indicative of the detection performance of the activation signal during the time gap has a minimum predefined value corresponding to a minimum acceptable bit error rate.

Preferably, the bitrate of the activation signal is comprised
5 between 200 bps and 200 kbps (more preferably between 500 bps and 50 kbps, even more preferably between 1 kbps and 5 kbps), and the bitrate of each one of the upstream signals transmitted by the further optical network units is preferably higher than 100 Mbps.

Preferably, the phase of the activation signal is synchronized to a
10 downstream frame transmitted from the optical line termination to the optical network unit.

Preferably, step b) comprises suspending the transmission of the upstream signals on said upstream channel during multiple time gaps.

15 More preferably, the multiple time gaps comprise a single time gap per each upstream frame carrying portions of the upstream signals transmitted on said upstream channel.

Preferably, the inverse of the time lapsing between start of two consecutive time gaps of the multiple gaps is an integer multiple of
20 the bitrate of the activation signal.

Preferably, step c) further comprises sending a feedback signal from the optical line termination to the optical network unit if at step c) the optical line termination detected the activation signal and properly read and processed activation information carried by the activation
25 signal.

Preferably, step a) comprises transmitting the activation signal in a substantially continuous way until a predefined time has expired or until the feedback signal is received at the optical network unit.

30 Preferably, if no feedback signal is received before the predefined time has expired, the optical network unit changes transmission wavelength and transmits again the activation signal.

Preferably, step b) further comprises suspending transmission of the upstream signals also on upstream channels other than the upstream channel. Transmission on the various upstream channels may be suspended in a synchronous or asynchronous way.

5 According to a second aspect, the present invention provides a multi-wavelength passive optical network comprising:

- an optical line termination;
- an optical network unit to be activated on an upstream channel of the multi-wavelength passive optical network; and
- 10 - a number of further optical network units configured to transmit upstream signals to the optical line termination on multiple upstream channels including said upstream channel,

wherein the optical network unit is configured to transmit an activation signal to the optical line termination during transmission of the upstream signals on the multiple upstream channels, the activation signal having an optical power lower than the optical power of each one of the upstream signals; and

15

wherein the optical line termination is configured to, during at least one time gap having a time gap duration T_{gap} , suspend transmission of the upstream signals on the upstream channel and, if the activation signal is transmitted on the upstream channel, detect the activation signal during the at least one time gap.

20

Brief description of the drawings

The present invention will become clearer from the following detailed description, given by way of example and not of limitation, to be read with reference to the accompanying drawings, wherein:

25

- Figure 1 schematically shows an exemplary multi-wavelength PON network suitable for implementing the method for activating an ONU, according to an embodiment of the present invention;
- 30 - Figure 2 is a schematic flow chart of the method for activating an

- ONU, according to an embodiment of the present invention;
- Figure 3 is a time diagram schematically depicting a step of the method according to an embodiment of the present invention;
 - Figure 4 shows time diagrams schematically depicting the method of the invention applied to the multi-wavelength PON of Figure 1;
 - Figure 5 schematically shows a receiver of the OLT suitable for receiving an activation signal according to embodiments of the present invention; and
 - Figure 6 schematically shows a receiver of the OLT suitable for receiving an activation signal according to other embodiments of the present invention.

Detailed description of preferred embodiments of the invention

Figure 1 schematically shows an exemplary multi-wavelength PON (Passive Optical Network) in which the method for activating an ONU, according to embodiments of the present invention, may be applied.

The multi-wavelength PON 1 comprises an OLT 100, a ODN (Optical Distribution Network) 200 and a plurality of ONUs (Optical Network Units) 301-316. The ODN 200 preferably comprises at least one optical splitter and optical fibres arranged according to a tree topology. The root of the ODN 200 is connected to the OLT 100, while each branch of the ODN 200 is preferably terminated by a respective ONU 301-316. More particularly, the ODN 200 shown in Figure 1 comprises (by way of non limiting example) five optical splitters 201, 202, 203, 204, 205 with splitting ratio of 1:4, arranged according to a tree topology with sixteen branches.

The multi-wavelength PON 1 preferably employs multiple downstream wavelengths (or downstream channels) for transmission from the OLT 100 to the ONUs 301-316, and multiple upstream wavelengths (or upstream channels) for transmission from the ONUs

301-316 to the OLT 100. By way of non-limiting example, it is assumed that the multi-wavelength PON 1 uses four downstream wavelengths λ_{d1} , λ_{d2} , λ_{d3} , λ_{d4} in the range 1596-1603 nm and four upstream wavelengths λ_{u1} , λ_{u2} , λ_{u3} , λ_{u4} in the range 1524-1544 nm.

For instance, by way of non limiting example, in the following description it is also assumed that:

- the ONUs 310, 313 are configured to exchange traffic with the OLT using the wavelengths λ_{d1} , λ_{u1} ;
- 10 • the ONUs 304, 305, 306, 308, 316 are configured to exchange traffic with the OLT using the wavelengths λ_{d2} , λ_{u2} ;
- the ONUs 301, 302, 312, 314 are configured to exchange traffic with the OLT using the wavelengths λ_{d3} , λ_{u3} ; and
- 15 • the ONUs 303, 307, 309, 311, 315 are configured to exchange traffic with the OLT using the wavelengths λ_{d4} , λ_{u4} .

Hence, the ONUs 301-316 are basically split into four different groups, each group being configured to exchange user traffic with a respective channel termination of the OLT 100 using a respective upstream wavelength and a respective downstream wavelength.

20 Within each group, the ONUs and the respective channel termination of the OLT 100 exchange user traffic using known TDM/TDMA techniques, while user traffic at different wavelengths (i.e. user traffic addressed to or coming from ONUs of different groups) is multiplexed on the ODN 200 using a known WDM technique. The

25 OLT 100 therefore comprises four different channel terminations (not shown in Figure 1), which may be either autonomous (meaning that each channel termination autonomously manages the respective upstream channel and downstream channel) or under the control of a central manager of the OLT 100 (meaning that a centralized

30 coordination of the various channel terminations - and hence of the management of the various upstream channels and downstream

channels - is provided). According to embodiments not shown in the drawings, the PON 1 may comprise multiple, physically separated OLTs amongst which the various channel terminations are distributed.

5 Herein after, it is assumed that at least one of the ONUs 301-316 of the multi-wavelength PON 1 still has to be activated on its upstream and downstream channels, namely it is connected to the ODN 200 but has not entered its normal operational state yet (namely, it is not exchanging user traffic with the OLT 100 using the
10 intended upstream wavelength and downstream wavelength yet).

 By way of non limiting example, it is assumed that the ONU 316 (indicated by hatching in Figure 1) still has to be activated on the upstream channel λ_{u2} and downstream channel λ_{d2} . Besides, the ONUs 304, 305, 306, 308 are already active on those channels and
15 are accordingly exchanging user traffic with the OLT 100 using the upstream wavelength λ_{u2} and the downstream wavelength λ_{d2} . In particular, with reference to the upstream direction, the ONUs 304, 305, 306, 308 are sending to the OLT 100 respective upstream signals at the upstream wavelength λ_{u2} , using a TDMA (Time
20 Division Multiple Access) technique. Accordingly, the upstream traffic received at the OLT 100 from the ONUs 304, 305, 306, 308 is in the form of a sequence of upstream frames having a frame period T_{frame} . The frame period T_{frame} is of e.g. 125 μs . Within each upstream frame, the ONUs 304, 305, 306, 308 transmit portions of the
25 respective upstream signals within dedicated timeslots.

 It is also assumed that the other ONUs shown in Figure 1 are already active on the respective channels, and are accordingly exchanging user traffic with the OLT 100 using the respective upstream wavelength and downstream wavelength. Similarly to the
30 upstream channel λ_{u2} , also in each one of the upstream channels λ_{u1} , λ_{u3} , λ_{u4} the upstream traffic generated by the relevant ONUs is

in the form of a sequence of upstream frames with frame period T_{frame} . The frame period T_{frame} may be the same for all the upstream channels, or it may be different for each upstream channel. According to other variants not shown in the drawings, the upstream traffic on at least one of the upstream channels has not a framed structure.

With reference now to the flow chart of Figure 2, the method for activating the ONU 316 according to embodiments of the present invention will be described in detail.

10 As the ONU 316 to be activated is connected to the ODN 200, it preferably starts transmitting an activation signal AS to the OLT 100 via the ODN 200 (step 401). Step 401 is optionally preceded by a step during which the ONU 316 under activation recovers the receiving clock from the OLT 100 and synchronizes to the downstream frames (step not shown in Figure 2).

The activation signal AS is preferably a low level, low frequency signal, namely it has optical power P_C and bitrate R_C lower than optical power P_D and bitrate R_D of each one of the upstream signals that the already active ONUs 301-315 are transmitting to the OLT 100.

In particular, the optical power P_C of the activation signal AS is selected so as to induce an acceptable maximum penalty (e.g. of 0.2 dB) on each one of the upstream signals that the already active ONUs 301-315 are transmitting to the OLT 100. More specifically, the optical power P_C of the activation signal AS at the receiver of the OLT 100 is preferably lower than the sensitivity of the receiver of the OLT 100 (namely, the minimum power detectable by the receiver of the OLT 100) at the data upstream bitrate (namely, the bitrate of the upstream signals transmitted by the already active ONUs 301-315).
25
30 Even more specifically, the optical power P_C of the activation signal AS at the receiver of the OLT 100 is preferably 28 dB, more

preferably 40 dB, even more preferably 50 dB below the sensitivity of the receiver of the OLT 100 at the data upstream bitrate. For instance, the optical power P_C of the activation signal AS at the receiver of the OLT 100 may be 41 dB below the sensitivity of the receiver at the OLT 100. Taking into account, as explained above, the differential losses induced by the ODN 200, the tolerance of the output power of the ONU's transmitters and the fact that the wavelength of the ONU 316 under activation could be located initially far from the OLT optical receiver channel filter center, the optical power with which the activation signal AS is transmitted by the ONU 316 is preferably substantially 61 dB below the transmission power of the already active ONUs 301-315, which typically ranges from 5 dBm to 9 dBm, depending on the bitrate R_D and the system class. For instance, if each one of the ONUs 301-315 has a transmission power of 9 dBm, the optical power of the activation signal AS at the ONU 316 is 9 dBm - 61 dB = -52 dBm. This value, as discussed above, provides an acceptable crosstalk penalty of 0.2 dB on each one of the upstream signals, if the bitrate R_D is 2.5 Gbps. In order to provide such a low transmission power (which is well underneath the typical transmission power of the optical transmitter of the ONU 316), an attenuator or a shutter is preferably provided at the output of the optical transmitter. This allows preserving the spectral properties of the optical transmitter, so that the activation signal AS has neither an altered spectrum nor an altered wavelength, hence the subsequent tuning step can properly tune the wavelength of the transmitter of the ONU 316.

Besides, the bitrate R_C of the activation signal AS is selected so as to enable its detection by the OLT 100. Further quantitative considerations in this connection will be provided herein after.

Assuming that the ONU 316 to be activated comprises a tunable, uncalibrated optical transmitter (namely an optical transmitter which

may be operated to emit on a continuous range or a discrete set of wavelengths, the actual wavelength at which it starts emitting as it is switched on being however unpredictable), the wavelength of the activation signal AS may be any one of the wavelengths at which the optical transmitter of the ONU 316 may be tuned. Hence, though the ONU 316 shall be activated on the nominal upstream channel λ_{u2} , at step 401 the wavelength of the activation signal AS is not necessarily λ_{u2} . The tuning of the ONU 316 at the desired upstream wavelength λ_{u2} will be operated subsequently by the OLT 100, as it will be described in detail herein after.

Besides, the phase of the activation signal AS is preferably synchronized to the downstream frames transmitted by the OLT 100 on the downstream channel λ_{d2} on which the ONU 316 shall be activated. This advantageously eases the reception of the activation signal AS at the OLT 100, as it will be discussed in detail herein after.

Besides, the activation signal AS preferably carries activation information which the ONU 316 to be activated shall communicate to the OLT 100. Preferably, the activation signal AS carries a unique identifier of the ONU 316, allowing the OLT 100 to uniquely identify the ONU 316 and to retrieve its activation parameters (e.g. its wavelength tuning parameters). Additionally, the activation signal AS may comprise other activation information, such as for instance status information or control information.

Preferably, the activation signal AS is transmitted by the ONU 316 to the OLT 100 in a substantially continuous way, meaning that it is transmitted substantially with no interruptions. The conditions upon which the ONU 316 stops transmitting the activation signal AS will be described herein after.

While the ONU 316 to be activated is transmitting the activation signal AS in a substantially continuous way, transmission of upstream signals on the upstream channel λ_{u2} (namely, the same

upstream channel on which the ONU 316 shall be activated) is temporarily suspended for a time gap (step 402). The time gap duration T_{gap} is preferably shorter than twice a frame period $2 \cdot T_{\text{frame}}$. More preferably, the time gap duration T_{gap} is shorter than a frame period T_{frame} . Even more preferably the time gap duration T_{gap} is shorter than a frame period $T_{\text{frame}}/10$.

Step 402 is schematically depicted in the time diagram of Figure 3. Figure 3 schematically shows an exemplary upstream frame of the upstream channel $\lambda u2$. The upstream frame is divided into timeslots, and each timeslot is dedicated to the transmission of a portion of an upstream signal US(304), US(305), US(306) and US(308) generated by one of the ONUs 304, 305, 306, 308 already active on the upstream channel $\lambda u2$. As shown in Figure 3 by way of non limiting example, the transmission of the upstream signals is suspended within the frame for a time gap T_{gap} shorter than the frame period T_{frame} . Hence, in this case the suspension only affects a portion of the upstream traffic carried by the upstream frame. If the upstream traffic has not a framed structure (namely, if no T_{frame} is defined), the time gap duration T_{gap} is such that the overall capacity available for the upstream traffic on the upstream channel $\lambda u2$ is reduced by a certain amount, as it will be discussed in detail herein after.

According to advantageous variants, several time gaps are opened at regular time intervals within the sequence of time frames carrying the upstream signals of the ONUs 304, 305, 306, 308 already active on the upstream channel $\lambda u2$. For instance, if $T_{\text{gap}} < T_{\text{frame}}$, one time gap per upstream frame may be opened over a certain number of consecutive upstream frames, or a time gap may be opened every N consecutive upstream frames. Preferably, the time gap is located always at a same position of the frame. For instance, each time gap may be located either at the end of the respective upstream frame (as shown in Figure 3), or at the

beginning of the respective upstream frame. This is however not limiting, since the time gaps may be located at any position of the upstream frames, namely at any intermediate position of the upstream frames. Besides, in case the bitrate R_C of the activation signal AS is lower than the frame rate $1/T_{\text{frame}}$, the time gap rate (namely, the inverse of the time lapsing between start of two consecutive time gaps) is preferably an integer multiple of the bitrate R_C . According to other embodiments, the time gaps may be opened at different positions within the respective upstream frames (e.g. the initial position in a first upstream frame, a first intermediate position in the subsequent upstream frame, an a second intermediate position in the still subsequent upstream frame, and so on). This may be advantageous in order to reduce jitter on data.

In order to suspend transmission from the ONUs 304, 305, 306, 308 already active on the upstream channel λ_{u2} during the time gaps, the OLT 100 (in particular, the channel termination responsible of managing the upstream channel λ_{u2}) preferably omits sending to the ONUs 304, 305, 306, 308 the grants for upstream transmission.

Then, according to embodiments of the present invention, the OLT 100 (and in particular the channel termination responsible of managing the upstream channel λ_{u2}) detects the activation signal AS during the time gaps only (step 403). As mentioned above, the wavelength of the activation signal AS may be anyone of the wavelengths at which the uncalibrated transmitter of the ONU 316 may be tuned. Hence, the wavelength of the activation signal AS may lie in any one of the upstream channels λ_{u1} , λ_{u2} , λ_{u3} , λ_{u4} . The wavelength of the activation signal AS may accordingly lie out of or within the receiver bandwidth of the channel termination responsible of managing the upstream channel λ_{u2} .

In the first case, at step 403 the OLT 100 (in particular its channel termination responsible of managing the upstream channel λ_{u2}) can

not detect the activation signal AS during its time gaps. This case will be dealt with herein after.

In the second case, at step 403 the OLT (in particular its channel termination responsible of managing the upstream channel λ_{u2}) may
5 detect the activation signal AS during its time gaps. In particular, if the time gap rate is an integer multiple of the bitrate R_C of the activation signal AS and if the phase of the activation signal AS is synchronized to the downstream frames received from the OLT 100, the reception of the activation signal AS at the OLT 100 is
10 advantageously eased. First of all, the OLT 100 may easily derive from the downstream frame clock the clock for detecting the activation signal AS. Moreover, the OLT 100 may optionally perform a coarse measurement of the distance of the ONU 316 based on the phase of the received activation signal AS, the phase being
15 dependent on the distance. Besides, the OLT 100 may collect an integer number of samples per bit of the activation signal AS, each sample corresponding to a single time gap period (when the inverse of the bitrate R_C of the activation signal AS is larger than a time gap period T_{gap}). These samples may accordingly be optimally integrated
20 and contribute to optimize the detection performance of the OLT 100. In case the time gap rate is not an integer multiple of the bitrate R_C and/or the phase of the activation signal AS is not synchronized to the downstream frame period, the OLT 100 may nonetheless detect the activation signal AS. However, recovering the clock needed to
25 correctly sample the activation signal AS is more difficult. Moreover, sampling jitter may arise.

In any case, since during the time gaps transmission of upstream signals from the ONUs 304, 305, 306, 308 already active of the upstream channel λ_{u2} is suspended, the detection of the activation
30 signal AS is remarkably improved, as it will be discussed in detail herein after.

Then, if at step 403 the OLT 100 (namely its channel termination responsible of managing the upstream channel λ_{u2}) was able to detect the activation signal AS during its time gaps and to properly read and process the activation information carried by the activation signal AS, it preferably sends a feedback signal to the ONU 316 to be activated (step not shown in the drawings).

The ONU 316 to be activated, on the other hand, is preferably configured to transmit the activation signal AS for a predefined period of time. If, upon expiration of such period of time, the ONU 316 does not receive any feedback signal from the channel termination which is responsible of managing the upstream channel λ_{u2} at the OLT 100 (step 404), it determines that it is trying to activate on the wrong upstream channel (namely, the wavelength of the activation signal AS was lying in one of the upstream channels λ_{u1} , λ_{u3} , λ_{u4} , in-between two upstream channels or even outside the upstream wavelength range). Hence, the ONU 316 preferably changes its transmission wavelength (step 405) and tries to activate on a new wavelength. Steps 401, 402, 403, 404 and 405 are accordingly iterated, until the ONU 316 receives a feedback signal from the channel termination responsible of managing the upstream channel λ_{u2} at the OLT 100, meaning that the ONU 316 transmission wavelength now lies within the receiver bandwidth of the channel termination responsible of managing the upstream channel λ_{u2} at the OLT 100.

When the ONU 316 receives the feedback signal from the OLT 100, the ONU 316 is under the control of the OLT 100 (in particular, of the channel termination responsible of managing the upstream channel λ_{u2}), which preferably completes the activation of the ONU 316 (step 406). In particular, the OLT 100 preferably optimizes the wavelength tuning of the ONU 316 by sending it suitable wavelength tuning commands. At step 406, the OLT 100 may also calculate the

distance of the ONU 316, e.g. by using the phase of the activation signal AS as mentioned above. Alternatively, the OLT 100 may carry out a known ranging procedure, by opening a ranging window on the upstream channel λ_{u2} on which the ONU 316 is being activated. It shall be noticed that, since the transmitter of the ONU 316 is now calibrated on the upstream wavelength λ_{u2} , there is no longer a risk of collisions with upstream signals generated by the ONUs already active on the other upstream channels λ_{u1} , λ_{u3} and λ_{u4} , even if the ranging windows on the various upstream channels are not synchronized and even if no ranging window is opened at all on the other channels.

Therefore, the method for activating an ONU according to embodiments of the present invention exhibits several advantages.

The method described above indeed solves the problem of collisions which might arise during the activation of an ONU with a non-calibrated tunable transmitter by using a low level, low frequency activation signal combined with time gaps for the detection of the activation signal.

Though the activation signal is a low level signal (and then it may be hardly detectable), use of time gaps greatly improves its detection conditions at the OLT (as it will be discussed in detail herein after), thereby allowing to increase the bitrate of the activation signal to such an extent that makes this technique practically feasible, especially if an optimized receiver is adopted.

On the other hand, no synchronization of the time gaps between the various upstream channels is required, because the activation signal is a low level signal, and accordingly it may be substantially continuously superimposed to pre-existing upstream signals substantially without impairing their reception.

This means that the OLT 100 may advantageously open time gaps on each upstream channel λ_{u1} , λ_{u2} , λ_{u3} , λ_{u4} independently, as

schematically depicted in Figure 4. In particular, Figure 4 shows exemplary time gaps opened on the upstream channels λ_{u1} , λ_{u2} , λ_{u3} , λ_{u4} by the OLT 100, in particular by the channel terminations responsible of managing the upstream channels λ_{u1} , λ_{u2} , λ_{u3} , λ_{u4} at the OLT 100. Figure 4 shows that the four channel terminations of the OLT 100 open time gaps within the respective upstream channels in an asynchronous way, since each channel termination autonomously decides when time gaps shall be opened on its upstream channel independently of the other channel terminations, and tries to autonomously detect possible activation signal(s) during the time gaps opened on its respective upstream channel. Since no reciprocal synchronization of the time gaps is required between the upstream channels λ_{u1} , λ_{u2} , λ_{u3} , λ_{u4} , more generally no reciprocal synchronization of the upstream frames in the various upstream channels is required. This is also apparent in Figure 4, where the start times of the upstream frames in the various upstream channel are clearly not aligned. Hence, autonomy of each channel termination in managing the respective channels is advantageously fully preserved.

Furthermore, each channel termination may also advantageously determine the time gap duration of the respective time gaps in an autonomous way. For instance, while a channel termination may decide to open a single long time gap (namely, with $T_{\text{gap}} > T_{\text{frame}}$) for activating new ONUs, another channel termination of the same OLT may decide to open multiple short time gaps (namely, with $T_{\text{gap}} < T_{\text{frame}}$) for activating new ONUs. In Figure 4, by way of example, all the channel terminations of the OLT 100 open multiple time gaps with $T_{\text{gap}} < T_{\text{frame}}$, all the time gaps having substantially a same duration. As discussed above, this is however non limiting.

Hence - if the various channels pertain to different apparatuses/operators sharing the same ODN 200 - the various

operators may advantageously preserve their autonomy and a certain flexibility in choosing time gap duration, and number and positions of the time gaps. Each operator may accordingly autonomously decide when time gap(s) shall be opened on its own
5 upstream channel for activation purposes. For instance, an operator may decide to systematically open time gaps on its own upstream channel in a periodic way, in order to periodically check whether a new ONU shall be activated. Another operator of the same multi-wavelength PON, besides, may decide to open time gaps only when
10 a new ONU is expected to activate on its upstream channel.

Furthermore, though opening time gaps on the upstream channels other than λ_{u2} (namely, the one on which the ONU 316 shall be activated) is not needed for allowing detection of the activation signal AS, nonetheless according to some variants of the present invention
15 the channel terminations of the OLT 100 may open time gaps (either in a synchronous or asynchronous way) on all the upstream channels λ_{u1} , λ_{u2} , λ_{u3} , λ_{u4} during transmission of the activation signal AS. This allows shortening the activation time of the new ONU 316. Indeed, since the wavelength of the activation signal AS may fall
20 within the receiver bandwidth of anyone of the channel terminations of the OLT 100 (which is however not known a priori), opening time gaps on all the upstream channels allows such channel termination detecting the activation signal AS as the ONU 316 starts transmitting it. In other words, whichever is the transmission wavelength of ONU
25 316 as it is switched on, one of the channel terminations of the OLT 100 is capable of detecting the activation signal AS at that wavelength. Hence, the OLT 100 may detect the activation signal AS as the ONU 316 starts transmitting it, independently of its wavelength, via one of its channel terminations. In other words, with
30 reference again to the flow chart of Figure 2, the OLT 100 is able to detect the activation signal AS at the first iteration of step 403,

without the need of performing any iteration of step 405 (the ONU 316 changes wavelength). Only in case the activation signal AS lies in-between two upstream channels, or outside the OLT receivers wavelength band, iterations of step 405 will be necessary.

5 It shall be noticed that, differently from the known ranging procedure, synchronization of the time gaps on the various upstream channels according to such variants of the invention is not needed. The implementation of such variants of the invention requires anyway a central coordination between the channel terminations of the OLT
10 100, which is not always possible or desirable.

As mentioned above, detection of the activation signal AS during the time gaps advantageously improves the detection condition of the activation signal AS at the OLT compared to the known LL-LF technique where detection is done in the presence of upstream data
15 traffic.

More particularly, as discussed above with reference to the known implementation of the LL-LF technique (no time gaps), a penalty associated with interferometric crosstalk of 0.2 dB is obtained on the reception of an upstream signal from an already active ONU, when
20 the optical power of the activation signal is 41 dB below the sensitivity of the receiver at the OLT at the upstream data bitrate. Besides, in order to enable the OLT to detect the activation signal, the noise induced by the upstream signal on the activation signal shall be minimized. Since the power of such noise is much greater
25 than the power of the activation signal itself, very low bitrates (<1 bps in a typical scenario) shall be used in order to effectively filter out the noise contribution, which make the activation procedure as known unacceptably long.

Conversely, the inventors have estimated that detecting the activation signal AS during the time gaps remarkably relieves the
30 noise impact on the activation signal AS during its detection, thereby

allowing to increase the bitrate of the activation signal AS to acceptable values.

More particularly, the performance of detection of the activation signal AS at the OLT 100 during the time gaps is determined by:

- 5 • the optical power P_C of the activation signal AS (that, as discussed above, is limited by the maximum crosstalk penalty acceptable on the upstream signals transmitted by the already active ONUs);
- the time gap duration T_{gap} (generally speaking, the higher the time gap duration T_{gap} , the higher the energy per bit of the activation signal AS that can be collected in the time gaps); and
- 10 • the amount of noise N_0 at the receiver of the OLT 100 (which basically is the intrinsic receiver noise contribution, since all the other ONUs 301-315 of the multi-wavelength PON 1 are either silent during the time gaps or operating on a different upstream channel).

15 Depending on the ratio between the bitrate R_C of the activation signal AS and the time gap duration T_{gap} , a single time gap may allow detection of several bits carried by the activation signal AS (which happens if the bitrate of the activation signal AS is relatively high, e.g. if $R_C \gg 1/T_{frame}$ and $T_{gap} < T_{frame}$), or detection of a single bit is spread over a number of consecutive time gaps (which happens if the bitrate of the activation signal AS is relatively low, e.g. $R_C \ll 1/T_{frame}$ and $T_{gap} < T_{frame}$). In both cases, the energy per bit $E_{b,C}$ of the activation signal AS within time gaps is given by the following

20 equation:

25

$$E_{b,C} = \frac{1}{M_g} \cdot \frac{m^2 \cdot \bar{P}_C^2}{2R_C}, \quad [1]$$

where $M_g = T_{frame}/T_{gap}$, m is the modulation index (assuming for example that the activation signal AS is a modulated subcarrier, e.g. BPSK), P_C is the average optical power of the control signal AS and

R_C is the bitrate of the control signal AS.

In order to estimate the noise power spectral density N_0 at the receiver of the OLT 100, it is firstly assumed that the OLT 100 (in particular, the channel termination responsible of managing the upstream channel λ_{u2}) comprises a single receiver for detecting both the activation signal AS and the upstream signals generated by the ONUs already active on the channel λ_{u2} . The receiver of the channel termination responsible of managing the upstream channel λ_{u2} at the OLT 100 has the structure schematically depicted in Figure 5.

5 The receiver 500 comprises a photodiode 501 and a trans-impedance amplifier 502 connected at the output of the photodiode 501. The receiver 500 also comprises a clock and data recovery unit 503 connected to the output of the trans-impedance amplifier 502, which is configured to recover clock and user data from the upstream signals transmitted from the ONUs 304, 305, 306, 308 already active on the upstream channel λ_{u2} . The receiver 500 also preferably comprises a band-pass filter 504, also connected at the output of the same trans-impedance amplifier 502. The band-pass filter 504 is preferably centered substantially around the subcarrier of the activation signal AS, so as to filter out the intrinsic noise of the trans-impedance amplifier. It has to be noted indeed that this trans-impedance amplifier 502, being used for reception of both the activation signal AS and the upstream signals generated by the ONUs already active on the channel λ_{u2} , has a large bandwidth, and therefore also a relatively high noise. In particular, the bandwidth is typically about 75% of the bitrate R_D of the upstream signals carrying user data. For instance, if the bitrate R_D is 2.5 Gbps, the receiver bandwidth is about 1.9 GHz. The receiver 500 also preferably comprises a digital signal processing unit 505 connected at the output of the band-pass filter 504. The digital signal processing unit 505 is configured to recover the activation information carried by the

10

15

20

25

30

activation signal AS.

Therefore, in the receiver 500 of Figure 5, the photodiode 501 and the trans-impedance amplifier 502 normally used for detection of the upstream signals transmitted from the ONUs 304, 305, 306, 308 already active on the upstream channel λ_{u2} are also used for detection of the activation signal AS transmitted by the ONU 316 to be activated on the upstream channel λ_{u2} . This means that, in the following estimation of the noise power spectral density N_0 , it is assumed that at least part of the receiver 500 is not specifically optimized for the reception of the activation signal AS. The results provided by such estimation are accordingly pejorative, and may be improved by assuming to use a dedicated receiver for the activation signal AS, as it will be discussed in detail herein after.

In the receiver 500 of Figure 5, the noise power spectral density N_0 may then be estimated as the optical power that makes the minimum-power upstream signal be received at a typical pre-FEC BER= 10^{-4} , namely (when the photodiode 501 is a PIN photodiode):

$$N_0 \cong \frac{\overline{P}_D^2}{16 \cdot R_D}, \quad [2]$$

where P_D is the average power of the minimum-power upstream signal corresponding to the reference BER= 10^{-4} (i.e. the receiver sensitivity), while R_D is the bitrate of the upstream signal. Equation [2] has been obtained under the assumption that the noise power spectral density N_0 is flat over the whole receiver spectrum and assuming an upstream signal with infinite extinction ratio.

Hence, combining equation [1] and equation [2], the performance of the detection of the activation signal AS during a time gap, expressed in terms of energy per bit to noise power spectral density ratio, is provided by the following equation (when a PIN photodiode is used):

$$\left(\frac{E_b}{N0}\right)_C \text{ timegap} = \left(\frac{\bar{P}_C}{\bar{P}_D}\right)^2 \frac{R_D}{R_C} \cdot \frac{8m^2}{M_g} \quad [3]$$

From equation [3], it is apparent that the detection performance improves as the average power of the control signal P_C increases, the bitrate R_C of the control signal decreases, and the ratio M_g decreases (namely, as the time gap duration T_{gap} increases).

The inventors have then compared the performance of detection of the activation signal AS during the time gaps with the performance of detection if no time gap were provided (namely, if during detection of the activation signal AS the transmission from the ONUs already active on the same upstream channel λ_{u2} were not suspended). The energy per bit to noise power spectral density ratio for such case is provided by the following equation:

$$\left(\frac{E_b}{N0}\right)_C \text{ no-timegap} = \left(\frac{\bar{P}_C}{\bar{P}_D}\right)^2 \frac{R_D}{R_C} \cdot \frac{m^2}{4} \quad [4]$$

By comparing equation [3] with equation [4], it follows:

$$\left(\frac{E_b}{N0}\right)_C \text{ timegap} = \left(\frac{E_b}{N0}\right)_C \text{ no-timegap} \cdot \frac{32}{M_g} \quad [5]$$

Hence, under the above conservative assumptions on the receiver structure (non optimized receiver), it may be noticed that provision of dedicated time gaps for the detection of the activation signal AS entails an improvement of the detection performance - over the case with no time gap - when the ratio M_g is lower than 32. Hence, all other conditions (namely, bit rates R_C , R_D , powers P_C , P_D and modulation format) being equal, an improvement is obtained when the time gap duration T_{gap} is at least $T_{\text{frame}}/32 \cong 3\% T_{\text{frame}}$. This means that if $T_{\text{frame}} = 125 \mu\text{s}$, a time gap duration T_{gap} of at least $3.9 \mu\text{s}$ provides detection performance equal to or better than the known case with no time gap, all the other conditions (namely, bit rates R_C ,

R_D , powers P_C , P_D and modulation format) being equal.

An example is provided herein after. Assuming $R_D=2.5$ Gbps, a receiver sensitivity of -26 dBm to -32.5 dBm and an ONU transmission power of 5 dBm to 9 dBm, in order to guarantee a penalty of 0.2 dB to 1 dB on the upstream signals, the optical power P_C of the activation signal AS, at the OLT receiver, shall be comprised between -73.5 dBm and -54 dBm. Assuming $T_{\text{frame}} = 125\mu\text{s}$, $m = 0.9$ (which is a typical value for BPSK modulation) and $T_{\text{gap}} = 3.9 \mu\text{s}$ (which, as discussed above, is the time gap duration providing detection performance equal to the known case with no time gap), an energy per bit to noise power spectral density ratio equal to 8.39 dB (which is the value required for providing a pre-FEC BER of 10^{-4} in case of BPSK modulation) is achieved when the bitrate R_C of the activation signal AS is about 0.5 bps or 184 bps respectively for a penalty of 0.2dB or 1dB. This, as discussed above, are however too low bitrates for the activation signal AS, since they leads to unacceptably long activation times.

Besides, by providing a time gap duration T_{gap} K times the minimum value $T_{\text{frame}}/32$ (e.g. $K=10$ times), also the bitrate R_C of the activation signal AS may be multiplied by K, while preserving the same detection performance (namely, the same value 8.39 dB of the energy per bit to noise power spectral density ratio). Hence, advantageously, detection of the activation signal AS during time gaps allows increasing the bitrate R_C of the activation signal AS, thereby shortening the activation time in comparison to the known case with no time gaps. The time gap duration T_{gap} however may not be increased indefinitely, its preferred maximum value being $2T_{\text{frame}}$, as discussed above. The maximum achievable bitrate R_C is accordingly limited too. It shall also be noticed that, according to equation [4], the bitrate R_C of the activation signal AS increases as the bitrate R_D increases. In general, the bitrate R_C of the activation

signal AS is preferably comprised between $R_D \cdot 10^{-7}$ and $R_D \cdot 10^{-5}$, e. g. $R_D \cdot 10^{-6}$.

The inventors have however noticed that, since the activation signal AS is detected during the time gaps, a further improvement of the detection performance (and therefore the possibility to further increase the bitrate R_C of the activation signal AS) may be achieved by detecting the activation signal AS with an optimized receiver, namely a receiver dedicated exclusively to reception of the activation signal AS (the upstream signals carrying user traffic being instead received by a separate, dedicated receiver).

It is indeed noticed that, while the detection performance in the known case (no time gap) is mainly limited by the average power of the upstream signals transmitted by the already active ONUs within the bandwidth of the activation signal AS (which can not be further reduced by optimizing the receiver), the detection performance in the time gap case is mainly limited by the intrinsic noise of the receiver, because there is no power of the upstream signals transmitted by the already active ONUs during the time gaps. Hence, by suitably optimizing the receiver, an improvement of the detection performance in the time gap case may be obtained.

As schematically depicted in Figure 6, the optimized receiver 600 preferably comprises a photodiode 601 and a filter 602 suitable for separating activation signal AS and upstream signals. The receiver 600 also comprises a first trans-impedance amplifier 603 suitable for amplifying the upstream signals transmitted from the ONUs 304, 305, 306, 308 already active on the upstream channel λ_{u2} , and a clock and data recovery unit 604 connected to the output of the trans-impedance amplifier 603, which is configured to recover clock and user data from the upstream signals transmitted from the ONUs 304, 305, 306, 308 already active on the upstream channel λ_{u2} . Besides, the receiver 600 also comprises a second trans-impedance amplifier

605 with a filter 606 and a digital signal processing unit 607 configured to recover the activation information carried by the activation signal AS. The bandwidth of the trans-impedance amplifier 605-filter 606 is much narrower than the bandwidth of the first trans-impedance amplifier 603. In particular, the bandwidth of the trans-impedance amplifier 605-filter 606 comprised in the optimized receiver 600 is preferably comprised between 75% and 100% the bitrate R_C of the activation signal AS. For instance, if the bitrate R_C of the activation signal AS is 1 kbps (which is a bitrate achievable using an optimized receiver, as it will be discussed in detail herein after), the bandwidth of the trans-impedance amplifier 605-filter 606 may be about 1 kHz.

The receiver 600 shown in Figure 6 - though it has two separate branches dedicated to reception of the activation signal AS and of the upstream signals from the ONUs already active on the upstream channel λ_{u2} , respectively - advantageously comprises a single photodiode. According to other embodiments not shown in the drawings, the receiver may comprise two separate photodiodes for the detection of the activation signal AS and of the upstream signals from the ONUs already active on the upstream channel λ_{u2} , respectively.

The optimized receiver 600, whose branch dedicated to reception of the activation signal AS has a bandwidth narrower than the receiver 500, also has a noise power spectral density lower than that estimated with equation [2]. For instance, typical noise power spectral density values for non optimized receivers are $1.6 \cdot 10^{-22}$ A^2/Hz for a bandwidth of 10 Gbps, $4 \cdot 10^{-24}$ A^2/Hz for a bandwidth of 2.5 Gbps, and $3.2 \cdot 10^{-24}$ A^2/Hz for a bandwidth of 622 Mbps. On the other hand, an optimized receiver, whose bandwidth is tailored on the bitrate R_C of the activation signal as described above, typically exhibits noise power spectral densities of 10^{-25} A^2/Hz - 10^{-26} A^2/Hz .

Hence, in comparison to values provided by equation [2], by using an optimized receiver the noise power spectral density is reduced by at least 2 or 3 orders of magnitude.

This corresponds to an improvement of the detection performance (namely, to an increase of the energy per bit to noise power spectral density ratio) by 20 or 30 dB, in comparison to the case of detection during time gaps using a non optimized receiver, all the other conditions (namely, time gap duration T_{gap} , bit rates R_C , R_D , powers P_C , P_D and modulation format) being equal.

This improvement of the detection conditions provided by the optimized receiver may be exploited e.g. for reducing the time gap duration T_{gap} (which is desirable if one wishes to reduce the upstream bandwidth consumption for activation purposes) and/or for increasing the bitrate R_C of the activation signal AS (which is instead desirable if one wishes to reduce the activation time).

Assuming that only the reduction of the upstream bandwidth consumption is pursued, the minimum time gap duration T_{gap} which provides the same detection performance as the known case with no time gaps may be reduced by at least 2 or 3 orders of magnitude relative to its value $T_{\text{frame}}/32$ (valid for the case of non optimized receiver, as discussed above). Hence, with an optimized receiver, a time gap duration T_{gap} of at least 0.003% - 0.03% (corresponding to 4 - 40 nanoseconds, if $T_{\text{frame}} = 125 \mu\text{s}$) provides detection performance equal to or better than the known case with no time gap, all the other conditions (namely, bit rates R_C , R_D , powers P_C , P_D and modulation format) being equal.

On the other hand, assuming that only the reduction of the activation time is pursued, keeping a time gap duration T_{gap} higher than $T_{\text{frame}}/32$ allows multiplying the bitrate R_C of the activation signal AS by 2 or 3 orders of magnitude relative to its value providing acceptable detection performance with a non optimized receiver.

Hence, the bitrate R_C of the activation signal may be increased to hundreds or even thousands of bits per second, while keeping an acceptable penalty of about 0.2 dB on the upstream signals generated by the already active ONUs. For instance, with an
5 acceptable penalty of 0.2 dB on the data channel, with $T_{\text{gap}} = 18\mu\text{s}$ and an optimized receiver, a bitrate R_C of the activation signal AS equal to 1kbit/s can be reached.

In general, the advantage provided by use of an optimized receiver may be used in part for reducing the time gap duration T_{gap}
10 relative to its minimum value obtained when a non optimized receiver is used, and in part for increasing the bitrate R_C of the activation signal AS relative to its maximum value achievable when a non optimized receiver is used. In particular, the bitrate R_C is increased to a value preferably comprised between 200 bps and 200 kbps, more
15 preferably between 500 bps and 50 kbps, even more preferably between 1 kbps and 5 kbps.

With such high bitrates, the activation time of the new ONU 316 is greatly reduced, since the activation information carried by the activation signal AS are received and detected by the receiver of the
20 OLT 100 in a quite short time, e.g. less than one minute taking also into account the need for multiple trials (namely, multiple iterations of step 405 shown in Figure 2) to tune onto the expected upstream channel and also the event of collisions generated by other ONUs trying to activate at the same time on the same wavelength. For
25 example, transmission of a 32 byte serial number of the ONU 316 may require up to about 1 second. Even if transmission of the serial number must repeated several times (because the ONU 316 is not transmitting on the expected upstream channel, or because it collides with other ONUs attempting activation), the complete activation
30 procedure may be completed in up to the order of a minute, in the worst case.

The increase of the bitrate R_C also allows increasing the amount of activation information carried by the activation signal AS. For instance, besides carrying the identifier of the ONU 316, the control signal may also carry status information or control information from the ONU 316 to the OLT 100.

It shall be noticed that, though the above calculations for both non optimized receiver and optimized receiver are based on the assumption that the upstream traffic has a framed structure with frame period T_{frame} , similar calculations may be made also for other embodiments where the upstream traffic transmitted by the already active ONUs has not a periodic framed structure (namely, wherein no frame period T_{frame} may be defined). In such cases, the preferred values and ranges for T_{gap} may be expressed (instead of in term of T_{gap}/T_{frame}) in terms of percentage of the overall capacity originally available on the upstream channel $\lambda u2$ which is taken away from transmission by the ONUs already active of the upstream channel $\lambda u2$ and which is dedicated to reception of the activation signal AS.

The method according to embodiments of the present invention, therefore, advantageously solves the problem of collisions which might arise during the activation of an ONU with a non-calibrated tunable transmitter by using a low level, low frequency activation signal combined with time gaps for the detection of the activation signal. Though the activation signal is a low level signal, use of time gaps greatly improves its detection conditions at the OLT, thereby allowing to increase the bitrate of the activation signal to such an extent that makes this technique practically feasible. Moreover, the method described allows fully exploiting the advantage of using a narrow-bandwidth (and hence low-noise) dedicated trans-impedance amplifier to detect the LL-LF activation signal because, thanks to detection during the time gaps, the detection performance is not limited by the noise caused by the presence of other active ONUs on

the same upstream channel (as is the case for known LL-LF techniques), but by the intrinsic noise of the dedicated trans-impedance amplifier. On the other hand, no synchronization of the time gaps between the various upstream channels is required, because the activation signal is a low level signal, and accordingly it may be superimposed to pre-existing upstream signals substantially without impairing their reception.

CLAIMS

1. A method for activating an optical network unit (316) on an upstream channel (λ_{u2}) of a multi-wavelength passive optical network (1), said multi-wavelength passive optical network (1) comprising an optical line termination (100) and a number of further optical network units (301-315) for transmitting upstream signals to said optical line termination (100) on multiple upstream channels (λ_{u1} , λ_{u2} , λ_{u3} , λ_{u4}) including said upstream channel (λ_{u2}), said method comprising:
 - a) during transmission of said upstream signals on said multiple upstream channels (λ_{u1} , λ_{u2} , λ_{u3} , λ_{u4}), transmitting an activation signal (AS) from said optical network unit (316) to said optical line termination (100), said activation signal (AS) having an optical power (P_C) lower than the optical power of each one of said upstream signals;
 - b) during at least one time gap having a time gap duration T_{gap} , suspending transmission of said upstream signals on said upstream channel (λ_{u2}); and
 - c) during said at least one time gap, if said activation signal (AS) is transmitted on said upstream channel (λ_{u2}), detecting said activation signal (AS) at said optical line termination (100).
2. The method according to claim 1, wherein said optical power (P_C) is at least 28 dB below a sensitivity of a receiver by which said optical line termination (100) receives said upstream signals transmitted to said optical line termination (100) on said multiple upstream channels (λ_{u1} , λ_{u2} , λ_{u3} , λ_{u4}).
3. The method according to any of the preceding claims, wherein said time gap duration T_{gap} is shorter than $2 \cdot T_{frame}$, wherein T_{frame} is a frame period of said upstream signals transmitted on said

upstream channel (λ_{u2}).

4. The method according to any of the preceding claims, wherein said activation signal (AS) is received at said optical line termination (100) by a receiver having a bandwidth comprised between 75% and 100% a bitrate (R_C) of said activation signal (AS).
5
5. The method according to claim 4, wherein said time gap duration T_{gap} is longer than a minimum value comprised between $T_{frame}/300000$ and $T_{frame}/15000$, wherein T_{frame} is a frame period of said upstream signals transmitted on said upstream channel (λ_{u2}).
10
6. The method according to any of the preceding claims, wherein at said step a) said activation signal (AS) has a bitrate (R_C) lower than a bitrate (R_D) of each one of said upstream signals transmitted by said further optical network units (301-315) on said multiple upstream channels (λ_{u1} , λ_{u2} , λ_{u3} , λ_{u4}).
15
7. The method according to claim 6, wherein said bitrate (R_C) of said activation signal (AS) is comprised between 200 bps and 200 kbps and said bitrate (R_D) of each one of said upstream signals transmitted by said further optical network units (301-315) is higher than 100 Mbps.
20
8. The method according to any of the preceding claims, wherein said step b) comprises suspending said transmission of said upstream signals on said upstream channel (λ_{u2}) during multiple time gaps.
25
9. The method according to claim 8, wherein said multiple time gaps comprise a single time gap per each upstream frame carrying portions of said upstream signals transmitted on said upstream channel (λ_{u2}).

10. The method according to claim 9, wherein the inverse of a time lapsing between start of two consecutive time gaps of said multiple gaps is an integer multiple of a bitrate (R_C) of said activation signal (AS).
- 5 11. The method according to any of the preceding claims, wherein step c) further comprises sending a feedback signal from said optical line termination (100) to said optical network unit (316) if at said step c) said optical line termination (100) detected said activation signal (AS) and properly read and processed activation
10 information carried by said activation signal (AS).
12. The method according to claim 11, wherein said step a) comprises transmitting said activation signal (AS) in a substantially continuous way until a predefined time has expired or until said feedback signal is received at said optical network
15 unit (316).
13. The method according to claim 12 wherein, if no feedback signal is received before said predefined time has expired, said optical network unit (316) changes transmission wavelength and transmits again said activation signal (AS).
- 20 14. The method according to any of claims 1 to 12, wherein said step b) further comprises suspending transmission of said upstream signals also on upstream channels (λ_{u1} , λ_{u3} , λ_{u4}) other than said upstream channel (λ_{u2}).
- 25 15. A multi-wavelength passive optical network (1) comprising:
 - an optical line termination (100);
 - an optical network unit (316) to be activated on an upstream channel (λ_{u2}) of said multi-wavelength passive optical network (1); and
 - a number of further optical network units (301-315)

configured to transmit upstream signals to said optical line termination (100) on multiple upstream channels (λ_{u1} , λ_{u2} , λ_{u3} , λ_{u4}) including said upstream channel (λ_{u2}),

5 wherein said optical network unit (316) is configured to transmit an activation signal (AS) to said optical line termination (100) during transmission of said upstream signals on said multiple upstream channels (λ_{u1} , λ_{u2} , λ_{u3} , λ_{u4}), said activation signal (AS) having an optical power (P_C) lower than the optical power of each one of said upstream signals; and

10 wherein said optical line termination (100) is configured to, during at least one time gap having a time gap duration T_{gap} , suspend transmission of said upstream signals on said upstream channel (λ_{u2}) and, if said activation signal (AS) is transmitted on said upstream channel (λ_{u2}), detect said activation signal (AS)
15 during said at least one time gap.

ABSTRACT

It is disclosed a method for activating an ONU in a multi-wavelength PON. Other ONUs may be already active and transmit upstream signals to the OLT on various upstream channels. The new ONU
5 transmits an activation signal superimposed to such upstream signals. Since the ONU may comprise an uncalibrated tunable transmitter, initially the activation signal wavelength might be different from that upon which the ONU shall be activated. The activation signal optical power is lower than the other upstream signals, so as
10 not to impair their reception at the OLT. The OLT operates the ONUs already active on the upstream channel on which the new ONU shall be activated to suspend transmission for one or more time gaps, during which the OLT detects the activation signal. This improves the activation signal detection conditions, thereby allowing to increase its
15 bitrate. An acceptable duration of the activation procedure is then achieved.

(Fig. 3)

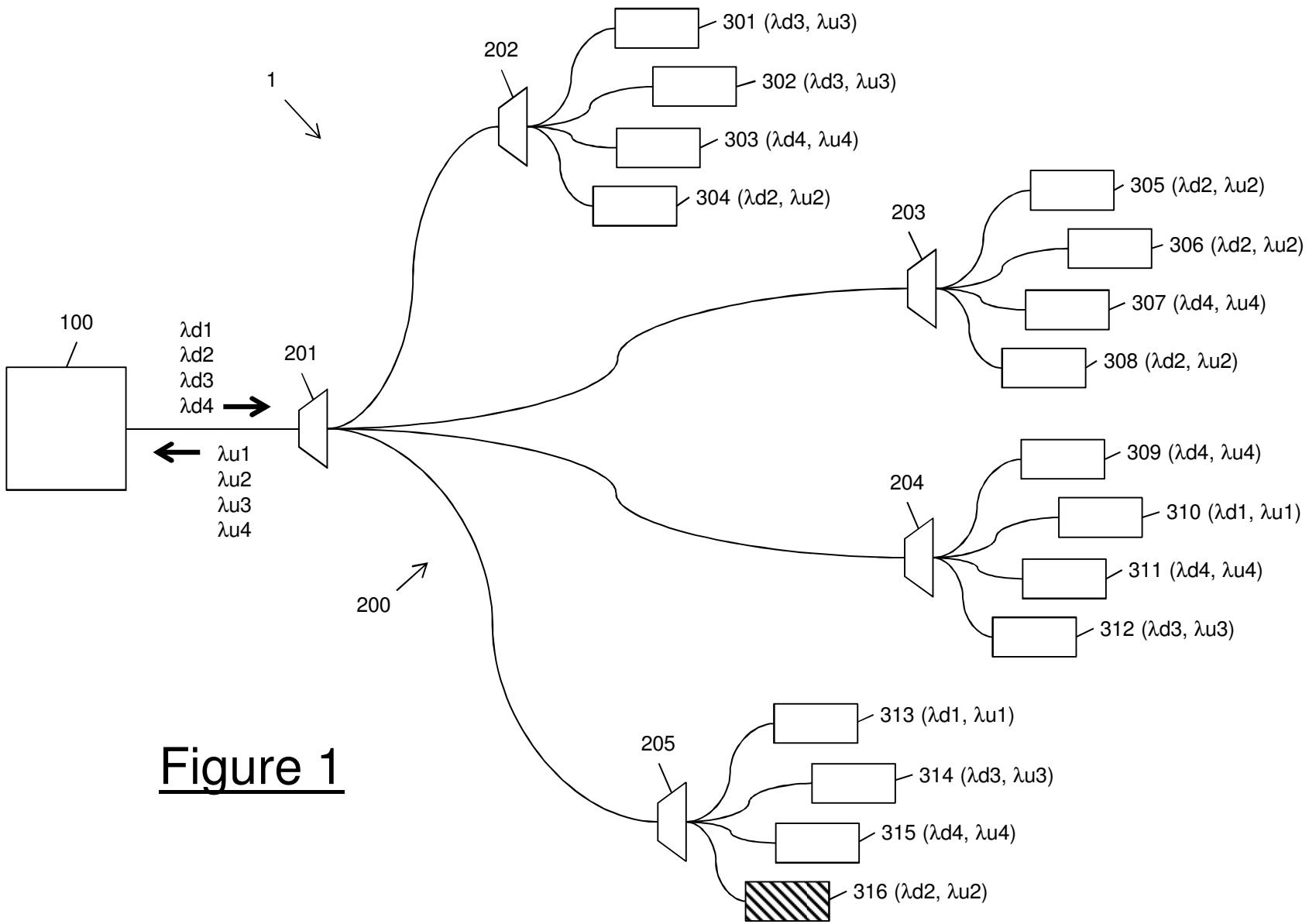

Figure 1

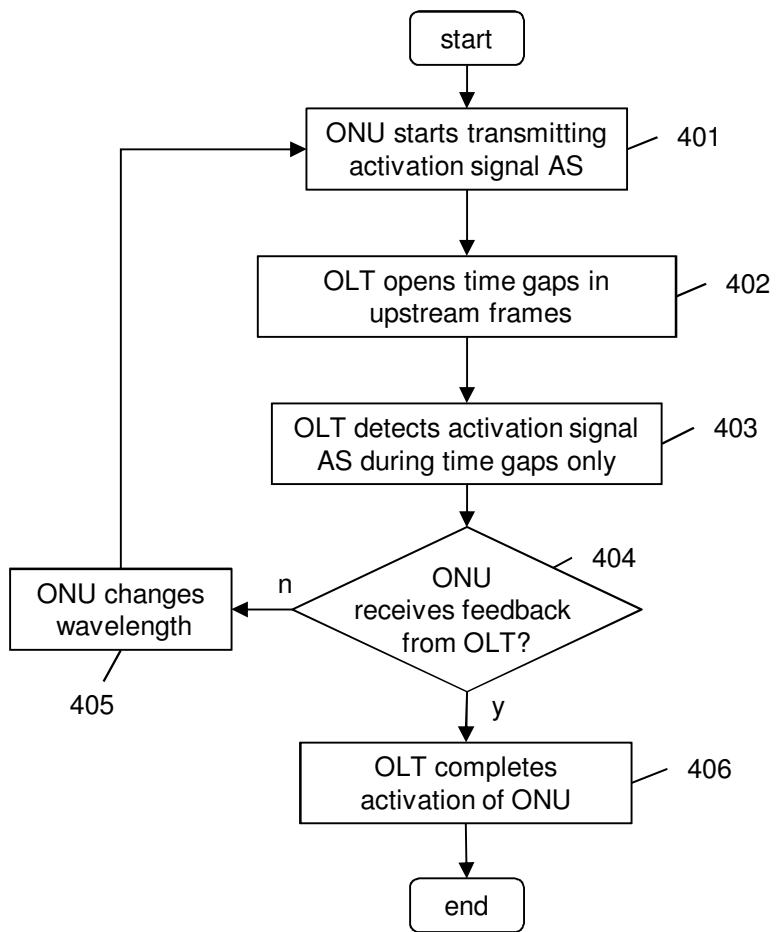

Figure 2

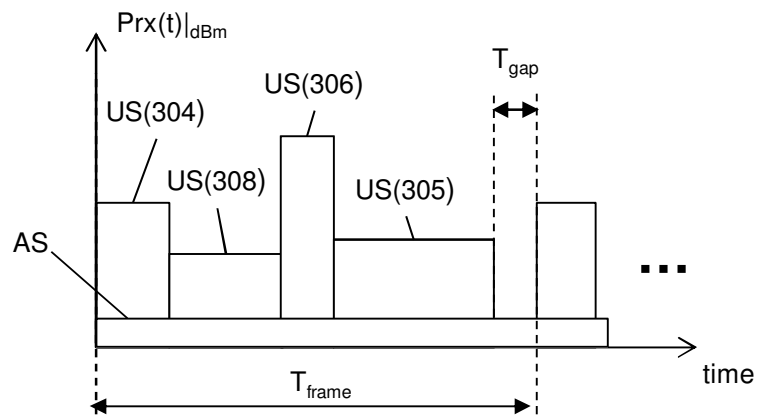

Figure 3

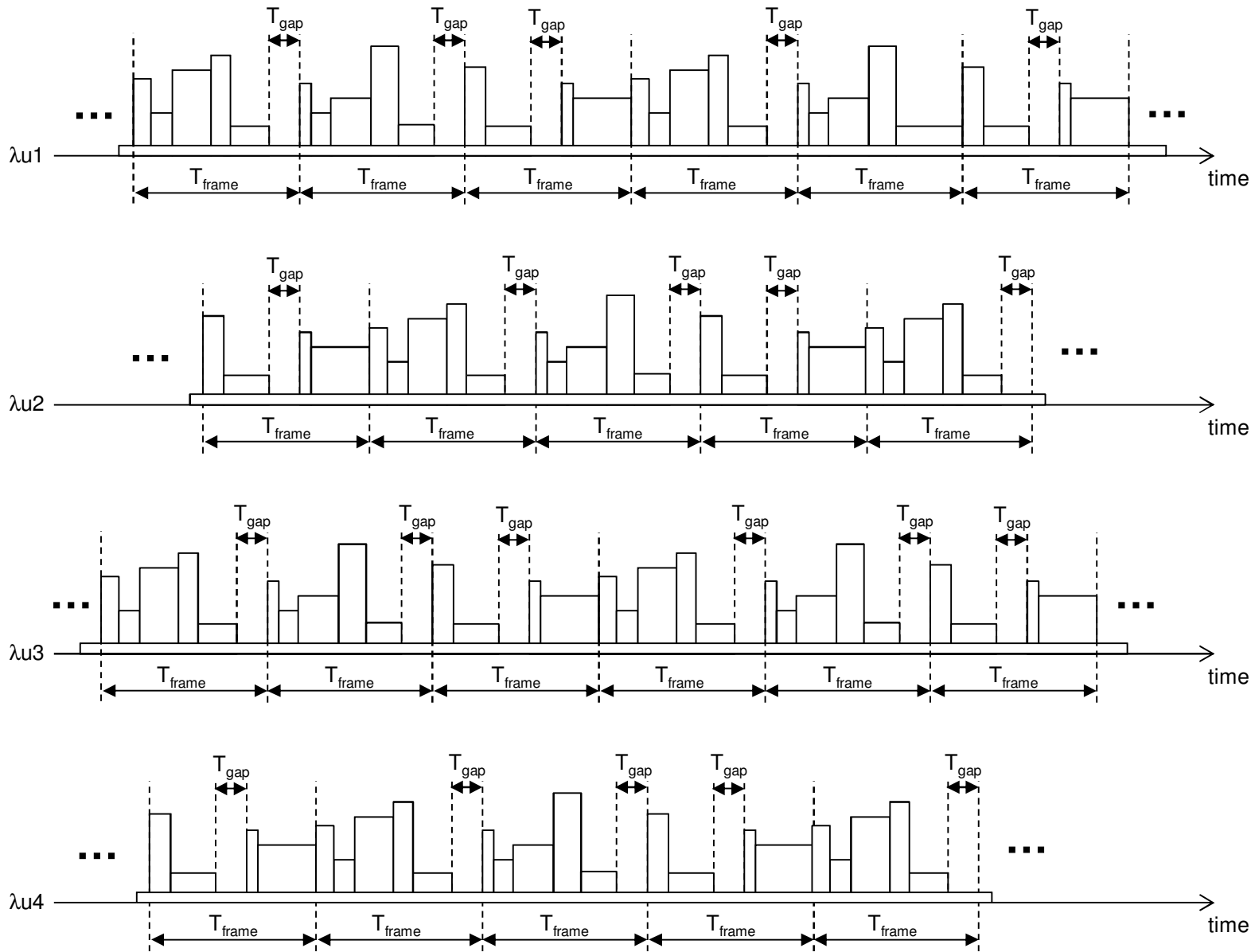

Figure 4

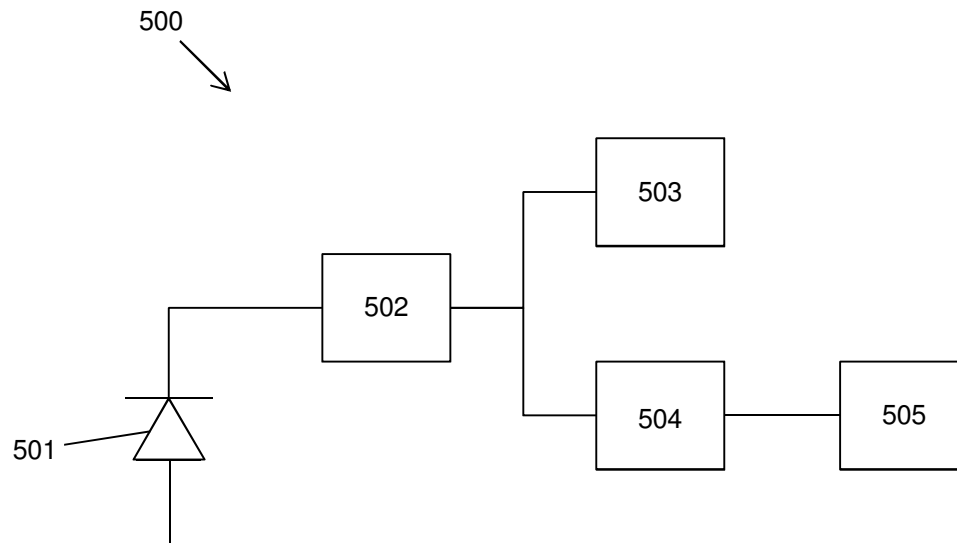

Figure 5

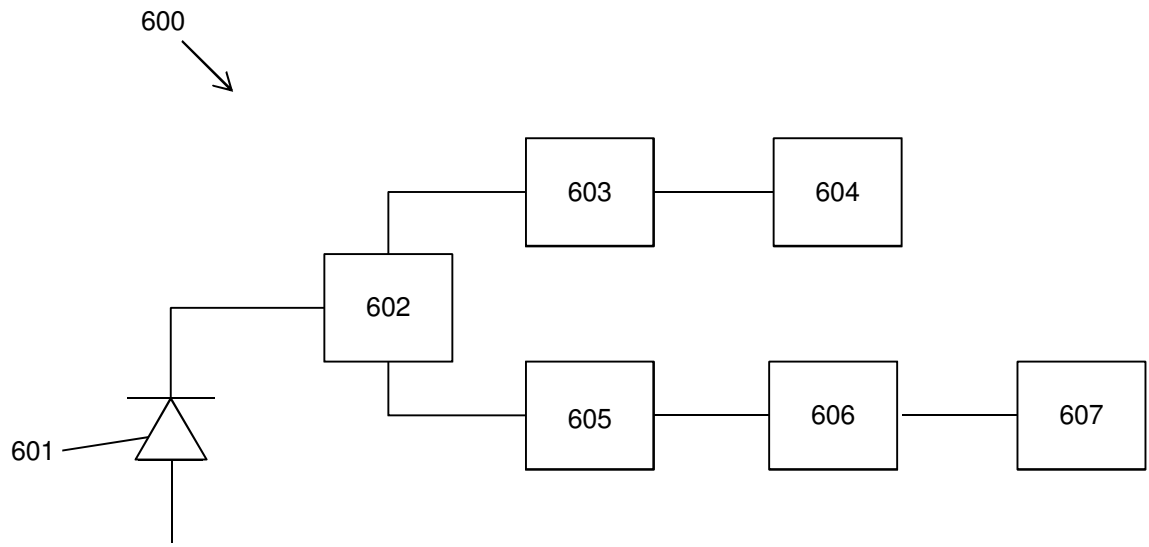

Figure 6