

Recent advances in the method of moments to model surface junctions

Original

Recent advances in the method of moments to model surface junctions / Lombardi, Guido; Graglia, Roberto. - ELETTRONICO. - (2015), pp. 1162-1163. (Intervento presentato al convegno Antennas and Propagation Society International Symposium (APSURSI), 2015 IEEE tenutosi a Vancouver, BC, Canada nel July 19-24, 2015) [10.1109/APS.2015.7304969].

Availability:

This version is available at: 11583/2627696 since: 2016-01-11T16:21:56Z

Publisher:

IEEE - INST ELECTRICAL ELECTRONICS ENGINEERS INC

Published

DOI:10.1109/APS.2015.7304969

Terms of use:

This article is made available under terms and conditions as specified in the corresponding bibliographic description in the repository

Publisher copyright

(Article begins on next page)

Recent Advances in the Method of Moments to Model Surface Junctions

Guido Lombardi

Department of Electronics and Telecommunications
Politecnico di Torino
Torino, Italy
guido.lombardi@polito.it

Roberto D. Graglia

Department of Electronics and Telecommunications
Politecnico di Torino
Torino, Italy
roberto.graglia@polito.it

Abstract— This paper summarizes and disseminates our efforts in developing new techniques to handle singularities in the Method of Moment. In this context singularities are due to mathematical formulation of the problem in terms of integral equations and to the physical properties of the electromagnetic quantities at geometrical/material discontinuities. One of these cases is the surface junction among plates.

I. INTRODUCTION

The method of moments (MoM) is one of the most widely used numerical techniques for solving scattering and radiation problems. The classical scheme with the traditional Rao-Wilton-Glisson (RWG) basis functions [1] has been partially extended to handle complex structures with metallic plates joined together [2]-[6] that generate surface junctions defined at the connection points among different plates. Frequently the connection among plates involves sharp edge structures whose modeling is not considered in the current literature. Indeed real-life complex targets present surface junctions typically constituted by sharp edge plates as for examples wings, fins, winglet of air vehicles or electronic manufactures (for instance heat-sinks).

This problem involves: 1) the sharpness of the geometry that may excite electromagnetic singularities, 2) the singularity of the Green's function in the mathematical formulation of the problem through integral equations, 3) the connection among plates that creates a new constraint among the physical unknowns.

II. MODELLING SHARP GEOMETRIES

Recently, the authors of this paper have extended the method of moments (MoM) [7] to handle structures with sharp edges [8]-[13] where the charge and the current densities show singular behaviors [14]-[15].

In [11] additive singular divergence-conforming vector bases are capable to model the electromagnetic singularities. We recall that the additive scheme augments the degree of freedoms for the element connected to sharp edges by introducing edge singular elements and vertex singular

elements with special singular vector functions defined in parent domain. For a complete treatise, please refer to [11].

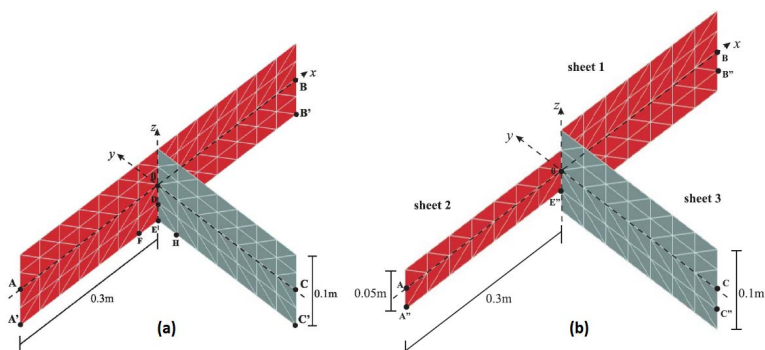

Fig. 1. T-shape surface formed by joining three zero-thickness rectangular plates: (a) three plates with same size, (b) one of the three plates described in (a) is resized (sheet 2).

III. THE SINGULARITY OF THE GREEN'S FUNCTION

Potential integrals with unbounded singular kernels arise in the moment-method solution of the integral equations of electromagnetism whenever the source and the testing subdomain coincide, that is, in the so-called self-term case. The integrals become nearly singular if the source and testing subdomains are very close to each other, but do not overlap.

Recently, we have developed a new singularity cancellation technique [16] that allows to obtain machine precision results and anticipate the precision of the numerical results in terms of sample points. This technique is based on variable transformations whose Jacobian cancels out the singularity of the integral kernel. The superiority of the cancellation method with respect to the subtraction method is established for example in [16]-[17].

IV. MODELLING SURFACE JUNCTIONS

The junction problem among plates is two-fold and it can be classified in: (a) sharp edge plates joined to sharp edge plates (plate-to-plate junctions), (b) sharp edge plates joined to or merged in a smooth surface (plate-to-surface junctions). Fig. 1 illustrates these two cases.

As stated in our recent paper [18] both the junctions of Fig. 1 contain corner-points (for instance in Fig. 1(a) point E' and in Fig. 1(b) point E''). One of the major numerical difficulties is in modeling the current density near this kind of point where one cannot resort to any analytical method to predict the current density behavior.

We recall that, on infinitely thin plates, the current density tangent to the edge-profiles could be singular at the edges and it is expected to be probably singular also at the corner-point.

Moreover, to enforce the correct mathematical/physical model we need to guarantee the current continuity along the line of junction (in Fig. 1 the line of junction is the z axis).

In the neighborhood of the corner-point we need two different approach to model the current density: one for the case of plate-to-plate junctions (Fig. 1(a)) and one for the plate-to-surface junctions (Fig. 1(b)). In particular in the second case the infinite current density running along the edge has to flow out on a surface at the corner-point (in Fig.1(b) the surface is constituted by sheets 1 and 3).

In [18] we propose a complete procedure to handle junctions in presence of sharp edges in surface integral equation method by defining the required basis functions and unknowns. In particular we show how to incorporate higher order interpolatory vector functions and singular vector functions in MoM codes when surface junctions are present exploiting the additive property of the bases. This procedure is based on the application of Kirchhoff's current law in terms of degrees of freedoms (coefficients of basis functions).

In particular, for the region near a corner point, in case of plate-to-surface junctions, we have defined new singular elements that model properly the transition region. In this scheme the edge-aligned strong half-vertex singular elements [18] are used in the element connected to the corner point inside the surface.

These singular elements require high precision integration tools for double singular integrals (singularity of the Green's function and singularity of the basis functions) that are derived through the methods proposed in [16], [19].

Several numerical tests will be presented at the conference to validate our procedure.

REFERENCES

- [1] S.M. Rao, D.R. Wilton, A.W. Glisson, "Electromagnetic scattering by surfaces of arbitrary shape," *IEEE Trans. Antennas Propagat.*, vol. AP-30, pp.409-418, May 1982.
- [2] B.M. Kolundzija, "Electromagnetic modeling of composite metallic and dielectric structures," *IEEE Trans. Microw. Theory Techn.*, vol.47, no.7, pp.1021-1032, Jul 1999.
- [3] J. Shin, A. W. Glisson, and A. A. Kishk, "Modeling of general surface junctions of composite objects in an SIE/MoM formulation," in *Proc. 2000 ACES Conf.*, pp. 683-690.
- [4] M.A. Carr, E. Topsakal, J.L. Volakis, and D.C. Ross, "Adaptive integral method applied to multilayer penetrable scatterers with junctions," *IEEE Antennas Propag. Soc. Int. Symp.*, 2001, vol. 4, pp. 858-861.
- [5] M. Carr, E. Topsakal, J.L. Volakis, "A procedure for modeling material junctions in 3-D surface integral equation approaches," *IEEE Trans. Antennas Propagat.*, vol.52, no.5, pp. 1374-1378, May 2004.
- [6] P. Ylä-Oijala, M. Taskinen, and J. Sarvas, "Surface integral equation method for general composite metallic and dielectric structures with junctions," *Progress In Electromagnetics Research*, Vol. 52, 81-108, 2005.
- [7] R.D. Graglia, D.R. Wilton, A.F. Peterson, "Higher order interpolatory vector bases for computational electromagnetics," *IEEE Trans. Antennas Propag.*, Special Issue on Adv. Numer. Tech. Electromagn., vol. 45, no. 3, pp. 329-342, Mar. 1997.
- [8] R.D. Graglia, G. Lombardi, "Singular higher order complete vector bases for finite methods," *IEEE Trans. Antennas Propagat.*, vol.52, no.7, pp. 1672-1685, July 2004, doi: 10.1109/TAP.2004.831292
- [9] R.D. Graglia, G. Lombardi, "Vector functions for singular fields on curved triangular elements, truly defined in the parent space," in *IEEE Antennas Propag. Soc. Int. Symp.*, 2002, vol.1, pp.62-65, doi: 10.1109/APS.2002.101625
- [10] R.D. Graglia, G. Lombardi, D.R. Wilton, W.A. Johnson, "Modeling edge singularities in the method of moments in IEEE Antennas Propag. Soc. Int. Symp., 2005, vol.3A, pp. 56- 59, 3-8 July 2005, doi: 10.1109/APS.2005.1552172
- [11] R.D. Graglia, G. Lombardi, "Singular Higher Order Divergence-Conforming Bases of Additive Kind and Moments Method Applications to 3D Sharp-Wedge Structures," *IEEE Trans. Antennas Propagat.*, vol.56, no.12, pp. 3768-3788, Dec. 2008, doi: 10.1109/TAP.2008.2007390
- [12] G. Lombardi, R.D. Graglia, "Singular higher order vector bases for wedge-structure MoM-models: The simple recipe," *Electromagnetics in Advanced Applications*, 2009. ICEAA '09. International Conference on, pp.1082-1085, 14-18 Sept. 2009, doi: 10.1109/ICEAA.2009.5297790
- [13] D. Erricolo, R.D. Graglia, G. Lombardi, T. Stoa, P.L.E. Uslenghi, "Benchmark targets for Computational Electromagnetics programs modeling structures with edges," in *IEEE Antennas Propag. Soc. Int. Symp.*, 2010, pp.1-4, 11-17 July 2010, doi: 10.1109/APS.2010.5561957
- [14] J. Meixner, "The behavior of electromagnetic fields at edges," *IEEE Trans. Antennas Propagat.*, vol. AP-20, no. 4, pp.442-446, July 1972.
- [15] J. Van Bladel, *Singular Electromagnetic Fields and Sources*. Oxford, U. K.: Clarendon, 1991.
- [16] R.D. Graglia, G. Lombardi, "Machine Precision Evaluation of Singular and Nearly Singular Potential Integrals by Use of Gauss Quadrature Formulas for Rational Functions," *IEEE Trans. Antennas Propagat.*, vol.56, no.4, pp.981,998, April 2008, doi: 10.1109/TAP.2008.919181
- [17] M.A. Khayat and D.R. Wilton, "Numerical evaluation of singular and near-singular potential integrals," *IEEE Trans. Antennas Propag.*, vol. 53, pp. 3180-3190, Oct. 2005.
- [18] G. Lombardi, R.D. Graglia, "Modeling Junctions in Sharp Edge Conducting Structures With Higher Order Method of Moments," *IEEE Trans. Antennas Propagat.*, vol.62, no.11, pp.5723,5731, Nov. 2014, doi: 10.1109/TAP.2014.2355855
- [19] G. Lombardi, "Design of quadrature rules for Muntz and Muntz-logarithmic polynomials using monomial transformation," *International Journal for Numerical Methods in Engineering*, pp. 1687-1717, Vol. 80, n.13, 2009, doi: 10.1002/nme.2684