

Performance Assessment of a Solar Assisted Ground Source Heat Pump in a Mountain Site

Original

Performance Assessment of a Solar Assisted Ground Source Heat Pump in a Mountain Site / Fabrizio, Enrico; Ferrara, Maria; Urone, Giampiero; Corgnati, STEFANO PAOLO; Pronsati, Simone; Filippi, Marco. - In: ENERGY PROCEDIA. - ISSN 1876-6102. - 78:(2015), pp. 2286-2291. [10.1016/j.egypro.2015.11.366]

Availability:

This version is available at: 11583/2627403 since: 2016-01-07T19:14:26Z

Publisher:

Elsevier

Published

DOI:10.1016/j.egypro.2015.11.366

Terms of use:

This article is made available under terms and conditions as specified in the corresponding bibliographic description in the repository

Publisher copyright

(Article begins on next page)

6th International Building Physics Conference, IBPC 2015

Performance assessment of a solar assisted ground source heat pump in a mountain site

Enrico Fabrizio^{a*}, Maria Ferrara^b, Giampiero Urone^b, Stefano P. Corgnati^b,
Simone Pronsati^c, Marco Filippi^b

^aDISAFA, University of Torino, Largo Paolo Braccini 2, 10095 Grugliasco (TO), Italy

^bDENERG, Politecnico di Torino, Corso Duca degli Abruzzi 24, 10129 Torino, Italy

^cGEONOVIS srl, S.S. 11 km 46,500, 13040 Borgo D'Ale (VC), Italy

Abstract

Systems based on the integrated use of multiple renewable energy sources, such as “Solar Assisted Geothermal Heat Pumps” (SAGHPs), seem to increase efficiency and overcome limits of the use of traditional heat pump systems. In this work, a SAGHP providing energy for heating and DHW of a newly built restaurant in an Alpine ski park was analyzed through transient simulations with TRNSYS[®], following the collection of information about the system component, the operation and the weather conditions of the mountain site. The annual energy balance allowed different system operation modes to be compared.

© 2015 The Authors. Published by Elsevier Ltd. This is an open access article under the CC BY-NC-ND license (<http://creativecommons.org/licenses/by-nc-nd/4.0/>).

Peer-review under responsibility of the CENTRO CONGRESSI INTERNAZIONALE SRL

Keywords:

1. Introduction

Systems for Zero Energy Buildings are based on a multi-carrier/multi-converter logic (a mix of energy sources feeds two or more energy converters to cover the energy loads) [1]. Solar Assisted Ground Source Heat Pumps (SAGHPs) exploit the combination of two different renewable sources such as solar energy and low enthalpy geothermal energy for the production of hot water and for the space heating of residential and commercial users. Solar energy is exploited through solar collectors that convey the energy incident on the surface into the heating of a

* Corresponding author. Tel.: +0-000-000-0000 ; fax: +0-000-000-0000 .
E-mail address: author@institute.xxx

heat transfer fluid. Geothermal energy comes from the exploitation of the natural geothermal gradient of the surface layers of the earth's crust. The high thermal inertia of the ground allows a volume of soil to act as a thermal reservoir at a low temperature that can regenerate itself in relation to the weather conditions, the thermo-physical characteristics of the soil and the kind of energy exploitation itself.

The benefits of SAGHP systems are numerous and are closely related to the type, configuration and operation of the system [2]. Compared to systems that use only the technology of geothermal heat pumps (GHP), in SAGHP systems, with equal users requirements, the amount of heat extracted from the geothermal source is lower, thanks to the simultaneous production of thermal energy from the solar collectors. This allows reducing the hours of operation of the heat pump, regenerating the geothermal source and having a lower overall energy consumption of the system.

The design of innovative multi-source multi-product systems such as SAGHPs involves the use of energy storage systems that are able to optimize the whole system operation and the exploitation of energy from renewable sources or wastes. Many possibilities exist as to the use of the solar source in a SAGHP, depending on the climate conditions and on the characteristics of the energy demand supplied by the system. This is why various system layouts, uses and operation parameters of the storage (temperature, water types, hydraulic connections, etc) can be defined and should be optimized at the design stage by means of dynamic simulation.

A large number of experimental projects on such systems have been developed between the 80s and the 90s, and different types of systems have been analyzed from a theoretical perspective. These systems have been the focus of an international research project of the International Energy Agency (SHC program, TASK44). In recent years, thanks to the improved performance and the costs reduction of the various components, SAGHP systems finally reached commercial distribution. One of the main points of a SAGHP is that there are many systems configurations and different loops that can be adopted. Most of them use one or more thermal energy storage (necessarily the solar system but also for the heat pump), so a key role in the performance of such systems is played by the energy storage.

In order to give an immediate representation of the characteristics of such a system, Frank et al [3], proposed a Square View that identifies each possible system as reported in Fig. 1a for the case study. The diagram shows in the central part the main components of the system (solar collectors, heat pump, storages, backup), on top the renewable sources that are available, on the right the user energy demands and on the left the non-renewable sources. Arrows of different types interconnect the various blocks as a function of the energy carrier (energy, water, refrigerant, etc.).

Another primary feature that is needed to identify a SAGHP system, is the mode of exploitation of the solar energy, which quantifies the degree of integration between the heat pump and the solar thermal collectors. The classification proposed by various authors [3],[4] divides the systems into "parallel" and "serial". Parallel systems are characterized by the fact that the solar collectors and the heat pump provide heating energy in parallel to one or more heat storages. This means that in practice there are no physical connections between the two subsystems, if not in the storage and end-uses. Serial systems are characterized by the fact that the thermal energy made available by solar thermal collectors is used as a heat source at low temperature, directly or indirectly, by the heat pump. In this case, there is a physical connection between the two subsystems.

In this work, a system that uses a ground source heat pump integrated with solar thermal collectors that is at the service of a specific user located in an alpine high altitude was analyzed. The plant is going to meet the energy needs for the fresh air heating, the DHW heating and the space heating of a newly built restaurant located inside a ski park. The use of the platform TRNSYS allowed to construct a model of both the building and the system and to perform short and long term transient simulations to assess the energy consumption and the energy performance of different configurations and operation modes of the system. The peculiarity of this case study is that also the recovery from the grey DHW is applied and that there are storages at both the source side (one for grey DHW and one for solar and energy recovery from the grey DHW) and user side (Fig.1a: one for hot water at high temperature for space heating "HT tank", one for hot water at lower temperature for space heating "LT tank", and one for DHW "DHW tank").

2. The case study and the modeling assumptions

In the present paper, the global performance of a SAGHP, which is a real case-study located in the high Alps region is assessed by means of dynamic simulation. The location can be considered as "extreme" since the system is placed at 2500 m above sea with rigid winter climate conditions (the annual degree days are 4524 °Cd and the winter design temperature is set to -20 °C) and – the electricity from the grid taken apart – a limited availability of

energy sources. The square view of the system can be found in Fig. 1. The system is based on the use of the thermal output of the solar collectors in the ground loop in order to increase the operating temperatures at the evaporator side of the heat pump and to regenerate the ground. A system intended to recover the heat from gray DHW is also designed. A thermal storage of ground loop water (called intermediate storage, “int tank” in Fig. 1) is therefore equipped with two heat exchangers, one for the solar collectors primary loop and one for the recovery system of DHW primary loop. Different regulations may be implemented in order to maximize the exploitation of the solar and waste energy sources and increase the global efficiency of the system. After studying the whole system design and the boundary conditions, a detailed model for the dynamic simulation of the system into the TRNSYS software tool was created. Before the completion of the real system installation, the first simulation runs allowed to check the feasibility of the system and refine the system design.

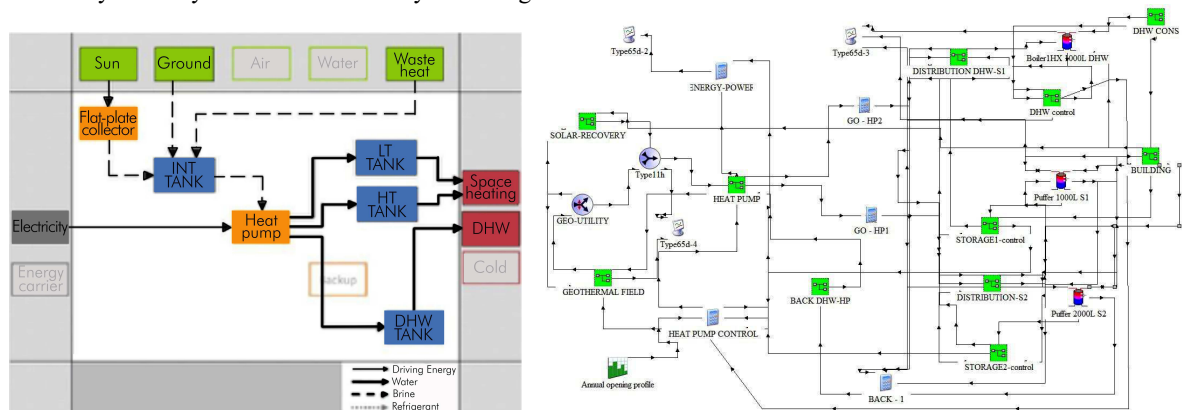

Fig. 1. (a) Square view of the SAGHP system under consideration; (b) Building-system TRNSYS model in the Simulation Studio interface

2.1. The building model

Using the TRNSYS Type 56 and its TRNBuild interface, the building was modeled into eight thermal zones, each corresponding to a building room. Five of them (group of zones A) are people occupied conditioned zones, where the design set point temperature is set to 20 °C during the day and 16 °C during the night. Floor radiant panels provide heating to this group of zones, which is located in the south part of the building and have the net floor area equal to 330 m² and the net heated volume equal to 890 m³. Other zones (group of zones B), whose floor area is equal to 260 m², are not conditioned, however hot air is supplied by vents to maintain the anti-glaze set point temperature of 12 °C. The building is supposed to be occupied in winter (from 1st November to 30th April) from 8 am to 6 pm and its maximum occupancy capacity is 100 people during peak hours (from 10 am to 2 pm). During the highest occupancy, the ventilation rate is set to 9.75 ach, which correspond to 4800 m³/h to be provided by a mechanical ventilation system. Daily and weekly schedules modify the occupancy and the related ventilation rate, according to typical occupancy profiles for the commercial and restaurant building uses. The group of zones A is delimited by a highly insulated external envelope with a wooden structure. The average thermal transmittance values are: $U_{\text{wall}} = 0.16 \text{ W/m}^2\text{K}$ for the external walls, $U_{\text{roof}} = 0.15 \text{ W/m}^2\text{K}$ for the roof and $U_{\text{floor}} = 0.29 \text{ W/m}^2\text{K}$ for the ground floor. The walls dividing zones A from zones B have $U = 0.21 \text{ W/m}^2\text{K}$. The surfaces delimiting group of zones B have a concrete structure and a thermal transmittance equal to 0.13 W/m²K. Most of the glazed surface is located on the south façade, in order to benefit from solar gains in the people occupied zones. All the windows are made with triple glazing, having $U = 1.27 \text{ W/m}^2\text{K}$ and no fixed solar shadings.

Given these features, the total seasonal energy demand of the building is equal to 119027 kWh, of which 45936 kWh are needed for space heating, 59620 for the fresh air heating and 13471 kWh for the domestic hot water production. During the design day (15 January), the total energy demand is equal to 351 kWh, and:

- the peak heating rate for DHW production is 3.88 kW (there is a storage tank of 1000 litres);
- the peak heating rate for space heating is 21 kW;
- the peak heating rate for air treatment is 20 kW.

The model of the system is composed by two main parts that are the evaporator loop (on the left in Fig. 1b) and the use side loop (on the right in Fig. 1b). Many TRNSYS types were used to model the system and in particular:

- Type 1, which allows to model the performance of multiple flat plate solar collectors that are linked in series or in parallel. Each solar collector has an area of 2.15 m² and $\eta_0 = 0,806$, $a_1 = 4,164 \text{ W}/(\text{m}^2\text{K})$, $a_2 = 0,0098 \text{ W}/(\text{m}^2\text{K}^2)$.
- Type 668, which allows to model a water/water heat pump by performing a linear interpolation on user-defined manufacturer data. A 60 kW double stages (two compressors) heat pump was modeled according to EN 14511 with COP(0/35)=4.09 and COP(0/45)=3.35; the design water flow rate at the condenser is 1.34 l/s; the design water flow rate at the evaporator is 2.90 l/s. The regulation of the heat pump is ON-OFF on each compressor.
- Type 557 for the ground heat exchanger. There are 6 boreholes of 200 m of length for a total of 1200 m with single U-tube of 40 mm diameter made of PE-100. The soil thermal conductivity soil is 1.9 W/(mK) and the soil heat capacity is 2.0 MJ/(m³K). The initial surface ground temperature is 0.5 °C with a vertical thermal gradient of 0.03 K/m. The boreholes are connected in parallel and placed in two rows (3+3). The nominal water flow rate of each borehole is 0.483 l/s.
- Type 60 for stratified (8 nodes) fluid storage tanks with internal coils. There are 5 water thermal storages in the whole system. HT tank (Fig. 1a) is a 2000 l puffer at a temperature between 60 and 45 °C; LT tank is a 1000 l puffer at a temperature between 40 and 25 °C; DHW tank is a domestic hot water boiler of 1000 l with a internal heat exchanger of 9 m². INT tank (Fig. 1^o) is a 500 l storage with two internal coils, one of 2 m² for the solar integration on the top and one of 2.2 m² for the waste DHW recovery on the bottom. A basin for the waste DHW is modelled as a storage of 4152 l with an internal coil of 9 m².

The regulation of the heat pump heating of the three storages is based on the degree-minute of heating requirements of the LT, HT and DHW tanks. The heat pumps activates and supply heating energy to a storage when a value of 100 °Cmin (computed with reference to the maximum temperature of the storage) is reached. The second stage of the heat pump is used only for the HT tank and activates when the heating requirement reaches 50 °Cmin.

The test meteorological year (TMY) of the specific location was downloaded from the Solar Project database. The mean annual outdoor air temperature is equal to 0.6 °C while the mean outdoor air temperature of the heating season (from 1st November to 30th April) is equal to – 3.8 °C. The design outdoor air temperature is equal to –20 °C.

3. Results

3.1. System configurations (SCs)

In order to study the design of the system in this particular weather condition, the simulations were organized as follows. First of all, 6 different systems configurations (SCs), that can be organized into three different types, were defined varying the system configuration as follows:

- SC 0 – GHP: this is a simple ground source heat pump system (GHP) with no integration whatever;
- SC 1 – serial SAGHP: this is a set of three different SAGHP in serial where the energy recovery from waste DHW and solar collectors is stored into a storage tank (“INT tank” of Fig. 1a) where it is used to increase the temperature of the water into the geothermal loop. This is realized because the water at the outlet of the geothermal loop goes through this storage tank to be heated before going to the evaporator of the heat pump. For SC 1.1 the only the solar collectors are used; for SC 1.2 only the recovery from wasted DHW is used, while for SC 1.3 both sources are present.
- SC 2 – SAGHP in parallel with DHW: in this case the solar energy is used for a pre-heating of the DHW.
- SC 3 – SAGHP in parallel with the space heating at low temperature: in this case the solar energy is used for a pre-heating of the LT tank (Fig. 1).

The number of solar collectors was firstly fixed at 4.

For each SC, both a seasonal simulation and a 10-years simulation were done in order to investigate how the solar and heat recovery sources may contrast the thermal depletion [5] of the ground and reduce the system loss of efficiency. In case of multiple-years simulations, also the option of the charging of the ground with solar energy produced during the period 1st May – 31st October can be investigated.

3.2. Seasonal simulations

As can be seen from the results reported in Table 1, the seasonal amount of energy extracted from the ground by the boreholes (Q_G) is decreasing in case of the SAGHP configurations, however, given the amount of the energy from solar and wasted water, the reductions are quite small. The solar energy exploited and the energy recovered from the waste DHW are reported into the Q_{SOL} and Q_{WW} columns respectively, and are computed considering the net amount of energy that is released to the intermediate storage tank (INT tank of Fig. 1a). As regards the solar energy, the maximum amount can be found in SC 1.1 or 1.3 where the working temperature of the primary loops of the solar collectors is lowered since the use side heat exchanger is placed into the INT tank which is at a temperature lower than the LT tank and DHW tank. This can also be appreciated by the mean seasonal efficiency of the solar system (η_c), that for SC 1 is greater than the one of SC 2 or SC 3 where thermal energy is to be used for heating purposes instead. The energy that can be recovered from the waste DHW is merely the same in SC 1, while it falls to low values in case SC 2 and especially SC 3 because of its low temperature level. The heat pump electricity (E_{HP}) does not show significant variations, especially if one takes into account also the electricity consumed by auxiliaries (E_{aux}) in case of SAGHP configurations and computes the total (E_{tot}). As regards the seasonal COP of the heat pump, the SAGHP in serial configurations assure a slight increase which is due to the fact that the temperature at the evaporator is slightly higher (no more than 1 °C however), while this has no effect in SC 2 and 3.

Table 1. Results of the seasonal simulation of the various SCs.

	Q_G [kWh]	Q_{SOL} [kWh]	Q_{WW} [kWh]	E_{HP} [kWh _e]	E_{aux} [kWh _e]	HP operation time [h]	SCOP [-]	η_c [-]	E_{tot} [kWh _e]
SC 0	71444	0	0	27861	0	2622	3.57	-	27861
SC 1.1	68611	4111	0	27833	74	2601	3.62	0.734	27908
SC 1.2	64000	0	7453	27578	216	2590	3.60	-	27794
SC 1.3	60833	3750	7389	27528	289	2585	3.62	0.670	27817
SC 2	68306	2464	2194	26667	151	2567	3.57	0.440	26818
SC 3	69083	2353	556	27333	73	2590	3.53	0.420	27405

If in case of SC 2 and SC3, parallel systems, the sizing of the solar collectors should be done as a function of the users heating energy demand, while in case of SC 1, serial systems, 4 solar collectors appear clearly to be not sufficient to exploit the benefits of the SAGHP configuration. Therefore, for the SC 1.3 an increase of the number of the solar collector was studied and the results are reported in Table 2. As it can be seen, the SCOP increases up to 3.84 (+ 7 % with reference to the one of the GHP system) and the global electricity demand is lowered by 5 %.

Table 2. Results of the SC 1.3 with an increased number of solar collectors.

N solar collectors	Q_G [kWh]	Q_{SOL} [kWh]	Q_{WW} [kWh]	E_{HP} [kWh _e]	E_{aux} [kWh _e]	HP operation time [h]	SCOP [-]	η_c [-]	E_{tot} [kWh _e]
10	56027	9922	7591	27111	309	2528	3.71	0.708	27816
20	46777	19002	7466	26250	313	2474	3.79	0.668	26575
30	39250	27205	7338	25961	336	2456	3.84	0.647	26297

3.3. Multi-year simulations

This part of the paper reports the results of the 10-years simulations that were done in order to identify variations in the ground temperature due to the heat extracted from the soil and the solar energy and waste water recovery. The thermal simulation was conducted for 87600 hours but the operation time of the system is still fixed at the period 1st November – 30th April of each year (in the remaining part of the year the system is simply shut off). In the case of the GHP systems and SC 2 and 3 (parallel SAGHP), the SCOP (Table 3) shows a reduction of about 2 % after 10 years due to the thermal depletion of the ground (from 3.2 °C to 0.5 °C). It is interesting to note that in case of

SCs 1, the final average ground temperature can be maintained at 1 °C (see the variations in the average ground temperature reported in Fig. 2 for SC 1.3 and for the base case of the sole GHP).

In any case, better performances can be obtained by using the solar thermal system in summer and charging the ground with the solar energy. In Table 2 the results at the 10th operation year of the system SC 1.3 without and with the summer thermal charging of the ground are reported. By using solar energy to charge the ground in summer it is possible to contrast the SCOP reduction. After 10 years of operation the SCOP of the SC 1.3 with the summer thermal charging is merely equal to the SCOP of the base GHP system at the first year of operation (3.56). This means that the effects of the reduction of the ground temperature due to the operation of the heat pump are cancelled, with a mean ground temperature of 1.2 °C. However, due to an increase of the electricity use for the auxiliaries, in particular for the pump that circulates the geothermal fluid in the boreholes, from the simple point of view of the energy use this configuration may seem not profitable (28402 > 28142 kWh).

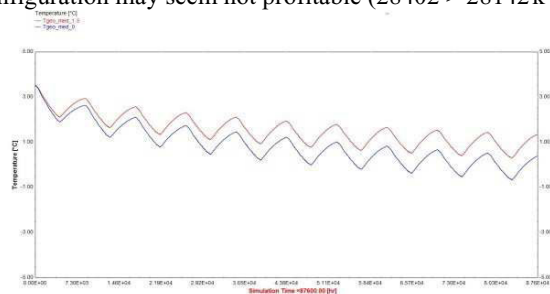

Fig. 2. 10-years temperature evolution of the ground for the GHP (blue) and the SAGHP SC 1.3 (fuchsia) cases.

Table 3. Results of the seasonal simulation of SC 0 and of SC1.3 without (w/o) and with (w) the summer thermal charging mode at 10th year.

	Q_G [kWh]	Q_{SOL} [kWh]	Q_{WW} [kWh]	E_{HP} [kWh _e]	E_{aux} [kWh _e]	HP operation time [h]	SCOP [-]	η_c [-]	E_{tot} [kWh _e]
SC 0	70090	0	0	28142	0	2683	3,49	-	28142
SC 1.3 w/o	59166	3900	7838	27908	293	2636	3,54	0.696	28201
SC 1.3 w	59453 – 7175 (charging)	3886 +7175	7815	27844	558	2629	3.56	0.782	28402

4. Conclusions

A SAGHP system for a particular cold location was studied by means of transient simulation. Results show that solar integration is profitable from the energy point of view only if it is sufficiently large to cover a great portion of the energy that is exchanged by the heat pump at the evaporator. The real system is under construction so the model of the system may be calibrated against measured data and an optimization of the design variables (storage volumes, storage temperatures, etc.) may be implemented coupling an optimization algorithm to the model of the system.

Acknowledgment

The authors would like to thank Geonovis srl for providing useful information and data for this work.

References

- [1] Fabrizio E, et al. Integrated HVAC and DHW production systems for Zero Energy Buildings. *Renew Sust Energ Rev* 2014;40:515-541.
- [2] Ozgener O, Hepbasli A. A review on energy and exergy analysis of solar assisted heat pump systems. *Renew Sust Ene Rev* 2007;30:482-496.
- [3] Frank E, Haller M, Herkel S, Ruschenburg J. Systematic classification of combined solar thermal and heat pump systems. In: Proc. of the EuroSun 2010 Conference, Graz, Austria.
- [4] Trinkl C, Zörner W, Hanby V. A review on solar assisted heat pump systems for domestic heating. *Proceedings of EuroSun Conference, 2004, Freiburg, Germany.*
- [5] Trillat-Berdal V. et al. Coupling of geothermal heat pumps with thermal solar collectors. *Appl Therm Eng* 2007;27:1750-1755.