

Switching node architectures in flexible-grid networks: A performance comparison

Original

Switching node architectures in flexible-grid networks: A performance comparison / Ahmad, Arsalan; Bianco, Andrea; Bonetto, Edoardo; GARRICH ALABARCE, Miquel; J. R. F., Oliveira. - STAMPA. - (2014), pp. 49-54. (Intervento presentato al convegno ONDM 2014 - International Conference on Optical Network Design and Modeling tenutosi a Stockholmm, Swedeb nel May 2014).

Availability:

This version is available at: 11583/2582348 since:

Publisher:

IFIP

Published

DOI:

Terms of use:

This article is made available under terms and conditions as specified in the corresponding bibliographic description in the repository

Publisher copyright

(Article begins on next page)

Switching Node Architectures in Flexible-grid Networks: a Performance Comparison

Arsalan Ahmad, Andrea Bianco, Edoardo Bonetto
Department of Electronics and Telecommunications,
Politecnico di Torino, Torino, Italy
Email: {firstname.lastname}@polito.it

Miquel Garrich, Juliano R.F. Oliveira
CPqD Foundation,
Campinas, SP, Brazil
Email: miquel@cpqd.com.br

Abstract—A migration from fixed-grid WDM networks to flexible-grid networks is foreseen as a solution able to cope with the constant traffic increase in backbone networks. The migration will involve significant changes in the network infrastructure and in the architecture of optical switching nodes. Indeed, several studies propose new architectures that can effectively exploit the characteristics of flexible-grid networks. On the one hand, traditional ROADM nodes enhanced with new colorless, directionless and contentionless capabilities are studied. On the other hand, nodes designed according to the Architecture on Demand concept were proposed as a solution able to dynamically adapt to the elastic switching and processing requirements of flexible-grid networks. We evaluate the two node architectures considering their use in flexible-grid networks and we compare their spectral efficiency and energy consumption.

I. INTRODUCTION

Internet traffic is continuously growing due to new bandwidth-hungry services and applications, supported by either wireless or Fiber-To-The-x (FTTx) based broadband access technologies, which ensure high speed connectivity to end-users. However, this traffic growth must also be supported in metro and core network segments. Thus, operators are forced to continuously upgrade their infrastructures adding more capacity to the network infrastructure by installing new optical transmission and electronic switching equipment, significantly increasing network energy consumption.

In this challenging context, flexible grid spectrum allocation (ITU-T Recommendation G.694.1 [1]) could be a viable solution to sustain the increasing traffic requirements at lower energy costs. Indeed, flexible grid spectrum allocation can permit the coexistence of both legacy low bit-rates and future high-speed super-channels in optical fibers [2], offering increasing performance and higher spectral efficiency [3]. Such coexistence is often referred to as elastic optical flexible-grid networking. This new paradigm permits to well adapt the channels' capacity to traffic demands, achieving a more effective use of the deployed bandwidth, leading to a reduction in required network resources and energy consumption.

To cope with elastic optical flexible-grid networks, optical nodes should be able to deal with variable bandwidth lightpaths¹ allocated in the optical spectrum in a flexible manner. In the recent literature, two main approaches have

been proposed for the design of future optical nodes: reconfigurable optical add/drop multiplexers (ROADMs) [4] and Architecture on Demand (AoD) node [5]. In this paper, we study the two architectures in a network context and compare their performance taking into account both spectral efficiency and energy consumption. We investigate several randomly generated network topologies, varying the number of nodes, the average node degree connectivities, and the average link lengths, to understand in which conditions, if any, one of the two architectures is more effective than the other one.

The remainder of the paper is organized as follows. In Sec. II the considered node architectures are described in detail. The network scenario and the adopted design tool are introduced in Sec. III. In Sec. IV results are reported and some concluding remarks are given in Sec. V.

II. OPTICAL NODE ARCHITECTURES

The ROADM and AoD node architectures have been proposed as the two most promising solutions for elastic flexible-grid networks. On the one hand, ROADMs has reconfiguration capabilities which are important in the elastic flexible-grid scenario, where switching requirements can be largely different from node to node. Indeed, part of the optical switching functionality can be managed by active optical devices allowing software-driven control, management and remote operability. Furthermore, ROADMs architecture notably evolved in the recent years. Several research studies focused on developing cost-effective solutions for colorless, directionless or contentionless (C/D/C) ROADMs [4], [6], [7]. The introduction of these characteristics enhances the role of ROADMs in elastic optical flexible-grid networks, compared with the first generations of ROADMs [8]. However, all the proposed ROADMs are based on a hard-wired connection of internal devices, which may still limit their flexibility.

On the other hand, the breakthrough optical node concept of AoD, introduced by *Amaya et al.* in 2011 [5], offers unprecedented levels of flexibility. AoD is based on an optical cross-connect that dynamically synthesizes architectures to provide the required functionality and fulfill traffic switching and processing requirements. AoD has been experimentally demonstrated in recent works including multi-domain switching [9] and software defined networking (SDN) [10]. Furthermore, AoD has been shown to provide considerable gains

¹We use the term lightpath to indicate a logical optical channel between two nodes as it is usually done in optical networking.

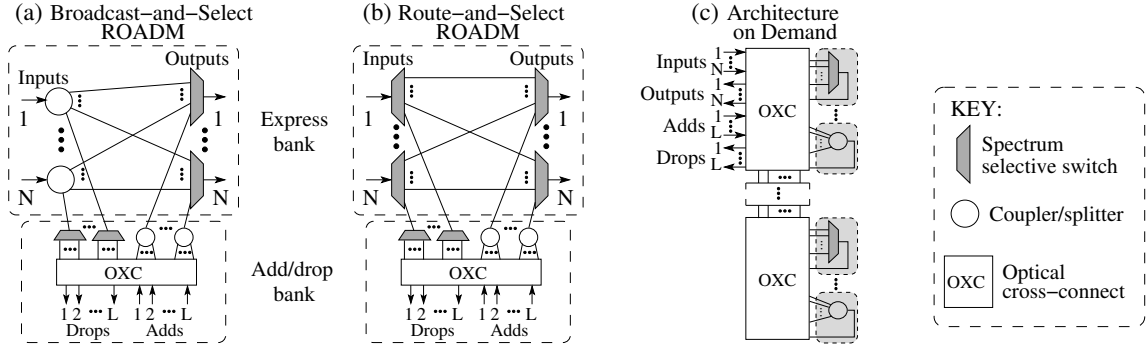

Fig. 1. Optical node architectures under analysis

in terms of scalability [11], power consumption [12] and resiliency [13]. However, these studies considered always a stand-alone single-node scenario. To the best of our knowledge no attempt has been made to evaluate AoD performance in a network scenario, as presented in this paper.

In our analysis, besides the AoD solution, two variants of ROADMs, namely Broadcast-and-Select (BS-) and Route-and-Select (RS-), are considered. To design the three architectures only three internal components are needed: coupler/splitter (C/S), spectrum selective switch (SSS) and optical cross connect (OXC).

A. Internal components characteristics

We assume that the C/S has an insertion loss in dB equal to $10\log_{10}(k)$, where k is the degree of coupling/splitting. The C/S is a fully passive device and therefore it does not contribute to the node power consumption.

The SSS is used to select the desired portion of spectrum, considering both the case of several inputs port and a single output port (multiplexing), or the case of a single input port to several output ports (demultiplexing). We assume to employ a 1×20 SSS, the port count of today commercially available wavelength selective switches [14]. The SSS has an insertion loss of $L_{SSS} = 7\text{dB}$ and a fixed power consumption of 25 Watt.

Finally, the selected OXC has a port count of 320×320 , presents an insertion loss of $L_{OXC} = 2\text{dB}$ and a power consumption of 50 Watt [15].

As a consequence, for any architecture, the power consumption of a given node can be computed simply by adding the contribution of the internal components:

$$P_{\text{arch}}[\text{W}] = \#SSS_{\text{arch}} \times 25 + \#OXC_{\text{arch}} \times 50 + 150 \quad (1)$$

where the constant term of 150 Watt takes into account the power consumption overhead (i.e., controller, cooling fans and power supply module).

B. ROADM architectures

The architecture of a ROADM can be decomposed into two banks: the express bank and the add/drop bank. The express bank interconnects input and output ports (namely inputs and outputs respectively) to provide connectivity from/towards

other ROADMs in the network. The add/drop bank provides the required connectivity between the express bank and the transmitters (receivers) for lightpaths with source (destination) at the local node. The insertion losses experienced by a lightpath traversing a ROADM depend on the route followed by the lightpath in the node. Three cases are possible: i) *express* losses, the lightpath is in transit and it just goes through the express bank, ii) *drop* losses, when the lightpath is dropped at the node, and iii) *add* losses, the lightpath is generated at the node and it is added to an output port.

1) *Broadcast-and-Select ROADM*: As shown in Fig. 1(a), the classical Broadcast-and-Select architecture (BS-ROADM) of degree N is implemented using N splitters connected in a full mesh to N SSSs which filter the undesired lightpaths at each output. Note that the losses introduced by the broadcast splitters increase linearly with N , which limits the scalability of this solution to a small degree.

The design of the add/drop bank is subject of various studies and it still represents a main challenge in the research community. Depending on the implementation, the ROADM may offer C/D/C capabilities. Dealing with cost-effective solutions to guarantee C/D/C features is outside the scope of this work. For the drop direction, we consider one SSS per input (that filters the dropped optical lightpath) followed by an OXC to provide connectivity towards the desired receiver. For the add direction, we consider the same OXC followed by a coupler so that several lightpaths can be added per output. This configuration is commonly used to provide C/D/C capabilities for both fixed- [6] and flexible-grid [7] ROADM node architectures.

Node dimensioning. A BS-ROADM, similar to the one shown in Fig. 1(a), contains a number of SSSs equal to

$$\#SSS_{\text{BS}} = 2 \cdot N \quad (2)$$

whereas the number of optical cross-connects (OXCs) is

$$\#OXC_{\text{BS}} = \lceil (\gamma_{\text{add}} + \gamma_{\text{drop}}) / 320 \rceil \quad (3)$$

being N the degree of the ROADM, γ_{drop} the number of lightpaths terminating at the node and γ_{add} the number of lightpaths starting at the node.

Node insertion losses. For the BS-ROADM, the express losses are

$$EL_{BS}[\text{dB}] = 10\log_{10}(N + 1) + L_{SSS} + L_{\text{conn}} \quad (4)$$

where the first term takes into account the loss due to a splitter of degree $N + 1$ (e.g., N connections to the outputs and one connection towards the add/drop bank), the second term adds the losses due to the SSS, and the third term takes into account overhead losses (i.e., fiber connections between the internal ROADM components).

The drop losses can be computed as

$$DL_{BS}[\text{dB}] = 10\log_{10}(N + 1) + L_{SSS} + L_{\text{OXC}} + L_{\text{conn}}. \quad (5)$$

Dropped lightpaths experience the same losses than express lightpaths plus the losses due to the OXC of the add/drop bank. The maximum number of lightpaths per input terminating (i.e. dropped) in a BS-ROADM node is limited to 20 due to the port count limit of the SSS. Thus, only one OXC is required until a node degree of 8, since a single OXC can host at most 160 dropped and 160 added lightpaths.

Similarly, the losses for an added lightpath are:

$$AL_{BS}[\text{dB}] = L_{\text{OXC}} + 10\log_{10}\left[\frac{\gamma_{\text{add-MAX}}}{(20 - N)}\right] + L_{SSS} + L_{\text{conn}} \quad (6)$$

where the first term is the OXC of the add/drop bank and the second term corresponds to the losses of the coupler that aggregates the added lightpaths towards each output.

We assume that $\gamma_{\text{add-MAX}}$, the maximum number of lightpaths that can be added per output, is equal to 20, equal to the maximum number of dropped lightpaths at a given input. The number at an input is constrained by the port count of the SSS, while at the output has been arbitrarily selected. However, the maximum number of added or dropped lightpaths per degree is estimated to be sufficiently large to avoid constraining the network design also for a medium-large sized network (e.g., from 20 to 40 nodes).

2) *Route-and-Select ROADM:* Fig. 1(b) shows a classical example of a Route-and-Select (RS-ROADM) architecture. The upper part shows the express bank of a RS-ROADM of degree N composed of two stages of N SSSs. The first stage of SSSs routes (i.e. switches and filters) the express lightpaths towards the outputs and the dropped lightpaths towards the add/drop bank. Lightpaths are then filtered again at the select stage of SSSs guaranteeing lower loss and higher isolation compared to the BS-ROADM [4], but at the cost of a higher energy consumption. We assume for the add/drop bank of the RS-ROADM the same structure as for the BS-ROADM.

Node dimensioning. The number of required SSSs to build a RS-ROADM is:

$$\#SSS_{RS} = 3 \cdot N \quad (7)$$

and the number of optical cross-connects (OXCs) is the same as $\#OXC_{BS}$.

Node insertion losses. Optical lightpaths bypassing a RS-ROADM as the one in Fig. 1(b) experience the following losses

$$EL_{RS}[\text{dB}] = 2 \cdot L_{SSS} + L_{\text{conn}} \quad (8)$$

Algorithm 1 SP: Synthesis procedure

For a lightpath g with input= g_{in} and output= g_{out}
if Set of lightpaths in g_{out} = Set of lightpaths in g_{in} **then**
 (a) Set (reuse) backplane cross-connection
else if Set of lightpaths in g_{out} = Union of “ g_{in} s” of different inputs **then**
 (b) Couple those input fibers towards g_{out}
else
 (c) Synthesize a BS-ROADM architecture
end if

due to the two SSSs stages [14] and to the overhead losses. Note that the express losses in RS-ROADMs do not increase with the degree size N , a clear advantage against BS-ROADMs.

Optical losses for optical lightpaths dropped in a RS-ROADM can be computed as

$$DL_{RS}[\text{dB}] = 2 \cdot L_{SSS} + L_{\text{OXC}} + L_{\text{conn}}. \quad (9)$$

which are the same as EL_{RS} plus the losses due to the OXC.

Optical losses for lightpaths added in a RS-ROADM are equal to the BS-ROADM case.

C. Architecture on Demand

The AoD node architecture, shown in Fig. 1(c), consists of an optical backplane that interconnects inputs, outputs, adds, drops ports, and AoD modules (e.g. coupler/splitter, SSS). AoD, unlike the previously described ROADMs, devises and synthesizes architectures suited to the switching requirements of the input lightpaths. Specific architectures are then constructed by interconnecting, in a suitable way, the building modules using backplane cross-connections. The optical backplane can be implemented with a 3D-MEMS optical switch or beam-steering switch [16] having just 0.5 dB insertion loss. In this work we assume that the backplane cross-connection has an insertion loss of $L_{\text{OXC}} = 2\text{dB}$ which also includes the overhead losses, similarly to the ROADMs case. Note that AoD can support many functionalities depending on its building modules. For instance, it is possible to synthesize architectures that include: optical amplification, time-domain switching, wavelength conversion, etc. [17]. However, in this work we consider architectures that only perform spectrum switching.

1) *AoD synthesis:* A synthesis procedure (SP) has been developed to construct specific architectures. This procedure, shown in Algorithm 1, has been firstly introduced in [11]. The SP can construct three types of AoD instances depending on the lightpaths present at the inputs and at the outputs: **(a)** if the lightpaths’ set of a given input corresponds to the lightpaths’ set of a given output, then a simple backplane cross-connection is set between those input and output ports; **(b)** if the lightpaths’ set of a given output is the union of lightpaths’ sets of two or more given inputs, then those inputs need to be coupled; and **(c)** if cases (a) and (b) are not applicable, (i.e. the lightpaths’ set of a given output is

the intersection of lightpaths' sets of two or more given inputs) AoD synthesizes a BS-ROADM architecture among the involved inputs and the selected output. Finally, we consider the same procedure if added or dropped signals are involved in the synthesized architecture.

To illustrate the AoD synthesis, Fig. 2 shows in the upper part three different AoD instances for three different sets of lightpaths bypassing the node (added and dropped lightpaths are not considered in these examples). Furthermore, the lower part of Fig. 2 shows how those instances are obtained by means of cross-connections in the optical backplane. In particular, three different synthesized architectures illustrate the SP outputs (a), (b) and (c) respectively. Note that the number of backplane cross-connections is 2, 3 and 8 for (a), (b) and (c) respectively. For numbers of backplane cross-connections lower than 320, a single OXC is enough.

2) *Node dimensioning*: The number of SSSs and OXCs required in the AoD strictly depends on the synthesized architecture and can be computed using the SP described in Algorithm 1.

3) *Node insertion losses*: Lightpaths traversing an AoD node suffer different losses depending on their path, similarly to the ROADMs, but also, on the specific synthesized AoD. Let's start considering the express lightpaths losses. For the case (a):

$$EL_{\text{AoD-(a)}}[\text{dB}] = L_{\text{OXC}} \quad (10)$$

because a single backplane cross-connection is required. For case (b), losses can be computed as

$$EL_{\text{AoD-(b)}}[\text{dB}] = 2 \cdot L_{\text{OXC}} + 10\log_{10}(m) \quad (11)$$

because two backplane cross-connections and a coupler are used, where m is the number of inputs providing lightpaths to the output fiber. In the last case (c), losses are

$$EL_{\text{AoD-(c)}}[\text{dB}] = 3 \cdot L_{\text{OXC}} + L_{\text{SSS}} + 10\log_{10}(k) \quad (12)$$

as in the BS-ROADM (that includes three backplane cross-connections, a SSS and a splitter), where k denotes the number of outputs towards which lightpaths from input must be routed.

The SP can be similarly applied to dropped and added lightpaths. Thus, insertion losses for dropped lightpaths can be either equal to $EL_{\text{AoD-(a)}}$, in the case (a), that means that at the input there are just lightpaths to be dropped, or

$$DL_{\text{AoD-(c)}}[\text{dB}] = 3 \cdot L_{\text{OXC}} + 10\log_{10}(K) + L_{\text{SSS}} \quad (13)$$

for case (c). In case (b) it is not possible to drop lightpaths.

Regarding losses for added lightpaths, they can be either equal to $EL_{\text{AoD-(a)}}$, if it corresponds to the case (a) of the SP, or $EL_{\text{AoD-(b)}}$, in case (b) of the SP, otherwise losses can be computed as

$$AL_{\text{AoD-(c)}}[\text{dB}] = 2 \cdot L_{\text{OXC}} + L_{\text{SSS}} \quad (14)$$

which corresponds to two backplane cross-connections and a SSS.

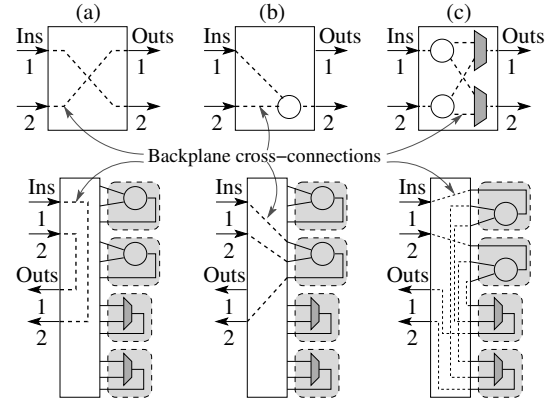

Fig. 2. AoD synthesis examples

TABLE I
DETAILS OF THE AVAILABLE MODULATION FORMATS

Modulation Level	BPSK	QPSK	8QAM	16QAM	32QAM	64QAM
Transmission Rate [Gb/s]	12.5	25	37.5	50	62.5	75
Optical Reach [km]	4000	2000	1000	500	250	125

III. NETWORK SCENARIO AND DESIGN

A. Network scenario

The selected scenario is an IP over elastic flexible-grid network. Traffic demands are sent from sources to destinations using lightpaths. IP routers are used to perform electronic switching of the traffic demands between two lightpaths if it is required. Each lightpath is generated at the source node and terminated at the destination node by a flexible Orthogonal Frequency Division Multiplexing (OFDM) transponder which can employ one of the available modulations listed in Table I. The maximum bit-rate of a single spectrum slot and the maximum transmission reach for every modulation format are indicated. We assume that the transponder has a maximum bit-rate capacity equal to 400 Gb/s. We consider to employ on each fiber link the whole C-band (4 THz) and to divide it in 320 spectrum slots of size 12.5 GHz. It is also assumed that two empty slots are left as guard-band between two lightpaths. This scenario has been taken from [18].

1) *Power consumption model*: The contributions to the network power consumption are given by the IP routers, the flexible OFDM transponders, the optical switching nodes (i.e., ROADMs or AoD) and the optical line amplifiers (OLAs) installed in the physical links. The power consumption of the different optical node architectures is described in Sec. II-A. Different configurations of IP routers are available, each configuration having a given switching capacity. We compute the power consumption of an IP router as a function of its capacity using a constant value of 10 W/Gb/s as indicated in [19]. The power consumption of OFDM transponders and OLAs has been computed using the model introduced in [20].

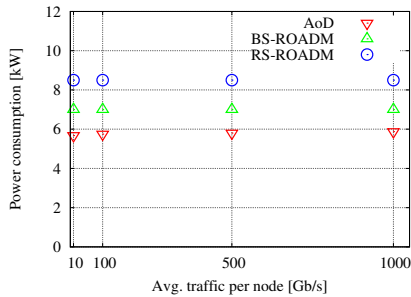

(a) Power consumption of the optical nodes.

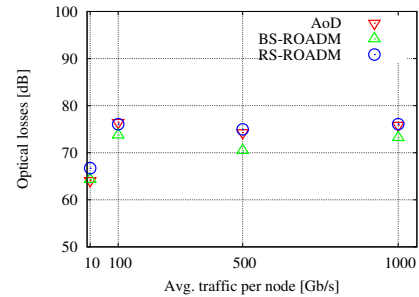

(b) Average losses per lightpath.

Fig. 3. Results for a 20 nodes network with average node degree connectivity of 2 and average link length of 500 km.

B. Network design

The network design has been solved using the IP-Grooming Heuristic (IGH), introduced in [21]. IGH is an energy-aware greedy heuristic which determines the lightpaths to be established in an elastic flexible-grid network to support given traffic requirements. In the following, a summary of the heuristic is given; a detailed description can be found in [21].

The IGH iteratively satisfies traffic demands choosing the less energy consuming alternative between establishing a new direct lightpath from the source to the destination or using a sequence of already established lightpaths, if enough capacity is available on all the lightpaths of the sequence. This capacity can be obtained by the heuristic changing the modulation format or increasing the number of used spectrum slots in already established lightpaths.

A modulation format is used in each lightpath depending on the required capacity. Constraint in the choice of the modulation format is the optical signal to noise ratio (OSNR) of the lightpath's signal at the destination node. Indeed, each modulation format requires a minimum level of OSNR, otherwise the signal can not be received correctly. The OSNR reduction is due to the noise introduced by the OLAs, the only active optical devices present at the physical layer. The OLAs are placed to compensate for the optical losses experienced by the lightpaths. Since only propagation losses of the optical fibers are considered, the minimum OSNR is usually translated into a maximum transmission reach, as reported in Table I.

In this work, we take into account also the losses introduced by the optical nodes that a lightpath is traversing. We consider the losses to be translated into equivalent fiber length, considering a propagation loss of the fiber equal to 0.2 dB/km. The maximum transmission reach limit for a given lightpath is thus checked considering the length of its physical path and the fictitious length of the optical nodes. In future works, we will focus on performing the computation of the OSNR value at the destination node of each lightpath using exact formulas.

IV. RESULTS

The different architectures have been compared considering different number of network nodes, traffic loads, average node degree connectivities, and average link lengths.

The traffic load is varied changing the average traffic per node. Traffic matrices are randomly generated so that the average traffic per node is equal to 10, 100, 500 or 1000 Gb/s. We consider networks from 20 to 40 nodes, the average node degree connectivity is within the range [3,6] and the average link lengths are ranging from 125 km up to 1000 km.

The power consumption of the optical nodes for different traffic scenarios is shown in Fig. 3(a). The reported results refer to a 20 nodes network scenario with average node degree connectivity of 2 and average link length of 500 km. The AoD nodes are the less consuming, followed by BS-ROADM and then by RS-ROADM nodes. These results indicate that AoD nodes are effectively synthesized according to the actual switching requirements. A reduction of the components used in each node is then possible with respect to the static architectures of ROADMs, achieving a decrease in the power consumption. The RS-ROADM architecture results to be the highest power consuming due to the double stage of SSSs.

The total power consumption of the network, considering the three architectures, is scarcely different: In the AoD case, the power consumption is lower of about 2-3% with respect to ROADM architectures. Indeed, the deployment of electronic devices, such as IP routers and OFDM transponders, is not influenced by the different architectures of the optical nodes, and their large consumption dominates the total network power consumption.

Furthermore, the three node architectures are equivalent from the spectral efficiency point of view, i.e. the average number of spectral slots used per fiber link is similar.

The average optical losses that a lightpath experiences as a function of the traffic load are reported in Fig. 3(b). The losses for the case of AoD are not the lowest, being in BS-ROADM case the lowest. Indeed, the losses introduced by the couplers at low degree connectivities are lower in comparison to the losses of the SSSs. However, the experienced losses present small differences for the three architectures.

The impact of the node degree connectivity is shown in Fig. 4(a). The network scenarios correspond to a 20 nodes network with average link length of 500 km and average traffic per node equal to 100 Gb/s. The power consumption related to the optical nodes increases with the node degree. In particular, for the two ROADMs architectures the increase

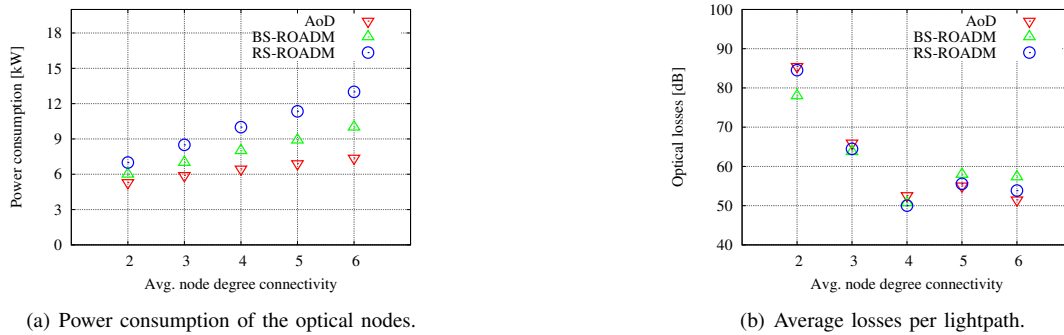

Fig. 4. Results for a 20 nodes network with average link length of 500 km and average traffic per node equal to 100 Gb/s.

is larger because the number of components in a node is directly proportional to the number of fibers connected to the node, which is not the case for the AoD. Furthermore, for high degree connectivity, the number of SP outputs (i.e. AoD synthesized architectures) corresponding to (a) and (b) increases. Therefore, the power consumption of AoD increases at a lower pace compared with those of ROADMs. The average optical losses per lightpath instead diminish with the increase of the node degree, as shown in Fig. 4(b). Indeed, lightpaths on average have to perform a smaller number of hops before reaching destinations. Thus, the losses experienced when bypassing the nodes are significantly reduced. However, for node degrees equal or larger than 4, this benefit vanishes because lightpaths can not further decrease the number of hops. Notice that in the BS-ROADM architecture lightpaths experience on average larger losses for degree 5 and 6 because the losses due to the couplers become larger than SSSs' losses.

Finally, networks with different average link lengths have been examined: the link length parameter has the same impact on the three architecture and no general trends can be easily identified. Similar trends are observed when increasing the number of nodes in the network.

V. CONCLUSIONS

Two different ROADM and AoD architectures of optical nodes were analyzed and their loss models were introduced. Network scenarios considering different traffic loads, average link lengths and average node degrees were compared considering power consumption and spectral efficiency.

The power consumption of AoD nodes results to be the lowest, although the difference among architectures is not major. Losses experienced by lightpaths are similar regardless of the node architecture. AoD does not always present the lowest losses because the network design phase optimizes the power consumption. AoD performs slightly better because it tailors the node architecture to the specific traffic scenario.

ACKNOWLEDGMENTS

This work is supported by FUNTTEL, FINEP and CPqD Foundation under the project 100GETH.

REFERENCES

- [1] <http://www.itu.int/rec/T-REC-G.694.1-201202-I/en>
- [2] O.Gerstel, M.Jinno, A.Lord, and S.J.B.Yoo, "Elastic optical networking: A new dawn for the optical layer?", *IEEE Communications Magazine*, **50**(2), pp.12–20, 2012.
- [3] C.Politi, C.Matrakidis, T.Orphanoudakis, V.Anagnostopoulos, and A.Stavdas, "Planning and operation of elastic flexgrid optical networks with OFDM variable bandwidth capabilities", *ICTON 2013*.
- [4] R.Younce, J.Larikova, and Y.Wang, "Engineering 400G for colorless-directionless-contentionless architecture in metro/regional networks [invited]", *JOCN*, vol.5, no.10, pp.A267–A273, Oct. 2013.
- [5] N.Amaya, G.S.Zervas, and D.Simeonidou, "Architecture on demand for transparent optical networks", *ICTON 2011*.
- [6] R.Jensen, A.Lord, N.Parsons, "Colourless, directionless, contentionless ROADM architecture using low-loss optical switches", *ECOC 2010*.
- [7] W.Way, "Optimum architecture for M×N multicast switch-based colorless, directionless, contentionless, and flexible-grid ROADM", *OFC 2012*.
- [8] J.Berthold, A.Saleh, L.Blair, and J.Simmons, "Optical networking: past, present, and future", *JLT*, vol.26, no.9, pp.1104–1118, May 2008.
- [9] N.Amaya, et al., "Fully-elastic multi-granular network with space/frequency/time switching using multi-core fibres and programmable optical nodes", *Optics Express*, vol.21, Issue 7, pp.8865–8872, 2013.
- [10] N.Amaya, et al., "First Demonstration of Software Defined Networking over Space Division Multiplexing Optical Networks", *ECOC 2013*.
- [11] M.Garrich, N.Amaya, G.S.Zervas, P.Giaccone, and D.Simeonidou, "Architecture on demand: Synthesis and scalability", *ONDM 2012*.
- [12] M.Garrich, N.Amaya, G.S.Zervas, P.Giaccone, and D.Simeonidou, "Power Consumption Analysis of Architecture on Demand", *ECOC 2012*.
- [13] M.Dzanko, B.Mikac, N.Amaya, G.S.Zervas, and D.Simeonidou, "Availability analysis of optical cross-connect implemented by architecture on demand", in *ICTON 2012*.
- [14] <http://www.finisar.com/products/wss-roadms>
- [15] <http://www.calient.net/products/s-series-photonics-switch/>
- [16] T.A.Truec, A.A.Bent, N.W.Hagood, "Beam-steering optical switch fabric utilizing piezoelectric actuation technology", *NFOEC 2003*.
- [17] N.Amaya, et al., "Gridless optical networking field trial: Flexible spectrum switching, defragmentation and transport of 10G/40G/100G/555G over 620-km field fiber", *Optics Express*, pp.B277B282, 2011.
- [18] J.Vizcano, Y.Ye, and I.Monroy, "Energy efficiency analysis for flexible-grid OFDM-based optical networks" *Computer Networks*, vol.56, Issue 10, pp.2400–2419, 2012.
- [19] W.Van Heddeghem, F.Idzikowski, W.Vereecken, D.Colle, M.Pickavet, and P.Demeester, "Power consumption modeling in optical multilayer networks" *Photonic Network Comm.*, vol.24, no.2, pp.86–102, 2012.
- [20] J.Vizcano, Y.Ye, V.López, F.Jiménez, R.Duque, and P.Krummrich, "On the Energy Efficiency of Survivable Optical Transport Networks with Flexible-grid" *ECOC 2012*.
- [21] A.Ahmad, A.Bianco, E.Bonetto, "Traffic grooming and energy-efficiency in flexible-grid networks", *ICC 2014*.