

Chapter 5

Inverters for grid connection of photovoltaic systems and power quality: case studies

This chapter deals with the performance of grid-connected inverters for Photovoltaic (PV) systems and their power quality fed into the grid. The contents of this chapter are extracted from the paper [56]. After an introduction to the new regulations for smart grid connection in presence of Distributed Generators (DG) in Italy, published in [57], the study concentrates the attention on a variety of power inverters both in normal and in unusual operation. The Power Quality (PQ) issues are assessed from an experimental point of view. In particular the PQ problems in case of shading effect on the PV modules are highlighted, considering the main case study of this dissertation: array no. 5 of the BIPV system introduced in section 4.3. The corresponding increase of harmonic content and unbalance, together with the decrease of power factor, is assessed in the chapter.

5.1 Introductory framework

With the development of the Renewable Energy Sources (RES), the Power Quality (PQ) and grid stability issues are becoming more and more important, due to the intrinsic fluctuations of their power injection. The national Standards pro-

vide specifications in regards to the grid codes: [58] is a common reference for PQ in Europe. These ones concern RMS voltage and frequency variations (both slow and rapid), voltage dips, harmonic content of voltage and current signals, unbalance of the three-phase systems, flicker disturbances (both short and long term), etc.. About the grid stability, Germany leads the race for the application of the suitable requirements with a norm already operating. A new Italian standard [59] was issued at the end of 2011, in its first issue, and the regulations became mandatory in the 2012. The main news deal with the ancillary services that the power electronic converters (usually inverters) have to provide to the grid. In particular, when the voltage dip occurs, the inverters must continue to operate without active power injection if the voltage dip is not too long. In phase of voltage recovery towards the rated value after the complete solving of the fault, the inverters must provide an amount of reactive power to magnetizing the electric machines connected to the local grid. By contrast, in the past, with low penetration of RES plants, when the voltage dip occurred, the inverters were switched off and restarted the operation only at normal conditions. With reference to PV systems, in [60] some regulations about harmonic content provide limits referred to the Total Harmonic Distortion (THD) of voltage and current. These limits are defined at the rated power of the devices, but, when the devices operate at low power levels, THD indexes increase considerably. In general, if the power rating of the inverter is not negligible with respect to the short circuit power of the grid, the harmonic content in the current injected into the grid can have an impact on the harmonic content of the grid voltage. Below a given limit of harmonic content in current (e.g. $THD_I = 5\%$), its influence on harmonic voltage is negligible, whatever is the rated power of inverter. The active/reactive power control performs the task of unitary power factor within the range 20–100% of rated power; in this interval the electronic converter compensates for the reactive power demand of the grid interface stage. Below this threshold (20–30% of nominal AC power) the reactive power demand and the harmonic distortion determine the power factor's decrease and the increase of THD_I , due to the prevailing capacitive behaviour on the grid interface stage. In the following, at first the forthcoming rules for the PV system inverter connection to the LV grid in Europe are presented, taking inspiration from the new Italian standard. In the

following the fulfilment of the grid connection requirements during normal operation conditions is verified for a small residential PV system with a mono-phase 3 kVA inverter and for a three-phase 230 kVA inverter, part of a large 2 MW_p PV plant. The PQ analysis of the two inverters is illustrated, taking into account some PQ issues, such as the harmonic content of voltage and current signals, the unbalance of the three-phase system and the power factor control [16, 61]. Therefore, for comparison, the case-study of section 4.3 (large industrial BIPV plant) is presented, taking into account one of the 100 kVA three-phase inverters. Here, the attention is focused on the PQ consequences of partial shading of the BIPV array, in terms of three-phase unbalance, harmonics and power factor.

5.2 Italian Grid Codes for HV and LV interconnections

In this section the Italian grid code for the connection of active and passive users to the utility network, both High Voltage (HV) and Low Voltage (LV), is exposed. According to the Italian Electrotechnical Committee (Comitato Elettrotecnico Italiano — CEI), the active users are connected to the grid to produce energy and may contain any machine, static or rotating, that operates the conversion from a given form of useful energy into electricity, while the passive users are the users connected to the LV network that do not fall into the previous definition of active users. The evolution of the regulations has followed that of the typology and diffusion of the Distributed Generation (DG). The constant increasing of the DG penetration has forced the various authorities to modify the connection rules after a period without changes. When the first electricity self-producers appeared, the distributors were the first to elaborate their own technical rules for the connection of the local resources to their grids, in order to preserve their safety and stability. The local producers were allowed to be connected to the utility grid with the obligation to disconnect from the network as fast as possible when the RMS voltage was falling outside the normal operational range. One of the first international standards concerning the distributed resources was the IEEE Standard 1547 [62], which stated that for an RMS voltage lower than

50% of the rated voltage V_n the distributed resource shall cease to energize the power system within 160 ms, while for an RMS voltage in the range from 50% to 88% of V_n the interruption shall be within 2 s. Similar conditions were applied for voltages higher than the rated voltage (i.e., system disconnection within 1 s for RMS voltage higher than 110% V_n and within 160 ms for RMS voltage higher than 120% V_n). Since the total amount of DG was relatively low the effect of disconnecting all the distributed resources was practically not disturbing the quality of supply in a significant way, but when the diffusion of DG in the distribution networks increased as well did its impact on the distribution and transmission network. In normal conditions the presence of some local producers, equipped with controlled interfaces aimed at maintaining the power factor close to unity and at reducing the harmonic distortion of the injected currents, has been beneficial for the distribution system operation [63]. However, in the presence of a significant amount of distributed generation, after a fault occurs the switch-off of the whole local generation would be seen by the distribution network as a steep variation in the generation power at constant load, and by the transmission network as a lack of electricity production at its nodes.

The need for maintaining network stability and security within acceptable ranges has pushed the Transmission System Operators (TSOs) towards issuing a set of recommendations. In particular, on 18 June 2011 the European Network of the Transmission System Operators (ENTSO-E) has remarked that an increase of local generation could lead to a critical situation for national system security and that the national standards needed to be modified, also by issuing national plans for re-programming or retrofitting the existing plants.

In Italy the process of setting and updating the national standards and codes involved various subjects. The regulatory agency is the Authority for Electrical Energy and Gas ¹, while the national TSO is TERNA, who elaborated the grid code [64] in force since 1 November 2005. This code is composed of a main text and a number of annexes. The CEI, instead, is responsible for issuing the standards on electrical components and plants. The CEI has made a specific rulemaking concerning the connection of local generation resources to the grid, starting from the Standard CEI 11-20 (first edition in 2000), containing rules

¹<http://www.autorita.energia.it>

for self-producers, with successive updates referring to the backup generation to supply the load in emergency conditions. The Standard CEI 11-20 introduced the conceptual partitioning of the local portion of the electrical system into three sections, separated by protection devices, as follows:

1. the local generation section, interfaced with the system through the generator protection device;
2. the portion of the local network enabled to remain connected to the local generator (in islanding operation) if a fault in the external distribution network occurs, interfaced with the system through the interface protection device;
3. the portion of the local network that can be no supplied if a fault in the external distribution network occurs, interfaced with the system through the general protection device.

Concerning the grid connection of local resources, in Italy the first rules appeared in the form of Directives issued by ENEL as the largest private electricity distribution company, once public and only one. These rules were based on setting up the requirements a local system had to meet in order to enable its connection to the grid. These rules then evolved by extending the discussions at the CEI level, resulting in issuing the CEI Standard 0-16 [65] (February 2008) referring to the connections to High Voltage (HV) and Medium Voltage (MV) systems. On March 30, 2008 the AEEG issued the Deliberation ARG/ELT 33/08 [66]. The second edition of the Standard CEI 0-16 was then updated and issued with the date of July 2008. After a few years, this document is currently under revision by CEI.

Referring the connections to the Low Voltage (LV) network, in December 2011, the CEI issued the Standard CEI 0-21 [59] to complete the coverage of the distribution systems by including the LV systems. On March 2012, TERNA and AEEG issued a set of documents in response to the ENTSO-E recommendations. The AEEG Deliberation 84/2012/R/EEL [67], appeared on 8 March 2012, defines the scheduling and the actuation rules of the Annexes to the grid code and of the Standards CEI 0-16 and CEI 0-21. This deliberation refers to the electricity

production plants connected to the MV network with power higher than 50 kW in operation at March 31, 2012, and the electricity production plants that will be connected to the MV and LV grids after April 1, 2012. On 13 March 2012, in actuation of the AEEG Deliberation 84/2012/R/EEL, three new annexes to the grid code were published: the annex A68 (PV production plants — Minimal requirements for the connection and the operation in parallel with the High Voltage grid); annex A69 (Connection criteria of the production plants to the defence system of TERNNA); annex A70 (Technical rules of the system requirements for distributed generation) [68]. In particular, the annex A70 indicates the ranges of operation of the grid-connected production plants, stating that “all the plants and the related machinery and devices have to be designed, constructed and operated in order to remain in parallel [with the grid] also in conditions of emergency and network restoration”. On 1 July 2012, the CEI issued the second edition of the Standard CEI 0-21, incorporating the changes required in the latest regulatory documents.

The present evolution is moving towards establishing plans for setting up pre-scheduled services, in order to reduce the effects of uncertainty in the electricity provision from non-programmable local generation sources. For this purpose, on August 2012 two new annexes to the grid code were issued, namely, annex A71 (Application rules for settlement in case of modification of the distribution network property) and A72 (Procedure for the reduction of distributed generation in emergency conditions of the National Electrical System) [69], continuing the process of upgrading the networks. The annex A72 has introduced the concept of Reducible Distributed Generation (RDG), associated to generation plants having all the following characteristics: plants of at least 100 kW size, connected to the MV network, supplied by non-programmable wind or photovoltaic sources, that inject in the grid their entire production (net of the auxiliary services). RDG is partitioned into remote controlled (RDG connected with dedicated lines, that can be switched off by the distributor upon specific requirement by TERNNA) and switchable with pre-notification (RDG connected with non-dedicated lines in which there are also customer plants, that can be switched off by the plant owner). For the remote-controlled RDG the control centre of TERNNA communicates to

the Distributor the need of cutting the RDG off, indicating the dedicated lines to be switched off and the corresponding time interval for the reduction. For the switchable RDG, seven days before the target day TERNNA communicates the need of cutting off the production from RDG, indicating the list of the groups to be cut, the day and hour, and the severity level (order of the groups to be cut off). The communication is valid if it is not withdrawn up to two days before the target date. The Distributor informs the RDG owner, that must switch off its production as required (avoiding to incur in penalties). In the following paragraph the ancillary services fixed by the Italian grid codes are detailed.

5.2.1 Frequency control

Frequency is the network parameter subject to the stricter limitations in its variation around the rated value (50 Hz). The main issues referring to frequency deal with the behaviour of the energy production plants during the frequency transients, the reconnection and active power control in function of the frequency, and the start-up and gradual increase of the power injected in the grid. In the foreword to the AEEG Deliberation 84/2012/R/EEL, it is indicated that for the photovoltaic plants the existing connection standards required their instantaneous disconnection from the grid for frequency variations above 0.2–0.3 Hz, and it is stated that the interface protection systems and the inverters have to become less sensitive to the frequency variation, in order to remain connected to the grid also for frequency variations between 47.5 Hz and 51.5 Hz.

The technical regulation admits restricted thresholds and permissive ones both for voltage and frequency (Fig. 5.1), in order to taking into account the system and the local disturbances. In case of system disturbance a large section of the grid is affected and the frequency could change very slowly, while the phase voltages conserve a symmetrical behaviour, therefore only the permissive thresholds are activated. While in case of local phenomena, such as faults or a relay opening, the DSO or a local device should enable the restricted thresholds to promote the system disconnection from the network. In particular, the new requirements ask for detecting a local phase-to-ground, or phase-to-phase or three-phase fault measuring the positive- (V^+), negative- (V^-) and zero-sequence (V^0) voltage

components, computed through the decomposition of the steady-state voltage phasors of the three-phase system (the method of symmetrical components [70]), and comparing them with a threshold set.

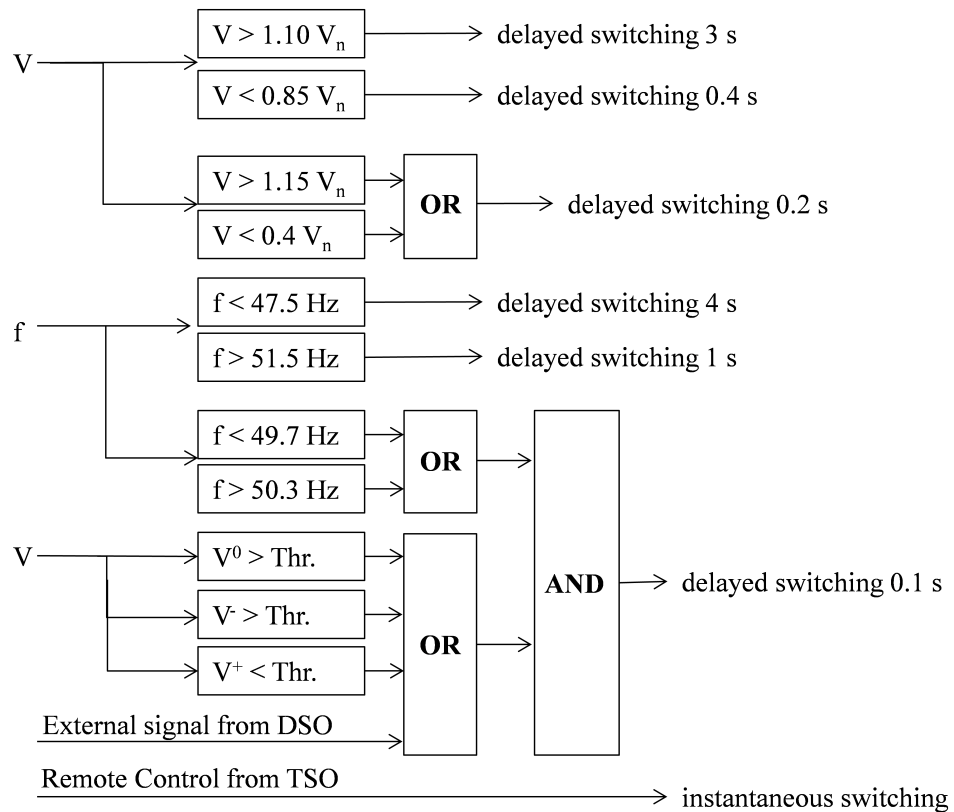

Figure 5.1: Control logic of the local interface protection system for MV systems.

5.2.2 Voltage stability and LVRT capability

In order to avoid voltage problems, the generation plants have to remain permanently connected to the Medium Voltage and Low Voltage networks, in any loading condition, when the voltage in the connection point falls within the interval from 85% to 110% of the rated voltage V_n (normal operation range). The active user shall guarantee that these operating intervals are respected by both the interface protection and the production plant controls. Active and reactive power have to be restored within 200 ms after the generator reaches the normal

operation range. The distributor verifies that these requirements are fulfilled. At the start-up the voltage interval is a little bit different and it goes from 90% to 110% of the rated voltage. The connection of the generator to the MV grid is allowed after a minimum time period of 300 seconds, in which the voltage must remain within the specified range, if the active user is disconnected for interface protection device's intervention, otherwise the minimum time period is reduced to 30 seconds.

In order to avoid losing the distributed resources due to faults in the network that cause voltage reductions in some areas, the generation plant shall remain connected to the network according to a predefined voltage-duration curve representing the Under Voltage Fault Ride Through (UVFRT) capability, as illustrated in Fig. 5.2 for the LV grid and in Fig. 5.3 for the MV grid. In Fig. 5.3, over the UVFRT curve it is represented the Over Voltage Fault Ride Through (OVFRT) one, which describes the static generator behaviour in case of over-voltage, such as when the faults in the network are cleared and switches are closed.

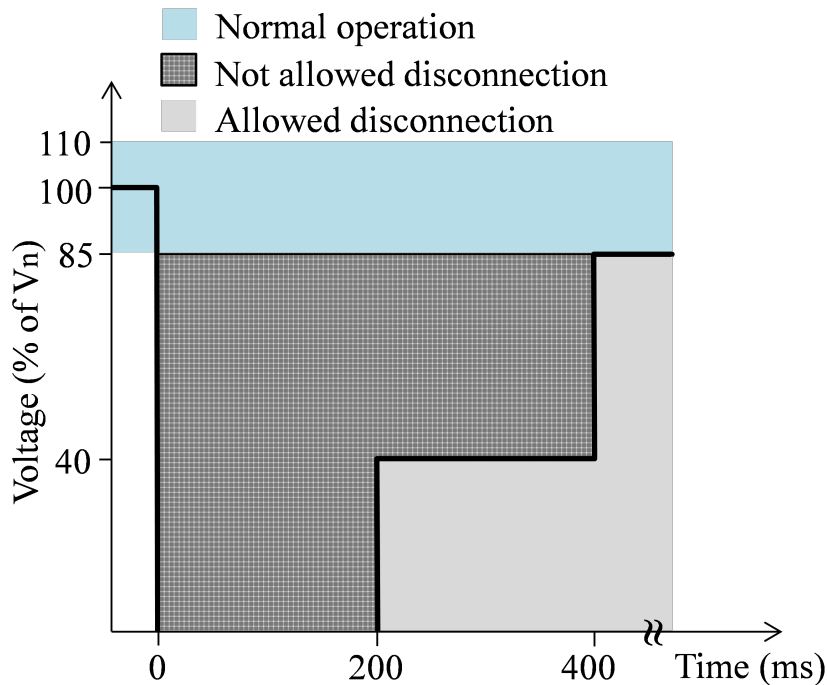

Figure 5.2: Reactive power capability ($S_n < 400$ kW).

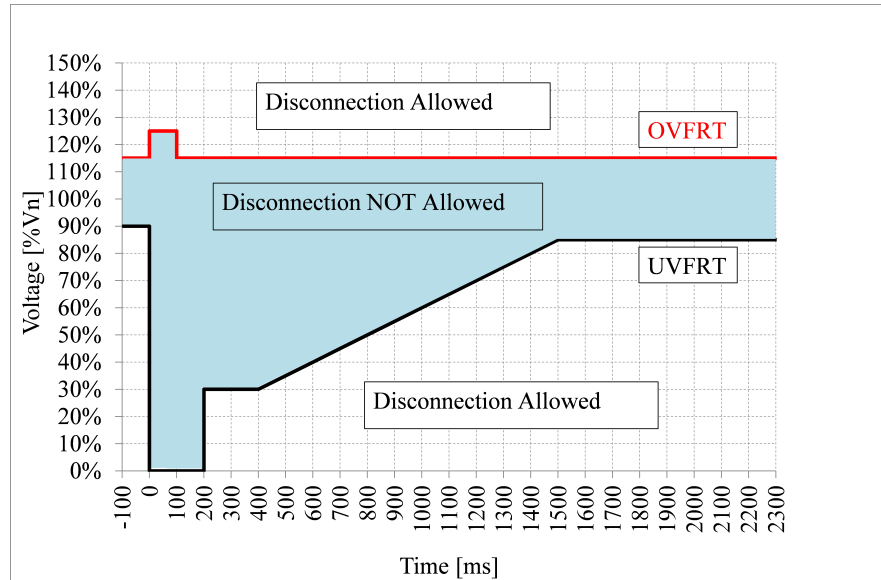

Figure 5.3: Reactive power capability ($S_n \geq 400$ kW).

5.2.3 Reactive Power capability

The capability curves of the generators are defined with reference to the apparent rated power S_n . The new technical rules for the MV (and HV) grid connection of static converters fix the requested capability of reactive power generation depending on the maximum active power in normal operating condition (rated voltage and unitary power factor):

- for rated power lower than 400 kW the reactive power capability is limited as shown in Fig. 5.4, with power factor constrained between 0.9 inductive and 0.9 capacitive;
- for rated power equal or higher than 400 kW the reactive power capability limits are semi-circular, as shown in Fig. 5.5.

The recent technical rules state that the distributed generators should participate at the grid voltage control. Obviously, when the voltage at common coupling point is higher than the rated value, the electronic converter must absorb inductive power, while when it is lower the converter must generate capacitive

power. In particular, the static converters have to provide an automatic (locally controlled) reactive power absorption according to the curve in Fig. 5.6, where P_n is the active power rating. This kind of control is activated when the voltage exceeds the lock-in value, defined by the grid operator in the interval $V_n \div 1.1 V_n$ ($1.05 V_n$ by default). As soon as the active power decreases under $0.5 P_n$ or the voltage reaches the lock-out value ($0.9 V_n \div V_n$, with V_n by default), the control is deactivated.

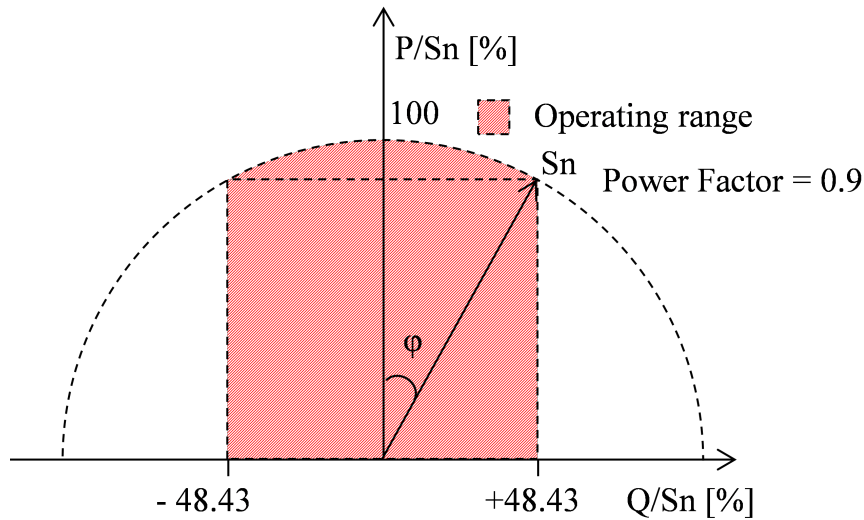

Figure 5.4: Reactive power capability ($S_n < 400$ kW).

Moreover, all the generators with reactive power capability like the one in Fig. 5.4 must absorb or generate reactive power according to the local control described in Fig. 5.7, which is a function of the voltage value in the common coupling point. This can be considered an ancillary service provided by the active user to the grid operator, so it has to be requested by the DSO when the operating rules are defined. At present, some regulations issued by the AEEG are expected for the activation of such a service. By denoting the rated active power with P_n , the control parameters are the lock-in active power of $0.2 P_n$ default value, and the voltage V_{1s} , V_{2s} , V_{1i} and V_{2i} set-points, which should be fixed within the $0.9 \div 1.1 V_n$ range, with a $0.01 V_n$ resolution.

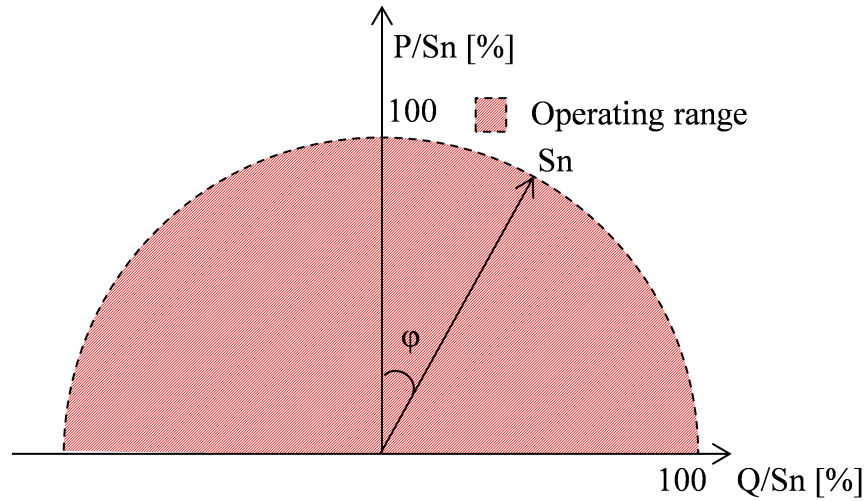

Figure 5.5: Reactive power capability ($S_n \geq 400$ kW).

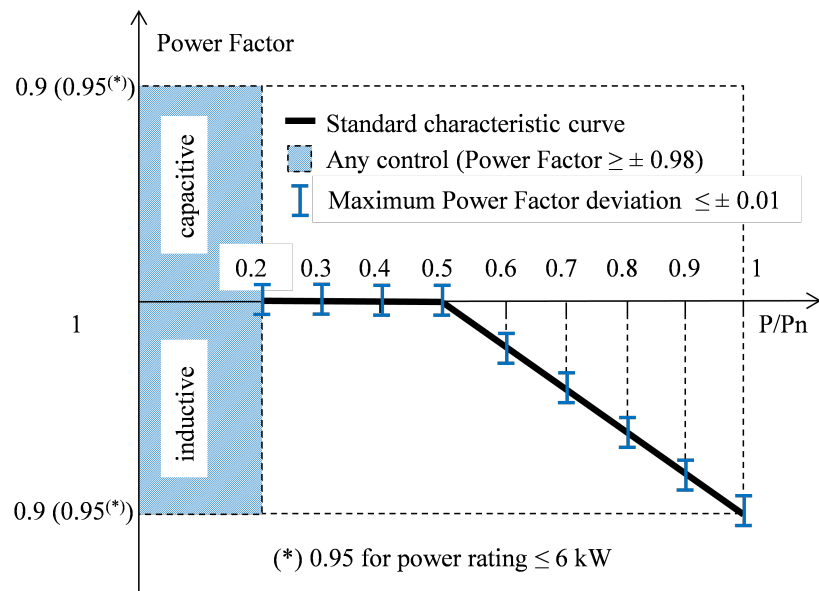

Figure 5.6: Reactive power control with power factor represented in function of P/P_n .

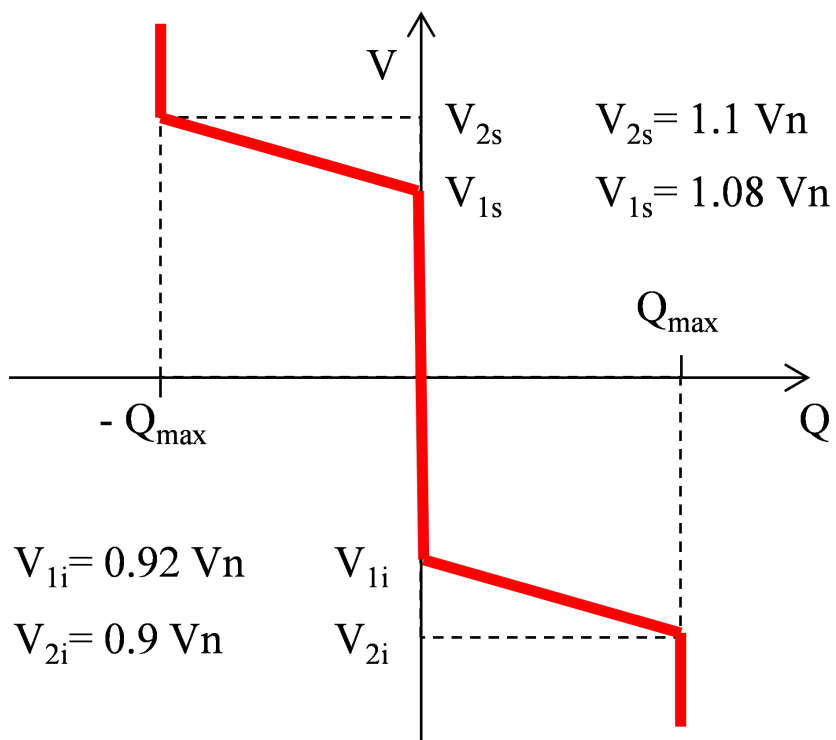

Figure 5.7: Reactive power control according to $Q = f(V)$.

5.2.4 Active Power control

In order to avoid disconnection of the distributed generator from the network when the voltage at the point of common coupling increases above the $1.1 V_n$ threshold, a local control shall limit the active power. This limitation is also activated in case of over-frequency, when it overcomes the 50.3 Hz value, according to the curve in Fig. 5.8. The static generator should decrease the output active power of an amount dependent on the over-frequency and the slope of the control curve, within a 2 seconds time period. After the over-frequency transient, when the value comes back to 50 ± 0.1 Hz for at least 300 seconds, the generator can increase the output power gradually, according to a fixed gradient, avoiding abrupt steps.

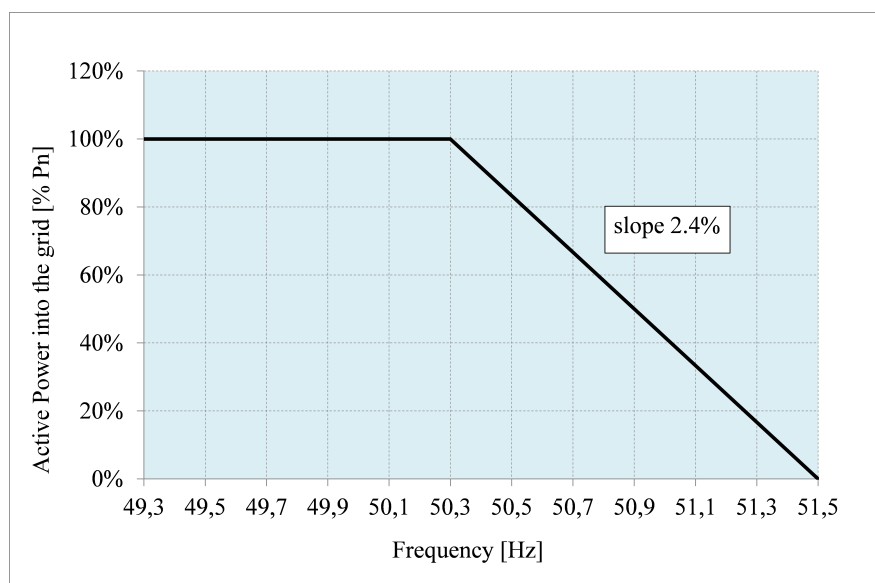

Figure 5.8: Active power control in case of over-frequency.

5.3 Methodology of the inverter analysis

Before presenting the analysis results of the PV systems under study, briefly the methodology used is illustrated. In the case of the single-phase 3 kVA inverter the signals of the output voltage and current, together with the corresponding DC

quantities, are sampled every five seconds during a half-day operation. For the three-phase 230 kVA inverter an Aron connection (Fig. 5.9) is used to perform power measurements with the same rate, obtaining the line-to-line voltage V_{12} and V_{32} , and the phase currents I_1 and I_3 , besides the DC voltage and current. All these measurements are performed during a clear-sky day without any shades on the PV modules. For the PQ analysis the quantities V_{12} and I_1 are examined to evaluate the *THD* of voltage and current, while the V_{31} voltage is reconstructed in order to calculate the three-phase unbalance.

In order to evaluate the impact of an unusual operation (shading effect) to power quality, the large industrial 834.5 kW_p BIPV plant of section 4.3. As already exposed, one of its three-phase 100 kVA inverters, which is supplied by the shaded PV array no. 5, is considered. A 10-cycle waveform is acquired for all the line voltages and currents at the inverter output (Fig. 5.10), in a morning of a January day. The harmonic analysis is performed with the related *THD* of current and voltage. In addition, the reconstruction of the fundamental-component phasors of the three phase voltages and currents are drawn. By the Fortescue decomposition the positive and negative components of phase 1 current are computed; thus, the three-phase unbalance is achieved. The Total Harmonic Distortion (*THD*) of voltage and current results from the RMS values of the fundamental component and the first 40 harmonic orders [58]

$$THD_V = \frac{1}{V_1} \sqrt{\sum_{k=2}^{40} V_k^2} \quad (5.1)$$

$$THD_I = \frac{1}{I_1} \sqrt{\sum_{k=2}^{40} I_k^2} \quad (5.2)$$

The three-phase unbalance is evaluated for three voltages (or currents) through the formula contained in [71] as

$$\frac{V^-}{V^+} = \sqrt{\frac{1 - \sqrt{3 - 6\beta}}{1 + \sqrt{3 + 6\beta}}} \quad (5.3)$$

with

$$\beta = \frac{V_1^4 + V_2^4 + V_3^4}{(V_1^2 + V_2^2 + V_3^2)^2} \quad (5.4)$$

The FFT implements the Digital Fourier Transform (DFT), evaluating the single amplitude of harmonic order components, starting from a sequence of a power of 2 discrete signal samples, as

$$\bar{X}(\omega_k) = \sum_{n=0}^{N-1} x_d(n) e^{-j2\pi kn/N} \quad (5.5)$$

where N is the total number of samples $x_d(n)$ of the signal $x(t)$, j is the imaginary unit, k is the inter-harmonic order with pulse ω_k . Another way, used here to compute the unbalance, is to find the negative and positive components, in order to compute their ratio.

Concerning the measurement performance of the automatic data acquisition system, the main specifications are:

- resolution of 16 bit and sampling rate of 51.2 kSa/s for the A/D-converter;
- accuracy of $\pm 0.1\%$ for voltage while $\pm 1.5\%$ for current and $\pm 1.6\%$ for power, due to clamp probes;
- FFT analysis up to the 50th harmonic order.

Specific software allows for analysing the measurements vs. time with the option of exporting the electrical quantities, in order to perform all the post-processing.

5.4 Experimental results

5.4.1 3 kVA and 230 kVA inverters

During normal operation, sweeping the output power from 20% to 100% of the rated value, the 3 kVA inverter shows a THD_I below the 5% limit fixed by the standard [60], while the THD_V remains under the 2% threshold (Fig. 5.11). As expected, since the inverter power size is small, the THD_V does not depend on the output power even at low power levels. The harmonic analysis of the current

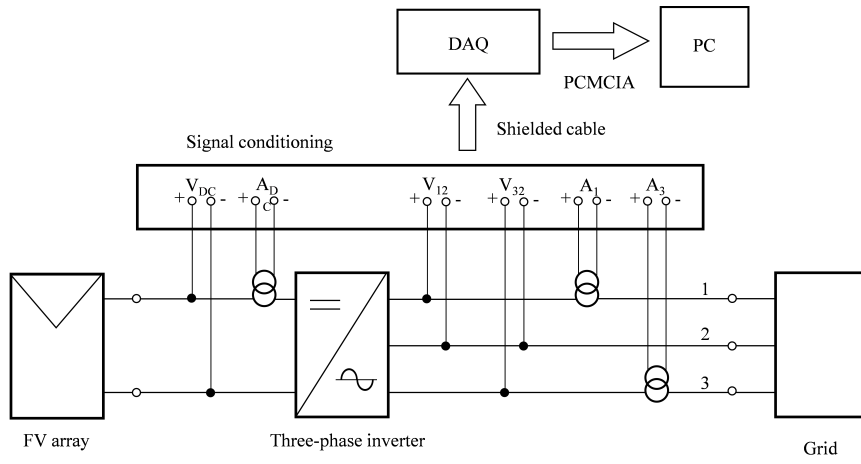

Figure 5.9: Measurement scheme for 230 kVA inverter.

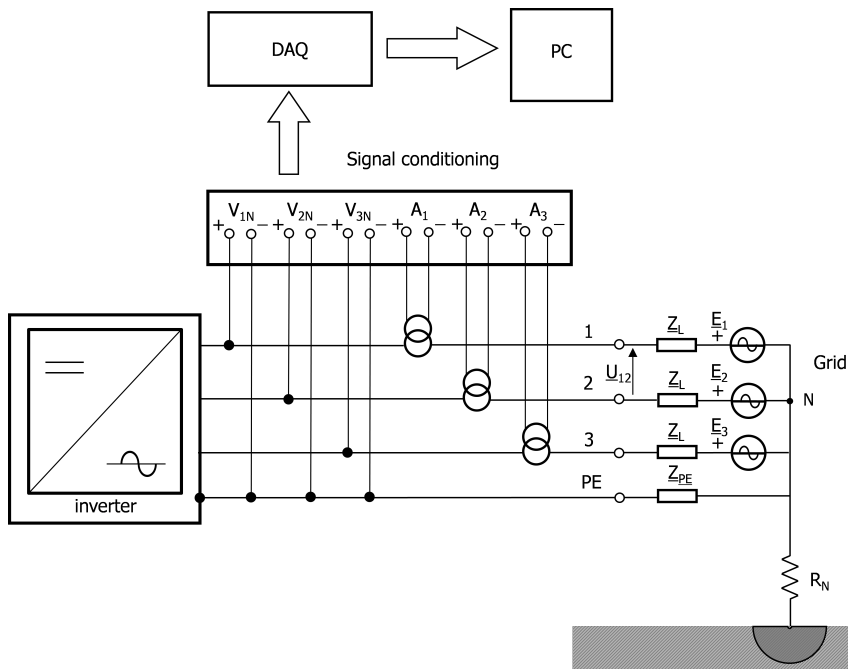

Figure 5.10: Measurement scheme for 100 kVA inverter.

highlights a strong contribution of the first odd harmonics, from III (typical for single-phase grid) to IX in Fig. 5.12. In the case of the 230 kVA inverter, even if the THD_I limit is fulfilled, the THD_V exceeds the limit maybe for high harmonic presence in the MV grid (Fig. 5.13). It is verified that for both inverters, in the 20–100% range of rated power, the active/reactive power control holds unitary power factor, compensating for the reactive power demand of the grid interface stage (Fig. 5.14 and Fig. 5.15).

Regarding the three-phase unbalance for the 230 kVA inverter the computation shows an average voltage unbalance equal to 0.27%, while for the current the value is around 0.60%.

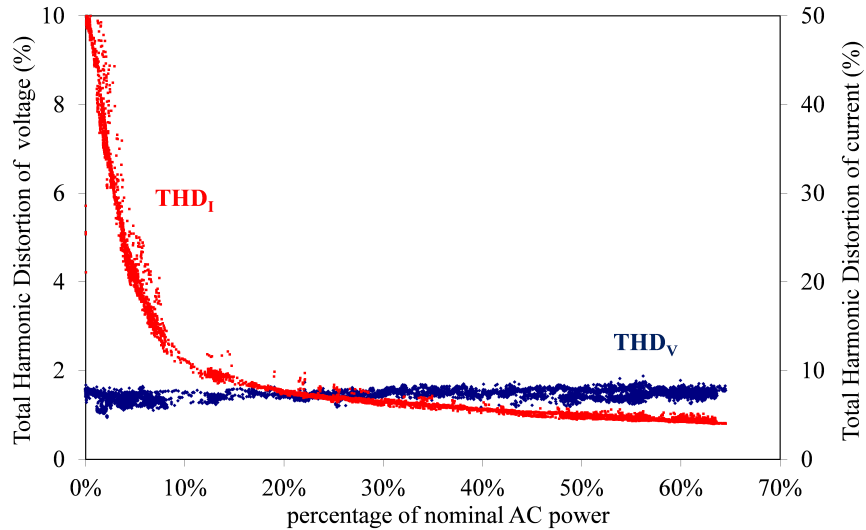

Figure 5.11: THD of AC current and voltage for a 3 kVA inverter.

5.4.2 Case study: shading effect on a large BIPV plant

As introduced in the previous section, it has been performed the PQ analysis of an inverter supplied by a PV array affected by shade over its modules. The implications on the PQ can be seen in the waveforms at the inverter output (Fig. 5.16) and in the harmonic content of the currents (Fig. 5.17). In particular, in the current waveforms a high frequency fluctuation is evident, that is due to the PWM technique typical for the inverter manufacturers (3 kHz).

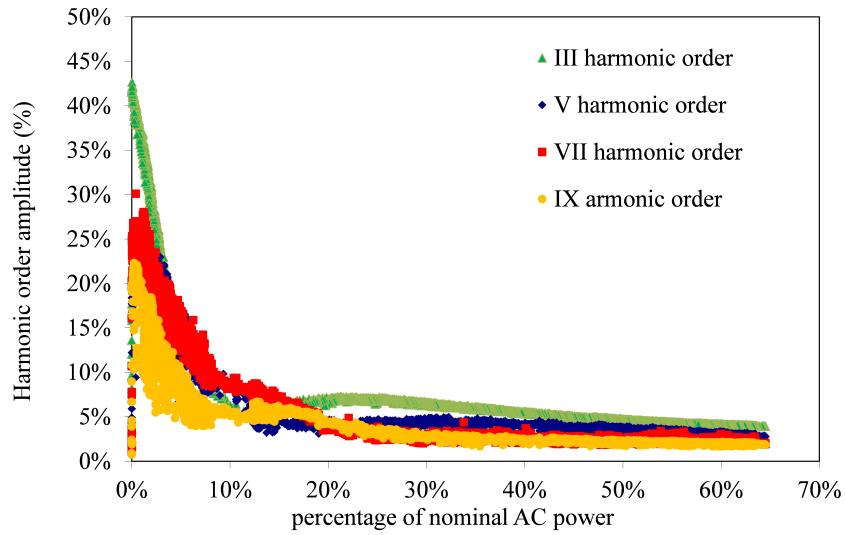

Figure 5.12: Amplitude of harmonic orders in terms of percentage of IAC RMS for a 3 kVA inverter.

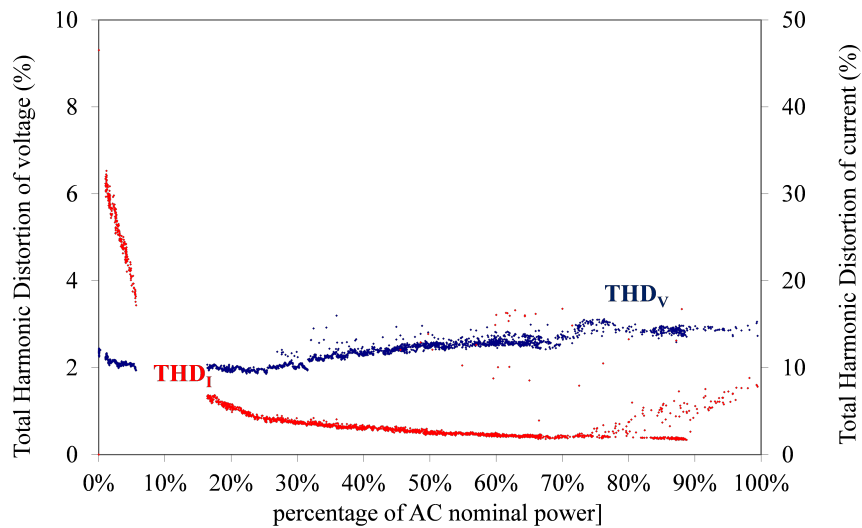

Figure 5.13: *THD* of AC current and voltage for a phase of a 230 kVA inverter.

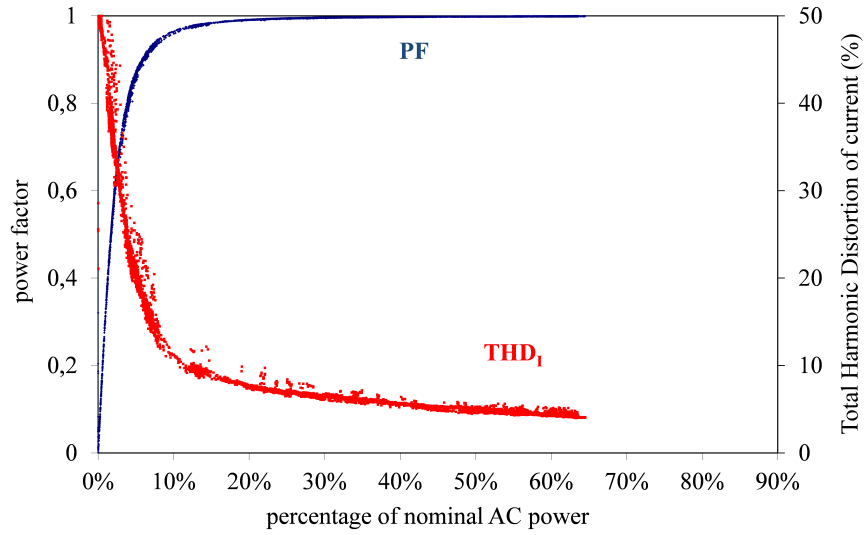

Figure 5.14: Power factor and THD_I for a 3 kVA inverter.

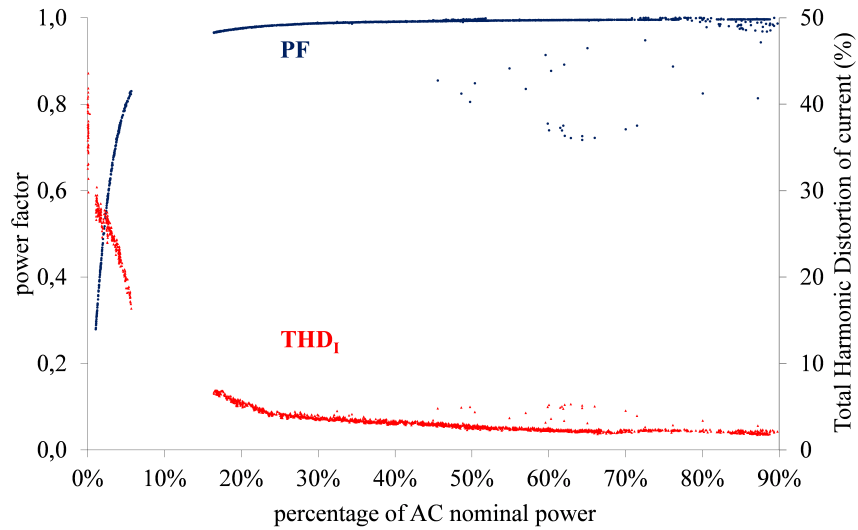

Figure 5.15: Power factor and THD_I for a 230 kVA inverter.

The voltage THD_V parameter results to be very low ($\approx 0.9\%$), while for the currents THD_I exhibits values around 20%. The reconstruction of the phasors of the fundamental of the three phase voltages and currents, with the positive (I_1^+) and negative (I_1^-) components of phase 1 current, shows a remarkable negative component (Fig. 5.18). In fact, the three-phase unbalance for the voltage results to be 0.084%, while the current unbalance is 5.14%.

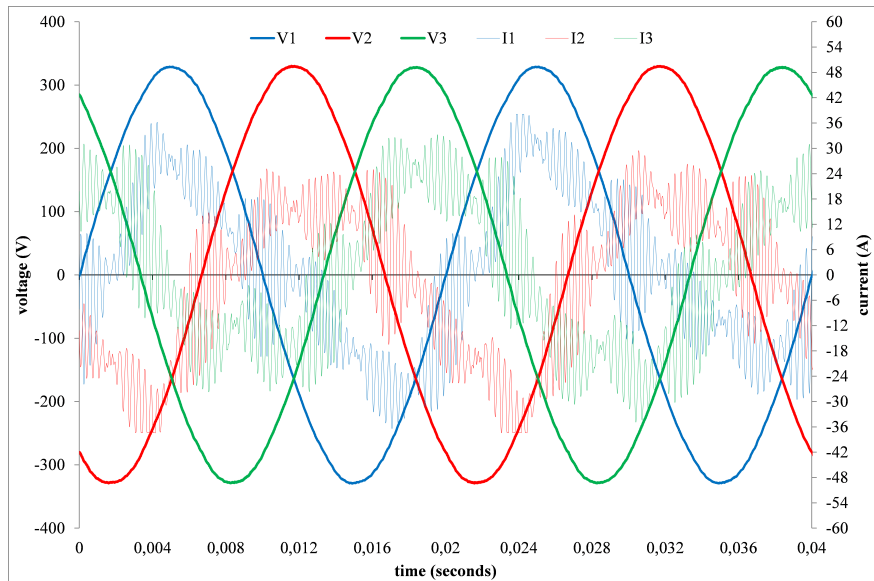

Figure 5.16: Waveforms of the three phase voltages and currents at the 100 kVA inverter output.

5.5 Concluding remarks

The chapter has shown the PQ impact in three real cases characterized by an extended power range of photovoltaic systems from a few kilowatts to some hundreds of kilowatts. If, in case of totally irradiated PV modules, the PQ parameters satisfy the limits imposed by the standards, when a partial shading condition occurs, the harmonics and unbalance of the current and the power factor become significant. This is also due to the fact that the shading effect in PV modules corresponds to power levels of about 10–30% of the rated power.

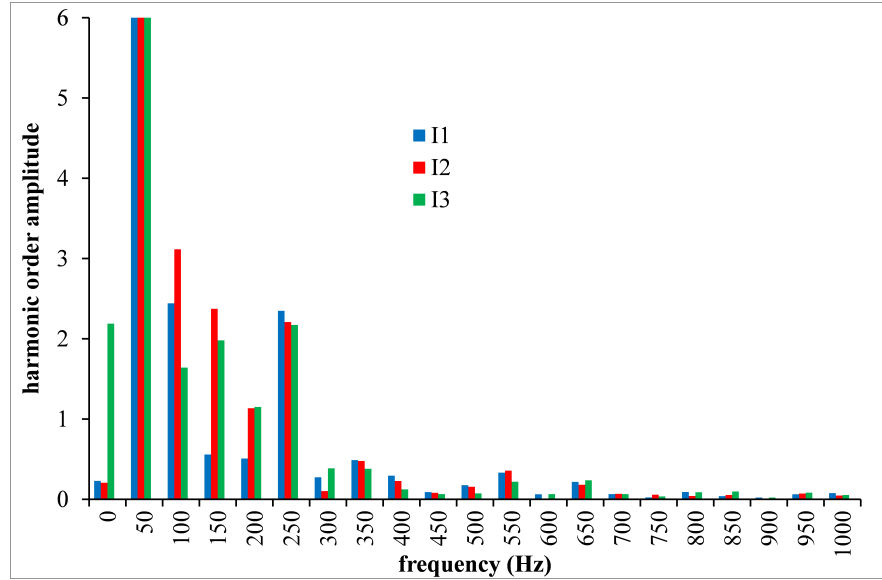

Figure 5.17: Harmonic content of the three-phase currents (100 kVA inverter).

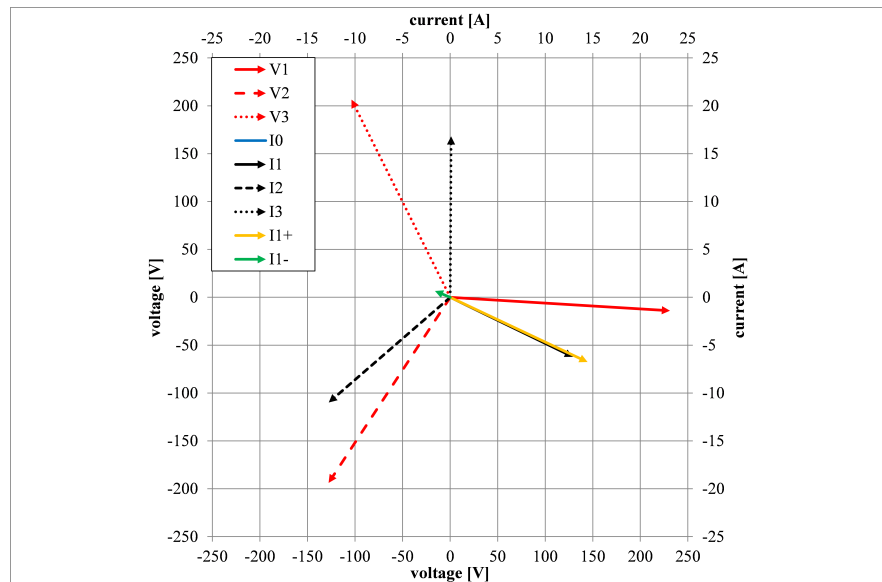

Figure 5.18: Phasors of the voltages (red) and currents (black) with the positive (yellow) and negative (green) components of phase 1 current.

The chapter 6 will deal with the current unbalance for the case study BIPV system in much more detail, exploring PQ analysis' methodologies alternative to the Standard PQ indicators.

