

Rider–handlebar injury in two-wheel frontal collisions

Original

Rider–handlebar injury in two-wheel frontal collisions / Elisabetta M., Zanetti; Giordano, Franceschini; Audenino, Alberto.
- In: JOURNAL OF THE MECHANICAL BEHAVIOR OF BIOMEDICAL MATERIALS. - ISSN 1751-6161. - 33:(2014), pp.
84-92. [10.1016/j.jmbbm.2013.01.011]

Availability:

This version is available at: 11583/2511674 since:

Publisher:

Elsevier

Published

DOI:10.1016/j.jmbbm.2013.01.011

Terms of use:

This article is made available under terms and conditions as specified in the corresponding bibliographic description in the repository

Publisher copyright

(Article begins on next page)

RIDER – HANDLEBAR INJURY IN TWO-WHEEL FRONTAL COLLISIONS

Elisabetta M. Zanetti^a, Giordano Franceschini^a, Paolo B. Pascolo

^aDepartment of Industrial Engineering – University of Perugia, Via Duranti 67, 06125 Perugia, ITALY,
elisabetta.zanetti@unipg.it

Journal of the Mechanical Behavior of Biomedical Materials

Available online 11 February 2013

<http://dx.doi.org/10.1016/j.jmbbm.2013.01.011>,

Corresponding Author: Dr. Elisabetta M. Zanetti

Department of Industrial Engineering

University of Perugia

Via Duranti 65

06125 Perugia (ITALY)

elisabetta.zanetti@unipg.it

Tel: +39 075 5853748

Fax: +39 075 5853703

Abstract

This work analyses blunt abdominal trauma produced by driver-handlebar collision, in low speed two-wheel accidents. A simplified dynamic model is introduced, whose parameters have been estimated on the basis of cadaver tests.

This model allows calculating the peak impact force and the abdominal penetration depth; therefore the likelihood of occurrence of serious injuries can be estimated for different masses of contacting bodies and different speeds. Results have been checked against literature data and true-accident reports.

Numerical simulations demonstrate that serious injuries (AIS>3) can occur even at low speeds (<20 km/h), therefore the design of protective clothing is recommendable.

The model can allow both the analysis of true accident data and the virtual testing of protective equipment in the conceptual design phase.

Introduction

Thoracic and abdominal injuries have been found to be common among motorcyclists accidents and to be associated with a higher risk of mortality (Kraus et al., 2002); in detail, the abdomen gains the third place among the most seriously injured anatomic regions, abdominal injury accounts for 20% of hospitalized motorcyclists injuries (Dischinger et al., 2006); lastly, head injury followed by chest and abdominal trauma were found to predict a reduced survival rate (Ankarath et al., 2002). Although many studies have documented the role of trunk injuries resulting from vehicular crashes (Morris et al., 2002, 2003), few have addressed these injuries among motorcyclists; in an analysis of motorcycle-related hospitalizations in the U.S, thoracic injuries are not even mentioned among the principal diagnoses as part of the 2001 Nationwide Inpatient Sample of the Healthcare Cost and Utilization Project (Dischinger et al., 2006).

More specifically, the incidence of abdominal injuries due to handlebar collision is likely to be underestimated due to insufficient documentation of the circumstances of injury events and a lack of applicable emergency codes specific for handlebar injury (Mezhir et al., 2007). On the other hand, data concerning impact with the handlebar in slow speed bicycling crashes demonstrate that this kind of injury can occur, even at low speed, it has a significant incidence, and it can lead to dramatic consequences: this phenomenon has been identified as a mechanism of life threatening injuries in children, and as the predominant cause of abdominal injury in children age 6–10 years (Bergqvist et al., 1985; Arkovitz et al., 1997).

In 1981, Hurt and his staff analysed 3600 motorcycle traffic accident reports in Los Angeles (Hurt et al., 1981); this study is now 30 years old, but it is still a reference for its completeness; one of its findings has been that the median pre-crash speed is 29.8 mph; analysing low-speed range is therefore a justifiable choice.

Considering secondary prevention issues for two-wheel drivers, the use of helmets has been widely proved to limit the incidence of head injury (Liu et al., 2008), while no true prevention has been really done in relation to chest and abdominal injury, apart from the recommendation of careful diagnosis and early treatment (Kraus et al., 2002). The above cited evidences suggest the importance of protecting these vital organs in addition to the head in motorcycle crashes and therefore the need for protective clothing in addition to helmets to reduce the mortality burden in this population. (ACEM, 2004; Haworth et al., 1997; Hurt et al., 1981). The design of protective systems can be aided by an understanding of injury mechanisms.

As said above, most abdominal injuries occur in automobile accidents (Stalnaker and Ulman, 1985); therefore injury criteria have been developed with reference to car accident with frontal or lateral impact. In frontal impact, driver-steering wheel collision can be assimilated to scooter-driver handlebar collision; the incidence of these events has been greatly reduced due to restraining systems and airbags; however, in the past, the study of this phenomenon has led to the description of abdominal injury mechanics, the execution of cadaver tests in order to identify injury predictors, and the development of simplified dynamical models which can be used in order to simulate real accidents and protective equipment efficacy.

From an anatomical point of view, the abdomen is even more vulnerable to injury than the chest because there isn't a bony structure like the ribcage to protect internal organs in front and lateral impacts. In detail, blunt impact of the upper abdomen is often reported where the liver and spleen have been injured: in the AIS 3 categories, the liver is the most frequently injured organ in frontal, right side and far side crashes; this is followed by spleen trauma (Yonagandan et al., 2001). In the liver, compression leads to the internal pressure rise; tensile or shear strains so generated eventually can lead to the laceration of the major hepatic vessels resulting in hemoperitoneum. Abdominal impacts can also cause the relative movement between lobes of the liver, stressing the vascular attachment at the hilar region (Viano and Andrzejak, 1993).

Numerical models can allow the virtual evaluation of accident mechanics and of the efficacy of protective equipment; very complex models have been developed for the prediction of trauma and human body response in auto crash (Forbes et al., 2005): these models can allow a predictive evaluation of injury under a variety of loading conditions, once the mechanical properties of simulated organs have been identified (Miller, 1991), and the models themselves have been evaluated on the basis of experimental data.

A simplified approach has been here employed since the objective of the numerical simulation was the only assessment of peak impact force, instead of stress and strain distributions. Besides, the variety of possible loading conditions has been strictly limited to the analysis of the frontal impact of a rigid body, at low speed, and the inquiry has been focused on the lower abdomen; the lumped-mass model of the chest developed by Lobdell et al. (1973) was therefore taken as a reference; it was simplified and characterized on the basis of experimental data obtained by Nusholtz et al. (1988, 1985) and the respective results provisions have been verified on the basis of literature data and real accidents data. This model can be numerically solved in few seconds, providing information about critical speeds in motorcycle-car frontal accidents, and giving an indication of the probability of injury occurrence. Model predictions have been verified on the basis of literature data and real accidents data.

Materials and methods

A single mass, one and a half-degree-of-freedom dynamic model has been developed in Simulink (by MatlabTM); as illustrated in figure 1a, it was made of a spring, in series with a Voigt spring-dashpot system. Considering Nusholtz tests on unembalmed cadavers (Nusholtz et al., 1988), the input displacement is the impactor displacement; considering true accident data, the model input is the displacement of the vehicle and the scooter moving together (x_c) after the collision. The hypothesis behind this model is that the driver keeps moving horizontally at the same speed he had before the impact between the scooter and the car, while the scooter and its handlebar move together with the car at a speed which can be estimated considering an inelastic impact; this hypothesis holds as far as the driver does not hit any other body (the handlebar is considered to be the first striking object), and the force exchange between the driver and his seat can be overlooked (driver sliding with no friction or losing contact with its seat); it is a conservative assumption since it leads to the most pessimistic estimate of driver speed. Besides, it should be emphasised

that the hypothesis of forward trunk projection holds for low-speed accidents; otherwise more complex multi-body models should be used to forecast trunk trajectory (Serre and Llari, 2010). Momentum conservation equation is:

$$(M_D + M_S)v_{s,i} + M_C v_{C,i} = (M_S + M_C)v_{C,f} + M_D v_{S,i} \quad (1)$$

$$v_{C,f} = \frac{M_S v_{s,i} + M_C v_{C,i}}{(M_S + M_C)} \quad (2)$$

Where:

- M_D, M_S, M_C represent driver, scooter, car mass, respectively;
- $v_{s,i}, v_{C,i}$ are the initial speed of the scooter and the car, respectively;
- $v_{C,f}$ is the final speed of the car and the scooter, moving together.

Other inputs of the dynamic model simulating the true accident are the velocity of the driver v_D that is coincident with the scooter velocity before the impact ($v_{s,i}$), and the driver mass M_D . In performed simulations, the impact speed has been varied between 5 to 50 km/h (corresponding to 1.4-14 m/s) at step of 5 km/h, both for the car and for the scooter; the mass of the driver has been set equal to 80 kg, the mass of the scooter has been supposed to be 150 kg, the mass of the car has been put equal to 1500 kg, having considered C class European vehicle.

The lower abdomen stiffness and viscous damping K_2 and c_2 , and skin stiffness K_1 have been estimated fitting Nusholtz tests on unembalmed human cadavers, where a steering wheel assembly was used to impact the thoracic abdominal region with a 18 kg pendulum mass (Nusholtz et al., 1988); five cadavers have been impacted at high speed in the lower abdominal region, the respective data are reported in Table 1, while force-displacements curves are reported in the cited publication.

The transfer function has been so defined in the time domain:

$$G(t) = \frac{F(t)}{C(t)} \quad (3)$$

Where both $F(t)$ and $C(t)$ are experimental data representing the abdominal force and abdominal compression, the fitting equation for the Laplace transform of transfer function $G(s)$ is reported in the following:

$$G(s) = A \frac{1+s\cdot T_2}{1+s\cdot T_1} \quad (4)$$

Transfer function fitting has been performed through a Singular Value Decomposition algorithm; the maximum number of iterations has been set equal to 50; the algorithm minimizes an objective function that is the sum of error squares, iterations are terminated when the percentage decrement of the objective function is below 0.01 (tolerance limit).

Parameters A, T_2, T_1 can be related to the mechanical parameters K_1, K_2 and c through the following calculations:

In time domain:

$$F(t) = K_1(x_1 - x_H) = K_2(x_D - x_1) + c_2(\dot{x}_D - \dot{x}_1) \quad (5)$$

In frequency domain:

$$F(s) = K_1(x_1 - x_H) - K_2(x_D - x_1) + c_2 s(x_D - x_1) \quad (6)$$

$$G(s) C(s) = x_D - x_H = (x_1 - x_H) + (x_D - x_1) = \frac{F}{K_1} + \frac{F}{(K_2 + c_2 s)} \quad (7)$$

$$G(s) = \frac{F(s)}{\frac{F}{K_1} + \frac{F}{(K_2 + c_2 s)}} = \frac{(K_1 K_2) + s(K_1 c_2)}{(K_1 + K_2) + s(c_2)} \cdot \frac{(K_1 K_2)}{(K_1 + K_2)} \cdot \frac{1 + s \frac{c_2}{K_2}}{1 + s \frac{c_2}{(K_1 + K_2)}} \quad (8)$$

Where x_H and x_D represent handlebar and driver displacements, respectively, while x_1 is an inner abdominal displacement (figure 1)

Substituting into eq 4:

$$A = \frac{(K_1 K_2)}{(K_1 + K_2)} \quad (9)$$

$$T_s = \frac{c_2}{K_2} \quad (10)$$

$$T_1 = \frac{c_2}{(K_1 + K_2)} \quad (11)$$

Therefore:

$$K_1 = A \frac{T_s}{T_1} \quad (12)$$

$$K_2 = \frac{K_1}{\frac{T_s}{T_1} - 1} \quad (13)$$

$$c_2 = T_s \cdot K_2 \quad (14)$$

Results

The fitting of experimental curves obtained on cadaver tests has produced results reported in Tab. 2; a sample curve is reported in fig. 2; the regression coefficient was good and did not improve significantly and systematically employing higher order linear models.

On the whole, 121 experiments have been performed: both scooter and car speeds were varied from 0 to 50 km/h with a step of 5 km/h, and a full factorial plane has been created (eleven levels, two factors).

Typical force histories are reported in figure 3: the force increases sharply to a peak value and after it lowers with a smoother trend; the curves have been parameterised with reference to the scooter and car initial speeds Fig. 4 displays some typical patterns of abdominal compression history: the curve is initially tangential to the horizontal axis, successively, it changes its convexity up to its maximum value; the simulation was stopped when the abdominal force reached a null value.

The measured peak force has resulted to vary up to 28% depending on the simulated cadaver response; at the extreme condition that is when the car and the scooter move at opposite 50 km/h speed, the peak abdominal force ranges from 29878 to 45640 N. The measured abdominal compression could vary up to 46% depending on the simulated cadaver response. It should be emphasised that whenever the scooter initial speed is equal to or lower than the car initial speed, the final car speed is very close to its initial value due to the high ratio of the car mass on the scooter mass (eq 2); therefore, the abdominal force and compression result to be monotonously related to the sum of the absolute values of scooter and car initial speeds: in fact, according to the model (figure 1), the relevant input is the relative speed between the driver and the handlebar, while, according to the hypotheses made in the "Materials and Methods" section, the driver speed is equal to the initial scooter speed, and the handlebar speed is equal to the final car speed; as said above, this last is very close to the initial car speed.

The probability of occurrence of serious injuries has been calculated on the basis of two extremely different force threshold levels, concerning the frontal side of the lower abdomen, calculated by means of different experimental set ups: 2930 N (25% risk, AIS 3+ according to Miller, 1989, who studied the response of the lower abdomen to belt restraint at 1.6-6.6 m/s speed range) or 7600 N (AIS 2 according to Trosseille et al., 2002, who studied the abdominal response to 8.2-11.7 m/s high-speed seatbelt loading). Figure 5 reports the number of simulated cadaver response which would produce an injury score below AIS 3+ or AIS 2 according to Miller's or Trosseille's thresholds, respectively, for each couple of scooter-car speeds. In the case of scooter and vehicle moving at 10 km/h opposite speeds, for example, all five simulated cadaver responses result in AIS3+ injury, according to Miller, 1991; all responses would result in no injury, according to Trosseille et al., 2002. According to the same fig. 5, whenever the sum of the absolute values of car-scooter speeds is beyond 15 km/h, there is at least a 25% risk of occurrence of a serious injury, according to Miller, 1989: all cadaver responses have produced a peak abdominal force above 2930 N.

Discussion

Lobdell et al. (1973) introduced a lumped-mass model to simulate human thoracic response (fig. 7); his model was more complex, being based on Kroell tests on the upper ribcage (Kroell et al., 1986); figure 6 reports a modified version (by Viano, 1987) where the compliance of the skin and of the impacting mass has been taken into account. Stiffnesses k_1 and k_2 calculated in this work may correspond to k_{12} , k_{23i} , k_{23s} , k_{ve23} , in Lobdell's model, while damping c_2 could correspond to c_{23} and c_{ve23} contributes. A comparison between the respective values is reported in Tab. 2: the order of magnitude is the same even if values are quite different. Differences are likely to be due to variations in the model (Lobdell's model has a higher number of degrees of freedom), and in the experimental set up: more specifically, differences concern the impact point on cadavers (upper ribcage vs. lower abdomen), impactor geometry (hub vs. steering wheel), impact speed (4.3-6.7 m/s vs. 6.5-10.8 m/s), and cadaver preparation (unrepressurised vs. pressurised). According to Cavanaugh et al. (1985), and to Nusholtz et al. (1988) the lower abdominal stiffness can be set equal to 53.9 kN/m (4.9 to 13.0 m/s speed) and to 52.7 kN/m (3.9 to 10.8 m/s, initial slope) respectively; force/displacement data numerically simulated in this work produced a tangent stiffness (initial slope of the abdominal force vs abdominal compression curve) ranging from 49 kN/m to 71 kN/m (8 m/s impact). An analytical comparison can be performed considering very low speeds, or better, speeds which would make dashpot contribute very small compared to spring contribute; in this case, the model of fig. 6 would be equivalent to the series of k_{12} spring with the parallel between $k_{23,i}$ and $k_{23,s}$ springs; the equivalent stiffness would therefore be 61.6 kN/m. Under the same hypothesis, the model of fig. 1, would lead to an equivalent stiffness equal to the series between k_1 and k_2 springs; the result is an average stiffness equal to 59.9 kN/m. On the contrary, the two models produce very different results if 'very high' speeds are considered, or better speeds which would make dashpot contribute very high compared to spring contribute: in this case, the equivalent stiffness is k_{12} for modified Lobdell's model (fig. 6) and k_1 for the simplified model of figure 1. Finally, it should be considered that even when the initial speed is very high, the speed pattern resulting from linear models is sinusoidal therefore speed values ranging from zero to their maximum should be considered, leading to a behaviour lying between the two above described scenarios. An even simpler model was introduced by Trosseille et al., 2002; these authors investigated high-speed seat belt loading and they modelled the abdomen as a parallel spring-damper system; the major shortcomings with their model is that the abdomen should behave as infinitely stiff at 'very high' speeds. Differences in stiffness and damping values between their model and the here introduced model are likely to be due to different contact areas between their experiment and Nusholtz's experiment.

The validity of the model can be checked against true experimental data: according to Lau et al. (1987) who made experiment on swine, abdominal injury occurs within the initial 15 ms of wheel contact, at a steering wheel velocity equal to 32 km/h. When this test is numerically simulated with the model here developed ($M=45$ kg; $v_D=0$ m/s; $v_H=8.9$ m/s), the abdominal force reaches injury levels after 6.0-9.2 ms, depending on simulated cadaver model. Miller (1991) performed impactor tests with anaesthetised swine subjects: these last were impacted with a steering wheel with velocities between 1.7 and 12.4 m/s, and the compression reached 54.5 %; when this test is simulated with the introduced model ($M=45$ kg; $v_D=0$ m/s; $v_H=1.2-9.6$ m/s), peak compression has resulted to be equal to 49.7%.

The model has been checked also against true accident data: a two-passenger scooter moving at 20 km/h speed impacts a car moving at 9.6 km/h; as a consequence of collision, the scooter driver sustains serious injury at the gall bladder (AIS=3). Data have been taken from a police report; the speeds have been estimated both on the basis of ballistic considerations and on the basis of vehicles deformations; the two methods have led to consistent speed estimates; this example demonstrates how abdominal injury can occur even in low-speed accidents. The numerical simulation is performed with $M=150$ kg (sum of the two passenger masses), $v_D=5.55$ m/s, $v_H=1.36$ m/s; results demonstrate that all simulated cadaver responses produce peak abdominal force far beyond AIS3+ limits (25% risk), according to Miller, 1989; on the contrary, only two out of five cadaver responses would sustain mild injury according to Trosseille et al., 2002. Miller's force threshold level seems therefore to be more reliable; the reason may be that a localised impact is taking place in reality and the contact between the belt and the pig's abdomen in Miller's experiments was very confined, while in Trosseille's experiments the contact area is very wide; another aspect concerns force measurement method: Trosseille et al., 2002 actually measures the belt tension and the derivation of abdominal contact force is not so immediate due to friction. Steering wheel impact experiments would more closely replicate abdomen-handlebar impact, however these experiments were usually performed considering the middle abdomen and therefore their results cannot be applied to the present case.

Newgard et al. (2005) analysed the 1995 to 2002 National Automotive Sampling System Crashworthiness Data System database; they found that average delta speed producing serious abdominal injury (AIS \geq 3) was equal to 39.8 km/h, having considered over 33000 drivers. In this case, eq (1) can be implemented supposing $m_C=m_D$; eq(5) model holds if the car driver is supposed to be free to translate like the scooter driver; under these assumptions, the model foresees no AIS=3 injury level when delta speed is below 20 km/h; 3 out of five cadaver responses with no AIS=3 injury levels for delta speed ranging from 20 to 30 km/h; all cadaver responses with above AIS=3 injury levels for delta speed higher than 30 km/h.

The results of fig. 5 have been obtained having chosen to adopt an injury criterion based on peak abdominal force; other abdominal injury criteria have been introduced in literature: the most used is the 'viscous criterion' where the product of compression and velocity (V_C) is considered; this criterion has been proven to be a good predictor in steering wheel tests with anaesthetised swine (Miller, 1991; Lau et al., 1987; Viano and Lau 1988); it seemed to be inappropriate for unembalmed cadavers (Nusholtz et al., 1985), even if last results may have been biased by performing repeated tests on the same cadaver. On the whole, both viscous and peak force criteria have proven to work well: whenever both criteria have been tested on the same experiments, both criteria demonstrated to be good estimators, VC criterion performing the best (Miller, 1981, Rouhana, 1986); besides, the experimental measurement of impact force is more critical than the measurement of compression and speed. Nevertheless, in this work the peak force criterion has been adopted, since it is likely to be more general in terms of impact speed (Hardy et al., 2001). A further numerical test has been made in order to evaluate the difference between these two criteria, were injury

probability has been estimated on the basis of VC criterion (AIS3+ threshold = 1.29 m/s, according to Miller, 1991; AIS2 threshold 1.69 m/s, according to Trosseille et al., 2002). Results have been reported in figure 7: whenever delta car-scooter speed is beyond 25 km/h, a serious injury is very likely to occur; this result is halfway between those obtained with the peak force criterion and the two different threshold levels (figure 5).

This model does not allow taking into account the stiffness of the impacting body which was considered to play a minor role being much higher than abdominal stiffness: whenever the last condition is not satisfied, a spring should be put in series with k_1 .

Conclusions

A virtual model for the analysis of lower abdominal injuries has been developed; it was characterised on the basis of five cadaver tests, so it can give a clue on inter-subject variability. The model has been used for the analysis of driver-handlebar collision in low-speed scooter-car accident: it demonstrated that this kind of accident can take place even at low speed, with relevant implications for what concerns the definition of protective equipment. Different injury criteria with different threshold values have been tested and discussed.

On the whole, a simple instrument has been set up, which can be used for the analysis of lower abdominal injuries.

References

- ACEM, 2004. MAIDS: In-depth investigation of accidents involving powered two-wheelers, Final Report 1.2. Association of European Motorcycle Manufacturers, Brussels. <http://www.maids-study.eu/downloads.php>, Last Access April 13th 2012.
- Ankarath, S., Giannoudis, P.V., Barlow, I., Bellamy, M.C., Matthews S.J., Smith R.M., 2002. Injury patterns associated with mortality following motorcycle crashes. *Injury*. 33, 473-477.
- Arkovitz, M.S., Johnson, N., Garcia, V.F., 1997. Pancreatic trauma in children: mechanisms of injury. *J. Trauma* 42, 49-53.
- Bergqvist, D., Hedelin, H., Lindblad, B., Matzsch, T., 1985. Abdominal injuries in children: an analysis of 348 cases. *Injury* 16, 217-220.
- Cavanaugh, J.M., Nyquist, G.W., Goldberg, S.J., King, A.I., 1986 Lower abdominal impact tolerance and response. *Stapp Car Crash J* 30, 861878.
- Dischinger, P.C., Ryb, G.E., Ho, S.M., Braver, E.R., 2006. Injury Patterns and Severity Among Hospitalized Motorcyclists: A Comparison of Younger and Older Riders. *Annu. Proc. Assoc. Adv. Automot. Med.* 50, 237-249.
- Forbes, P.A., Cronin, D.S., Deng, Y.C., Boismenu, M., 2005. Numerical Human Model to Predict Side Impact Thoracic Trauma, in: Gilchrist, M.D. (Ed.), *IUTAM Symposium on Impact Biomechanics: From Fundamental Insights to Applications*, Springer, Netherlands, pp. 441-450.
- Hardy, W.N., Schneider, L.W., Rouhana, S.W., 2001. Abdominal impact response to rigid-bar, seatbelt, and airbag loading. *Stapp Car Crash J.* 45, 1-32.

- Haworth, Pronk, N., Brunen, I., Smith, R., 1997. Case-Control Study of Motorcycle Crashes Report CR 174, Australian Transport Safety Bureau, Canberra.
- Hurt, H.H., Ouellet, J.V., Thom, D.R., 1981. Motorcycle Accident Cause Factors and Identification of Countermeasures, Technical Report, DOT HS-5-01160. Vol. 1, National Highway Traffic Safety Administration, Washington DC.
- Kraus, J.F., Peek-Asa, C., Cryer, H.G., 2002. Incidence, severity, and patterns of intrathoracic and intra-abdominal injuries in motorcycle crashes. *J. Trauma* 52, 548–553.
- Kroell, C.K., Allen, S.D., Warner, C.Y. Perl, T.R., 1986. Interrelationship of Velocity and Chest Compression in Blunt Thoracic Impact to Swine TI, *Stapp Car Crash J.* 30, 99-122.
- Lau, I.V., Horsch, J.D., Viano, D.C., Andrzejak, D.V., 1987. Biomechanics of Liver Injury by Steering Wheel Loading. *J. Trauma* 27, 225-235.
- Liu, B.C., Ivers, R., Norton, R., Boufous, S., Blows, S., Lo, S.K., 2008. Helmets for preventing injury in motorcycle riders. *Cochrane Database Syst. Rev.* 1, CD004333.
- Lobdell, T.E., Kroell, C.K., Schneider, D.C., Hering, W.E., Nahum, A.M., 1973. Impact response of the human thorax, in King, W.F., Mertz, H.J. (Eds.), *Human Impact Response Measurement and Simulation*. Plenum Press, New York, pp. 201–245.
- Mezhir, J.J., Glynn, L., Liu, D.C., Statter, M.B., 2007. Handlebar injuries in children: should we raise the bar of suspicion? *Am. Surg.* 73, 807-810.
- Miller, M.A., (1989). The Biomechanical Response of the Lower Abdomen to Belt Restraint Loading. *Journal of Trauma* 29, 1571 – 1584.
- Miller, M.A., 1991. Tolerance to Steering Wheel-Induced Lower Abdominal Injury. *J. Trauma* 31, 1332-1339.
- Morris, A., Welsh, R., Frampton, R., Charlton, J., Fildes, B., 2002. An overview of requirements for the crash protection of older drivers. *Proc AAAM.* 46, 141–156.
- Morris, A., Welsh, R., Hassan, A., 2003. Requirements for the crash protection of older vehicle passengers. *Proc. AAAM.* 47, 165–180.
- Newgard, C.D., Lewis, R.J., Kraus, J.F., 2005. Steering Wheel Deformity and Serious Thoracic or Abdominal Injury Among Drivers and Passengers Involved in Motor Vehicle Crashes. *Ann. Emerg. Med.* 45, 43-50.
- Nusholtz, G.S., Kaiker, P.S., Huelke, D.F., Suggitt, B.R., 1985. Thoraco-Abdominal Response to Steering Wheel Impacts, *Stapp Car Crash J.* 29, 221-267.
- Nusholtz, G., Kaiker, P., Lehman, R. 1988. Steering system abdominal impact trauma, University of Michigan Transportation Research Report no. 88-19. <http://deepblue.lib.umich.edu/handle/2027.42/772>, last access April 14th 2012.
- Rouhana, S. W., Ridella, S. A., Viano, D. C., 1986. The Effects of Limiting Impact Force on Abdominal Injury: A Preliminary Study. *Stapp Car Crash J.* 30, 65-79.
- Serre, T., Llari, M., 2010. Numerical analysis of the impact between a PTW rider and a car in different accident configuration. *IFMBE Proceedings* 31, 521-524, DOI: 10.1007/978-3-642-14515-5_133

Stalnaker, R.L., Ulman, M.S., 1985. Abdominal trauma — review, response, and criteria. *Stapp Car Crash J.* 29, 1-16.

Trosseille, X., Le-Coz, J.Y., Potier, P., Lassau, J.P., 2002. Abdominal response to high-speed seatbelt loading. *Stapp Car Crash J.* 46, 71- 79.

Viano, D.C., 1987. Evaluation of the benefit of energy-absorbing materials for side impact protection. SAE Technical Paper 872212, doi:10.4271/872212.

Viano, D.C., Lau, I.V., 1988. A Viscous Tolerance Criterion For Soft Tissue Injury Assessment. *J. Biomech.* 21, 387-399.

Viano, D.C, Andrzejak, D.V., 1993. Biomechanics of abdominal injuries by armrest loading. *J. Trauma* 34, 105-15.

Yoganandan, N., Pintar, F.A., Maltese, M.R., 2001. Biomechanics of abdominal injuries. *Crit. Rev. Biomed. Eng.* 29, 173-246.

Table 1

Cadaver Identifier	Height [m]	Weight [kg]	BMI [kg/m ²]	Peak Force [N]	Peak Deflection [m]	Impact Speed [m/s]	Notes
86m006	1.80	70.1	21.64	8900	0.17	10	Unrepressurized
86m016	1.68	40.2	14.18	5300	0.09	6.5	Repressurized
86m026	1.64	57.5	21.25	6200	0.10	7.5	Repressurized
86m042	1.76	50	16.10	8400	0.14	10.8	Repressurized
86m052	1.62	70.3	26.85	6700	0.15	9.3	Repressurized
Average	1.70	57.6	20.00				
Max Dev.	9.82	17.4	6.85				

Table 2

Cadaver identifier	K ₁ [kN/m]	K ₂ [kN/m]	c [Ns/m]	R ²
86m006	82.34	234.44	1349.8	0.70
86m016	112.23	635.99	973.4	0.78
86m026	67.48	382.38	5693.1	0.77
86m042	101.98	71.10	1693.3	0.77
86m052	64.68	137.08	1763.0	0.75
Lobdell's model (Lobdell et al., 1973)	k ₁₂ =281 kN/m; k _{23i} =26.3 kN/m		C ₂₃ =525 Ns/m	
	k _{23s} =52.6 kN/m; k _{v23} =13.2 kN/m		C _{v23} =180 Ns/m	

Figure 1

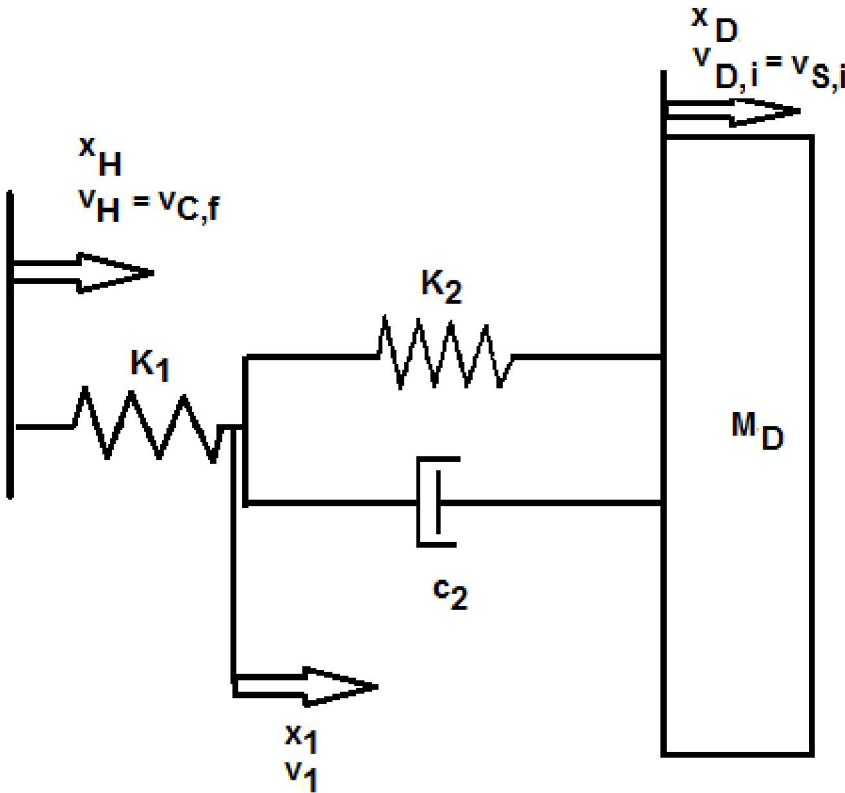

Figure 2

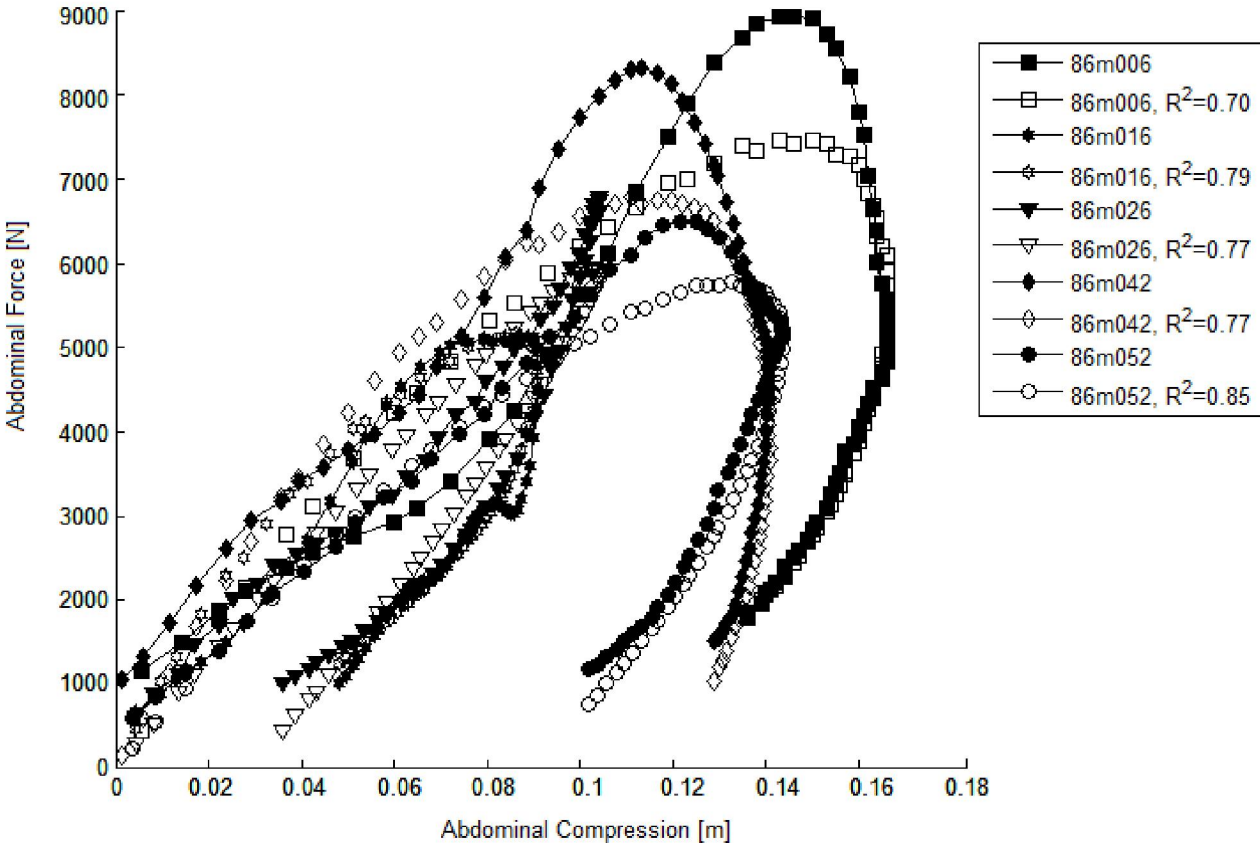

Figure 3

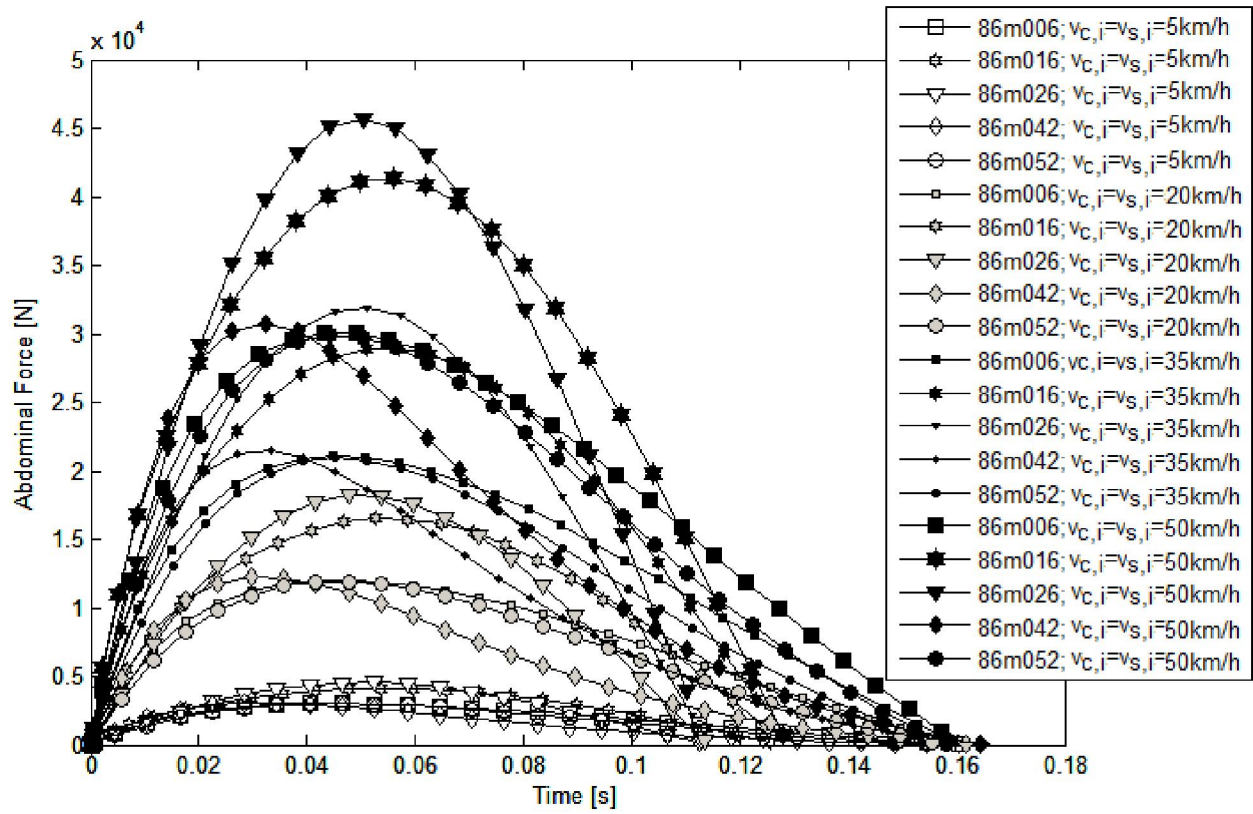

Figure 4

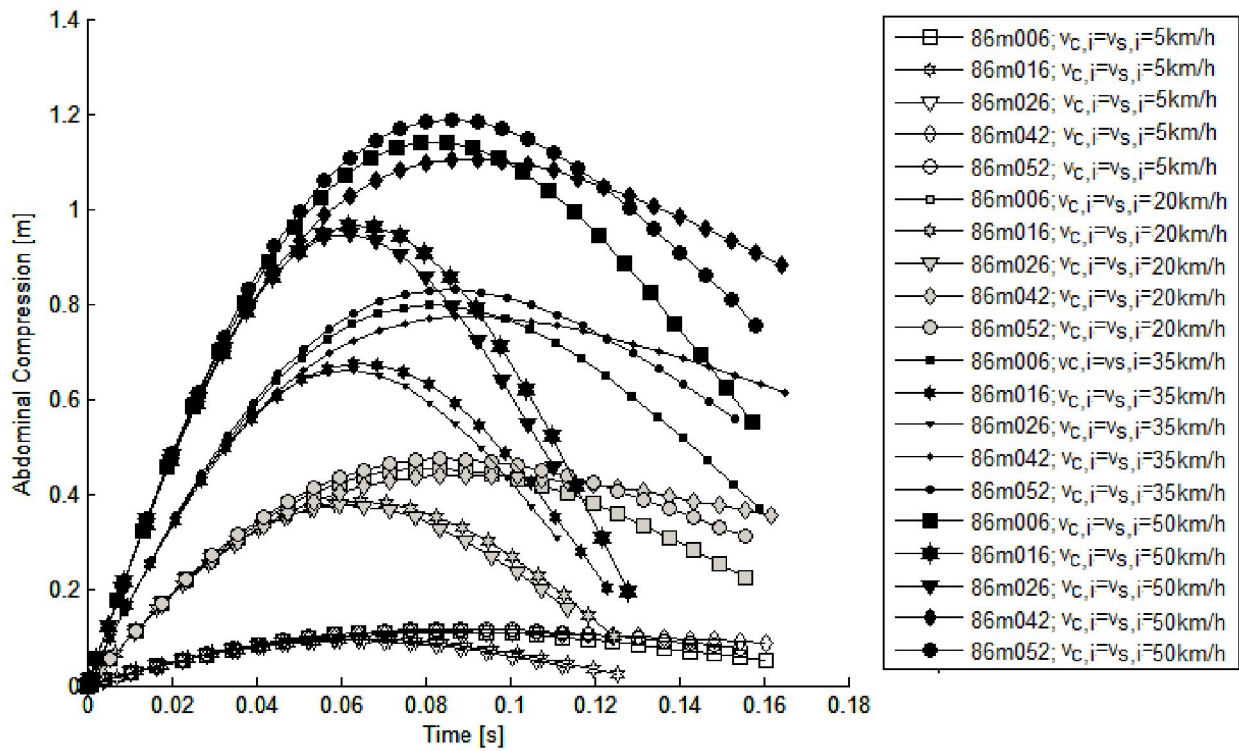

Figure 5

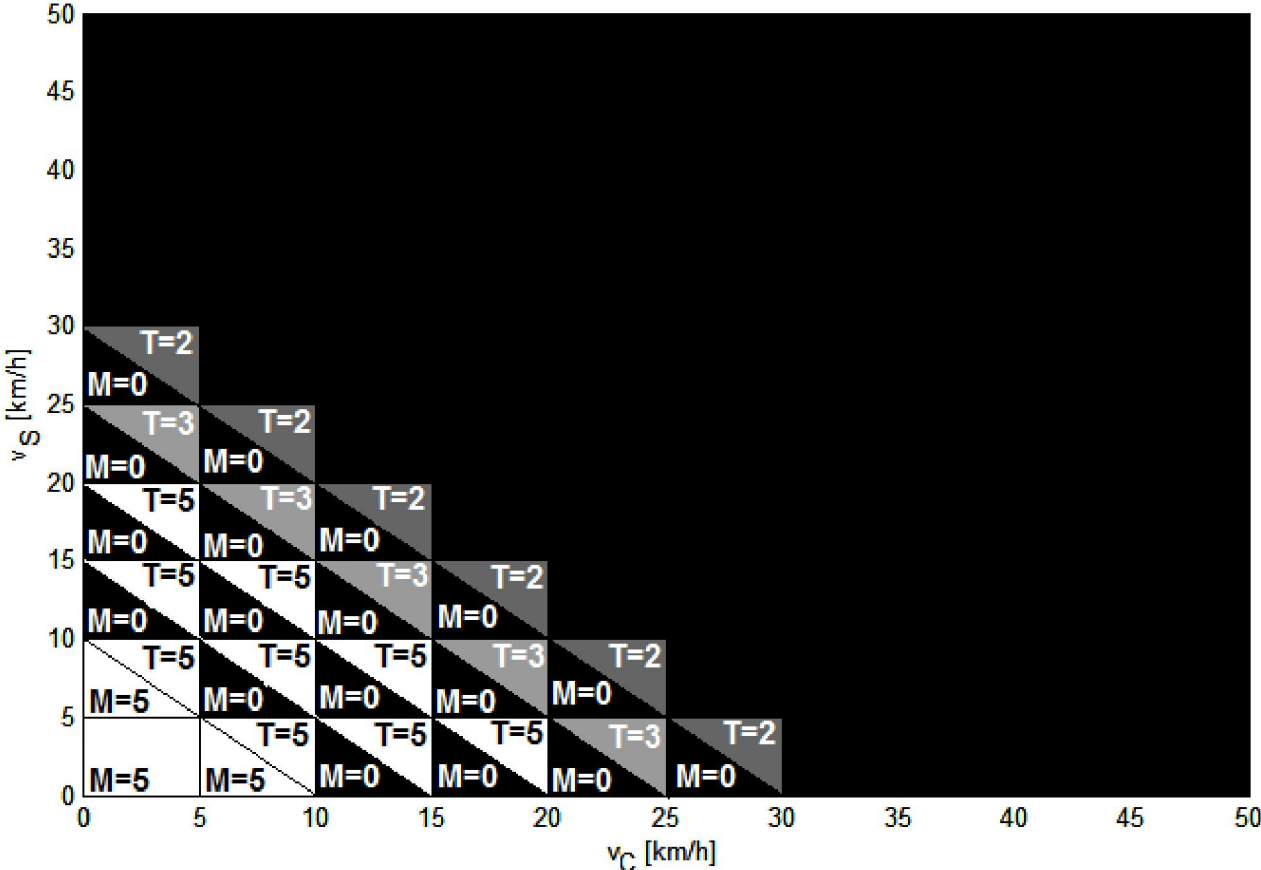

Figure 6

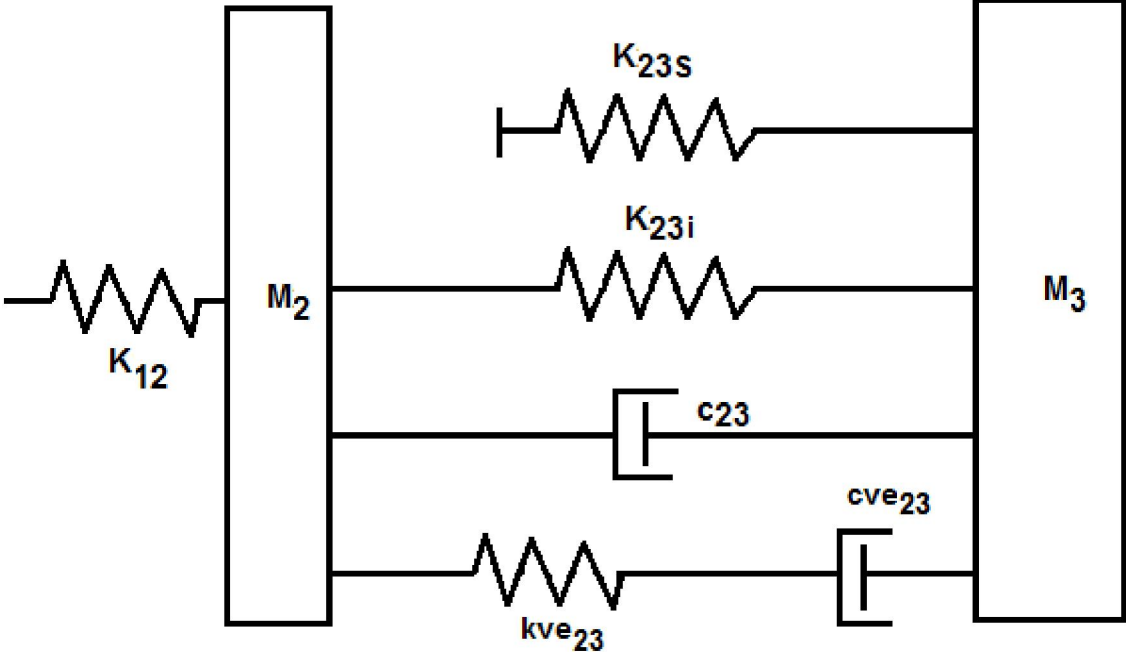

Figure 7

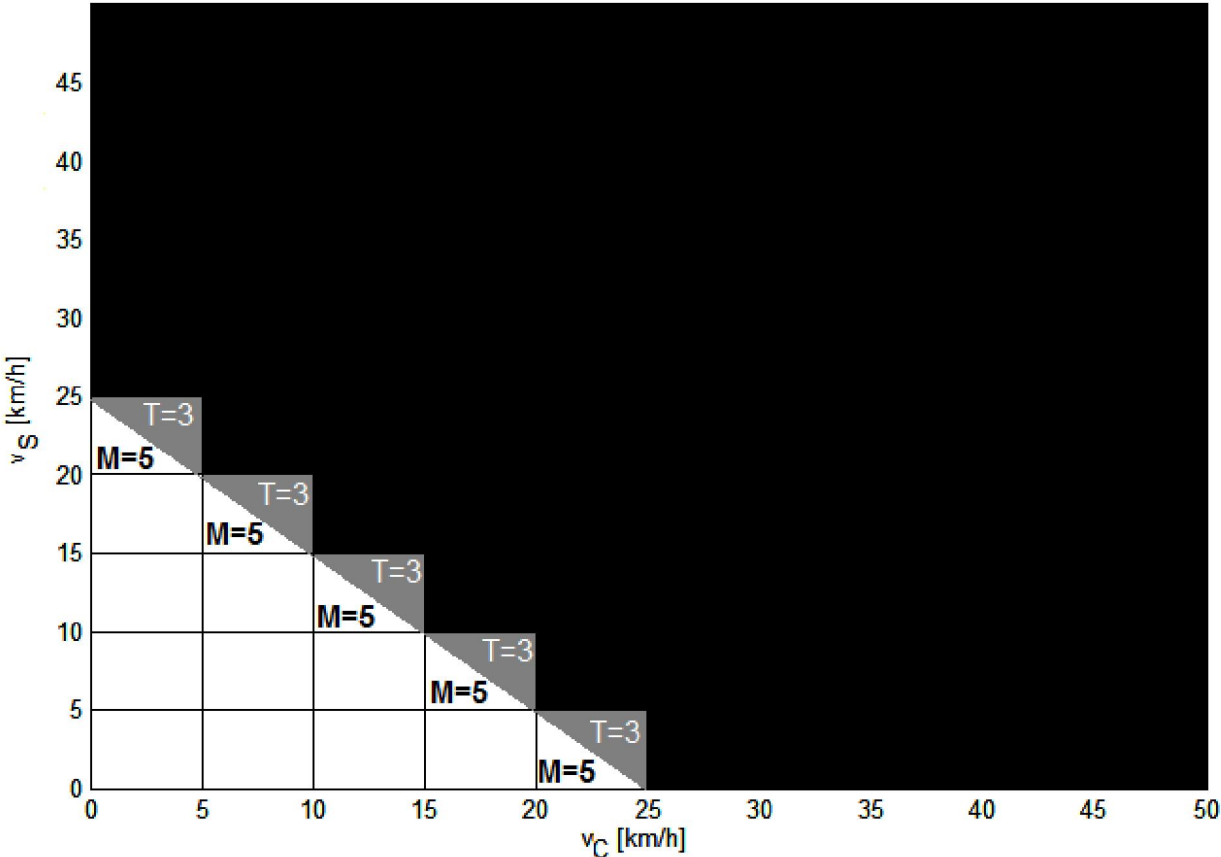

Figure captions

Figure 1 Dynamic model employed in this work: a spring (k_1) is put in series with the parallel of a spring (k_2) and a damper (c_2); the left constrain represents the handlebar (A) with its displacement and its speed (x_H , v_H , respectively), the right mass represents the driver (D) with its displacement and its speed (x_D , v_D); the handlebar is forced to move at a constant speed, equal to the final car speed $v_{C,f}$; as a consequence, the driver mass M oscillates around its equilibrium position, having an initial speed $v_{D,i}$ equal to the initial scooter speed $v_{S,i}$

Figure 2 Experimental results (filled markers) vs. model results (void markers) for tested cadavers

Figure 3, Abdominal force vs. time pattern for different car and scooter initial speed ($v_{C,i}$, $v_{S,i}$); each condition has been tested on all five cadavers;; the force rises quickly to its peak and then lowers with a smoother slope.

Figure 4, Abdominal compression vs. time pattern for different car and scooter initial speed ($v_{C,i}$, $v_{S,i}$); each condition has been tested on all five cadavers;; the initial tangent is horizontal, after the curve changes its convexity and it reaches its peak value.

Figure 5 Safety areas, as calculated with the 'maximum force' criterion. Each square represents a car speed/scooter speed couple. Each square is made of two triangles; the lower triangle reports the number of cadaver responses which would stay below AIS 3+ limit, according to Miller, 1989. The upper triangle reports the number of cadaver responses which would stay below AIS 2, according to Troiseuille et al., 2002. Black squares represent speed combinations which would produce injuries for all cadaver responses, according to both criteria

Figure 6 Lobdell's model; The impacting mass is m_1 , and skin compliance is represented by k_{12} . An energy-absorbing Chest structure is represented by a parallel Voigt and Maxwell spring-dashpot system that couples the sternal m_2 and spinal m_3 masses.

Figure 7 Safety areas, as calculated with the 'VC' criterion. Each square represents a car speed/scooter speed couple. Each square is made of two triangles; the lower triangle reports the number of cadaver responses which would stay below AIS 3+ limit, according to Miller, 1989. The upper triangle reports the number of cadaver responses which would stay below AIS 2, according to Troiseuille et al., 2002. Black squares represent speed combinations which would produce injuries for all cadaver responses, according to both criteria; white squares represent speed combinations which would not produce any injury for all cadaver responses, according to both criteria.

